

PW4001

POWER ANALYZER

4-channel compact power analyzer featuring:

- DC & 50/60 Hz power accuracy $\pm 0.03\%$ of reading $\pm 0.01\%$ of range
- Wide operating temperature range from -20°C to $+50^{\circ}\text{C}$ (-4°F to 122°F)
- Lightweight at 4.6 kg (162.26 oz.)
- 600 kHz measurement frequency band
- 2.5 MHz, 16-bit sampling performance
- 15 GB internal memory
- CAN input/output functionality
- AC power supply input from 100 to 240 V
- DC power supply input from 10.8 to 28 V **

**1 option



Features

- Easy power measurement with clamp current sensors
- 4 voltage channels and 4 current channels
- Accuracy of DC and 50/60 Hz that meets WLTP and SAE J1634 requirements
- Excellent environmental durability suitable for low-temperature testing of EVs and batteries (e.g., -10°C , -20°C , respectively)
- Weight: 4.6 kg(162.26 oz.), small and light enough to be held with one hand
- 15 GB internal memory for storing setting files, measured data, and screenshots
- Measured data can be converted to CAN format and output, enabling easy data integration with CAN analysis software (CAN output function)
- CAN data and measured data can be saved simultaneously (CAN input function)
- CAN data can be acquired via vehicle diagnostic communication using OBD-II/OBDOnUDS (CAN input function)
- Data can be saved at intervals as fast as 1 ms
- Simultaneous parallel calculation of all parameters such as RMS, harmonics, instantaneous waveforms, and efficiency

Applications

- Type approval testing to measure EV range (km), energy consumption (Wh/km), and fuel consumption (l/km)
- EV's real drive testing
- Efficiency measurement on inverter/motor test bench
- Evaluation of transient power and torque response of motors
- Recharge/discharge energy measurement of ESSs (Energy Storage Systems)
- Efficiency measurement on DC-DC converter, AC-DC converter
- Input/output power measurement and efficiency evaluation of high-voltage power conditioners

PW4001

POWER ANALYZER

Parts Names and Functions

Front

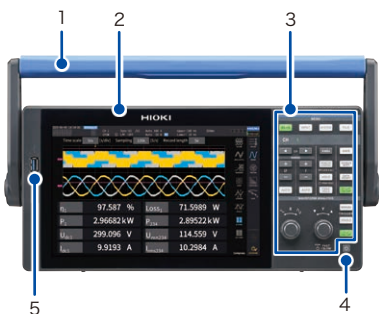

Rear side

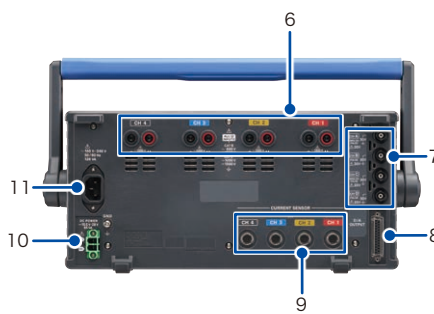

Left side

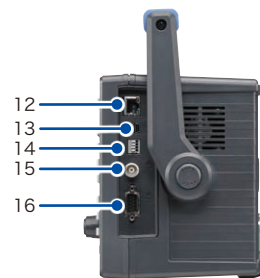

- | | | | |
|-----------------------|---|---|---|
| 1 Handle | 5 USB port | 9 Current input terminals | 13 USB port (mini-B type) |
| 2 Display area | 6 Voltage input terminals | 10 DC power supply (option: operates on 10.5 V to 28 V DC) | 14 External control terminal |
| 3 Control area | 7 Motor analysis (option) | 11 Power supply inlet | 15 BNC synchronization connector |
| 4 Power key | 8 Waveform and D/A output (option) | 12 RJ-45 connector | 16 CAN/CAN FD connector |

Software

GENNECT Space

(free download software)

- Logging
- Remote control
- Sync. Video and Map



Operating environment Windows 11, Windows 10 (64-bit edition, 21H2 or later)

GENNECT One

(free download software)

- Logging
- Dashboard
- Remote control
- File acquisition
- Automatic data collection



Operating environment Windows 11, Windows 10 (32-bit or 64-bit edition)

Measurement System Construction

LabVIEW Drivers and MATLAB Toolkit

Simple GUI operation on LabVIEW and the use of MATLAB functions allow you to quickly build your measurement system.

(LabVIEW is a trademark of NATIONAL INSTRUMENTS CORP., MATLAB is a trademark of MathWorks, Inc.)



PW Data Receiver

(free download software)

- Measured data saving
- Waveform data saving
- Remote control
- File acquisition



Operating environment Windows 11(64-bit edition), Windows 10 (64-bit edition, 21H2 or later)

CAN Editor(for PW)

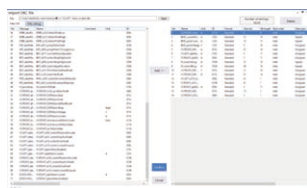

(free download software)

- Setting up CAN input/output function
- CAN IDs can be set from CAN definition file (DBC file)



Operating environment Windows 11(64-bit edition), Windows 10 (32-bit or 64-bit edition)

Basic Specifications

Model		PW4001	PW3390
Appearance			
Measurement parameters	Measurement frequency band	DC, 0.1 Hz to 600 kHz	DC, 0.5 Hz to 200 kHz
	Basic accuracy for 50/60 Hz power	± (0.03% of reading + 0.01% of range)	± (0.04% of reading + 0.05% of range)
	Accuracy for DC power	± (0.03% of reading + 0.01% of range)	± (0.05% of reading + 0.07% of range)
	Accuracy for 10 kHz power	± (0.2% of reading + 0.05% of range)	± (0.2% of reading + 0.1% of range)
	Accuracy for 50 kHz power	± (0.4% of reading + 0.1% of range)	± (0.4% of reading + 0.3% of range)
	Number of power measurement channels	4 channels	4 channels
	Voltage, current ADC sampling	16-bit, 2.5 MHz	16-bit, 500 kHz
	Voltage range	6 V, 15 V, 30 V, 60 V, 150 V, 300 V, 600 V, 1500 V	15 V, 30 V, 60 V, 150 V, 300 V, 600 V, 1500 V
	Current range	40 mA to 8000 A (6 ranges, based on sensor)	40 mA to 8000 A (6 ranges, based on sensor)
	Common-mode voltage rejection ratio	50 Hz/60 Hz: 80 dB or greater	50/60 Hz: 80 dB or greater
	Temperature coefficient	0.005%/°C	0.01%/°C
	Voltage input method	Isolated input, resistor voltage division	Isolated input, resistor voltage division
	Current input method	Isolated input from current sensor	Isolated input from current sensor
	External current sensor input	Yes (ME15W)	Yes (ME15W)
	Power supplied to external current sensor	Yes	Yes
Data update rate	1 ms, 10 ms, 50 ms, 200 ms	50 ms	
Voltage input	Maximum input voltage	AC 1000 V, DC 1500 V, ± 2000 V peak	1500 V, ± 2000 V peak
	Maximum rated line-to-ground voltage	AC 600 V/DC 1000 V CAT III AC 1000 V/DC 1500 V CAT II	600 V CAT III 1000 V CAT II
Analysis	Number of motor analysis channels	Maximum 2 motors *1	1 motor*1
	Motor analysis input format	Analog DC, frequency, pulse	Analog DC, frequency, pulse
Function	Current sensor phase shift calculation	Yes (Auto)	Yes
	Harmonics measurement	Yes (4 for each channel)	Yes
	Maximum harmonics analysis order	500th	100th
	Harmonics synchronization frequency range	0.1 Hz to 600 kHz	0.5 Hz to 5 kHz
	IEC Harmonic measurement	IEC6100-4-7:2002 compliant*1	-
	Flicker measurement	IEC6100-4-15:2010 compliant*1	-
	User-defined calculations	Yes	-
	Delta conversion	Yes (Δ-Y, Y-Δ)	Yes (Δ-Y)
D/A output	Yes*1 16ch (waveform output, analog output)	Yes*1 16ch (waveform output, analog output)	
Display	Display	10.1" WXGA TFT color LCD	9" WVGA TFT color LCD
	Touch screen	Yes	-
Interface	External storage media	USB 3.0	USB 2.0, CF card
	LAN (100BASE-TX, 1000BASE-T)	Yes	Yes (10BASE-T and 100BASE-TX only)
	RS-232C	-	Yes (maximum 38,400 bps)
	External control	Yes	Yes
	Synchronization of multiple instruments	Yes (up to 8 instruments)	Yes (up to 8 instruments)
	CAN or CAN FD	Yes	-
Dimensions, weight (W × H × D)	361 mm (14.21 in.) × 176 mm (6.93 in.) × 135 mm (5.31 in.), 4.6 kg (162.26 oz.)	340 mm (13.39 in.) × 170 mm (6.69 in.) × 156 mm (6.14 in.), 4.6 kg (162.26 oz.)	
Internal Memory	15 GB	-	

*1: Sold separately

Basic Specifications

Input specifications

(1) Voltage, current, and power measurement shared specifications	
No. of PW4001 input channels	Voltage 4 channels (U1 to U4) Current 4 channels (I1 to I4)
Measurement lines	Single-phase 2-wire (1P2W) Single-phase 3-wire (1P3W) 3-phase 3-wire (3P3W2M, 3V3A, 3P3W3M) 3-phase 4-wire (3P4W)
Measurement method	Voltage/current simultaneous digital sampling with zero-crossing synchronized calculation
Sampling	2.5 MHz, 16-bit
Measurement frequency band	DC, 0.1 Hz to 600 kHz
Frequency flatness	± 0.1% amplitude band: 50 kHz (typical) ± 0.1° phase band: 100 kHz (typical)
Effective measurement range	Voltage, current, and active power For DC: 0% to 110% of the range For AC: 1% to 110% of the range
Measurement modes	Wideband measurement mode
Data update rate	1ms, 10 ms, 50 ms, 200 ms Average and user-defined operations are unavailable when the data update interval is set to 1 ms.
LPF	Cutoff frequency f_c 500 Hz, 1 kHz, 5 kHz, 10 kHz, 50 kHz, 100 kHz, OFF Add ± 0.05% of the reading to the accuracy except if the LPF is set to off. The accuracy specifications are specified for frequencies less than or equal to one tenth the set cutoff frequency. The peak value is based on the LPF-processed values, whereas the peak-over judgment uses not-digital-LPF processed values.
Synchronization source	U1 to U4, I1 to I4, DC (fixed at the data update interval for DC only) PW4001-03, PW4001-05 only Ext1 to 2, Zph1, CH B, D Can be selected for each wiring configuration. (U and I of the same channel are measured in sync with the same synchronization source.) The zero-crossing point of the waveform after passing through the zero-cross filter is used as the reference when U or I is selected.
Synchronization source effective frequency range	DC, 0.1 Hz to 200 kHz
Synchronization source effective input range	1% to 110% of range
Zero-cross filter	Used in zero-crossing detection for voltage and current waveforms. Does not affect measured waveforms. Consists of a digital LPF and HPF filters. Cutoff frequencies are automatically determined based on the settings of the measurement upper and lower frequency limits as well as measurement frequencies. HPF is selectable between on and off.
Lower measurement frequency limit	Choose from the following frequency values for each wiring configuration: 0.1 Hz, 1 Hz, 10 Hz, 100 Hz, 1 kHz, 10 kHz, 100 kHz
Upper measurement frequency limit	Choose from the following frequency values for each wiring configuration: 100 Hz, 500 Hz, 1 kHz, 5 kHz, 10 kHz, 50 kHz, 100 kHz, 500 kHz, 1 MHz
Polarity detection	Voltage/current zero-crossing timing comparison method
Measurement parameters	Voltage (U), current (I), active power (P), apparent power (S), reactive power (Q), power factor (λ), phase angle (ϕ), voltage frequency (fU), current frequency (fI), efficiency (η), loss (Loss), voltage ripple factor (Urf), current ripple factor (Irf), current integration (Ih), power integration (WP), voltage peak (Upk), current peak (Ipk)
(2) Voltage measurement specifications	
Input terminal profile	Plug-in terminal (safety terminal)
Input method	Isolated input, resistance voltage division
Display range	RMS, DC: 0% to 150% of range (1500 V range: 0% to 135%) Waveform peak: 0% to 300% of range (1500 V range: 0% to 135%)
Range	6 V, 15 V, 30 V, 60 V, 150 V, 300 V, 600 V, 1500 V
Crest factor	3 relative to voltage range rating (however, 1.35 for 1500 V range)
Input resistance, input capacitance	3 M Ω ± 30 k Ω , 1 pF typical
Maximum input voltage	1000 V AC, 1500 V DC or ± 2000 V peak
Maximum rated line-to-ground voltage	600 V AC, 1000 V DC in measurement category III Anticipated transient overvoltage: 8000 V 1000 V AC, 1500 V DC in measurement category II Anticipated transient overvoltage: 8000 V

(3) Current measurement specifications

Input terminal profile	Dedicated connector (ME15W)	
Input method	Current sensor input method	
Display range	RMS, DC: 0% to 150% of range Waveform peak: 0% to 300% of range	
Range	Probe1: Automatically recognizes the sensor's rated current	2 A sensor : 40 mA, 80 mA, 200 mA, 400 mA, 800 mA, 2 A
		20 A sensor : 400 mA, 800 mA, 2 A, 4 A, 8 A, 20 A
		200 A sensor : 4 A, 8 A, 20 A, 40 A, 80 A, 200 A
		2000 A sensor : 40 A, 80 A, 200 A, 400 A, 800 A, 2 kA
		5 A sensor : 100 mA, 200 mA, 500 mA, 1 A, 2 A, 5 A
		50 A sensor : 1 A, 2 A, 5 A, 10 A, 20 A, 50 A
		500 A sensor : 10 A, 20 A, 50 A, 100 A, 200 A, 500 A
		5000 A sensor : 100 A, 200 A, 500 A, 1 kA, 2 kA, 5 kA
		1000 A sensor : 20 A, 40 A, 100 A, 200 A, 400 A, 1 kA
		Selectable for each wiring (Only when the same sensors are used for all channels of the same wiring configuration)
	CT9920: The sensor output rate can be selected	1 V/A : 40 mA, 80 mA, 200 mA, 400 mA, 800 mA, 2 A
		100 mV/A : 400 mA, 800 mA, 2 A, 4 A, 8 A, 20 A
		10 mV/A : 4 A, 8 A, 20 A, 40 A, 80 A, 200 A
		1 mV/A : 40 A, 80 A, 200 A, 400 A, 800 A, 2 kA
		0.1 m A : 400 A, 800 A, 2 k A, 4 kA, 8 kA, 20 kA
		Selectable for each wiring (Only when the same sensors are used for all channels of the same wiring configuration)
Crest factor	3 relative to current range rating	
Input resistance	1 M Ω ± 50 k Ω	
Maximum input voltage	8 V, ± 12 V peak (10 ms or less)	
Maximum number of connected channels	Up to 4 Up to three CT6877A, CT6876A, or CT6904A series current sensors can be connected when using an AC or DC power supply (power supply voltage: 10.5 V to 20 V) and with an operating temperature of 40° C to 50° C. Up to three CT6877A, CT6876A, or CT6904A series current sensors can be connected when using a DC power supply (power supply voltage: 20 V to 28 V) and with an operating temperature of 30° C to 40° C.	

(4) Frequency measurement

Number of measurement channels	4 channels (fU1 to fU4, fI1 to fI4)
Measurement method	Reciprocal method The waveforms processed with the zero-cross filter are measured.
Measurement range	0.1 Hz to 500 kHz (The display shows 0.00000 Hz or ----- Hz if measurement was not possible.) The range is limited by the measurement lower frequency limit setting.
Measurement accuracy	± 0.005 Hz Assuming all the following conditions are met: • Measurement parameter: voltage/frequency • Data update interval: 50 ms or more • Voltage range: 15 V range or higher • Inputted waveform: a sine wave with a magnitude of at least 50% of the range • Frequency range: 45 Hz to 66 Hz Under conditions other than listed above: ± 0.05% of the reading (With a sine wave at least 30% of the measurement range of the measurement source. However, add ± 0.05 % of the reading for the data update interval of 1 ms.)
Display resolution	0.10000 Hz to 9.99999 Hz, 9.9000 Hz to 99.9999 Hz, 99.000 Hz to 999.999 Hz, 0.99000 kHz to 9.99999 kHz, 9.9000 kHz to 99.9999 kHz, 99.000 kHz to 999.999 kHz

(5) Integration measurement

Measurement modes	Can be chosen between RMS and DC for each wiring. (The DC mode is selectable for the 1P2W wiring configuration only.)
Measurement parameters	Current integration (Ih+, Ih-, Ih), Active power integration (WP+, WP-, WP) The instrument measures Ih+ and Ih- only in DC mode; Ih only in RMS mode.
Measurement method	Digital calculation based on current and active power. (Calculations are performed using not-averaged values during averaging.) In DC mode: Integrates current values and instantaneous power values for each polarity at every sampling point. In RMS mode: Integrates current RMS values and active power values at the measurement intervals.
Measurement interval	Same as the data update interval
Display resolution	999999 (6 digits + decimal point), Starts from the resolution assuming 1% of each range to be 100% of the range.
Measurement range	0 Ah / Wh to ± 99.9999 PAh / PWh
Integration time	0 s to 9999 h 59 min. 59 s Integration stops if the integration time exceeds the range.
Integration time accuracy	± 0.02% of reading (-20°C to 50°C) (-4° F to 122° F)
Integration accuracy	± (Current or active power) ± (Integration time accuracy)
Integration control	All-channel synchronized integration: Manual control, Real time control, Timer control Connection-specific independent integration: Manual control, Real time control, Timer control • No data will be saved.

PW4001

(6) Harmonics measurement

Number of measurement channels	Up to 4
Synchronization source	Based on the synchronization source setting of the voltage, current, and power measurement selected for each wiring configuration.
Measurement modes	Wideband measurement mode
Measurement parameters	Harmonic voltage RMS value, harmonic voltage content percentage, harmonic voltage phase angle, harmonic current RMS value, harmonic current content percentage, harmonic current phase angle, harmonic active power, harmonic power content percentage, harmonic voltage-vs.-current phase difference, total harmonic voltage distortion, total harmonic current distortion, voltage unbalance rate, current unbalance rate
FFT processing word length	32-bit
Antialiasing	Digital filter (automatically set based on synchronization frequency)
Window function	Rectangular
Grouping	OFF, Type 1 (harmonic sub-group), Type 2 (harmonic group) (Setting common to all channels)
THD calculation method	THD_F, THD_R Select the calculation order from between 2nd and 500th. (However, limited to the maximum analysis order of each mode.) (Setting common to all channels)

(7) Wideband measurement mode: wideband harmonic measurement

Measurement method	Zero-crossing sync calculation method (the same window for each synchronization source), with gaps Fixed sampling interpolation calculation method		
Synchronization frequency range	0.1 Hz to 600 kHz		
Data update rate	Fixed at 50 ms. When it is set to 10 ms, only harmonic data is updated at 50 ms intervals. When it is set to 200 ms, values are obtained by averaging four sets of 50 ms data.		
Maximum analysis order and Window wave number	Fundamental wave frequency	Window wave number	Maximum analysis order
	$0.1 \text{ Hz} \leq f \leq 2 \text{ kHz}$	1	500th
	$2 \text{ kHz} < f \leq 5 \text{ kHz}$	1	300th
	$5 \text{ kHz} < f \leq 10 \text{ kHz}$	2	150th
	$10 \text{ kHz} < f \leq 20 \text{ kHz}$	4	75th
	$20 \text{ kHz} < f \leq 50 \text{ kHz}$	8	30th
	$50 \text{ kHz} < f \leq 100 \text{ kHz}$	16	15th
	$100 \text{ kHz} < f \leq 200 \text{ kHz}$	32	7th
	$200 \text{ kHz} < f \leq 300 \text{ kHz}$	64	5th
$300 \text{ kHz} < f \leq 500 \text{ kHz}$	128	3th	
$500 \text{ kHz} < f \leq 600 \text{ kHz}$	256	1th	
Phase zero-adjustment	Phase zero-adjustment can be started by using keys or communications commands. (Only available when the synchronization source is set to Ext) Phase zero-adjustment values can be set automatically or manually. Valid setting range of the phase zero-adjustment: 0.000° to $\pm 180.000^\circ$ (in 0.001° increments)		
No. of FFT points	Automatically selected from among 2048, 4096, and 8192 points.		
Measurement accuracy	Add the following values to the voltage, current, power, and phase difference accuracy. When the fundamental frequency is 100 Hz or more, add another $\pm 0.1\%$ of the range to the following voltage, current, and power accuracies, and add $\pm 0.1^\circ$ to the phase difference accuracy. When the fundamental frequency is 2 kHz or more, add another $\pm 0.05\%$ of the reading and $\pm 0.1\%$ of the range to the following voltage, current, and power accuracies, and add $\pm 0.1^\circ$ to the phase difference accuracy.		
	Frequency	Voltage, current, power \pm (% of reading)	Phase difference \pm ($^\circ$)
	DC	0.05%	-
	$0.1 \text{ Hz} \leq f \leq 100 \text{ Hz}$	0.01%	0.1°
	$100 \text{ Hz} < f \leq 1 \text{ kHz}$	0.03%	0.1°
	$1 \text{ kHz} < f \leq 10 \text{ kHz}$	0.08%	0.6°
	$10 \text{ kHz} < f \leq 50 \text{ kHz}$	0.15%	$(0.020 \times f) \pm 0.5^\circ$
	$50 \text{ kHz} < f \leq 200 \text{ kHz}$	0.20%	$(0.030 \times f) \pm 2.0^\circ$
<ul style="list-style-type: none"> In the expressions listed above, the unit of frequency (f) is kilohertz (kHz). The figures for voltage, current, power, and phase difference for frequencies over 200 kHz are values for reference purposes. When the fundamental wave has a frequency within the range of 16 Hz to 850 Hz, the figures for voltage, current, power, and phase difference over 6 kHz are values for reference purposes. When the fundamental wave has a frequency outside the range of 16 Hz to 850 Hz, the figures for voltage, current, power, and phase difference for frequencies other than the fundamental wave are values for reference purposes. Accuracy values for phase difference are specified for input with the voltage and current of the same order that have an amplitude of at least 10% of the range. 			

(8) IEC measurement mode: IEC standard harmonic measurement

Measurement method	Compliant with IEC61000-4-7:2002, without gaps or overlaps
Measurement frequency setting	50 Hz / 60 Hz
Synchronization frequency range	When set to 50 Hz: 45 Hz to 55 Hz When set to 60 Hz: 45 Hz to 66 Hz
Data update rate	Approx. 200 ms (50 Hz: 10 waves; 60 Hz: 12 waves)
Analysis orders	Harmonics: 0th to 200th order Intermediate harmonics: 0.5th to 200.5th order
Window wave number	10 waves for 50 Hz measurement-frequency setting; 12 waves for 60 Hz
FFT Number of points	8192 points
Measurement accuracy	Add $\pm 0.04\%$ of the range to each of the basic accuracies for the module in use (voltage, current, power, and phase). For a frequency of 10 kHz or more, add another $\pm 0.04\%$ of the range.

(9) Flicker measurement (PW9006 license option)

Measurement channels	Up to 4
Measurement method	Compliant with IEC 61000-4-15 Ed 2.0 : 2010 flicker meter Class F1
Measured parameters	Short-term flicker (Pst), Short-term flicker maximum value (PstMax), Long-term flicker (Plt), Instantaneous flicker maximum value (PinstMax), Instantaneous flicker minimum value (PinstMin), Relative steady voltage change (dc), Maximum relative voltage change (dmax), Time for which the relative voltage change exceeded the threshold (Tmax)
Measurement frequency	50/60 Hz (measurable in IEC measurement mode only)
Measurement range	Pst, Plt: 0.0001 P.U. to 6400 P.U. (logarithmic 1400-way split)
Flicker filter	230 V lamp, 120 V lamp
Measurement accuracy	dc, dmax: $\pm 4\%$ (at a dmax of 4%) Pst: $\pm 5\%$ (Pst = 0.2 to 5)

PW4001

Measurement accuracy

Accuracy guarantee conditions	Accuracy guarantee duration: 12 months (The accuracy guarantee duration for voltage, current, and power measurements, as well as for voltage accuracy of the motor analysis option, is either 6 months or 12 months. Accuracy is calculated by multiplying the reading error specified in each accuracy specification by 1.5.) Accuracy guarantee temperature and humidity range: 23° C ± 3° C (73° F ± 5° F), 80% RH or less Warm-up time: 30 minutes or longer Other conditions: Within the effective measurement ranges, sine waveforms or DC input, a line-to-earth voltage of 0 V After zero adjustment has been performed and a change in ambient temperature does not exceed ± 1° C after zero adjustment.
-------------------------------	--

Voltage (U) and Current (I)

Accuracy	± (% of reading + % of range)
DC	0.03% + 0.01%
0.1 Hz ≤ f ≤ 30 Hz	0.10% + 0.20%
30 Hz < f ≤ 45 Hz	0.10% + 0.10%
45 Hz < f ≤ 440 kHz	0.03% + 0.01%
440 Hz < f ≤ 1 kHz	0.05% + 0.05%
1 kHz < f ≤ 10 kHz	0.20% + 0.05%
10 kHz < f ≤ 50 kHz	0.40% + 0.10%
50 kHz < f ≤ 100 kHz	0.01*f % + 0.20%
100 kHz < f ≤ 200 kHz	0.025*f % + 0.30%
Frequency Band	600 kHz (-3 dB typical)

Active power (P) and Power phase angle (φ)

Accuracy	Active power (P)	Power phase angle (φ)
	± (% of reading + % of range)	°
DC	0.03% + 0.01%	—
0.1 Hz ≤ f ≤ 30 Hz	0.10% + 0.20%	± 0.05°
30 Hz < f ≤ 45 Hz	0.10% + 0.10%	± 0.05°
45 Hz < f ≤ 440 kHz	0.03% + 0.01%	± 0.05°
440 Hz < f ≤ 1 kHz	0.05% + 0.05%	± 0.05°
1 kHz < f ≤ 10 kHz	0.20% + 0.05%	± 0.20°
10 kHz < f ≤ 50 kHz	0.40% + 0.10%	± (0.02*f)°
50 kHz < f ≤ 100 kHz	0.01*f % + 0.20%	± (0.02*f)°
100 kHz < f ≤ 200 kHz	0.025*f % + 0.30%	± (0.02*f)°

- Unit for "f" in accuracy calculations as mentioned in the table above: kHz
- Voltage and current DC values are defined for U_{dc} and I_{dc}, while frequencies other than DC are defined for U_{rms} and I_{rms}.
- When U or I is selected as the synchronization source, accuracy is defined for source input of at least 5% of range.
- Power phase angle accuracy is defined at a power factor of zero with 100% input.
- Add the current sensor accuracy to the above accuracy figures for current, active power, and phase difference.
- The accuracy figures for voltage, current, active power, and phase difference for 0.1 Hz ≤ f < 10 Hz are reference values.
- The accuracy figures for voltage, active power, and phase difference in excess of 220 V from 10 Hz ≤ f < 16 Hz are reference values.
- The accuracy figures for voltage, active power, and phase difference in excess of 1000 V from 16 Hz ≤ f < 30 kHz are reference values.
- The accuracy figures for voltage, active power, and phase difference in excess of 750 V from 30 kHz < f ≤ 100 kHz are reference values.
- The accuracy figures for voltage, active power, and phase difference in excess of (22000/f [kHz]) V from 100 kHz < f ≤ 1 MHz are reference values.
- For the voltage 6 V range, add ± 0.02% of range to voltage and active power accuracy.
- For the voltage 15 V range, add ± 0.005% of range to voltage and active power accuracy.
- When using probe 1 and the sensor's rated 1/25 and 1/50 range, add ± 0.02% of range to current and active power accuracy.
- When using probe 1 and the sensor's rated 1/10 range, add ± 0.01% of range to current and active power accuracy.
- The effective measurement range of the current sensor (9272-05, CT7642, CT7742, CT7044, CT7045, CT7046) is between 0.5% of full scale and 100% of full scale.
- When measuring DC 1000 V or greater, add ± 0.05% of reading to voltage and active power accuracy.
- When 100% of range < input ≤ 110% of range, range error × 1.1.
- If a voltage is over 600 V, add the following values to the power phase angle accuracy:
0.1 Hz < f ≤ 500 Hz ± 0.1°, 500 Hz < f ≤ 5 kHz ± 0.3°, 5 kHz < f ≤ 20 kHz ± 0.5°, 20 kHz < f ≤ 200 kHz ± 1°
- Add the following value to the accuracy figures for voltage and active power if a voltage of 600 V or more is measured.
± (0.003 × V²)% of the reading ± (1 × V²) mV (V is input voltage [kV])
- Even when the voltage input value decreases, the effect of self-heating persists until the input resistance temperature drops.
If the input voltage is over 900 V, other measurement channels (up to 600 V) will also have half the influence.
- If zero adjustment is performed with a warm-up time of less than 60 minutes, add ± 0.02% of the range to the voltage, current, and active power accuracy.
- When the data update interval is 1 ms, add ± 0.1% of the range to the voltage, current, and active power accuracy.

Apparent power (S) Measurement accuracy	(voltage accuracy) + (current accuracy) ± 10 digits
Reactive power (Q) Measurement accuracy	For any condition except if φ = 0° or ± 180° (Apparent power accuracy) ± [1 - sin[φ + (Power phase angle accuracy)]] / sin φ × (100% of the reading) ± [√(1.001 - λ ²) - √(1 - λ ²)] × (100% of the range) For φ = 0° and ± 180° (Apparent power accuracy) ± [sin(Power phase angle accuracy)] × (100% of the range) ± (3.16% of the range) The symbol λ designates the display value of the power factor.
Power factor (λ) Measurement accuracy	For any condition except if φ = ± 90° ± [1 - cos[φ + (Power phase angle accuracy)]] / cos φ × (100% of the reading) ± 50 digits For φ = ± 90° ± cos[φ + (Power phase angle accuracy)] × (100% of the range) ± 50 digits The symbol φ designates the display value of the power phase angle. Both of the above are specified at voltage/current range rating input.
Waveform peak measurement accuracy	Voltage and current RMS value accuracy ± 1% of the range (300% of the range is applied as a peak range)
Effects of temperature	Add ± 0.005% of the reading/° C to the voltage, current, and active power accuracy within the range of -20° C to 20° C or 26° C to 50° C. Add ± 0.005% of the range/° C to DC accuracy of the voltage, current, and active power if a change in operating temperature range reaches or exceeds ± 1° C after zero adjustment. For the 6 V range, add another ± 0.005% of the reading/° C to the DC accuracy of the voltage, current and active power.

PW4001

Common-mode rejection ratio (effects of commonmodevoltage)	50 Hz/60 Hz: 80 dB or more Specified for CMRR when the maximum input voltage is applied between the voltage input terminals and the enclosure for all measurement ranges.
Effects of external magnetic fields	± 1% of the range or less (in a magnetic field of 400 A/m, DC or 50 Hz/60 Hz)
Effects of power factor on active power	For any condition except if $\phi = \pm 90^\circ$ $\pm \{1 - \cos[\phi + (\text{Phase accuracy})] / \cos \phi\} \times (100\% \text{ of the reading})$ For $\phi = \pm 90^\circ$ $\pm \cos[\phi + (\text{Phase accuracy})] \times (100\% \text{ of VA})$
Effect of conducted radio frequency electromagnetic field	For current and active power measurement, 6% of full scale or less at 10 V Current full scale means the sensor's rated current Active power full scale means the voltage range \times current sensor rating
Effect of radiated radio frequency electromagnetic field	For current and active power measurement, 6% of full scale or less at 10 V/m Current full scale means the current sensor rating Active power full scale means the voltage range \times current sensor rating

Waveform recording

Number of measurement channels	Voltage and current waveforms: Up to 4 channels (up to 8 waveforms can be displayed) Motor waveform: Up to 2 analog DC channels + up to 4 pulse channels
Recording capacity	(5 megawords) \times [(Number of measured items, including voltage and current) \times (Number of channels, up to 4) + (Number of motor waveforms)] No memory segmentation function
Waveform resolution	16-bit
Sampling speed	<ul style="list-style-type: none"> • Voltage and current waveform • Motor waveform (analog DC)* (1 MS/s is interpolated with 0th held when 2.5 MS/s of data is sampled.) <ul style="list-style-type: none"> • Motor waveform (pulse)* 2.5 MS/s, 1.0 MS/s, 500 kS/s, 250 kS/s, 100 kS/s, 50 kS/s, 25 kS/s, 10 kS/s
Recording length	1 kiloword, 5 kilowords, 10 kilowords, 50 kilowords, 100 kilowords, 500 kilowords, 1 megaword, 5 megawords
Storage mode	Peak-to-peak compression
Trigger mode	SINGLE / NORMAL(auto-trigger setting available)
Pre-trigger	0% to 100% of the recording length, in 10 percent increments
Trigger detection method	<ul style="list-style-type: none"> • Level trigger (detects triggers based on fluctuations in the level of storage waveforms) Trigger source: Voltage and current waveforms, voltage and current waveforms processed by the zero-cross filter, manual trigger, motor waveform, motor pulse Trigger slope: Rising edge, falling edge Trigger level: $\pm 300\%$ of the range for waveforms in 0.1 percent increments • Event trigger Triggers are detected based on fluctuations in the values of basic measurement items. The trigger-detecting conditions are determined based on the logical OR and AND of the following four events. The logical AND takes precedence over the logical OR. Events: Composed of basic measurement items, inequality signs (<, >), and numerical values (0 to $\pm 99999.9T$). Ev n:Item \square X.XXXXX y (n: 1 to 4, Item: basic measurement item, \square: inequality signs, X.XXXXX: six-digit constant, y: SI prefix)

*PW4001-03 and -05 models with motor analysis option only.

PW4001

Motor Analysis (Option)

(PW4001-03, -05 only)

(1) Analog DC, frequency, pulse input shared specifications

Number of input channels	4 channels		
	Channel	Input parameter	
	CH A, CH C	Analog DC, frequency, pulse	
	CH B, CH D	Frequency, pulse	
Operating mode	Motor analysis mode		
		Measurement or detection item (input type)	Maximum number of analysis parameters
	Pattern 1	Torque(Analog/Freq), Speed(Pulse)	2 motors
	Pattern 2	Torque(Analog/Freq), Speed(Pulse), Direction, Origin(Pulse)	1 motor
	Pattern 3	Torque(Analog/Freq), Speed(Pulse), Direction	1 motor
	Pattern 4	Torque(Analog/Freq), Speed(Pulse), Origin(Pulse)	1 motor
	Pattern 5	Torque(Analog/Freq), Speed(Analog)	1 motor
	Individual input mode Ch. A, Ch. C: DC voltage measurement, frequency measurement Ch. B, Ch. D: Frequency measurement		
Input terminal profile	Isolated BNC connector		
Input method	Function-isolated input and single-end input Between-channels function isolation		
Input resistance (DC)	1 M Ω ± 50 k Ω		
Maximum input voltage	20 V		
Maximum rated line-to-ground voltage	30 V (50 Hz / 60 Hz)		
Measurement parameters	Voltage, torque, RPM, frequency, slip, motor power		
Synchronization source	Same as described in “Voltage, current, and power measurement shared specifications” in the basic specifications		
Lower measurement frequency limit	Select from among the following frequency values for each motor synchronization source: 0.1 Hz, 1 Hz, 10 Hz, 100 Hz		
Upper measurement frequency limit	Select from among the following frequency values for each motor synchronization source: 100 Hz, 500 Hz, 1 kHz, 5 kHz, 10 kHz, 50 kHz, 100 kHz, 500 kHz, 1 MHz, 2 MHz		
Input frequency source	Selectable between fU1 to fU4 and fI1 to fI4. The frequency for slip calculation can be set.		
No. of motor poles	2 to 254		
Z-phase pulse detection reference	The reference for detecting Zph of the synchronization source can be set in operating mode 2 or 4. Rising edge, falling edge		

(2) Analog DC input (CH A, CH C)

Measurement range	1 V, 5 V, 10 V
Crest factor	1.5
Effective input range	1% to 110% of range
Sampling	1 MHz, 16-bit
LPF	1 kHz / OFF (20 kHz)
Response speed	0.2 ms (when the LPF is disabled)
Measurement method	Simultaneous digital sampling, zero-crossing synchronization calculation method (Between-zero-crossing averaging)
Measurement accuracy	± 0.03% of reading ± 0.03% of range
Effects of temperature	Add ± 0.005% of the reading/°C within the range of -20° C to 20° C or 26° C to 50° C. Also, add ± 0.005% of the range/°C for temperature changes of ± 1° C or more after zero adjustment.
Effects of commonmode voltage	± 0.01% of the range or less When a voltage of 30 V (DC, 50 Hz/60 Hz) is applied between the input terminals and the enclosure
Effects of external magnetic fields	± 0.1% of the range or less (in a magnetic field of 400 A/m, DC or 50 Hz/60 Hz)
Display range	0 to ± 150%
Scaling	For torque: ± 0.01 to 9999.99 For RPM: ± 0.00001 to 99999.9
Zero-adjustment	Scaled input offsets less than or equal to ± 10% of the range are compensated for to zero. When the torque meter correction is enabled, input offsets are compensated to zero after adding the calibration values.
Torque meter correction	OFF/ON (selectable by motor) • Nonlinearity correction Torque values are corrected using an 11-point (at a maximum) correction table of torque calibration points (N · m) vs. torque calibration values (N · m). • Friction correction Torque values are corrected using an 11-point (at a maximum) correction table of RPM values (r/min.) with consideration of rotation directions vs. torque calibration values (N · m). Each interval between torque calibration values are linearly interpolated. The unit for the correction table depends on the setting. Enter a 6-digit calibration value. The signs of torque calculation are used for detecting rotation directions: forward (plus sign) and backward (minus sign).
Torque calculations and correction	OFF : (Torque value) = S × [X - (Zero-correction value)] ON : (Torque value) = S × [X - (Zero-correction value)] - At - Bt S : Scaling X : Input signal-to-torque converted value At : Nonlinearity correction value Bt : Friction correction value

PW4001

(3) Frequency input (CH A, CH B, CH C, CH D)

Detection level	Low: approx. 0.8 V or less; High: approx. 2.0 V or more
Measurement frequency band	0.1 Hz to 2 MHz (when the duty ratio is set at 50%)
Minimum detection width	0.25 μs or more
Measurement range	The zero-point frequency f_c and frequency f_d at rated torque in $f_c \pm f_d$ (Hz) can be set. Set f_c and f_d using 7-digit figures in the range of 1 kHz to 500 kHz. However, values must be set so that both the inequalities $(f_c + f_d) \leq 500$ kHz and $(f_c - f_d) \geq 1$ kHz are met.
Measurement accuracy	$\pm 0.01\%$ of the reading When the data update interval is set to 1 ms, add $\pm 0.01\%$ of the reading to the measuring accuracy.
Display range	1.000 kHz to 500.000 kHz
Scaling	± 0.01 to 9999.99
Zero-adjustment	Offsets of input within the range of $f_c \pm 1$ kHz can be compensated to zero. When the torque meter correction is ON, calibration values are added to compensate for offsets to zero.
Units	mN · m, N · m, kN · m
Torque meter correction	Same as torque meter correction with analog DC input
Torque calculations and correction	Same as torque meter correction with analog DC input

(4) Pulse input (CH A, CH B, CH C, CH D)

Detection level	Low: approx. 0.8 V or less; High: approx. 2.0 V or more
Measurement frequency band	0.1 Hz to 2 MHz (when the duty ratio is set at 50%)
Minimum detection width	0.25 μs or more
Pulse filter	OFF / Weak / Strong positive/negative pulses of less than 0.25 μs are ignored with the Weak setting, as are those less than 5 μs with the Strong setting)
Measurement range	2 MHz
Measurement accuracy	$\pm 0.01\%$ of reading When the data update interval is set to 1 ms, add $\pm 0.01\%$ of the reading to the measuring accuracy.
Display range	0.1 Hz ~ 2.00000 MHz
Units	Hz, r / min
Frequency division setting range	± 1 to 60000
Rotation direction detection	Individually settable in [A-D] Pattern 2 to Pattern 5 of motor analysis mode Detects direction based on lead/lag of Ch. B and Ch. C in [A-D].
Mechanical angle origin detection	Individually settable in [A-D] Pattern 2 to Pattern 5 of motor analysis mode Ch. B frequency division is cleared at the Ch. D rising or falling edge in [A-D].

Waveform and D/A output (Option)

(PW4001-02, 05 only)

Number of output channels	16 channels
Output terminal profile	D-sub 25-pin connector × 1
Output details	Switchable between waveform output and analog output (selectable from basic measurement)
D/A conversion resolution	16-bit (polarity + 15 bits)
Output refresh rate	Waveform output: 1 MHz Analog output: 1 ms, 10 ms, 50 ms, 200 ms (depending on data update intervals of selected items, with an error of ± 1 ms)
Output voltage	Waveform output: Switchable between ± 2 V f.s. and ± 1 V f.s., crest factor: 2.5 or more The settings affect all channels. Analog output: ± 5 V DC f.s. (approx. up to ± 12 V DC)
Maximum output voltage	Approx. ± 12 V
Output resistance	100 Ω ± 5 Ω
Output accuracy	Waveform output: Add $\pm 0.5\%$ f.s. to measurement accuracy with the ± 2 V f.s. setting. Add $\pm 1.0\%$ f.s. to measurement accuracy at the ± 1 V f.s. setting. Specified assuming DC to 50 kHz output. Analog output: Add $\pm 0.2\%$ f.s. to the measurement accuracy of output measurement items (DC level).
Temperature coefficient	$\pm 0.05\%$ f.s. / °C

Display section

Display characters	Japanese, English, Simplified Chinese, Traditional Chinese
Display	10.1" WXGA TFT color LCD (1280 × 800 dots)
Dot pitch	0.1695 (V) mm × 0.1695 (H) mm
Display value resolution	999999 count (including integrated values)
Display refresh rate	Measured values: Approx. 200 ms (independent of internal data update interval) Waveforms: Based on waveform recording settings
Screens	Measurement screen, Input Settings screen, System Settings screen, File Operation screen
Warning display	When an input-channel voltage or current peak-over condition is detected, when no synchronization source is detected. Warning icons for all channels will be displayed on any page of the screen.

Instrument controls

Control devices	Power button × 1, rubber keys × 23, rotary knobs × 2, touchscreen
Touch panel	Analog resistive film
File operations	Displaying data list stored on a USB flash drive, formatting a USB flash drive, creating new folders, renaming folders/files, copying/deleting files, updating the firmware, displaying screenshots, creating/loading settings files

External interface

(1) USB flash drive interface	
Connector	USB Type A receptacle connector × 1
Electrical specifications	USB 3.0 (SuperSpeed)
Connected device	USB flash drive
Recorded data	Saving/loading settings files Saving measured values and automatically recorded data Saving waveform data and screenshots
(2) LAN interface	
Connector	RJ-45 connector × 1
Electrical specifications	IEEE 802.3 compliant
Transmission method	100Base-TX, 1000Base-T (automatic detection)
Protocol	TCP/IP (with DHCP function)
Functions	HTTP server (remote operation) Dedicated port (data transfer, command control) FTP server (file transfer) FTP client Modbus/TCP server XCP on Ethernet (compliant with ASAM e.V.MCD-1 v 1.5.0)
Recommended cable	Category 6A or higher STP cable, max. cable length 5 m
(3) USB (function)	
Connector	Series Mini B receptacle × 1
Electrical specifications	USB2.0 (Full Speed / High Speed)
Class	Proprietary (USB488h)
Connected device	Computer (Windows 10 (32-bit, 64-bit) / Windows 11 (64-bit))
Functions	Data transfer, command control, USB mass storage LAN cannot be used simultaneously. If connected simultaneously, the USB connection will take priority. Operation and communication are not possible during USB mass storage
(4) External control interface	
Connector	4-terminal screwless terminal block × 1
Pin assignments	No. 1 pin: Ground No. 2 pin: Data reset No. 3 pin: Hold No. 4 pin: Start/stop
Electrical specifications	Logic signal of 0 / 5 V (2.5 V to 5 V) or contact signals by shorting/opening the terminal
Functions	Same operation as the START/STOP key, DATA RESET key, or HOLD key on the control panel
(5) BNC sync. interface	
Connector	BNC
Number of instruments that can be synchronized	8 (one primary and seven secondary)
Functionality	Primary instrument Transmitting control signals to secondary instruments Secondary instruments Synchronizing the following functions and operations with those of the primary instrument <ul style="list-style-type: none"> • Timing of internal calculations and data updating • Starting and stopping integration and resetting integration data • Freezing displays (HOLD/PEAK HOLD) and updating data during the display freeze • Zero adjustment • Operating the instrument using the SAVE and SCREEN SHOT keys • Present time (Synchronizable items cannot be controlled; their settings cannot be change during synchronization) The primary and secondary instruments can synchronize only when they have the same settings of the measurement mode and data update interval; those with a data update interval of 10 ms or less cannot.

(6) CAN/CAN FD interface

Protocol	CAN (classical) CAN FD (in conformity with ISO 11898-1:2015) CAN FD (not in conformity with ISO)		
Functionality	Data output Data input		
CAN ports	1 port		
CAN transceiver	MCP2544 FD		
Communications connector	D-sub 9-pin connector (male) Locking screw (hexagonal pillar): Inch screw #4-40 UNC		
Common data I/O settings	Baud rate	CAN 125 k, 250 k, 500 k, 1 Mbps CAN FD Arbitration area: 500 k, 1 M bps Data area: 500 k, 1 M, 2 M, 4 M bps	
	Sample point setting	0.0% to 99.9%	
	Terminal resistance	ON/OFF Resistance value: 120 Ω ± 10 Ω	
	ISO15765-2	ON/OFF	
Data output settings	Data frame output	Continuous	
	Output interval	1 ms, 10 ms, 50 ms, 100 ms, 200 ms, 500 ms, 1 s, 5 s, 10 s, 15 s, 30 s, 1 min, 5 min, 10 min, 15 min, 30 min, 60 min With an error of ± 1 ms from each data update interval setting However, the interval cannot be set to less than the data update interval. The output interval of 500 ms is unavailable with the data update interval of 200 ms.	
	Repeated output count	0 to 10000 (0: infinite)	
	Format	Standard, extended	
	Setting ID	Standard format: 0x000 to 0x7FF Extended format: 0x00000000 to 0x1FFFFFFF	
	Data conversion	Measured data: Floating-point type (IEEE Float: 4 bytes) Output count, output time: Unsigned integer	
	Byte order (Endianness)	Intel (little-endian)	
Data input settings	Number of receiving channels: Up to 20		
	Receiving channel definition	Format	Standard / Extended
		ID	Standard format: 0x000 to 0x7FF Extended format: 0x00000000 to 0x1FFFFFFF
		Name	
		Unit	
		Factor / offset	
		Start bit	0 to 5119 (bit)
		Bit length	1 to 64 (bit)
		Data type	Unsigned integer/signed integer/single-precision floating-point/ doubleprecision floating-point
	Byte order	Motorola (big)/Intel (little)	
	No. of transmitted arbitrary frames: Up to 20		
	Arbitrary frame transmission definition	Cyclic transmission	ON/OFF
		Cyclic transmission interval	10 ms, 50 ms, 200 ms, START, STOP
		Format	Standard / extended
		ID	Standard format: 0x000 to 0x7FF Extended format: 0x00000000 to 0x1FFFFFFF
DLC(ISO15765-2 OFF)		CAN: 0 to 8 bytes CAN FD (ISO-compliant / ISO-non-compliant): 0 to 8 bytes, 12, 16, 20, 24, 32, 48, 64 bytes	
Bit length (ISO15765-2 ON)		0 to 41 bytes	
Transmitted data	Entered in hexadecimal		

Functional specifications

AUTO-range function

Functions	The voltage and current ranges for each wiring configuration are automatically switched in response to the input. (excluding motor input ranges)
Operating mode	OFF / ON (selectable for each wiring configuration)

Time control function

Functions	Other functions are controlled based on the time. Timer control, real time control
Operation	Timer control: Stops once the set amount of time has elapsed. Real time control: Starts at the specified time and stops at the specified time.
Timer control	OFF, 1 s to 9999 h 59 m 59 s (in 1 s increments)
Actual time control	OFF, start time, stop time (in 1 s increments)

Hold function

(1) Hold

Functions	Stops updating display of all measured values, freezing the presently on-screen figures. However, updating continues for waveforms, the clock, and on-screen peak-over conditions. Internal calculations, for example integration and averaging, continue. Cannot be used in combination with the peak hold function.
Output data	Hold data is output for analog output and save data during hold operation. However, waveform output continues.

(2) Peak hold

Functions	The display is updated by replacing all measured values with the maximum values obtained by comparing the absolute values for each measured value. However, the waveform display and integrated values continue to be updated by being replaced with instantaneous data. During average operation, the maximum value affects values measured after averaging. Cannot be used in combination with the hold function.
Output data	Peak hold data is output for analog output and save data during peak hold operation. However, waveform output continues.

Calculation function

(1) Rectifier

Functions	The voltage and current values used to calculate apparent and reactive power and power factor can be selected.
Operating mode	rms / mean (Can be selected for each wiring configuration's voltage and current.)

(2) Scaling

Functions	The VT ratio and CT ratio can be set so that they can affect measured values.
VT (PT) ratio	Can be set for each wiring configuration. 0.00001 to 9999.99 (The settings cannot be configured such that (VT × CT) is greater than 1.0E+06.)
CT ratio	Can be set for each channel. 0.00001 to 9999.99 (The settings cannot be configured such that (VT × CT) is greater than 1.0E+06.)

(3) Averaging (AVG)

Functions	All instantaneous measured values, including harmonics, are averaged. (except peak values, integrated values, and harmonic data updated every 10 ms. When the data update rate is set to 1 ms, all averaging is not performed.)			
Operating mode	Off, exponential average, moving average			
Exponential averaging response rate	Averaging count	FAST	MID	SLOW
	10 ms	0.1 s	0.8 s	5 s
	50 ms	0.5 s	4 s	25 s
	200 ms	2.0 s	16 s	100 s
These values indicate the time required for the final stabilized value to converge on the range of ± 1% when the input changes from 0% to 90% of the range. Although harmonic data is not averaged when the data update interval is set at 10 ms, harmonic data contained in basic measurement items is averaged using the exponential average coefficient every 10 ms. The speed is fixed in IEC measurement mode.				
No. of moving average iterations	2, 4, 8, 16, 32, 64 times			

(4) Efficiency and loss calculations		
Functions	The efficiency η (%) and loss (W) of each channel are calculated between wiring configurations' active power values.	
Calculated items	Active power value (P), fundamental wave active power (Pfund), motor power (Pm), and userdefined formula (UDF) of each channel and wiring configuration	
Number of calculations that can be performed	Four for each efficiency and loss	
Modes	Fixed mode: In the case of items set on the input and output sides, the position in the equation is fixed, regardless of the measured value. Auto mode: In the case of items set on the input and output sides, the position in the equation changes according to the positive and negative of the measured value.	
Equations	Fixed mode: Calculation items can be substituted for Pin(n) and Pout(n). Pin = Pin1 + Pin2 + Pin3 + Pin4 + Pin5 + Pin6 Pout = Pout1 + Pout2 + Pout3 + Pout4 + Pout5 + Pout6 $\eta = 100 \times Pout / Pin $, Loss = Pin - Pout Auto mode: Pin = (Sum of the absolute values of the positive parameter of the input and that of the negative parameter of the output) Pout = (Sum of the absolute values of the positive parameter of the output and that of the negative parameter of the input) $\eta = 100 \times Pout / Pin $, Loss = Pin - Pout	
(5) User-defined calculations		
Functions	Calculates specified equations into which set basic measurement items are substituted. No calculation can be performed if the data update interval is set to 1 ms.	
Calculation terms	Basic measurement items or 16 terms of constants with up to 6 digits, where the operators are the four fundamental operations UDFn = ITEM1 <input type="checkbox"/> ITEM2 <input type="checkbox"/> ITEM3 <input type="checkbox"/> ITEM4 <input type="checkbox"/> ... <input type="checkbox"/> ITEM16 ITEMn: Basic measurement items (including UDFn) or constants of up to six digits The <input type="checkbox"/> characters indicate one of the following operators: plus sign (+), minus sign (-), multiplication sign (*), and division sign (/). ITEMn functions: Neg (negative sign), sin, cos, tan, abs, log10 (common logarithm), log (logarithm), exp, sqrt, asin, acos, atan, sqr Equations UDFns are calculated in the order of letters n; if a letter n on the right-hand side of an equation is more than that on the left-hand side, the previously calculated value is substituted.	
Number of equations	20 (UDF1 to UDF20)	
Maximum value setting	Set Fixed or Auto for each UDFn. Fixed: Can be set within the range of 1.000 n to 999.999 T. Auto: The first 6 digits are always displayed. (effective display range: 0 to \pm 999.999 Y) The maximum value operates as a range of the UDFn.	
UDF name and units	Up to 8 ASCII characters per UDFn	
Integration	OFF/Positive/Negative/Total Can be set for each UDFn Off: Displays the calculated value of the UDFn. Positive: Displays the integrated value of the polarity (+) of the UDFn calculation value in UDFn. Negative: Displays the integrated value of the polarity (-) of the UDFn calculation value in UDFn. Total: Displays the integrated value of the UDFn equation in UDFn. (effective display range: 0 to \pm 999.999 Y) Other values are not added if the integrated value exceeds the effective display range.	
(6) Delta conversion		
Functions	Δ -Y	When using a 3P3W3M or 3V3A wiring method, it converts the line voltage waveform to a phase voltage waveform using a virtual neutral point.
	Y- Δ	When using a 3P4W wiring method, it converts the phase voltage waveform to a line voltage waveform. Voltage RMS values and all voltage parameters, including harmonics, are calculated using the post-conversion voltage. However, peak-exceeded events are judged using pre-conversion values.
(7) Power formula selection		
Functions	Equations for reactive power, power factor, and power phase angle can be selected.	
Formula	Type 1, Type 2, Type 3 Type 1: Compatible with the Type 1 for each of the PW3390, 3193 and 3390. Type 2: Compatible with the Type 2 for each of the 3192 and 3193. Type 3: The active power's sign can be used as the power factor's sign. (Type 1, Type 2, and Type 3 are compatible with each equation of the PW8001, PW6001.)	
(8) Current sensor phase shift calculation		
Functions	Current sensor harmonic phase characteristics can be compensated using calculations.	
Operating modes	OFF / ON / AUTO (set for each channel) Automatic mode can be selected when a current sensor with the automatic recognition function is connected.	
Compensation value settings	Compensation points can be set using frequencies and phase differences. Frequency: 0.1 kHz to 5000.0 kHz (in 0.1 kHz increments) Phase difference: 0.000° to \pm 180.000° (in 0.001° increments) The compensation value is automatically set when the current sensor is connected in the automatic operation mode.	
Max. correction range	Approx. 60 μ s	
(9) Voltage probe phase shift calculation		
Functions	Voltage probes harmonic phase characteristics can be compensated using calculations.	
Operating modes	OFF / ON (can be set for each channel)	
Compensation value settings	Compensation points can be set using frequencies and phase differences. Frequency: 0.1 kHz to 5000.0 kHz (in 0.1 kHz increments) Phase difference: 0.000° to \pm 180.000° (in 0.001° increments)	
Max. correction range	Approx. 60 μ s	

PW4001

Display function

(1) Wiring method confirmation screen	
Functions	Wiring diagrams as well as vector diagrams of voltage and current (for wiring configurations other than the singlephase wiring configuration only) can be displayed based on the selected measured line patterns. The on-screen vector diagram shows the vector ranges for correct connections, enabling the operator to check for proper connections.
Mode at startup	The setting can be made so that the instrument always show the wiring configuration confirmation screen at startup (startup screen setting).
Simple settings	Settings can be switched over those appropriate for objects under measurement selected for each wiring configuration. 50/60 Hz, DC/WLTP, PWM, HIGH FREQ, GENERAL.
(2) Vector display screen	
Functions	The screen can display wiring-specific vector graphs along with associated level values and phase angles. The display orders and vector magnification can be selected.
Display patterns	1-vector-diagram: Vectors can be drawn for up to four channels. 2-vector-diagram, 4-vector-diagram: Vectors can be drawn for each selected wiring configuration.
(3) Numerical display screen	
Functions	The screen can display measured power values and motor values for up to four installed channels.
Display patterns	Basic display for each wiring configuration: The screen can display measured values of the lines under measurement and motors connected to the instrument. In addition to the four patterns, U, I, P, and Integ as well as motor is available. On-screen values are linked to the channel indicators. Selective display: The screen can display values of any measurement items selected from all basic measurement items at any positions. There are 8-, 16-, 36-, and 64-display patterns available.
(4) Harmonic display screen	
Functions	The screen can display measured harmonic values.
Display patterns	Bar-graph display: The screen can display measured harmonic items for user-specified channels as bar graphs. (up to 500th) List display: The screen can display numerical values for user-specified parameters of user-specified channels.
(5) Waveform display screen	
Functions	The screen can display the motor waveform as well as the voltage and current waveforms.
Display patterns	All-waveform display Waveform+numerical value display Zoom-display cursor measurement supported

Trend graph function

Functions	Displays a graph of measured values selected as output parameters in a time series. The waveform is plotted by compressing the data at the data update interval using peak-topeak compression based on the time axis setting, and without the data being stored
Operation	Use the START/STOP key to start or stop plotting. Display values are plotted during hold or peak hold. Plotted data can be cleared by pressing the DATA RESET key after stopping using the STOP key, or by changing the time axis setting.
Plotted items	Up to 8 items
Time axis	50 ms/div to 24 h/div, plotting area: 20 div
Vertical axis	Auto scale (adjusts to fit data within the time axis display range within the screen), Manual (maximum and minimum display values are set by the user)

Automatic data save function

Functions	Saves the user-specified measured values every user-specified interval
Auto-save control	OFF/ON
Save destination	USB flash drive, internal memory (capacity approx.: 15 GB) Select the media to be used for saving when auto-save control is on. If there is no USB flash drive, saving will take place on the internal memory. A folder created on a USB flash drive or in the internal memory can be specified as the destination to save data.
Saved parameters	Selectable from all measured values, including measured harmonic values. Harmonic readings are not saved automatically when the interval is set to 1 ms.
Interval	OFF, 1 ms, 10 ms, 50 ms, 100 ms, 200 ms, 500 ms, 1 s, 5 s, 10 s, 15 s, 30 s, 1 min, 5 min, 10 min, 15 min, 30 min, 60 min However, the interval cannot be set to less than the data update interval.
Max. savable data	Approx. 500 MB per file (automatically segmented) × 1000 files
Data format	CSV: Measured data is delimited with commas (,) and periods (.) represent decimal points. SSV: Measured data is delimited with semicolons (;) and commas (,) represent decimal points. BIN: Common file-format that can be loaded by GENNECT One
Filename	Automatically generated based on the time and date at which measurement started.

Manual data save function

(1) Measurement data

Functions	Pressing the SAVE key can save values measured at the moment. The data is outputted to the same file until the setting is changed, or the DATA RESET key is pressed.
Save destination	USB flash drive, internal memory
Saved parameters	Selectable from all measured values, including measured harmonic values.
Max. save data	500 MB per file (automatically segmented)
Data format	CSV, SSV

(2) Waveform data

Functions	When the Save button is tapped on the waveform screen of the touchscreen, the waveform is saved in the specified format.
Save destination	USB flash drive, internal memory
Saved parameters	Waveform data on the waveform screen
Max. save data	Approx. 400 MB (in binary format) Approx. 2 GB (in text format)
Data format	CSV, SSV, BIN, MAT

(3) Screenshots

Functions	Pressing the SCREEN SHOT key can save the screen displayed at the moment in PNG format. Setting list screenshot function Comment entering function Free drawing function
Save destination	USB flash drive, internal memory, FTP server
Saved parameters	Screenshot data
Data format	PNG

(4) Settings data

Functions	Saves various settings information as settings files using the [FILE] screen. In addition, loading a settings file saved using the [FILE] screen can restore settings. However, the language and communications settings are not restored. Settings data can be opened with the image viewer because it is inserted into an image that displays a settings list.
Save destination	USB flash drive, internal memory, FTP server
Saved parameters	Setting data
Data format	SET

(5) CAN output settings data

Functions	Data-output settings can be saved as DBC-files using the [CAN] screen.
Save destination	USB flash drive, internal memory, FTP server
Saved parameters	Output settings data
Data format	DBC

(6) User-defined equation data

Functions	User-defined formulas can be saved as JSON files using the [UDF] screen. Loading a JSON file saved using the [UDF] or [FILE] screen can restore the equations. Calculation is not possible if the loaded equations include calculation items that are invalid (items that cannot be selected according to the module, option configuration, or other setting). ([-----] is displayed)
Save destination	USB flash drive, internal memory, FTP server
Saved parameters	User-defined formula
Data format	JSON

PW4001

Other functions





Clock function	Auto-calendar, automatic leap-year detection, 24-hour clock
Actual time accuracy	When the instrument is turned on: ± 100 ppm When the instrument is turned off: Within ± 3 s/day (at 25° C)
Sensor identification	Current sensors connected to input modules can be identified automatically. The instrument can detect sensor ranges and the connection/disconnection of sensors, displaying warning dialog boxes. Data compensation values provided by current sensors affect phase compensation data.
Zero suppression function	Selectable between OFF and ON. ON: 0.01 ~ 1.00 % of full scale When this function is ON, values of measurement items less than the set value are replaced with zero.

Environment and safety specifications

Operating environment	Indoor use, pollution level 2, altitude up to 2000 m
Operating temperature and humidity	-20° C to 50° C (-4° F to 122° F), 80% RH or less (after warm-up, non-condensing) If used at temperatures below 0° C (32° F), warm up in a 0° C to 50° C (32° F to 122° F) environment prior to use.
Storage temperature and humidity	-20° C to 50° C (-4° F to 122° F), 80% RH or less (non-condensing)
Standards	Safety EN61010 EMC EN 61326 Class A
Vibration resistance	JIS D 1601:1995 5.3 (1) Type 1: Passenger cars, Condition: Equivalent to Type A Vibration acceleration: 45 m/s ² (4.6 G) for 4 h in the X direction and 2 h in the Y and Z directions
Power supply	Commercial power supply Rated supply voltage: 100 V to 240 V AC (Assuming voltage fluctuation of $\pm 10\%$) Rated power-supply frequency: 50 Hz, 60 Hz Anticipated transient overvoltage: 2500 V Maximum rated power: 120 VA Typical power consumption (reference value): 47 W (Conditions: Power supply voltage of 100 V/60 Hz. Voltage of 800 V DC and current of 200 A DC (CT6834) measured on all channels.) DC power supply (optional) Rated supply voltage: 10.5 V to 28 V DC (Operating temperature range: - 20° C to 40° C) 10.5 V to 20 V DC (Operating temperature range: 40° C to 50° C) Maximum rated power: 95 VA
Backup battery life	Lithium battery About 10 years (Reference value at 23° C) Time and setting conditions
Dimensions	361 \pm 2 (W) \times 176 \pm 2 (H) \times 135 \pm 2 (H) mm (14.21 \pm 0.08 (W) \times 6.93 \pm 0.08 (H) \times 5.31 \pm 0.08 (D) in) (excluding protruding parts)
Weight	Approx. 4.6 kg (162.26 oz.) (for PW4001-05)
Product warranty period	3 years

High-accuracy clamp current sensors

Product warranty period: 3 year (1 year for the CT6847A only) Guaranteed accuracy period: 1 year

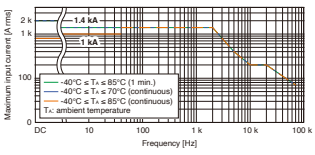
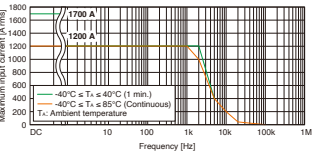
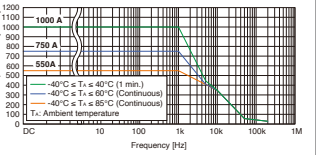
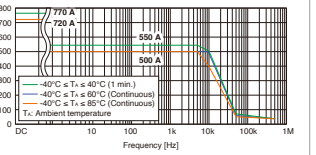
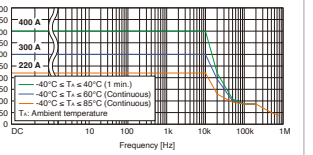
Model	CT6847A	CT6846A	CT6845A	CT6844A	CT6843A
Appearance	NEW 				
Rated current	DC 2000 A, AC 1400 A	1000 A AC/DC	500 A AC/DC	500 A AC/DC	200 A AC/DC
Frequency band	DC to 70 kHz	DC to 100 kHz	DC to 200 kHz	DC to 500 kHz	DC to 700 kHz
Diameter of measurable conductors	Max. ϕ 50 mm (1.97 in.)	Max. ϕ 50 mm (1.97 in.)	Max. ϕ 50 mm (1.97 in.)	Max. ϕ 20 mm (0.79 in.)	Max. ϕ 20 mm (0.79 in.)
Accuracy	PW4001 Combined*1 Current (I), Active power (P)				
	Sensor only (amplitude)*2				
DC	$\pm 0.18\% \pm 0.02\%$	$\pm 0.23\% \pm 0.03\%$	$\pm 0.23\% \pm 0.03\%$	$\pm 0.23\% \pm 0.03\%$	$\pm 0.23\% \pm 0.03\%$
45 Hz $\leq f \leq 66$ Hz	$\pm 0.18\% \pm 0.02\%$	$\pm 0.23\% \pm 0.02\%$	$\pm 0.23\% \pm 0.02\%$	$\pm 0.23\% \pm 0.02\%$	$\pm 0.23\% \pm 0.02\%$
DC	$\pm 0.15\% \pm 0.01\%$	$\pm 0.2\% \pm 0.02\%$	$\pm 0.2\% \pm 0.02\%$	$\pm 0.2\% \pm 0.02\%$	$\pm 0.2\% \pm 0.02\%$
DC < f ≤ 16 Hz	$\pm 0.2\% \pm 0.01\%$	$\pm 0.2\% \pm 0.01\%$	$\pm 0.2\% \pm 0.01\%$	$\pm 0.2\% \pm 0.01\%$	$\pm 0.2\% \pm 0.01\%$
16 Hz < f ≤ 100 Hz	$\pm 0.15\% \pm 0.01\%$	$\pm 0.5\% \pm 0.02\%$	$\pm 0.3\% \pm 0.02\%$	$\pm 0.3\% \pm 0.02\%$	$\pm 0.3\% \pm 0.02\%$
100 Hz < f ≤ 500 Hz	$\pm 0.5\% \pm 0.02\%$	$\pm 1.0\% \pm 0.02\%$	$\pm 0.5\% \pm 0.02\%$	$\pm 0.5\% \pm 0.02\%$	$\pm 0.5\% \pm 0.02\%$
500 Hz < f ≤ 1 kHz	$\pm 1.0\% \pm 0.02\%$	$\pm 2.0\% \pm 0.02\%$	$\pm 1.0\% \pm 0.02\%$	$\pm 1.0\% \pm 0.02\%$	$\pm 1.0\% \pm 0.02\%$
1 kHz < f ≤ 5 kHz	$\pm 2.0\% \pm 0.02\%$	$\pm 5.0\% \pm 0.02\%$	$\pm 1.5\% \pm 0.02\%$	$\pm 1.5\% \pm 0.02\%$	$\pm 1.5\% \pm 0.02\%$
5 kHz < f ≤ 20 kHz	$\pm (0.45 \times f)\% \pm 0.02\%^{*4}$	$\pm 30\% \pm 0.02\%$	$\pm 5.0\% \pm 0.02\%$	$\pm 5.0\% \pm 0.02\%$	$\pm 5.0\% \pm 0.02\%$
20 kHz < f ≤ 50 kHz	$\pm (0.45 \times f)\% \pm 0.05\%^{*4}$	-	$\pm 10\% \pm 0.05\%$	$\pm 15\% \pm 0.05\%$	$\pm 10\% \pm 0.05\%$
50 kHz < f ≤ 100 kHz	-	-	$\pm 30\% \pm 0.05\%$	$\pm 30\% \pm 0.05\%$	$\pm 15\% \pm 0.05\%$
100 kHz < f ≤ 300 kHz	-	-	-	-	$\pm 30\% \pm 0.05\%$
300 kHz < f ≤ 500 kHz	-	-	-	-	$\pm 30\% \pm 0.05\%$
Common-Mode Rejection Ratio (CMRR)	130 dB or greater (DC to 1 kHz) 120 dB or greater (1 kHz to 10 kHz) 100 dB or greater (10 kHz to 50 kHz) (effect on output voltage and common mode voltage)	150 dB or greater (DC to 1 kHz) 130 dB or greater (1 kHz to 10 kHz) 100 dB or greater (10 kHz to 50 kHz) (effect on output voltage and common mode voltage)	150 dB or greater (DC to 1 kHz) 130 dB or greater (1 kHz to 10 kHz) 100 dB or greater (10 kHz to 100 kHz) (effect on output voltage and common mode voltage)	150 dB or greater (DC to 1 kHz) 135 dB or greater (1 kHz to 10 kHz) 120 dB or greater (10 kHz to 100 kHz) 100 dB or greater (100 kHz to 300 kHz) (effect on output voltage and common mode voltage)	150 dB or greater (DC to 1 kHz) 135 dB or greater (1 kHz to 10 kHz) 115 dB or greater (10 kHz to 100 kHz) 95 dB or greater (100 kHz to 500 kHz) (effect on output voltage and common mode voltage)
Linearity errors (typical)	± 20 ppm	± 20 ppm	± 20 ppm	± 20 ppm	± 20 ppm
Frequency derating					
Output voltage	1 mV/A (= 2 V/2000 A)	2 mV/A (= 2 V/1000 A)	4 mV/A (= 2 V/500 A)	4 mV/A (= 2 V/500 A)	10 mV/A (= 2 V/200 A)
Operating temperature and humidity*3	-40° C to 85° C (-40° F to 185° F), 80% RH or less	-40° C to 85° C (-40° F to 185° F), 80% RH or less	-40° C to 85° C (-40° F to 185° F), 80% RH or less	-40° C to 85° C (-40° F to 185° F), 80% RH or less	-40° C to 85° C (-40° F to 185° F), 80% RH or less
Storage temperature and humidity*3	-40° C to 85° C (-40° F to 185° F), 80% RH or less	-40° C to 85° C (-40° F to 185° F), 80% RH or less	-40° C to 85° C (-40° F to 185° F), 80% RH or less	-40° C to 85° C (-40° F to 185° F), 80% RH or less	-40° C to 85° C (-40° F to 185° F), 80% RH or less
Withstand voltage	4260 V AC Withstand test current of 1 mA, 50/60 Hz, 1 min., between jaws and cable output terminal	4260 V AC Withstand test current of 1 mA, 50/60 Hz, 1 min., between jaws and cable output terminal	4260 V AC Withstand test current of 1 mA, 50/60 Hz, 1 min., between jaws and cable output terminal	4260 V AC Withstand test current of 1 mA, 50/60 Hz, 1 min., between jaws and cable output terminal	4260 V AC Withstand test current of 1 mA, 50/60 Hz, 1 min., between jaws and cable output terminal
Standards	Safety: EN 61010, EMC: EN 61326	Safety: EN 61010, EMC: EN 61326	Safety: EN 61010, EMC: EN 61326	Safety: EN 61010, EMC: EN 61326	Safety: EN 61010, EMC: EN 61326
Cable length	Approx. 3 m (9.84 ft.)	Approx. 3 m (9.84 ft.)	Approx. 3 m (9.84 ft.)	Approx. 3 m (9.84 ft.)	Approx. 3 m (9.84 ft.)
Dimensions	Approx. 238W × 116H × 35D mm (approx. 9.37W × 4.57H × 1.38D in.)	Approx. 238W × 116H × 35D mm (approx. 9.37W × 4.57H × 1.38D in.)	Approx. 238W × 116H × 35D mm (approx. 9.37W × 4.57H × 1.38D in.)	Approx. 153W × 67H × 25D mm (approx. 6.02W × 2.64H × 0.98D in.)	Approx. 153W × 67H × 25D mm (approx. 6.02W × 2.64H × 0.98D in.)
Mass	Approx. 1040 g (36.7 oz.)	Approx. 990 g (34.9 oz.)	Approx. 860 g (30.3 oz.)	Approx. 400 g (14.1 oz.)	Approx. 380 g (13.4 oz.)

*1: \pm (% of reading + % of range), range is PW4001 *2: \pm (% of reading + % of full scale), full scale is rated current of sensor *3: Non-condensing

High-accuracy clamp current sensors

Product warranty period: 3 year Guaranteed accuracy period: 1 year (CT6841A, CT6831, CT6830) / Product warranty period: 1 year Guaranteed accuracy period: 1 year (CT6834, CT6834-01, CT6833, CT6833-01)

Model	CT6841A	CT6831	CT6830	CT6834, CT6834-01	CT6833, CT6833-01	
Appearance		NEW	NEW	NEW	NEW	
Rated current	20 A AC/DC	20 A AC/DC	2 A AC/DC	500 A AC/DC	200A AC/DC	
Frequency band	DC to 2 MHz	DC to 100 kHz	DC to 100 kHz	DC to 50 kHz	DC to 50 kHz	
Diameter of measurable conductors	Max. ϕ 20 mm (0.79 in.)	Max. ϕ 5 mm (0.20 in.)	Max. ϕ 5 mm (0.20 in.)	Max. ϕ 20 mm (0.79 in.)	Max. ϕ 20 mm (0.79 in.)	
Accuracy	PW4001 Combined*1 Current (I), Active power (P)		PW4001 accuracy + Sensor accuracy		PW4001 accuracy + Sensor accuracy	
	DC : $\pm 0.23\% \pm 0.06\%$		DC : $\pm 0.3\% \pm 0.10\%$		DC : $\pm 0.3\% \pm 0.10\%$	
	45 Hz $\leq f \leq 66$ Hz : $\pm 0.23\% \pm 0.02\%$		DC < f ≤ 66 Hz : $\pm 0.3\% \pm 0.01\%$		DC < f ≤ 66 Hz : $\pm 0.3\% \pm 0.05\%$	
	DC : $\pm 0.2\% \pm 0.05\%$		DC < f ≤ 100 Hz : $\pm 0.2\% \pm 0.01\%$		DC < f ≤ 16 Hz : $\pm 0.15\% \pm 0.01\%$	
	DC < f ≤ 100 Hz : $\pm 0.2\% \pm 0.01\%$		66 Hz < f ≤ 500 Hz : $\pm 0.3\% \pm 0.02\%$		16 Hz $\leq f \leq 66$ Hz : $\pm 0.07\% \pm 0.007\%$	
	100 Hz < f ≤ 500 Hz : $\pm 0.3\% \pm 0.02\%$		500 Hz < f ≤ 1 kHz : $\pm 0.5\% \pm 0.05\%$		66 Hz < f ≤ 100 Hz : $\pm 0.07\% \pm 0.007\%$	
	500 Hz < f ≤ 1 kHz : $\pm 0.5\% \pm 0.02\%$		1 kHz < f ≤ 5 kHz : $\pm 1.0\% \pm 0.10\%$		100 Hz < f ≤ 500 Hz : $\pm 0.1\% \pm 0.01\%$	
	1 kHz < f ≤ 5 kHz : $\pm 1.0\% \pm 0.02\%$		5 kHz < f ≤ 10 kHz : $\pm 5.0\% \pm 0.10\%$		500 Hz < f ≤ 1 kHz : $\pm 0.25\% \pm 0.02\%$	
	5 kHz < f ≤ 10 kHz : $\pm 1.5\% \pm 0.02\%$		10 kHz < f ≤ 100 kHz : $\pm 30\% \pm 0.10\%$		1 kHz < f ≤ 20 kHz : $\pm (0.25\% \times f) \pm 0.02\%^{**}$	
	10 kHz < f ≤ 50 kHz : $\pm 2.0\% \pm 0.02\%$		-		-	
	50 kHz < f ≤ 100 kHz : $\pm 5.0\% \pm 0.05\%$		-		-	
	100 kHz < f ≤ 300 kHz : $\pm 10\% \pm 0.05\%$		-		-	
300 kHz < f ≤ 500 kHz : $\pm 15\% \pm 0.05\%$		-		-		
500 kHz < f < 1 MHz : $\pm 30\% \pm 0.05\%$		-		-		
Common-Mode Rejection Ratio (CMRR)	140 dB or greater (DC to 1 kHz) 125 dB or greater (1 kHz to 10 kHz) 100 dB or greater (10 kHz to 100 kHz) 80 dB or greater (100 kHz to 1 MHz) (effect on output voltage and common mode voltage)	140 dB or greater (DC to 100 Hz) 130 dB or greater (100 Hz to 1 kHz) (effect on output voltage and common mode voltage)	140 dB or greater (DC to 100 Hz) 125 dB or greater (100 Hz to 1 kHz) (effect on output voltage and common mode voltage)	150 dB or greater (DC to 1 kHz) 130 dB or greater (1 kHz to 10 kHz) 120 dB or greater (10 kHz to 50 kHz) (effect on output voltage and common mode voltage)	150 dB or greater (DC to 1 kHz) 130 dB or greater (1 kHz to 10 kHz) 120 dB or greater (10 kHz to 50 kHz) (effect on output voltage and common mode voltage)	
Linearity errors (typical)	± 20 ppm	-	-	-	-	
Frequency derating						
Output voltage	100 mV/A (= 2 V/20 A)	0.1 V/A (= 2 V/20 A)	1 V/A	4 mV/A	10 mV/A	
Operating temperature and humidity*3	-40° C to 85° C (-40° F to 185° F), 80% RH or less	Sensor: -40° C to 85° C (-40° F to 185° F), 80% RH or less Relay box: -25° C to 50° C (-77° F to 122° F), 80% RH or less	Sensor: -40° C to 85° C (-40° F to 185° F), 80% RH or less Relay box: -25° C to 50° C (-77° F to 122° F), 80% RH or less	Sensor, cable: -40° C to 85° C (-40° F to 185° F), 80% RH or less Relay box: -25° C to 50° C (-13° F to 122° F), 80% RH or less	Sensor, cable: -40° C to 85° C (-40° F to 185° F), 80% RH or less Relay box: -25° C to 50° C (-13° F to 122° F), 80% RH or less	
Storage temperature and humidity*3	-40° C to 85° C (-40° F to 185° F), 80% RH or less	Sensor and relay box: -25° C to 50° C (-77° F to 122° F), 80% RH or less	Sensor and relay box: -25° C to 50° C (-77° F to 122° F), 80% RH or less	Sensor and relay box: -25° C to 50° C (-13° F to 122° F), 80% RH or less	Sensor and relay box: -25° C to 50° C (-13° F to 122° F), 80% RH or less	
Withstand voltage	4260 V AC Withstand test current of 1 mA, 50/60 Hz, 1 min., between jaws and cable output terminal	-	-	-	-	
Standards	Safety: EN 61010, EMC: EN 61326	Safety: EN 61010, EMC: EN 61326	Safety: EN 61010, EMC: EN 61326	Safety: EN 61010, EMC: EN 61326	Safety: EN 61010, EMC: EN 61326	
Cable length	Approx. 3 m (9.84 ft.)	Between sensor to relay box: approx. 4 m (13.12 ft.) Between relay box to output connector: approx 0.2 m (0.66 ft.)	Between sensor to relay box: approx. 4 m (13.12 ft.) Between relay box to output connector: approx 0.2 m (0.66 ft.)	CT6834: approx. 5 m (16.40 ft.) including relay box CT6834-01: approx 10 m (32.81 ft.) including relay box	CT6833: approx. 5 m (16.40 ft.) including relay box CT6833-01: approx 10 m (32.81 ft.) including relay box	
Dimensions	Approx. 153W × 67H × 25D mm (Approx. 6.02W × 2.64H × 0.98D in.)	Sensor: Approx. 76.5W × 23.4H × 14.2D mm (approx. 3.00W × 0.92H × 0.56D in.) Relay box: Approx. 80W × 20H × 26.5D mm (approx. 3.15W × 0.79H × 1.04D in.)	Sensor: Approx. 76.5W × 23.4H × 14.2D mm (approx. 3.00W × 0.92H × 0.56D in.) Relay box: Approx. 80W × 20H × 26.5D mm (approx. 3.15W × 0.79H × 1.04D in.)	Sensor: approx. 149W × 46H × 16.5D mm (approx. 5.87W × 1.81H × 0.65D in.) Relay box: approx. 126W × 57H × 20.5D mm (approx. 4.96W × 2.24H × 0.81D in.)	Sensor: approx. 149W × 46H × 16.5D mm (approx. 5.87W × 1.81H × 0.65D in.) Relay box: approx. 126W × 57H × 20.5D mm (approx. 4.96W × 2.24H × 0.81D in.)	
Mass	Approx. 370 g (13.1 oz.)	Approx. 160 g (5.64 oz.)	Approx. 160 g (5.64 oz.)	CT6834: approx. 500 g (17.64 oz.) CT6834-01: approx. 710 g (25.05 oz.)	CT6833: approx. 500 g (17.64 oz.) CT6833-01: approx. 710 g (25.05 oz.)	

*1: \pm (% of reading + % of range), range is PW4001 *2: \pm (% of reading + % of full scale), full scale is rated current of sensor *3: Non-condensing

High-accuracy pass-through current sensors





Product warranty period: 3 year Guaranteed accuracy period: 1 year

Model	CT6877A, CT6877A-1	CT6876A, CT6876A-1	CT6904A	CT6875A, CT6875A-1	
Appearance					
Rated current	AC/DC 2000 A	AC/DC 1000 A	AC/DC 500 A	AC/DC 500 A	
Frequency band	DC ~ 1 MHz	CT6876A: DC ~ 1.5 MHz CT6876A-1: DC ~ 1.2 MHz	CT6904A: DC ~ 4 MHz CT6904A-1: DC ~ 2 MHz	CT6875A: DC ~ 2 MHz CT6875A-1: DC ~ 1.5 MHz	
Diameter of measurable conductors	Max. φ 80 mm (3.14 in.)	Max. φ 36 mm (1.41 in.)	Max. φ 32 mm (1.25 in.)	Max. φ 36 mm (1.41 in.)	
Accuracy	PW4001 Combined*1 Current (I) , Active power (P) Sensor only (amplitude)*2	DC : ± 0.07% ± 0.018%	DC : ± 0.07% ± 0.018%	DC : ± 0.055% ± 0.017%	DC : ± 0.07% ± 0.018%
		45Hz ≤ f ≤ 66Hz : ± 0.07% ± 0.018%	45Hz ≤ f ≤ 66Hz : ± 0.07% ± 0.018%	45Hz ≤ f ≤ 66Hz : ± 0.05% ± 0.017%	45Hz ≤ f ≤ 66Hz : ± 0.07% ± 0.018%
		DC : ± 0.04% ± 0.008%	DC : ± 0.04% ± 0.008%	DC : ± 0.025% ± 0.007%	DC : ± 0.04% ± 0.008%
		DC < f < 16 Hz : ± 0.1% ± 0.02%	DC < f < 16 Hz : ± 0.1% ± 0.02%	DC < f < 16 Hz : ± 0.2% ± 0.02%	DC < f < 16 Hz : ± 0.1% ± 0.02%
		16 Hz ≤ f < 45 Hz : ± 0.05% ± 0.01%	16 Hz ≤ f < 45 Hz : ± 0.05% ± 0.01%	16 Hz ≤ f < 45 Hz : ± 0.1% ± 0.02%	16 Hz ≤ f < 45 Hz : ± 0.05% ± 0.01%
		45 Hz ≤ f ≤ 66 Hz : ± 0.04% ± 0.008%	45 Hz ≤ f ≤ 66 Hz : ± 0.04% ± 0.008%	45 Hz ≤ f ≤ 65 Hz : ± 0.02% ± 0.007%	45 Hz ≤ f ≤ 66 Hz : ± 0.04% ± 0.008%
		66 Hz < f ≤ 100 Hz : ± 0.05% ± 0.01%	66 Hz < f ≤ 100 Hz : ± 0.05% ± 0.01%	65 Hz < f ≤ 850 Hz : ± 0.05% ± 0.007%	66 Hz < f ≤ 100 Hz : ± 0.05% ± 0.01%
		100 Hz < f ≤ 500 Hz : ± 0.1% ± 0.02%	100 Hz < f ≤ 500 Hz : ± 0.1% ± 0.02%	850 Hz < f ≤ 1 kHz : ± 0.1% ± 0.01%	100 Hz < f ≤ 500 Hz : ± 0.1% ± 0.02%
		500 Hz < f ≤ 1 kHz : ± 0.2% ± 0.02%	500 Hz < f ≤ 1 kHz : ± 0.2% ± 0.02%	1 kHz < f ≤ 5 kHz : ± 0.4% ± 0.02%	500 Hz < f ≤ 1 kHz : ± 0.2% ± 0.02%
		1 kHz < f ≤ 10 kHz : ± 0.5% ± 0.02%*4	1 kHz < f ≤ 10 kHz : ± 0.5% ± 0.02%*4	5 kHz < f ≤ 10 kHz : ± 0.4% ± 0.02%	1 kHz < f ≤ 10 kHz : ± 0.4% ± 0.02%*4
10 kHz < f ≤ 50 kHz : ± 1.5% ± 0.05%*4	10 kHz < f ≤ 50 kHz : ± 2% ± 0.05%*4	10 kHz < f ≤ 50 kHz : ± 1% ± 0.02%	10 kHz < f ≤ 50 kHz : ± 1.5% ± 0.05%*4		
50 kHz < f ≤ 100 kHz : ± 2.5% ± 0.05%*4	50 kHz < f ≤ 100 kHz : ± 3% ± 0.05%*4	50 kHz < f ≤ 100 kHz : ± 1% ± 0.05%*5	50 kHz < f ≤ 100 kHz : ± 2.5% ± 0.05%*4		
100 kHz < f ≤ 700 kHz : ± (0.025 × f) ± 0.05%*4	100 kHz < f ≤ 1 MHz : ± (0.025 × f) ± 0.05%*4	100 kHz < f ≤ 300 kHz : ± 2% ± 0.05%*5	100 kHz < f ≤ 1 MHz : ± (0.025 × f kHz)% ± 0.05%*4		
-	-	300 kHz < f ≤ 1 MHz : ± 5% ± 0.05%*5	-		
Common-Mode Rejection Ratio (CMRR)	140 dB or greater (50/60 Hz) 120 dB or greater (100 kHz) (effect on output voltage and common mode voltage)	140 dB or greater (50/60 Hz) 120 dB or greater (100 kHz) (effect on output voltage and common mode voltage)	140 dB or greater (50/60 Hz) 120 dB or greater (100 kHz) (effect on output voltage and common mode voltage)	140 dB or greater (50/60 Hz) 120 dB or greater (100 kHz) (effect on output voltage and common mode voltage)	
Linearity errors (typical)	± 10 ppm	± 5 ppm	± 5 ppm	± 5 ppm	
Offset errors (typical)	± 5 ppm	± 5 ppm	± 10 ppm	± 5 ppm	
Amplitude errors (typical)	(DC) ± 15 ppm, (10 ~ 100 Hz) ± 0.01%, (100 ~ 1 kHz) ± 0.04%, (1 k ~ 10 kHz) ± 0.25%, (10 k ~ 100 kHz) ± 1%, (100 k ~ 300 kHz) ± 2%, (300 k ~ 700 kHz) ± 10%	(DC) ± 10 ppm, (10 ~ 100 Hz) ± 0.005%, (100 ~ 1 kHz) ± 0.03%, (1 k ~ 10 kHz) ± 0.2%, (10 k ~ 100 kHz) ± 1%, (100 k ~ 300 kHz) ± 3%, (300 k ~ 1 MHz) ± 15%	-	(DC) ± 10 ppm, (10 ~ 100 Hz) ± 0.005%, (100 ~ 1 kHz) ± 0.02%, (1 k ~ 20 kHz) ± 0.08%, (20 k ~ 100 kHz) ± 0.5%, (100 k ~ 300 kHz) ± 1%, (300 k ~ 1 MHz) ± 5%	
Frequency derating					
Output voltage	1 mV/A (=2 V/2000 A)	2 mV/A (=2 V/1000 A)	4 mV/A (=2 V/500 A)	4 mV/A (=2 V/500 A)	
Operating temperature and humidity*3	-40° C to 85° C (-40° F to 185° F), 80% RH or less	-40° C to 85° C (-40° F to 185° F), 80% RH or less	-10° C to 50° C (-14° F to 122° F), 80% RH or less	-40° C to 85° C (-40° F to 185° F), 80% RH or less	
Storage temperature and humidity*3	-40° C to 85° C (-40° F to 185° F), 80% RH or less	-40° C to 85° C (-40° F to 185° F), 80% RH or less	-20° C to 60° C (-4° F to 140° F), 80% RH or less	-40° C to 85° C (-40° F to 185° F), 80% RH or less	
Maximum rated voltage to earth	1000 V CATIII anticipated transient overvoltage: 8000 V	1000 V CATIII anticipated transient overvoltage: 8000 V	1000 V CATIII anticipated transient overvoltage: 8000 V	1000 V CATIII anticipated transient overvoltage: 8000 V	
Standards	Safety: EN 61010, EMC: EN 61326	Safety: EN 61010, EMC: EN 61326	Safety: EN 61010, EMC: EN 61326	Safety: EN 61010, EMC: EN 61326	
Cable length	CT6877A: approx. 3 m (9.84 ft.) CT6877A-1: approx. 10 m (32.81 ft.)	CT6876A: approx. 3 m (9.84 ft.) CT6876A-1: approx. 10 m (32.81 ft.)	CT6904A: approx. 3 m (9.84 ft.) (including relay box) CT6904A-1: approx. 10 m (32.81 ft.) (including relay box)	CT6875A: approx. 3 m (9.84 ft.) CT6875A-1: approx. 10 m (32.81 ft.)	
Dimensions	Approx. 229 W × 232 H × 112 D mm (approx. 9.02 W × 9.13 H × 4.41 D in.)	Approx. 160 W × 112 H × 50 D mm (approx. 6.30 W × 4.41 H × 1.97 D in.)	Approx. 139 W × 120 H × 52 D mm (approx. 5.47 W × 4.72 H × 2.05 D in.)	Approx. 160 W × 112 H × 50 D mm (approx. 6.30 W × 4.41 H × 1.97 D in.)	
Weight	CT6877A: approx. 5 kg (176.4 oz.) CT6877A-1: approx. 5.3 kg (187.0 oz.)	CT6876A: approx. 0.97 kg (34.2 oz.) CT6876A-1: approx. 1.3 kg (45.9 oz.)	CT6904A: approx. 1.05 kg (37.0 oz.) CT6904A-1: approx. 1.35 kg (47.6 oz.)	CT6875A: approx. 0.8 kg (28.2 oz.) CT6875A-1: approx. 1.1 kg (38.8 oz.)	

*1: ± (% of reading + % of range) , range is PW4001 *2: ± (% of reading + % of full scale) , full scale is rated current of sensor *3: Non-condensing
*4: When 1 kHz < f ≤ 700 kHz (CT6877A-1), 1 kHz < f ≤ 1 MHz (CT6876A-1/CT6875A-1), add ± (0.005 × f [kHz])% of reading to amplitude accuracy *5: When 50 kHz < f ≤ 1 MHz (CT6904A-3, CT6904A-1), add ± (0.015 × f)% of reading to amplitude accuracy

High-accuracy pass-through current sensors

Product warranty period: 3 year Guaranteed accuracy period: 1 year

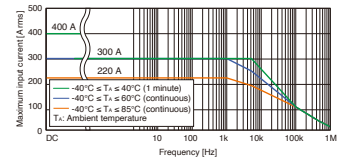
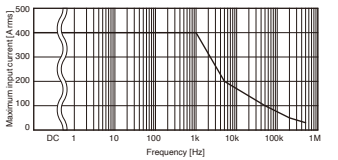
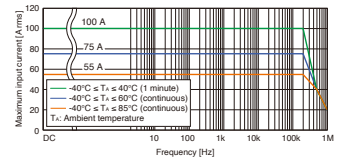
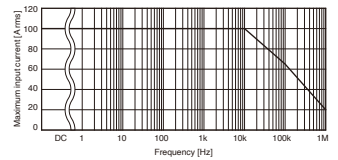
Model	CT6873, CT6873-01	CT6863-05	CT6872, CT6872-01	CT6862-05
Appearance				
Rated current	200 A AC/DC	200 A AC/DC	50 A AC/DC	50 A AC/DC
Frequency band	DC to 10 MHz	DC to 500 kHz	DC to 10 MHz	DC to 1 MHz
Diameter of measurable conductors	Max. φ 24 mm (0.94 in.)	Max. φ 24 mm (0.94 in.)	Max. φ 24 mm (0.94 in.)	Max. φ 24 mm (0.94 in.)
Accuracy	PW4001 Combined*1 Current (I) , Active power (P)		PW4001 accuracy + Sensor accuracy	
	Sensor only (amplitude)*2		Sensor only (amplitude)*2	
Common-Mode Rejection Ratio (CMRR) *3	150 dB or greater (DC to 1 kHz) 140 dB or greater (1 kHz to 10 kHz) 120 dB or greater (10 kHz to 100 kHz) 100 dB or greater (100 kHz to 1 MHz) (effect on output voltage and common mode voltage)		150 dB or greater (DC to 1 kHz) 140 dB or greater (1 kHz to 10 kHz) 120 dB or greater (10 kHz to 100 kHz) 100 dB or greater (100 kHz to 1 MHz) (effect on output voltage and common mode voltage)	
	0.05% f.s. or less (1000 V rms, DC to 100 Hz)		0.05% f.s. or less (1000 V rms, DC to 100 Hz)	
Linearity errors (typical)	± 2 ppm	-	± 2 ppm	-
Offset errors (typical)	± 5 ppm	-	± 5 ppm	-
Amplitude errors (typical)	(DC) ± 7 ppm, (10 to 500 Hz) ± 0.005%, (500 Hz-3 kHz) ± 0.01%, (3 k to 30 kHz) ± 0.1%, (30 k to 100 kHz) ± 0.4%, (100 k to 400 kHz) ± 1%, (400 kHz to 1 MHz) ± 3%	-	(DC) ± 7 ppm, (10 to 100 Hz) ± 0.005%, (100 Hz to 1 kHz) ± 0.01%, (1 k to 50 kHz) ± 0.1%, (50 k to 100 kHz) ± 0.3%, (100 k to 300 kHz) ± 1%, (300 kHz to 1 MHz) ± 3%	-
Frequency derating				
Output voltage	10 mV/A (= 2 V/200 A)	10 mV/A (= 2 V/200 A)	40 mV/A (= 2 V/50 A)	40 mV/A (= 2 V/50 A)
Operating temperature and humidity*4	-40° C to 85° C (-40° F to 185° F), 80% RH or less	-30° C to 85° C (-22° F to 185° F), 80% RH or less	-40° C to 85° C (-40° F to 185° F), 80% RH or less	-30° C to 85° C (-22° F to 185° F), 80% RH or less
Storage temperature and humidity*4	-40° C to 85° C (-40° F to 185° F), 80% RH or less	-30° C to 85° C (-22° F to 185° F), 80% RH or less	-40° C to 85° C (-40° F to 185° F), 80% RH or less	-30° C to 85° C (-22° F to 185° F), 80% RH or less
Maximum rated voltage to earth	1000 V CATIII anticipated transient overvoltage: 8000 V	1000 V AC/DC CATIII (50/60 Hz) anticipated transient overvoltage: 8000 V	1000 V CATIII anticipated transient overvoltage: 8000 V	1000 V AC/DC CAT III (50/60 Hz) anticipated transient overvoltage: 8000 V
Standards	Safety: EN 61010, EMC: EN 61326	Safety: EN 61010, EMC: EN 61326	Safety: EN 61010, EMC: EN 61326	Safety: EN 61010, EMC: EN 61326
Cable length	CT6873: approx. 3 m (9.84 ft.) CT6873-01: approx. 10 m (32.81 ft.)	Approx. 3 m (9.84 ft.)	CT6872: approx. 3 m (9.84 ft.) CT6872-01: approx. 10 m (32.81 ft.)	Approx. 3 m (9.84 ft.)
Dimensions	Approx. 70 W × 110 H × 53 D mm (approx. 2.76 W × 4.33 H × 2.09 D in.)	Approx. 70 W × 100 H × 53 D mm (approx. 2.76 W × 3.94 H × 2.09 D in.)	Approx. 70 W × 110 H × 53 D mm (approx. 2.76 W × 4.33 H × 2.09 D in.)	Approx. 70 W × 100 H × 53 D mm (approx. 2.76 W × 3.94 H × 2.09 D in.)
Weight	CT6873: approx. 370 g (13.1 oz.) CT6873-01: approx. 690 g (24.3 oz.)	Approx. 350 g (12.3 oz.)	CT6872: approx. 370 g (13.1 oz.) CT6872-01: approx. 690 g (24.3 oz.)	Approx. 340 g (12.0 oz.)

*1: ± (% of reading + % of range) , range is PW4001 *2: ± (% of reading + % of full scale) , full scale is rated current of sensor *3: Figures for CT6862-05 and CT6863-05 reflect effects of common-mode voltage. *4: Non-condensing

General use clamp sensor

Product warranty period: 3 year Guaranteed accuracy period: 1 year

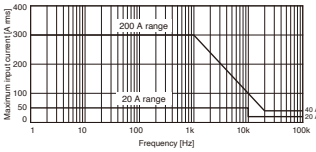
Model	9272-05																						
Appearance																							
Rated current	20 A AC, 200 A AC (2 range)																						
Frequency band	1 Hz ~ 100 kHz																						
Diameter of measurable conductors	φ 46 mm or less																						
Accuracy (amplitude) ± (% of reading + % of full scale)	<table border="1"> <tr><td>1 Hz ≤ f < 5 Hz</td><td>: ± 2.0% ± 0.10%</td></tr> <tr><td>5 Hz ≤ f < 10 Hz</td><td>: ± 1.0% ± 0.05%</td></tr> <tr><td>10 Hz ≤ f < 45 Hz</td><td>: ± 0.5% ± 0.02%</td></tr> <tr><td>45 Hz ≤ f ≤ 66 Hz</td><td>: ± 0.3% ± 0.01%</td></tr> <tr><td>66 Hz < f ≤ 500 Hz</td><td>: ± 0.5% ± 0.02%</td></tr> <tr><td>500 Hz < f ≤ 1 kHz</td><td>: ± 0.5% ± 0.02%</td></tr> <tr><td>1 kHz < f ≤ 5 kHz</td><td>: ± 1.0% ± 0.05%</td></tr> <tr><td>5 kHz < f ≤ 10 kHz</td><td>: ± 2.5% ± 0.10%</td></tr> <tr><td>10 kHz < f ≤ 20 kHz</td><td>: ± 5% ± 0.1%</td></tr> <tr><td>20 kHz < f ≤ 50 kHz</td><td>: ± 5% ± 0.1%</td></tr> <tr><td>50 kHz < f ≤ 100 kHz</td><td>: ± 30% ± 0.1%</td></tr> </table>	1 Hz ≤ f < 5 Hz	: ± 2.0% ± 0.10%	5 Hz ≤ f < 10 Hz	: ± 1.0% ± 0.05%	10 Hz ≤ f < 45 Hz	: ± 0.5% ± 0.02%	45 Hz ≤ f ≤ 66 Hz	: ± 0.3% ± 0.01%	66 Hz < f ≤ 500 Hz	: ± 0.5% ± 0.02%	500 Hz < f ≤ 1 kHz	: ± 0.5% ± 0.02%	1 kHz < f ≤ 5 kHz	: ± 1.0% ± 0.05%	5 kHz < f ≤ 10 kHz	: ± 2.5% ± 0.10%	10 kHz < f ≤ 20 kHz	: ± 5% ± 0.1%	20 kHz < f ≤ 50 kHz	: ± 5% ± 0.1%	50 kHz < f ≤ 100 kHz	: ± 30% ± 0.1%
1 Hz ≤ f < 5 Hz	: ± 2.0% ± 0.10%																						
5 Hz ≤ f < 10 Hz	: ± 1.0% ± 0.05%																						
10 Hz ≤ f < 45 Hz	: ± 0.5% ± 0.02%																						
45 Hz ≤ f ≤ 66 Hz	: ± 0.3% ± 0.01%																						
66 Hz < f ≤ 500 Hz	: ± 0.5% ± 0.02%																						
500 Hz < f ≤ 1 kHz	: ± 0.5% ± 0.02%																						
1 kHz < f ≤ 5 kHz	: ± 1.0% ± 0.05%																						
5 kHz < f ≤ 10 kHz	: ± 2.5% ± 0.10%																						
10 kHz < f ≤ 20 kHz	: ± 5% ± 0.1%																						
20 kHz < f ≤ 50 kHz	: ± 5% ± 0.1%																						
50 kHz < f ≤ 100 kHz	: ± 30% ± 0.1%																						
Frequency derating																							
Output voltage	20 A range: 100 mV/A (= 2 V/20 A) 200 A range: 10 mV/A (= 2 V/200 A)																						
Operating temperature and humidity ¹	0° C to 50° C (32° F to 122° F), 80% RH or less																						
Storage temperature and humidity ¹	-10° C to 60° C (14° F to 140° F), 80% RH or less																						
Withstand voltage	AC 600 V CATIII (50/60 Hz) anticipated transient overvoltage: 6000 V																						
Standards	Safety: EN 61010, EMC: EN 61326 Class A																						
Cable length	Approx. 3 m (9.84 ft.)																						
Dimensions	Approx. 78 W × 188 H × 35 D mm (approx. 3.07 W × 7.40 H × 1.38 D in.)																						
Weight	Approx. 450 g (15.9 oz.)																						

*1: Non-condensing

Direct-wiring type high-accuracy current sensors

Product warranty period: 3 year Guaranteed accuracy period: 1 year

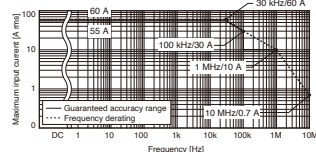
Model	PW9100A-3, PW9100A-4																																	
Appearance																																		
Rated current	50 A AC/DC																																	
Frequency band	DC to 3.5 MHz																																	
Measurement terminals	Isolated input, DCCT input Terminal block (with safety cover), M6 screws																																	
Accuracy	<table border="1"> <tr><td>PW4001 Combined¹</td><td>DC</td><td>: ± 0.05% ± 0.017%</td></tr> <tr><td>Current (I) , Active power (P)</td><td>45 Hz ≤ f ≤ 66 Hz</td><td>: ± 0.05% ± 0.015%</td></tr> <tr><td rowspan="12">Sensor only (amplitude)²</td><td>DC</td><td>: ± 0.02% ± 0.007%</td></tr> <tr><td>DC < f < 30 Hz</td><td>: ± 0.1% ± 0.02%</td></tr> <tr><td>30 Hz ≤ f < 45 Hz</td><td>: ± 0.1% ± 0.02%</td></tr> <tr><td>45 Hz ≤ f ≤ 65 Hz</td><td>: ± 0.02% ± 0.005%</td></tr> <tr><td>65 Hz < f ≤ 500 Hz</td><td>: ± 0.1% ± 0.01%</td></tr> <tr><td>500 Hz < f ≤ 1 kHz</td><td>: ± 0.1% ± 0.01%</td></tr> <tr><td>1 kHz < f ≤ 5 kHz</td><td>: ± 0.5% ± 0.02%</td></tr> <tr><td>5 kHz < f ≤ 20 kHz</td><td>: ± 1% ± 0.02%</td></tr> <tr><td>20 kHz < f ≤ 50 kHz</td><td>: ± 1% ± 0.02%</td></tr> <tr><td>50 kHz < f ≤ 100 kHz</td><td>: ± 2% ± 0.05%</td></tr> <tr><td>100 kHz < f ≤ 300 kHz</td><td>: ± 5% ± 0.05%</td></tr> <tr><td>300 kHz < f ≤ 700 kHz</td><td>: ± 5% ± 0.05%</td></tr> <tr><td>700 kHz < f ≤ 1 MHz</td><td>: ± 10% ± 0.05%</td></tr> </table>	PW4001 Combined ¹	DC	: ± 0.05% ± 0.017%	Current (I) , Active power (P)	45 Hz ≤ f ≤ 66 Hz	: ± 0.05% ± 0.015%	Sensor only (amplitude) ²	DC	: ± 0.02% ± 0.007%	DC < f < 30 Hz	: ± 0.1% ± 0.02%	30 Hz ≤ f < 45 Hz	: ± 0.1% ± 0.02%	45 Hz ≤ f ≤ 65 Hz	: ± 0.02% ± 0.005%	65 Hz < f ≤ 500 Hz	: ± 0.1% ± 0.01%	500 Hz < f ≤ 1 kHz	: ± 0.1% ± 0.01%	1 kHz < f ≤ 5 kHz	: ± 0.5% ± 0.02%	5 kHz < f ≤ 20 kHz	: ± 1% ± 0.02%	20 kHz < f ≤ 50 kHz	: ± 1% ± 0.02%	50 kHz < f ≤ 100 kHz	: ± 2% ± 0.05%	100 kHz < f ≤ 300 kHz	: ± 5% ± 0.05%	300 kHz < f ≤ 700 kHz	: ± 5% ± 0.05%	700 kHz < f ≤ 1 MHz	: ± 10% ± 0.05%
PW4001 Combined ¹	DC	: ± 0.05% ± 0.017%																																
Current (I) , Active power (P)	45 Hz ≤ f ≤ 66 Hz	: ± 0.05% ± 0.015%																																
Sensor only (amplitude) ²	DC	: ± 0.02% ± 0.007%																																
	DC < f < 30 Hz	: ± 0.1% ± 0.02%																																
	30 Hz ≤ f < 45 Hz	: ± 0.1% ± 0.02%																																
	45 Hz ≤ f ≤ 65 Hz	: ± 0.02% ± 0.005%																																
	65 Hz < f ≤ 500 Hz	: ± 0.1% ± 0.01%																																
	500 Hz < f ≤ 1 kHz	: ± 0.1% ± 0.01%																																
	1 kHz < f ≤ 5 kHz	: ± 0.5% ± 0.02%																																
	5 kHz < f ≤ 20 kHz	: ± 1% ± 0.02%																																
	20 kHz < f ≤ 50 kHz	: ± 1% ± 0.02%																																
	50 kHz < f ≤ 100 kHz	: ± 2% ± 0.05%																																
	100 kHz < f ≤ 300 kHz	: ± 5% ± 0.05%																																
	300 kHz < f ≤ 700 kHz	: ± 5% ± 0.05%																																
700 kHz < f ≤ 1 MHz	: ± 10% ± 0.05%																																	
Effects of common mode voltage	120 dB or greater (50/60 Hz, 100 kHz) (effect on output voltage and common mode voltage)																																	
Frequency derating																																		
Output voltage	40 mV/A (= 2 V/50 A)																																	
Operating temperature and humidity ³	0° C to 40° C (32° F to 104° F), 80% RH or less																																	
Storage temperature and humidity ³	-10° C to 50° C (14° F to 122° F), 80% RH or less																																	
Withstand voltage	600 V CATIII, 1000 V CATII anticipated transient overvoltage: 6000 V																																	
Standards	Safety: EN 61010, EMC: EN 61326 Class A																																	
Cable length	Approx. 0.8 m (2.62 ft.)																																	
Dimensions	Approx. 430 W × 88 H × 260 D mm (approx. 16.9 W × 3.46 H × 10.23 D in.)																																	
Weight	PW9100A-3: approx. 3.7 kg (130.5 oz.) PW9100A-4: approx. 4.3 kg (151.7 oz.)																																	

*1: ± (% of reading + % of range) , range is PW4001

*2: ± (% of reading + % of full scale) , full scale is rated current of sensor

*3: Non-condensing

PW4001

Measure Large Currents of up to 8000 A

The Sensor Unit CT9557 adds and outputs current sensor output from multi-wire lines. With the PW4001, the CT9557 can be used to accurately measure large currents of up to 8000 A (on a 4-wire line).

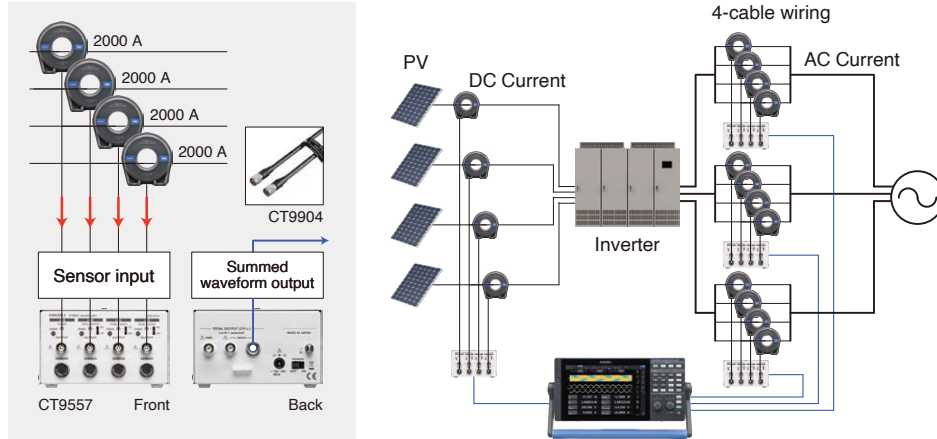

CT9557 specifications

Connectable current sensor	Current sensors are listed on p.19 - p.23	Wiring	Current	Using sensors
Summed waveform output accuracy ± (% of reading + % of full scale)	DC : ± 0.06% ± 0.03%	Single-cable or bundled wiring	1000 A	CT6876A/ CT6846A
	to 1 kHz : ± 0.06% ± 0.03%			
	to 10 kHz : ± 0.10% ± 0.03%	2-cable wiring	2000 A	CT6877A/ CT6847A
	to 100 kHz : ± 0.20% ± 0.10%			
	to 300 kHz : ± 1.0% ± 0.20%			
to 700 kHz : ± 5.0% ± 0.20%	3-cable wiring	3000 A	CT9557+CT6876A×3/ CT9557+CT6847A×3	
to 1 MHz : ± 10.0% ± 0.50%				
Operating temperature and humidity	-10° C to 50° C (14° F to 122° F), 80% RH or less	4-cable wiring	4000 A	CT9557+CT6876A×4/ CT9557+CT6846A×4
Power supply	100 V to 240 V AC (50 Hz/60 Hz)		6000 A	CT9557+CT6877A×3/ CT9557+CT6847A×3
Output connector	HIOKI ME15W (male connector)		8000 A	CT9557+CT6877A×4
Dimensions (W x H x D)	Approx. 116 × 67 × 132 mm (approx. 4.57. × 2.64. × 5.20 in.)			
Weight	Approx. 420 g (14.8 oz.)			
Included accessories	AC ADAPTER Z1002, Power cord			



SENSOR UNIT CT9557



Option CONNECTION CABLE CT9904
Cable length: 1 m (3.28 ft)
CT9904 required to connect to PW4001.

Measure High Voltages of up to 5000 V

The AC/DC High Voltage Divider VT1005 divides and outputs voltages of up to 5000 V. With the PW4001, the VT1005 can accurately measure high voltages of up to 5000 V.

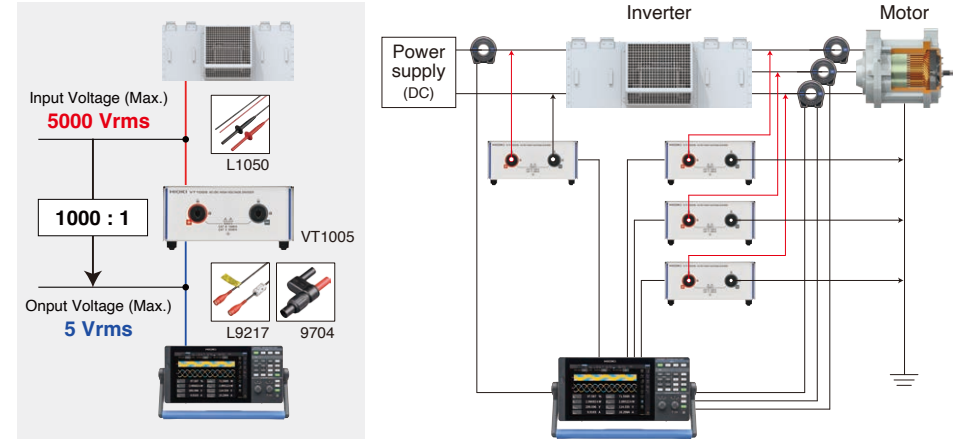

VT1005 specifications

Maximum rated voltage	5000 V rms, ± 7100 V peak (Provided this falls within the frequency derating curve illustrated)
Maximum rated voltage (line-to-ground)	No measurement category: 5000 V AC/DC (7100 V peak, Anticipated transient overvoltage 0 V) Measurement category II: 2000 V AC/DC (Anticipated transient overvoltage 12000 V) Measurement category III: 1500 V AC/DC (Anticipated transient overvoltage 10000 V)
Measurement accuracy	± 0.08% (DC), ± 0.04% (50 Hz/60 Hz), ± 0.17% (50 kHz)
Frequency flatness	Band where amplitude falls within ± 0.1% range: 200 kHz (typical) Band where phase falls within ± 0.1° range: 500 kHz (typical) ⁽⁵⁾
Measurement bandwidth	DC to 4 MHz (Amplitude and phase accuracy specified up to 1 MHz)
Voltage dividing ratio	1000 : 1
Common-mode voltage rejection ratio (CMRR)	50 Hz/60 Hz: 90 dB (typical), 100 kHz: 80 dB (typical)
Operating temperature and humidity range	-10° C to 50° C (14° F to 122° F), 80% RH or less (non-condensing)
Power supply	100 V to 240 V AC (50/60 Hz)
Dimensions (W x H x D)	Approx. 195.0 × 83.2 × 346.0 mm (approx. 7.68 × 3.28 × 13.62 in.)
Weight	Approx. 2.2 kg (77.6 oz.)
Measurement method	Differential input
Included accessories	- L1050-01 Voltage Cord (1.6 m/5.25 ft) - L9217 Connection Cord (insulated BNC, 1.6 m/ 5.25 ft) - 9704 Conversion Adapter (insulated-female BNC-to-banana plug) - Power cord



AC/DC HIGH VOLTAGE DIVIDER VT1005

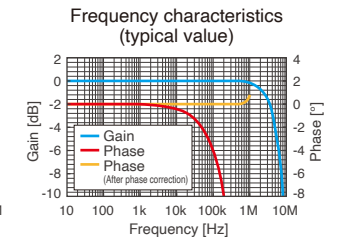
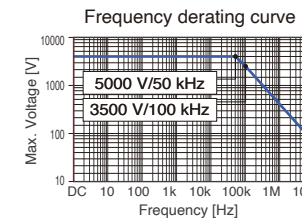

PW4001

Model: POWER ANALYZER PW4001

Model No. (Order Code)	Waveform and D/A output	Motor analysis	DC power supply drive (10.5 V to 28 V DC)
PW4001-01	—	—	—
PW4001-02	✓	—	—
PW4001-03	—	✓	—
PW4001-04	—	—	✓
PW4001-05	✓	✓	✓
PW9006-01	IEC Harmonic/Flicker Measurement (option)		



Accessories: Startup guide × 1, power cord × 1, USB cable × 1, D-sub 25-pin connector × 1, DC power supply connector (PW4001-04, -05)

- The separately sold voltage cords and current sensors are required for taking measurements.
- Please note that Waveform and D/A output, Motor analysis, and DC power supply drive cannot be added later.

Current measurement options (High accuracy: clamp type)

Model No. (Order Code)	Model	Rated Current	Frequency band	Cable length
CT6834	AC/DC CURRENT PROBE	500 A rms	DC to 50 kHz	5 m
CT6834-01	AC/DC CURRENT PROBE	500 A rms	DC to 50 kHz	10 m
CT6833	AC/DC CURRENT PROBE	200 A rms	DC to 50 kHz	5 m
CT6833-01	AC/DC CURRENT PROBE	200 A rms	DC to 50 kHz	10 m
CT6831	AC/DC CURRENT PROBE	20 A rms	DC to 100 kHz	4.2 m
CT6830	AC/DC CURRENT PROBE	2 A rms	DC to 100 kHz	4.2 m
CT6847A	AC/DC CURRENT PROBE	2000 A DC, 1400 A AC rms	DC to 70 kHz	3 m
CT6846A	AC/DC CURRENT PROBE	1000 A rms	DC to 100 kHz	3 m
CT6845A	AC/DC CURRENT PROBE	500 A rms	DC to 200 kHz	3 m
CT6844A	AC/DC CURRENT PROBE	500 A rms	DC to 500 kHz	3 m
CT6843A	AC/DC CURRENT PROBE	200 A rms	DC to 700 kHz	3 m
CT6841A	AC/DC CURRENT PROBE	20 A rms	DC to 2 MHz	3 m
9272-50	CLAMP ON SENSOR	AC 20 A/200 A rms	DC to 100 kHz	3 m

Current measurement options (High accuracy: pass-through, direct connection type)

Model No. (Order Code)	Model	Rated Current	Frequency band	Cable length or number of channels
CT6877A	AC/DC CURRENT SENSOR	2000 A rms	DC to 1 MHz	3 m
CT6877A-1	AC/DC CURRENT SENSOR	2000 A rms	DC to 1MHz	10 m
CT6876A	AC/DC CURRENT SENSOR	1000 A rms	DC to 1.5 MHz	3 m
CT6876A-1	AC/DC CURRENT SENSOR	1000 A rms	DC to 1.2 MHz	10 m
CT6904A	AC/DC CURRENT SENSOR	500 A rms	DC to 4 MHz	3 m
CT6875A	AC/DC CURRENT SENSOR	500 A rms	DC to 2 MHz	3 m
CT6875A-1	AC/DC CURRENT SENSOR	500 A rms	DC to 1.5 MHz	10 m
CT6873	AC/DC CURRENT SENSOR	200 A rms	DC to 10 MHz	3 m
CT6873-01	AC/DC CURRENT SENSOR	200 A rms	DC to 10 MHz	10 m
CT6863-05	AC/DC CURRENT SENSOR	200 A rms	DC to 500 kHz	3 m
CT6872	AC/DC CURRENT SENSOR	50 A rms	DC to 10 MHz	3 m
CT6872-01	AC/DC CURRENT SENSOR	50 A rms	DC to 10 MHz	10 m
CT6862-05	AC/DC CURRENT SENSOR	50 A rms	DC to 1 MHz	3 m
PW9100A-3	AC/DC CURRENT BOX	50 A rms	DC to 3.5 MHz	3 ch
PW9100A-4	AC/DC CURRENT BOX	50 A rms	DC to 3.5 MHz	4 ch

Current measurement options (Standard Sensor)

Model No. (Order Code)	Model	Rated Current	Frequency band	cable length
CT7742**	AC/DC AUTO ZERO CURRENT SENSOR	2000 A rms	DC to 5 kHz	2.5 m
CT7642**	AC/DC CURRENT SENSOR	2000 A rms	DC to 10 kHz	2.5 m
CT7044**	AC FLEXIBLE CURRENT SENSOR (Φ100 mm(3.94 in.))	6000 A rms	10 Hz to 50 kHz	2.5 m
CT7045**	AC FLEXIBLE CURRENT SENSOR (Φ180 mm(7.09 in.))	6000 A rms	10 Hz to 50 kHz	2.5 m
CT7046**	AC FLEXIBLE CURRENT SENSOR (Φ254mm(10.00 in.))	6000 A rms	10 Hz to 50 kHz	2.5 m

** CONVERSION CABLE CT9920 is required to connect to the PW4001.

CONVERSION CABLE CT9920



Required to connect PW4001 to the current sensor with HIOKI PL14 on the output connector.

[Applicable products]
CT7742, CT7642, CT7044, CT7045, CT7046

CONVERSION CABLE CT9904



Cable length: 1 m (3.28 ft) Required to connect the summing waveform output terminal of CT9557 to PW4001.

[Applicable products]
CT9557

PW4001

Voltage measurement options

1	L1025	VOLTAGE CORD	1500 V DC CATII, 1 A, 1000 V CATIII, 1 A banana-banana (red, black, 1 each), alligator clip, approx. 3 m (9.84 ft.) length
2	L9438-50	VOLTAGE CORD	1000 V CATIII, 10 A, 600 V CATIV, 10 A banana-banana (red, black, 1 each), alligator clip, spiral tube, approx. 3 m (9.84 ft.) length
3	L1000	VOLTAGE CORD	1000 V CATIII, 10 A, 600 V CATIV, 10 A banana-banana (red, yellow, blue, gray, 1 each, black × 4), alligator clip, approx. 3 m (9.84 ft.) length
4	L9257	CONNECTION CORD	1000 V CATIII, 10 A, 600 V CATIV, 10 A banana-banana (red, black, 1 each), alligator clip, approx. 1.2 m (3.94 ft.) length
5	L1021-01	PATCH CORD	1000 V CATIII, 10 A, 600 V CATIV, 10 A for branching voltage input, banana branch to banana clip (red × 1), 0.5 m (1.64 ft.) length
6	L1021-02	PATCH CORD	1000 V CATIII, 10 A, 600 V CATIV, 10 A for branching voltage input, banana branch to banana clip (black × 1), 0.5 m (1.64 ft.) length
7	L9243	GRABBER CLIP	1000 V CATII, 1 A, (red, black, 1 each)
8	L4940	CONNECTION CORD	1000 V CATIII, 10 A, 600 V CATIV, 10 A banana-banana (red, black, 1 each), approx. 1.5 m (4.92 ft.) length
9	L4935	ALLIGATOR CLIP SET	1000 V CATIII, 10 A, 600 V CATIV, 10 A, (red, black, 1 each)
10	VT1005	AC/DC HIGH VOLTAGE DIVIDER	Voltage divider up to 5000 V and output to PW4001 Accessories: 9704, L1050-01(1.6m), L9217(1.6m)
11	L1050-01, -03	VOLTAGE CORD	For VT1005, 1.6 m (L1050-01), 3 m (L1050-03)
12	L9217-01, -02	CONNECTION CORD	For VT1005 connection, insulated BNC, CAT II 600 V, 0.2 A, CAT III 300 V, 0.2 A, 3.0 m(L9217-01), 10.0 m(L9217-02)

Connection options

13	L9217	CONNECTION CORD	For motor analysis input, insulated BNC, CAT II 600 V, 0.2 A, CAT III 300 V, 0.2 A, 1.6 m
14	9165	CONNECTION CABLE	For BNC synchronization, metal BNC by metal BNC, 1.5 m (4.92 ft.) length
15	9713-01	CAN CABLE	One end terminating in bare wires, 2 m (6.56 ft.) length
16	CT9902	EXTENSION CABLE	For extension of current sensor cable, ME15W-ME15W, 5 m (16.40 ft.) length
17	CT9557	SENSOR UNIT	Adds output waveforms from up to 4 current sensors to 1 channel and outputs it to the PW4001.
18	CT9904	CONNECTION CORD	Cable length 1 m; required in order to connect the CT9557's added waveform output terminal to the PW4001.

Others

19	SP7001-95	NON-CONTACT CAN SENSOR	Acquires CAN or CAN FD signals, simply by pinching probes over wire insulation. It connects to the CAN connector of the PW4001, supports CAN or CAN FD communication, and can be powered via a USB connector.
20	L3000	D/A OUTPUT CABLE	D-sub 25-pin by BNC (male) 20-channel conversion cable
21	Z5200	BNC TERMINAL BOX	D-sub 25-pin by BNC (female) 20-channel conversion box
22	C4001	CARRYING CASE	Hard-trunk type, with casters
23	Z5302	RACKMOUNT FITTINGS	For EIA standard rack
24	Z5303	RACKMOUNT FITTINGS	For JIS standard rack

