

HIOKI

MEMORY HiCORDER MR8848

NEW



Engineered for Extremes, Trusted for Precision

For evaluation testing and troubleshooting

Robust housing and long recording time for
reliable measurements



Precision You Can Rely On —Even in Harsh Conditions



Infrastructure such as electric power facilities, data center UPSs, and railroads must operate with stability and zero downtime. High-precision waveform recording with the Memory HiCorder is essential to ensure safe and reliable operation of critical infrastructure.

Reduced Risk of Failure

To minimize the risk of failure due to drops and shocks, the Memory HiCorder MR8848 employs a rugged housing with protectors for enhanced durability.



Record the Entire Phenomenon

Improve your troubleshooting by recording anomaly waveforms before and after the anomalies occur. Track everything from instantaneous fluctuations to long-term behavior by leveraging the HiCorder's long recording time and high-resolution.

Safe and Reliable Measurements

When inspecting lines of differing electrical systems simultaneously (e.g., power lines and signal wires), short-circuit are a serious risk. Unlike oscilloscopes, Memory HiCorders have isolated channels, so short-circuit accidents will not occur between differing circuits.



Correlation Analysis of Various Physical Phenomena

Troubleshooting and analysis can be more in depth than ever before through simultaneous recording of various physical phenomena. The Memory HiCorder MR8848 records and analyzes multiple physical parameters—including voltage, current, temperature, vibration, pressure, and strain—for identifying correlations and root causes.

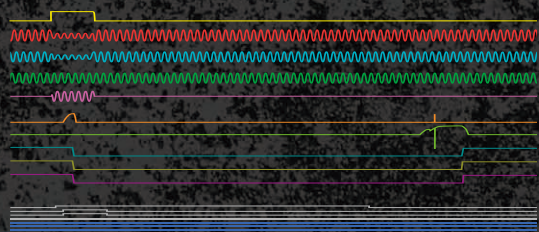

UPS Operation Test



Why It Matters

Blackouts (due to lightning strikes) and power anomalies (due to load fluctuations) to certain critical infrastructure can cause serious loss or harm. Uninterruptible power supplies (UPSs) make sure that power remains stable or uninterrupted when such anomalies occur. Examples of such facilities are data centers that handle critical data around the clock, hospitals that protect patients' lives, and manufacturing lines that require continuous operation.

Confirming Smooth Power Backups

Operation tests verify that UPSs reliably supply power in the event of a power failure, voltage drops, or other abnormalities. In this test, an abnormal condition is generated on the side of the regular power source (primary side). The HiCorder then records the voltage and current waveforms output by the UPS (secondary side) to the connected equipment and facilities. The time it takes for the UPS to supply power is determined and compared against standards and requirements. With the MR8848's multi-channel capability, both single-phase and three-phase UPS systems can be evaluated. High-speed sampling captures transient fluctuations with microsecond precision, ensuring accurate UPS behavior analysis.

Single-phase UPS evaluation

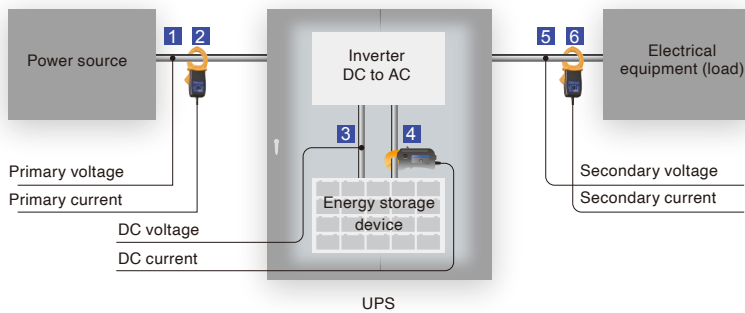

Measured phenomena on 6 or more channels

- Primary side: voltage 1 ch, current 1 ch
- Secondary side: voltage 1 ch, current 1 ch
- Energy storage device: voltage 1 ch, current 1 ch
- Temperature or other phenomena (channel number depends on measurement objects and module limitations)

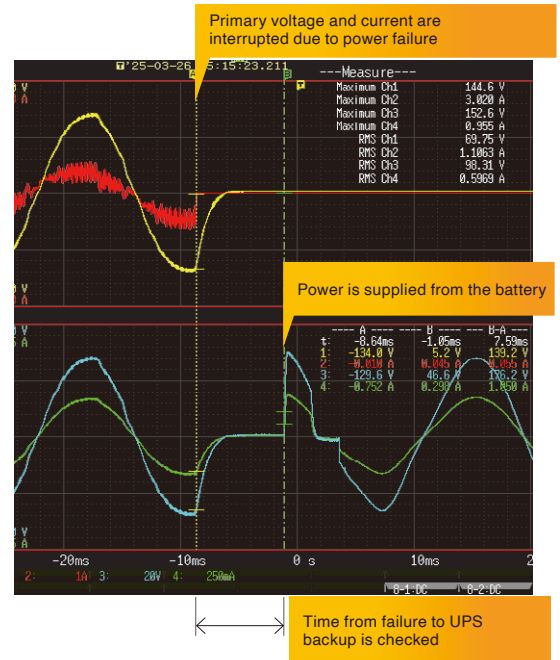

Further Analysis

In addition to power recording, further analysis can be simultaneously performed, such as temperature measurement of each component recorded to find abnormal heat generation. The Memory HiCorder MR8848 enables multi-parameter analysis—voltage, current, vibration, strain, and more—with advanced waveform calculation for maximum/minimum values, cycle evaluation, and time difference measurement.

Typical Configuration for This Application



MEMORY HiCORDER MR8848



Voltage measurement ANALOG UNIT 8966



Current measurement 3CH CURRENT UNIT U8977



Temperature measurement TEMP UNIT 8967



Current sensor AC/DC CURRENT PROBE CT6843A CLAMP ON SENSOR 9272-05

Load Rejection Test for Hydropower Generation



Ensuring Turbine Stability During Load Loss

Continuous power is critical for modern society, making periodic inspections for generators essential. For hydropower and other generators, load rejection tests are performed to ensure that turbines can safely shut down when load is suddenly lost. As the load decreases, the turbine speed increases. To control this, the regulating valve in the water channel must respond quickly.

Verifying Quick Load Rejection

Using a Memory HiCorder MR8848, operators can safely and thoroughly verify the turbine's quick response. Using the HiCorder, multiple signals can be simultaneously acquired, such as generated current, voltage waveforms, turbine speed, water pressure, and valve control signals. Rotation speed and water pressure are captured using external sensors that convert analog outputs into physical values. Because the MR8848 supports multi-parameter measurement, the generator's behavior can be analyzed from multiple angles. Its channel-to-channel isolation ensures safe data acquisition of different voltage signals, delivering highly reliable results in high-voltage systems.

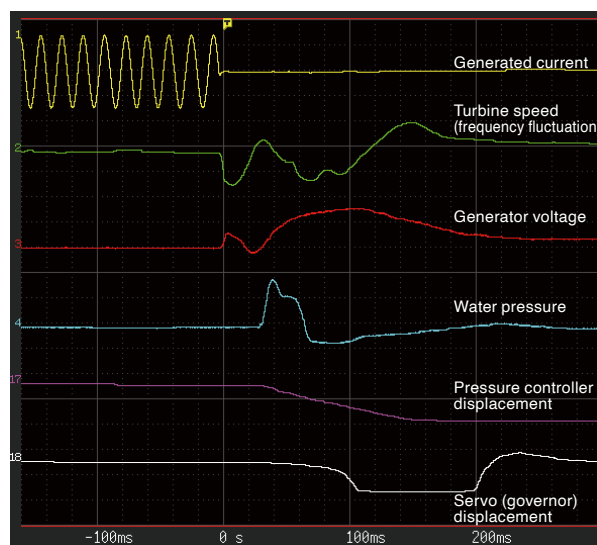
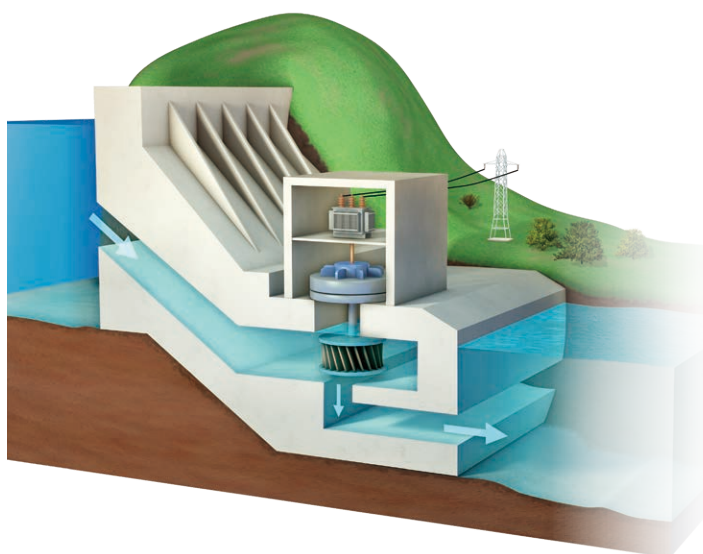

Test Sequence

When the load is interrupted, the generated current decreases and the turbine speed begins to increase. Upon detecting the load rejection, the valves in the water channels begin to close, and the operation until they are completely closed is recorded in detail. The MR8848 records the time, from turbine speed reduction to a complete stop, to ensure that the system is reliably controlled.

Main evaluation points

- Is each operation performed in sequence and quickly enough?
- Verification of values before load rejection, the maximum values after load rejection, and the rate of change for those values
- Verify whether the time to a complete stop conforms to safety standards

Typical Configuration for This Application



MEMORY HiCORDER MR8848



Voltage measurement ANALOG UNIT 8966 DIFFERENTIAL PROBE P9000-02 AC ADAPTER Z1008



Current measurement 3CH CURRENT UNIT U8977 CLAMP ON SENSOR 9272-05



Rotation speed/frequency FREQ UNIT 8970



Water pressure STRAIN UNIT U8969 Strain gauge type pressure sensor*

*Hioki does not manufacture/sell strain gauges. Please purchase separately.

High-Voltage Circuit Breaker Operation Test



Verifying Circuit Breaker Timing in Critical Systems

Electricity from power plants is transmitted at high voltage, stepped down by terminal equipment, then sent to end-users. In the event of a fault, high-voltage circuit breakers must rapidly interrupt power to prevent widespread damage.

In a three-phase system, the circuit breaker contains three ON/OFF contacts—one for each phase—that must operate simultaneously. However, slight timing differences often occur between phases due to variations in the spring-loaded mechanisms.

The Memory HiCorder MR8848 enables high-accuracy time difference analysis to verify whether all contacts operate within specified tolerances, ensuring safe and reliable circuit breaker performance.

Acquisition of Breaker Timing

In this test, the control current that starts the breaker's operation is used to trigger the HiCorder's recording. From there on, it records all other signals needed for the engineer to analyze the time it takes for each part to operate (e.g., each phase's response time from power abnormality).

Before the test, the engineer connects a current probe to the control current line and a logic probe to each side of the contact point for each phase's breaker (to detect the open/close state). As for the HiCorder settings, the control current is set as the trigger to start data acquisition for all other signals. This allows the engineer to evaluate whether switching delays exist and whether each contact's response falls within acceptable timing tolerances. Even subtle differences between lines U, V, and W are clearly visualized and analyzed.

Measurement circuit

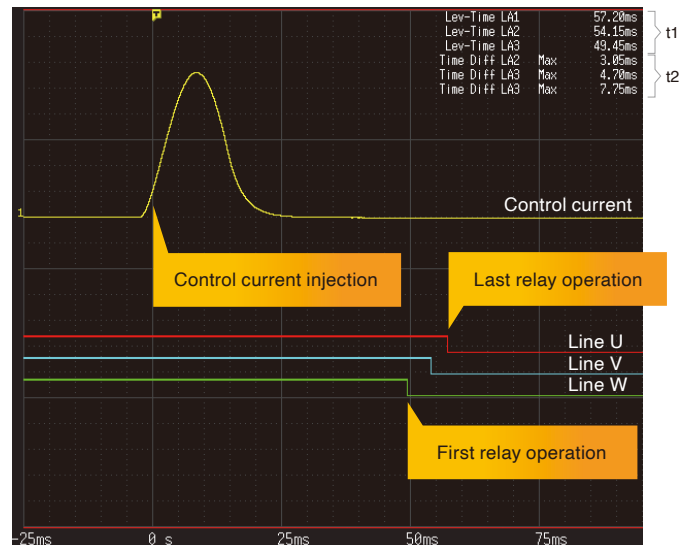
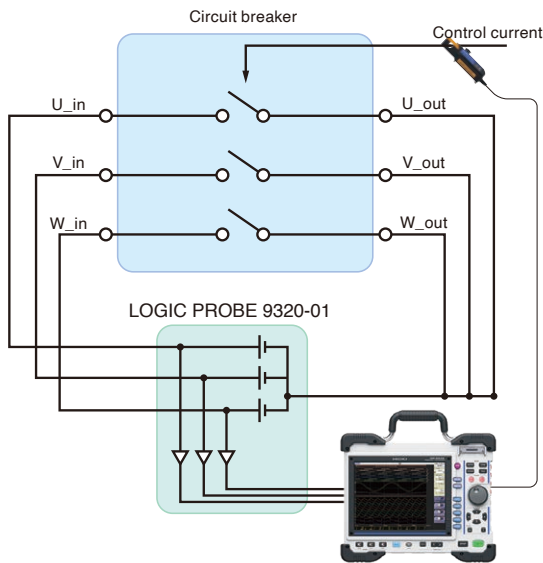

t1 < Specified time from control current injection to relay opening/closing
t2 < Specified time difference between each contact

Analysis

Automatic calculation of the time difference between command input and contact response for each phase is easy when using the MR8848's time difference function. Users can also define upper and lower limits to enable automatic pass/fail judgment, reducing total time spent on testing.

In addition, engineers can assess the frequency and duration of chattering by combining the time difference and pulse count functions. In this way, the engineer has a clear, comprehensive view of each contact's operational stability.

Typical Configuration for This Application



MEMORY HiCORDER
MR8848



Breaker contact ON/OFF
LOGIC PROBE 9320-01



Current measurement
3CH CURRENT UNIT U8977



Current sensor
AC/DC CURRENT PROBE
CT6830 or CT6831

* Since control currents are DC, the DC current probe specs must match the current's bandwidth and magnitude.
CT6830: Maximum 2 A ratio
CT6831: Maximum 20 A ratio

Analysis of Railway Vehicle Operation



Ensuring Safety and Efficiency

Rail vehicles must start, run, and stop safely under all operating conditions. To guarantee smooth operation, data must be recorded and analyzed to ensure each system such as the motor inverter and braking functions reliably. This is especially important for modern rail systems where operation is automated and coordinated across the rolling stock and signaling systems. Operation tests help verify that there are no anomalies in these systems, and that each component responds correctly during transportation.

Real-Driving Data to Find Correlations

In this test, the following parameters are simultaneously recorded while driving from the origin to the destination.

Voltage and current	The voltage and current flowing from the inverter to the motor are accurately recorded by high-speed sampling
Vehicle speed	Analog pulse signals are captured and converted to RPM
Brake pressure	A strain-gauge type pressure sensor is used
Vibration	XYZ-axis vibration is recorded to find abnormal vibration using a 3-axis accelerometer

Simultaneous recording of multiple phenomena (AC, DC, speed, etc.) and large memory storage capacity (up to 1 TB) makes the Memory HiCorder MR8848 ideal for this application. Furthermore, in-depth analysis is easy with its complex calculation of all recorded data of several tens of minutes, starting from the test's origin to destination.

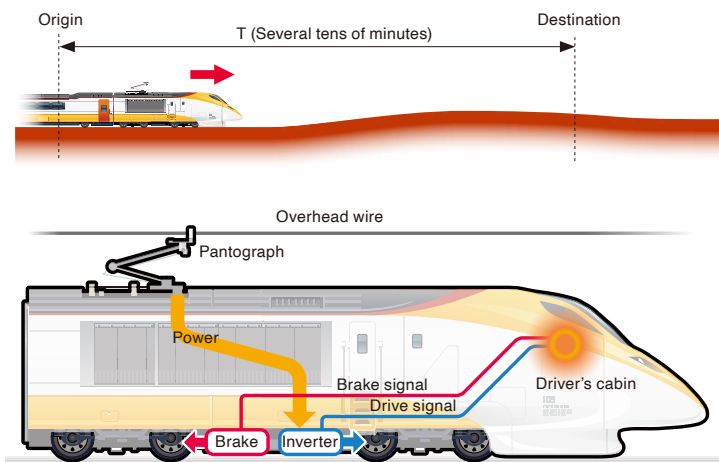

- Current and voltage of drive motor and inverter
- Vehicle speed, Brake pressure, and rotation speed

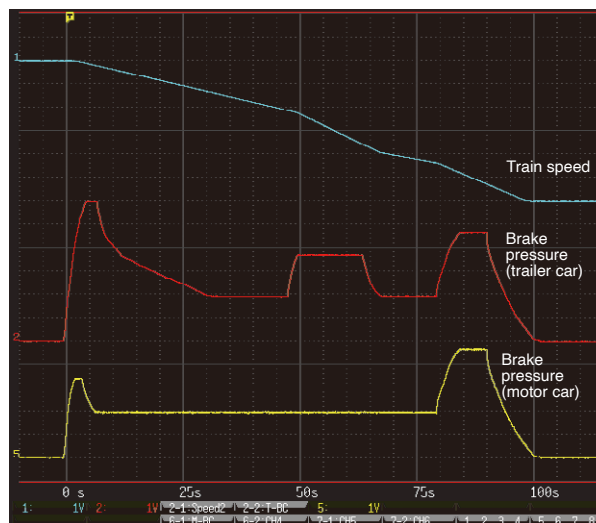

Appropriate brake pressure for the speed is analyzed with simultaneously recorded brake pressure and vehicle speed

Analysis

- Confirm optimal voltage and current levels
- Check brakes for appropriate brake pressure
- Comply with standards for time to full stop
- Find abnormal vibrations during operation

Typical Configuration for This Application



MEMORY HiCORDER MR8848



Voltage measurement ANALOG UNIT 8966
Differential probe 9000-02
AC Adapter Z1008



Current measurement 3CH CURRENT UNIT U8977
CLAMP ON SENSOR 9272-05

* Pressure sensors are not our products. They are shown as examples of use.



Rotation speed/frequency FREQ UNIT 8970



Brake pressure STRAIN UNIT 8969
Strain gauge type pressure sensor*

*The pressure sensor is not Hioki products. Please purchase separately.

Key Features

Record Long-Duration Waveform with High-Capacity Storage (additional function MR9001-01 and factory option U8334)



Long-term waveform recording becomes possible by storing data on the large-capacity 1 TB SSD (U8334) with the Direct Write to Storage option (MR9001). For example, in railway vehicle measurement, the HiCorder will record over 10 parameters at a sampling rate of 10 $\mu\text{s}/\text{S}$ for more than an hour.

X-Y Charting



Visualize the relationship between two parameters, such as torque and current, or pressure and flow rate, with X-Y charting.

Flexible Pass/Fail Area

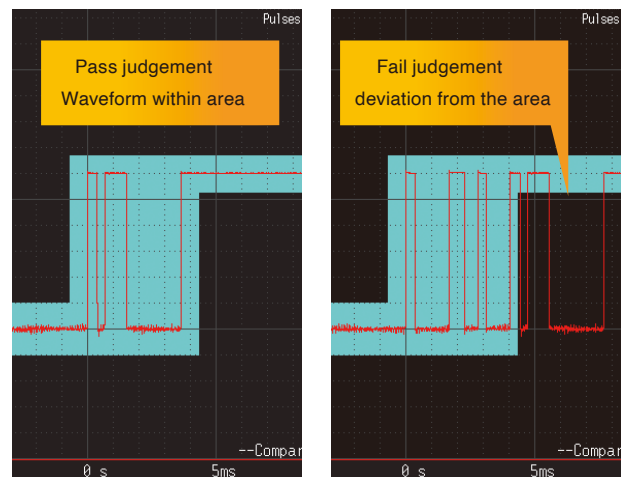

Automatically judge pass/fail of quality of welding, press stroke volume, equipment consistency, etc., by defining your own pass/fail area for waveforms.

Onsite, Tamper-Proof Printing (Factory Option U8351)

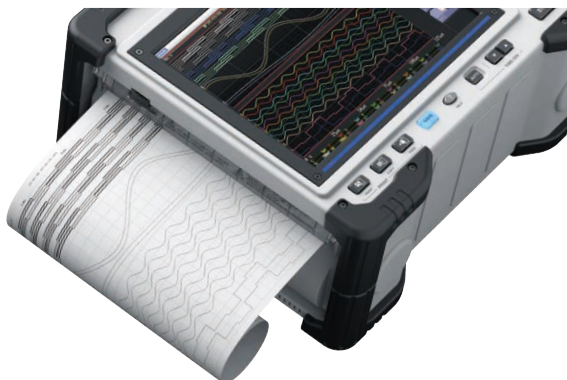

The factory-option printer lets you immediately print and share tamper-proof hard copies of your measurements right at the site, so that data cannot be tampered with.

Analyze on a PC

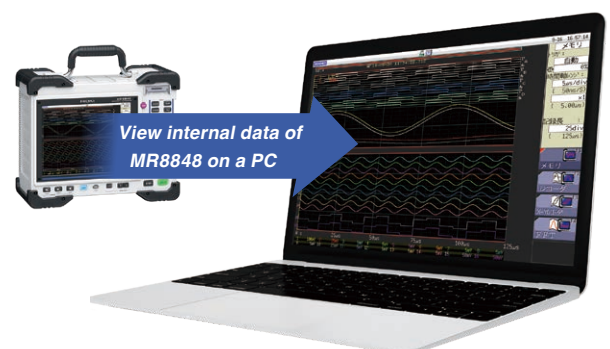

Analyze on a PC's LabView, MATLAB, or Hioki MR6000 Viewer software (data exported from MR6000 Viewer to LabView or MATLAB format).

MEMORY HiCORDER MR8848



Measurement units, storage media, voltage cables, current probes, etc., are not included. For details on accessories and factory options, please refer to the separate data sheet.

	Product name	Product number
Main unit	MEMORY HiCORDER	MR8848
Factory option	PRINTER UNIT	U8351
	INTERNAL STORAGE	U8334
	DC POWER UNIT	9784
Additional function	DIRECT WRITE TO STORAGE	MR9001-01

Specifications Overview

Measurement functions	Memory function (waveform recording), Recorder function (peak/trough recording), X-Y Recorder function, FFT function
Example channel configurations/numbers	Eight analog input modules: 16 analog channels + 16 logic channels (built-in) Eight 4ch analog input modules: 32 analog channels + 16 logic channels (built-in) Five analog input modules + three logic input modules: 10 analog channels + 64 logic channels (16 built-in channels + 48 channels in logic input modules) Five 4ch analog input modules + three logic input modules: 20 analog channels + 64 logic channels (16 built-in channels + 48 channels in logic input modules)
Module slots	Up to 8 modules Restrictions: Up to 4 modules of Model 8971 CURRENT UNIT Up to 3 modules of Model 8973 LOGIC PROBE Up to 3 modules of Model U8977 3CH CURRENT UNIT
Maximum sampling speed	20 MS/s for simultaneous use of all channels (when using ANALOG UNIT 8966) 10 MS/s for external sampling
Memory capacity	Total 512 megawords (no memory expansion) (16 megawords/ch using 32 analog channels, 256 megawords/ch using 2 analog channels)
External storage	SD card slot x 1, USB memory slot x 1, Internal storage (1 TB, factory option)
Printer	PRINTER UNIT U8351 (factory option)
Control terminals	External trigger input, trigger output, external sampling input, two external outputs (GO, NG), three external inputs (START, STOP, SAVE)
External interface	LAN: 1000BASE-T (FTP server, HTTP server) USB: USB 3.0 compliant, series A receptacle x 1, series B receptacle x 1
Environmental conditions (no condensation)	Operation: -10°C to 40°C (14°F to 104°F), 20% to 80% RH With printer in use: 0°C to 40°C (32°F to 104°F), 20% to 80% RH Storage: -20°C to 50°C (-4°F to 122°F), 90% RH or less
Power supply	100 V to 240 V AC, 50 Hz/60 Hz 10 V to 28 V DC (when using DC POWER UNIT 9784)
Power consumption	130 VA (220 VA when using PRINTER UNIT U8351)
Dimensions and weight	Approx. 351 mm (13.82 in.) W x 261 mm (10.28 in.) H x 140 mm (5.51 in.) D (excluding protrusions), 7.6 kg (268.1 oz., main unit only)
Included accessories	Startup guide x1, precautions for use x1, input code label x1, power cord x1 (RECORDING PAPER x1 and roll paper attachment x2, when PRINTER UNIT U8351 is installed)

Optional Units

Product number	Object of measurement	Number of channels	Maximum sampling speed	Maximum input
ANALOG UNIT 8966	Voltage	2 ch	20 MS/s	400 V DC
4CH ANALOG UNIT U8975	Voltage	4 ch	5 MS/s	200 V DC
4CH ANALOG UNIT U8978	Voltage (high resolution)	4 ch	5 MS/s	40 V DC
HIGH RESOLUTION UNIT 8968	Voltage (high resolution)	2 ch	1 MS/s	400 V DC
DC/RMS UNIT 8972	Voltage (DC, RMS)	2 ch	1 MS/s	400 V DC
HIGH VOLTAGE UNIT U8974	Voltage (high voltage)	2 ch	1 MS/s	1000 V DC, 700 V AC
DIGITAL VOLTMETER UNIT MR8990	Voltage (ultra-high resolution)	2 ch	2 ms	500 V DC
3CH CURRENT UNIT U8977	Current	3 ch	5 MS/s	Current sensor input only
CURRENT UNIT 8971	Current			Current sensor input only
TEMP UNIT 8967	Temperature	2 ch	1.2 ms	Thermocouple input only
STRAIN UNIT U8969	Strain	2 ch	200 kS/s	Strain input only
FREQ UNIT 8970	Waveform frequency	2 ch	200 kS/s	400 V DC
CHARGE UNIT U8979	Acceleration	2 ch	200 kS/s	40 V DC
LOGIC UNIT 8973	Logic signal	4 probe terminals		
WAVEFORM GENERATOR UNIT MR8790	Waveform generation	4 ch		
ARBITRARY WAVEFORM GENERATOR UNIT U8793	Waveform generation	2 ch		
PULSE GENERATOR UNIT MR8791	Pulse generation	8 ch		

Maximum Recording Time (Memory Function, Saving to Internal Memory)

Time axis*	Sampling cycle	Sampling speed	Maximum recording time for example channel configurations		
			32 ch analog + 16 ch built-in logic	16 ch analog + 16 ch built-in logic	4 ch analog + 16 ch built-in logic
5 μ s/div	50 ns	20 MS/s	Unavailable	1.6 s	6.4 s
10 μ s/div	100 ns	10 MS/s	1.6 s	3.2 s	12.8 s
20 μ s/div	200 ns	5 MS/s	3.2 s	6.4 s	25.6 s
100 μ s/div	1 μ s	1 MS/s	16.0 s	32.0 s	2 min 8 s
200 μ s/div	2 μ s	500 kS/s	32.0 s	1 min 4 s	4 min 16 s
1 ms/div	10 μ s	100 kS/s	2 min 40 s	5 min 20 s	21 min 20 s
10 ms/div	100 μ s	10 kS/s	26 min 40 s	53 min 20 s	3 h 33 min 20 s
100 ms/div	1 ms	1 kS/s	4 h 26 min 40 s	8 h 53 min 20 s	1 d 11 h 33 min 20 s

Maximum Recording Time (Memory Function, DIRECT WRITE TO STORAGE MR9001-01, Saving to INTERNAL STORAGE U8334)

Time axis*	Sampling cycle	Sampling speed	Maximum recording time for example channel number		
			32 ch analog	16 ch analog	4 ch analog
100 μ s/div	1 μ s	1 MS/s	-	-	8 min 56 s
200 μ s/div	2 μ s	500 kS/s	-	-	17 min 53 s
500 μ s/div	5 μ s	200 kS/s	-	-	44 min 44 s
1 ms/div	10 μ s	100 kS/s	1 h 29 min 28 s	1 h 29 min 28 s	1 h 29 min 28 s
5 ms/div	50 μ s	20 kS/s	7 h 27 min 23 s	7 h 27 min 23 s	7 h 27 min 23 s
10 ms/div	100 μ s	10 kS/s	14 h 54 min 47 s	14 h 54 min 47 s	14 h 54 min 47 s
50 ms/div	500 μ s	2 kS/s	3 d 2 h 33 min 55 s	3 d 2 h 33 min 55 s	3 d 2 h 33 min 55 s
100 ms/div	1 ms	1 kS/s	6 d 5 h 7 min 50 s	6 d 5 h 7 min 50 s	6 d 5 h 7 min 50 s

* The s/div (seconds per division) setting on the HiCorder defines the time scale of the horizontal axis, indicating how many seconds each grid division represents on the display.

Note: company names and product names appearing in this brochure are trademarks or registered trademarks of various companies.

HIOKI
HIOKI E. E. CORPORATION

HEADQUARTERS
81 Koizumi,
Ueda, Nagano 386-1192 Japan
<https://www.hioki.com/>



Scan for all regional contact information

DISTRIBUTED BY