

PW4001

HIOKI

PW4001-01
PW4001-02
PW4001-03
PW4001-04
PW4001-05

Instruction Manual

POWER ANALYZER



Check for the latest edition and other language versions.



**Read carefully before use.
Keep for future reference.**

Safety Information ▶ p.19

Measurement Procedure ▶ p.24

Part Names and Functions ▶ p.30

Maintenance and Service ▶ p.393

Troubleshooting ▶ p.395

Error Messages ▶ p.398

EN

June 2026 Revised edition 1
PW4001A961-01



Contents

Introduction	7	Wiring mode	67
Checking Package Contents	9	Current sensor auto-recognition function	67
Options (Sold Separately)	10	Compensating for phase errors of	
Symbols and Abbreviations	17	current sensors	68
Safety Information	19	2.6 Simple Configuration (Quick Set)	70
Precautions for Use	21	2.7 Measurement mode	72
Measurement Procedure	24	2.8 Zero Adjustment and Degaussing	
1 Overview	27	(Demagnetization)	74
1.1 Product Overview	27	2.9 Connecting Measurement Leads and	
1.2 Features	27	Sensors to Lines to Be Measured	75
1.3 Part Names and Functions	30	Wiring diagrams	76
1.4 Basic Operation (Screen Display and		2.10 Checking Connections	78
Layout)	37	3 Displaying Power Numerically	81
Screen operation	37	3.1 Displaying Measured Values	81
Common screen display	41	3.2 Measuring Power	84
Measurement screen	43	Displaying measured power values	84
Screen configurations	45	Displaying measured voltage or current	
1.5 System Architecture	48	values	85
1.6 Example Measurement Setups	49	Voltage range and current range	86
Evaluating the power conversion		Setting the zero suppress	88
efficiency of inverters	49	Data update interval	89
Evaluating the performance of EV and		Synchronization source	91
HEV inverter motors	49	Low-pass filter (LPF)	93
Evaluating the efficiency of PV power		Measurement upper frequency limit and	
conditioners (PCS)	50	lower frequency limit (configuring	
Vehicle fuel efficiency evaluation tests	50	frequency measuring range)	94
2 Preparing for measurement	51	Rectification method	96
2.1 Inspecting the Instrument before Use	52	Scaling (when using VTs [PTs] or CTs)	97
2.2 Connecting the Voltage Cords (Voltage		3.3 Integration Measurement	98
Input)	54	Displaying integrated measured values	99
2.3 Connecting the Current Sensors (Current		Integration mode	102
Input)	55	Integration measurement while using	
Connecting a CT7000 Series sensor	58	the time control function	104
If the input exceeds the measurable		3.4 Measuring Harmonics	106
range (using VTs and CTs)	59	Wideband measurement mode	106
2.4 Supplying Power to the Instrument	60	IEC measurement mode (PW9006	
When using a commercial power supply	60	option)	106
When using a DC power supply (DC		Displaying measured harmonic values	107
power supply option)	61	Configuring settings common to	
Turning the instrument on	64	harmonics	113
Turning the instrument off	65	3.5 Measuring efficiency and loss	116
2.5 Setting Wiring Mode and Configuring		Selecting the calculation method	116
Current Sensor Settings	66	[Fixed] mode	117
		[Auto] mode	119
		Displaying efficiency and loss	122

3.6	Motor Measurement (Motor Analysis-Equipped Model)	123	Δ -Y conversion	175
	Motor measurement wiring	123	Y- Δ conversion	177
	Connection examples of motor analysis	127	5.6 Power calculation method	179
	Displaying measured motor values	129	5.7 User-defined formula (UDF)	180
	Zero adjustment of motor input	131	Setting the user-defined formulas (UDF)	180
	Configuring the motor input settings	132	Saving user-defined formula (UDF) setting data	183
	Torque meter correction function	137	Loading user-defined formula (UDF) setting data	184
	Measuring the electric angle of the motor	139	5.8 Graph Display Function	185
	Detecting the motor's direction of rotation	142	Trend graph	185
3.7	Measuring IEC Voltage			
	Fluctuation/Flicker (PW9006 option)	144	6 System Settings	189
	Making the IEC flicker measurement settings	145	6.1 Checking and Changing Settings	189
	How to measure IEC flicker	146	6.2 Initializing the Instrument	193
	Description of measurement parameters	147	System reset	193
			Boot-key reset	193
			Touch panel calibration	194
			6.3 Factory Default Settings	195
4	Displaying Waveforms	149	7 Saving Data and Managing Files	199
4.1	Waveform Display Method	149	7.1 Internal memory	200
4.2	Changing the Waveform Display and Configuring Recording	152	7.2 USB flash drive	201
	Time axis setting	152	7.3 Data Save Destination	203
	Vertical axis zoom factor and display position settings	154	7.4 File Operation Screen	204
	Vertical axis zoom list display	155	7.5 Saving Measured Data	206
	Configuring the trigger settings	156	Settings which measurement parameters to save	207
4.3	Recording Waveforms	159	Manually saving measured data	210
4.4	Analyzing Displayed Waveforms	160	Automatically saving measured data	212
	Displaying measured values of waveforms (cursor measurement)	160	Recordable time and data	214
	Displaying enlarged views of waveforms (zoom function)	162	Auto-save operation using time control	216
			Data save interval other than OFF	216
			Timer control + Data save interval OFF	216
			Real time control + Data save interval OFF	216
			Timer control + Data save interval other than OFF	216
			Real time control + Data save interval other than OFF	217
			7.6 Saving Waveform Data	218
			7.7 Saving and Loading Screenshots	220
			7.8 Saving and Loading the Settings Data	223
			7.9 File and Folder Operation	225
			File and folder operation with a USB flash drive or the internal memory	225
			Formatting a USB flash drive or the internal memory	227
			Manual file transfer (uploading to an FTP server)	227
5	Various Functions	165		
5.1	Time Control Function	165		
	Timer control	165		
	Real time control	165		
	Time control function setting method	166		
5.2	Average Function	168		
	Average settings	169		
	Average operation	170		
	Behavior when an overload condition occurs	170		
5.3	Hold function	171		
	Operation in the hold state	172		
5.4	Peak hold function	173		
	Operation in the peak hold state	174		
5.5	Delta Conversion Function	175		

7.10	Measured Value Save Data Format	228	9.5	Sending Data Using the FTP Client Function	298
	Header structure	228		Setting automatic file upload	299
	Status data	234		Sending files manually	305
	Data format for measured values	237	9.6	FTP Server Mounting Function	306
7.11	BIN Saving Format	238		Settings for saving files on the FTP server	307
8	Connecting External Devices	239	9.7	Controlling the Instrument with Communications Commands	310
8.1	Synchronous Measurement	239		GENNECT One (PC Application Software)	311
	BNC synchronization	239	9.8	PW Data Receiver (PC Application Software)	312
8.2	Waveform/Analog Output (Waveform and D/A Output Option)	242	9.9	Controlling the Instrument and Acquiring Data Using Modbus/TCP Server Communications	315
	Connecting external devices	242		How to connect	315
	Selecting output parameters	245		Modbus specifications	315
	Output rates	248	9.10	Sending Measurement Data Via XCP on Ethernet	316
	Examples of D/A output	252		How to connect	316
8.3	Controlling Integration with External Signals	254		Settings on the client software for ECU measurement and calibration	316
8.4	CAN output function	257	10	Specifications	317
	Overview of the CAN output function	257	10.1	General Specifications	317
	CAN data output procedure	257	10.2	Specifications of Input, Output, and Measurement	319
	Setting CAN output	257		Basic specifications	319
	Creating a DBC file	262		Specifications of waveform recording	330
	Outputting CAN signals	264		Specifications of flicker measurement (PW9006 option)	331
8.5	Arbitrary Frame Output Function	266		Specifications of motor analysis (optional)	332
	Outputting arbitrary frames	268		Specifications of waveform and D/A output (optional)	336
8.6	CAN Input Function	269		Display specifications	337
	Overview of the CAN input function	269		Specifications of operating parts	337
	CAN data input procedure	269		External interface specifications	338
	CAN input settings	269	10.3	Function Specifications	345
	Overview of the diagnostic measurement setup	275		Auto-ranging	345
	Diagnostic measurement setup procedure	275		Time control	345
8.7	VT1005 AC/DC High Voltage Divider	281		Hold function	346
9	Connecting with Computers	283		Calculation function	347
9.1	USB Connections and Settings	285		Display function	352
	USB cable connections	285		Trend graph function	354
	Acquiring data in USB mass storage mode	285		Automatic data-saving function	354
	Exiting USB mass storage mode	287		Manual data-saving function	355
9.2	LAN Connections and Settings	288		Other functions	356
	Connecting a LAN cable	288			
	Configuring LAN settings and building a network environment	290			
9.3	Remotely Operating the Instrument				
	Through the HTTP Server	292			
	Connecting to the HTTP server	293			
9.4	Acquiring Data through the FTP Server	295			
	Accessing the instrument's FTP server	296			

10.4	Detailed Specifications of Measurement	
	Parameters	358
	Basic measurement items	358
	Units and display ranges of measurement items	363
	Harmonic measurement items	366
	Inter-harmonic measurement items (only in IEC measurement mode)	366
	Power range configuration	368
	Special values	371
10.5	Specifications of Equations	375
	Equations for basic measurement items	375
	Equations for motor analysis option	380
	Equations for harmonic measurement items	381
	Equations for integration measurement	383
10.6	Specially Specified Combinatorial Accuracy With Optional Products for Current Measurement	384
11	Maintenance and Service	393
11.1	Repair, Inspection, and Cleaning	393
	Calibration	393
	Replaceable parts and service life	394
	Cleaning	394
11.2	Troubleshooting	395
11.3	Error messages	398
11.4	Warning messages	399
11.5	Frequently Asked Questions	404
11.6	Calculation of the Combinatorial Accuracy	405
11.7	External view	406
11.8	Rackmount fittings	407
11.9	About Technical Information	411
11.10	Block Diagram	412
11.11	Updating the Firmware	413
11.12	Adding Optional Functions	416
11.13	Disposal of the Instrument (How to Remove the Lithium Battery)	419
11.14	Open-Source Software	421
Index		423

Introduction

Thank you for choosing the Hioki PW4001 Power Analyzer. To ensure your ability to get the most out of this instrument over the long term, please read this manual carefully and keep it available for future reference.

Information on download site

For details on the product application, the update file for the instrument, and the instruction manual, please check Hioki's website:

<https://cloud.gennect.net/dl>



Product registration

Register your product in order to receive important product information.

<https://www.hioki.com/global/support/myhioki/registration/>



The instruction manuals listed below are available for the instrument. Refer to them as necessary depending on your application. Please review the separate "Operating Precautions" before using the instrument.

Name of the instruction manual	Description	Format
Operating Precautions	Includes information for using the instrument safely.	Hard copy
Startup Guide	Includes information for using the instrument safely, basic operation methods, and specifications (excerpt).	
Instruction Manual	Includes a product overview for this instrument, operation methods, function descriptions, and specifications.	PDF (download)
Communication Command Instruction Manual	Includes descriptions of communications commands for controlling this instrument.	
Modbus/TCP Communications Instruction Manual	Includes descriptions of communications commands for controlling this instrument via Modbus* ¹ /TCP.	
MATLAB Toolkit User's Manual	Includes information about using the MATLAB* ¹ toolkit to load waveform binary data recorded with this instrument as MATLAB array data and controlling the instrument connected via Ethernet on MATLAB.	
CAN Editor Instruction Manual	Includes information about installing and using the PC application software to configure CAN settings for the instrument.	
PW Data Receiver Instruction Manual	Includes information about installing and using the PC applications and specifications.	
LabVIEW Driver User's Manual	Includes information about controlling the instrument and acquiring measured data using the LabVIEW driver.	
GENNECT One User's Manual	Includes information about installing and using the PC applications and specifications.	

*1 Third-party company's trademark

Target audience

This manual has been written for use by individuals who use the product or provide information about how to use the product. In explaining how to use the product, it assumes electrical knowledge (equivalent of the knowledge possessed by a graduate of an electrical program at a technical high school).

Trademarks

- Microsoft, Microsoft Edge and Windows are trademarks of the Microsoft group of companies.
- Intel is a trademark of Intel Corporation or its subsidiaries in the United States and/or other countries.
- LABVIEW is a trademark of Nialli Inc. in the United States, Canada and other countries.

Font on the screen

DynaFont is a registered trademark of DynaComware Taiwan Inc.

Checking Package Contents

Upon receiving the product, inspect it for any damage or anomalies. If you discover any damage or find that the product does not perform as indicated in the specifications, please contact your authorized Hioki retailer or reseller.

Confirm the package contents.

- PW4001 Power Analyzer

Front

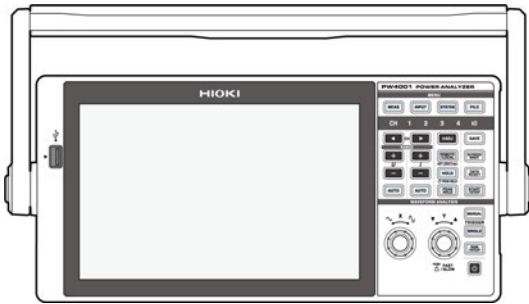

Back (Check the model name written on the sticker.)

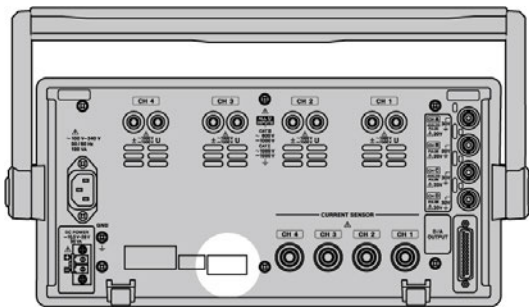

✓ : Function available –: Function not available

Model name (order code)	Optional feature (additional function)		
	Waveform and D/A output	Motor analysis	DC power supply (operates on 10.5 V to 28 V DC)
PW4001-01	–	–	–
PW4001-02	✓	–	–
PW4001-03	–	✓	–
PW4001-04	–	–	✓
PW4001-05	✓	✓	✓

Accessories

- Startup Guide
- Operating Precautions (0990A903)
- Power cord
- USB cable
- D-sub 25-pin connector (PW4001-02 and PW4001-05 only)
- DC power supply connector (PW4001-04 and PW4001-05 only)

Options (Sold Separately)

The options listed below are available for the instrument. To purchase any optional equipment, please contact your authorized Hioki retailer or reseller. Please note that optional equipment offerings are subject to change without advance notice. Check Hioki's website for the latest information.





Factory default options





Optional products that can be specified with the model number (PW4001-xx)

Waveform and D/A output option
Motor analysis option
Optional DC power supply (operates on 10.5 V to 28 V DC)

Optional products for voltage measurement

Safety banana plugs ($\varnothing 4$ mm) can be connected to the voltage input terminals of the instrument. Prepare voltage cords appropriate for your applications.

Product name	Maximum rated voltage and current	Remark
L1025 Voltage Cord 	CAT II 1500 V DC 1000 V AC, 1 A CAT III 1000 V, 1 A	Banana plug-banana plug (red, black $\times 1$ each) (alligator clips included) Cable length: approx. 3 m
L9438-50 Voltage Cord 	CAT III 1000 V, 10 A CAT IV 600 V, 10 A	Banana plug-banana plug (red, black $\times 1$ each) (alligator clips included) Cable length: approx. 3 m
L1000 Voltage Cord 	CAT III 1000 V, 10 A CAT IV 600 V, 10 A	Banana plug-banana plug (red, yellow, blue, gray $\times 1$ each; black $\times 4$) (alligator clips included) Cable length: approx. 3 m
L9257 Connection Cord 	CAT III 1000 V, 10 A CAT IV 600 V, 10 A	Banana plug-banana plug (red, black $\times 1$ each) (alligator clips included) Cable length: approx. 1.2 m
L1021-01 Patch Cord 	CAT III 1000 V, 10 A CAT IV 600 V, 10 A	For distributing voltage input Stackable banana plug-banana plug (red $\times 1$) Cable length: approx. 0.5 m

Product name	Maximum rated voltage and current	Remark
L1021-02 Patch Cord 	CAT III 1000 V, 10 A CAT IV 600 V, 10 A	For distributing voltage input Stackable banana plug-banana plug (black ×1) Cable length: approx. 0.5 m
L9243 Grabber Clip 	CAT II 1000 V, 1 A	Red, black ×1 each
L4940 Connection Cable Set 	CAT III 1000 V, 10 A CAT IV 600 V, 10 A	Banana plug-banana plug (red, black ×1 each) (no alligator clips) Cable length: approx. 1.5 m
L4935 Alligator Clip Set 	CAT III 1000 V, 10 A CAT IV 600 V, 10 A	Red, black ×1 each
VT1005 AC/DC High Voltage Divider 	5000 V, ±7100 V peak CAT III 1500 V CAT II 2000 V	For measuring voltages of 1000 V or more

Optional products for current measurement

For details, refer to the instruction manual that came with the current sensor.

- **Ultra-high accuracy, direct connection**



Auto-recognition function: available
Operating temperature range: 0°C to 40°C (32°F to 104°F)

Model name	Rated current (rms)	Frequency characteristics	Basic accuracy (amplitude) ± (% of reading + % of full scale)	Measurable conductor diameter	Number of channels
PW9100A-3	50 A	DC to 3.5 MHz	±0.02% ±0.005%	Measurement terminals M6 screw	3 channels
PW9100A-4					4 channels

Options (Sold Separately)

• **Ultra-high accuracy, pass-through**



Auto-recognition function: available
 Operating temperature range: -10°C to 50°C (14°F to 122°F)

Model name	Rated current (rms)	Frequency characteristics	Basic accuracy (amplitude) ± (% of reading + % of full scale)	Measurable conductor diameter	Cable length (approximate)
CT6904A	500 A	DC to 4 MHz	±0.02% ±0.007%	∅ 32 mm	3 m
CT6904A-1*1		DC to 2 MHz			10 m
CT6904A-2*1	800 A	DC to 4 MHz	±0.025% ±0.009%		3 m
CT6904A-3*1		DC to 2 MHz			10 m

*1 Product manufactured on a per-order basis

• **High accuracy, pass-through**



Auto-recognition function: not available
 Operating temperature range: -30°C to 85°C (-22°F to 185°F)

Model name	Rated current (rms)	Frequency characteristics	Basic accuracy (amplitude) ± (% of reading + % of full scale)	Measurable conductor diameter	Cable length (approximate)
CT6862-05	50 A	DC to 1 MHz	±0.05% ±0.01%	∅ 24 mm	3 m
CT6863-05	200 A	DC to 500 kHz			



Auto-recognition function: available
 Operating temperature range: -40°C to 85°C (-40°F to 185°F)

Model name	Rated current (rms)	Frequency characteristics	Basic accuracy (amplitude) ± (% of reading + % of full scale)	Measurable conductor diameter	Cable length (approximate)
CT6872	50 A	DC to 10 MHz	±0.03% ±0.007%	∅ 24 mm	3 m
CT6872-01					10 m
CT6873	200 A				3 m
CT6873-01					10 m
CT6875A	500 A	DC to 2 MHz	±0.04% ±0.008%	∅ 36 mm	3 m
CT6875A-1		DC to 1.5 MHz			10 m
CT6876A	1000 A				DC to 1.2 MHz
CT6876A-1		10 m			
CT6877A	2000 A	DC to 1 MHz	±0.04% ±0.008%	∅ 80 mm	3 m
CT6877A-1					10 m

- High accuracy clamp



Auto-recognition function: available

Operating temperature range: -40°C to 85°C (-40°F to 185°F)

Model name	Rated current (rms)	Frequency characteristics	Basic accuracy (amplitude) ± (% of reading + % of full scale)	Measurable conductor diameter	Cable length (approximate)
CT6830	2 A	DC to 100 kHz	±0.3% ±0.05%	∅ 5 mm	4.2 m
CT6831	20 A		±0.3% ±0.01%		
CT6841A	200 A	DC to 2 MHz	±0.2% ±0.01%	∅ 20 mm	3 m
CT6843A		DC to 700 kHz	±0.07% ±0.007%		5 m
CT6833					DC to 50 kHz
CT6833-01		5 m			
CT6834	500 A	DC to 50 kHz	±0.2% ±0.01%	∅ 50 mm	5 m
CT6834-01					10 m
CT6844A	1000 A	DC to 500 kHz	±0.2% ±0.01%	∅ 50 mm	3 m
CT6845A		DC to 200 kHz			
CT6846A	1000 A	DC to 100 kHz			

Options (Sold Separately)

• **General purpose clamp (For measuring commercial power frequency bands)**



Auto-recognition function: not available
 Operating temperature range: 0°C to 50°C (32°F to 122°F)

Model name	Rated current (rms)	Frequency characteristics	Basic accuracy (amplitude) ± (% of reading + % of full scale)	Measurable conductor diameter	Cable length (approximate)
9272-05	20 A 200 A	1 Hz to 100 kHz	±0.3% ±0.01%	∅ 46 mm	3 m

For CT9920 conversion cable





Auto-recognition function: not available
 Operating temperature range: -25°C to 60°C (-13°F to 140°F)

Model name	Rated current (rms)	Frequency characteristics	Basic accuracy (amplitude) ± (% of reading + % of full scale)	Measurable conductor diameter	Cable length (approximate)
CT7642	2000 A	DC to 10 kHz	±1.5%	∅ 55 mm	2.5 m
CT7742		DC to 5 kHz	±0.5%		
CT7044	6000 A	10 Hz to 50 kHz	±1.5% ±0.25%	Approx. 390 mm	
CT7045				Approx. 630 mm	
CT7046				Approx. 870 mm	

Connection cables

Product name	Cable length (approximate)	Remark
L9217 Connection Cord 	1.7 m	CAT II 600 V, 0.2 A CAT III 300 V, 0.2 A For motor analysis input, insulated BNC



Product name	Cable length (approximate)	Remark
9165 Connection Cord 	1.5 m	For BNC synchronization, Metallic BNC-to-metallic BNC
9713-01 CAN Cable 	2 m	One end not terminated
CT9920 Conversion Cable 	0.4 m	PL14 Receptacle - ME15W Plug

Optional additional license



This is a licensed product that allows customers to add optional functions after purchasing the instrument.

License	Optional function	
	Model name	Function overview
PW9006-01	PW9006	IEC harmonics/flicker measurement function

Other optional products

Product name	Remark
C4001 Carrying Case 	Hard trunk type Equipped with casters
Z5302 Rackmount Fittings	EIA-compliant
Z5303 Rackmount Fittings	JIS-compliant
Z5200 BNC Terminal Box 	D-sub 25 pins-to-BNC (female) 20-channel conversion box (up to 16 channels can be used with the PW4001)
L3000 D/A Output Cable 	Cable length: 2.5 m D-sub 25 pins-to-BNC (male) 20-channel conversion cable (up to 16 channels can be used with the PW4001)







Options (Sold Separately)

Product name	Remark
<p data-bbox="161 232 379 259">CT9557 Sensor Unit</p>  A rectangular white electronic device with four channels of output ports on the front panel. Each channel has a small display and several control knobs and buttons.	<p data-bbox="660 271 1362 367">4-channel sensor power supply Includes waveform, summed waveform, and summed RMS output functions</p>
<p data-bbox="161 430 564 456">SP7001-95 Non-Contact CAN Sensor</p>  A small electronic component with two wires extending from it, one ending in a connector and the other in a different type of connector.	<p data-bbox="660 472 852 499">For CAN/CAN FD</p>





Symbols and Abbreviations

Safety



This manual classifies the seriousness of risks and hazard levels as described below.

 DANGER	Indicates an imminently hazardous situation that, if not avoided, could result in death or serious injury.
 WARNING	Indicates a potentially hazardous situation that, if not avoided, could result in serious injury or death.
 CAUTION	Indicates a potentially hazardous situation that, if not avoided, could result in minor or moderate injury or potential risks of damage to the supported product (or to other property).
IMPORTANT	Indicates information or content that is particularly important for the operation and maintenance of the instrument.
	Indicates a high-voltage hazard. Failure to verify safety or improper handling of the instrument could lead to an electric shock, burn, or death.
	Indicates prohibited actions.
	Indicates mandatory actions.

Symbols on the product

	Indicates the presence of a potential hazard. See "Precautions for Use" (p.21) in the instruction manual and warning messages listed at the beginning of each operating instruction, as well as the accompanying document entitled "Operating Precautions".
	Indicates the push-button switch that can turn on and off the product.
	Indicates a grounding terminal.
	Indicates direct current (DC).
	Indicates alternating current (AC).

Symbols for various standards

	Indicates that the product is covered by the Directive on Waste Electrical and Electronic Equipment (WEEE) in EU member nations. Dispose of the product in accordance with local regulations.
	Indicates that the product complies with standards imposed by EU directives.

	Indicates that the product complies with standards imposed by the country of South Korea. Declarer: HIOKI KOREA CO., LTD. https://www.rra.go.kr/selform/HKO-PW4001S
---	---

Others

	Indicates useful advice concerning instrument performance and operation.
*	Indicates additional information is provided below.
(p.)	Indicates the page number to refer to.
START (Bold letters)	Indicates the names of the control keys.
[]	Indicates the names of user interface elements on the screen.
Windows	Unless otherwise noted, the term Windows is used generically to refer to Windows 11.
Current sensors	Sensors for measuring currents are collectively referred to as “current sensors”.
S/s	For this instrument, the number of times the analog input signal is digitized is indicated in samples per second (S/s). For example, 20 MS/s (20 megasamples per second) signifies 20×10^6 samples per second.

Accuracy labeling

The accuracy of the measuring instrument is expressed using a combination of the formats shown below:

- By defining limit values for errors using the same units as measured values.
- By defining limit values for errors as a percentage of the reading, a percentage of the full scale, a percentage of the range, and in terms of digits.

Reading (display value)	Indicates the value displayed by the instrument. Limit values for reading errors are expressed as a percentage of the reading (% of reading or % rdg).
Range	Indicates the measurement range of the instrument. Limit values for range errors are expressed as a percentage of the range (% of range or % rng).
Full scale (rated current)	For this instrument, this mainly indicates the rated current of the current sensor. Limit values for full-scale errors are expressed as a percentage of the full scale (“% f.s.”).
Digit (resolution)	Indicates the minimum display unit (in other words, the smallest digit that can have a value of 1) for a digital measuring instrument. Limit values for digit errors are expressed in terms of digits.

Safety Information

This instrument has been designed in accordance with the international standard IEC 61010 and has undergone rigorous safety testing prior to shipment. However, using the instrument in a way not specified in this manual may compromise its safety features.

Please review the safety precautions below before using the instrument.

DANGER



■ **Familiarize yourself with the contents of this manual before use.**

Failure to follow this guidance will result in misuse, leading to serious bodily injury or damage to the instrument.

WARNING



■ **If you have not previously used electrical measuring instruments, ensure adequate supervision by a technician with experience in electrical measurement.**

Failure to do so could cause the operator to experience an electric shock. It could also cause serious incidents, such as heat generation, fire, or arc flash due to a short-circuit.

Measurement category

IEC 61010 defines measurement categories to facilitate safe use of measuring instruments. Test and measurement circuits designed to be connected to a main power supply circuit are classified into three categories depending on the type of main power supply circuit. A measuring instrument that does not have a measurement category cannot be used to measure a main power supply circuit.

DANGER



■ **Do not use a measuring instrument to measure a main power supply circuit whose category exceeds the instrument's rated measurement category.**

■ **Do not use a measuring instrument that does not have a rated measurement category to measure a main power supply circuit.**

Doing so may result in serious bodily injury or damage to the instrument or other equipment.

No measurement category (O)	Applicable to the measurement of other circuits that are not directly connected to the main power supply. Example: Measurement on the secondary-side equipment from the socket outlet of fixed equipment through a transformer, etc.
Measurement category II (CAT II)	Applicable to test and measuring circuits connected directly to utilization points (socket outlets and similar points) of a low-voltage MAINS installation. Example: Measurements on household appliances, portable tools, and similar equipment, and on the consumer side only of socket outlets in the fixed equipment.

Safety Information

<p>Measurement category III (CAT III)</p>	<p>Applicable to test and measuring circuits connected to the distribution part of a building's low-voltage MAINS installation. Example: Measurements on distribution boards (including secondary meters), photovoltaic panels, circuit breakers, wiring, including cables, busbars, junction boxes, switches, and socket outlets in fixed equipment, as well as equipment for industrial use and some other equipment such as stationary motors with permanent connection to the fixed equipment.</p>
<p>Measurement category IV (CAT IV)</p>	<p>Applicable to test and measuring circuits connected at the source of a building's low-voltage MAINS installation. Example: Measurements on devices installed before the main fuse or circuit breaker in the building installation.</p>

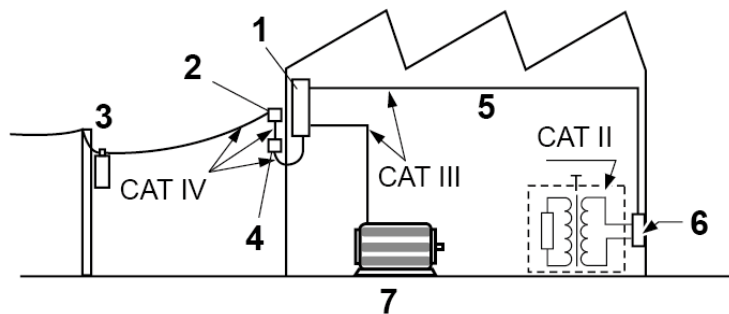

<p>1</p>	<p>Distribution panel</p>
<p>2</p>	<p>Service entrance</p>
<p>3</p>	<p>Service drop</p>
<p>4</p>	<p>Power meter</p>
<p>5</p>	<p>Interior wiring</p>
<p>6</p>	<p>Outlet</p>
<p>7</p>	<p>Fixed equipment</p>

Precautions for Use

Be sure to follow the precautions listed below in order to use the instrument safely and in a manner that allows it to function effectively.

Use of the instrument should conform not only to its specifications, but also to the specifications of all accessories, options, and other equipment in use.

Installing the instrument

WARNING

■ **Do not use the instrument in locations such as the following:**

- Where it would be subject to direct sunlight or high temperatures
- Where it would be exposed to corrosive or explosive gases
- Where it would be exposed to powerful electromagnetic radiation or close to objects carrying an electric charge
- Where it would be close to an inductive heating device (such as high-frequency inductive heating devices and IH cooktops)
- Where it would be subject to a large amount of mechanical vibration
- Where it would be exposed to water, oil, chemicals, or solvents
- Where it would be exposed to high humidity or condensation
- Where it would be exposed to an excessive amount of dust
- Where it would be unstable or inclined



Doing so could damage the instrument or cause it to malfunction, resulting in bodily injury.

■ **Place the instrument, leaving enough space around it to facilitate unplugging the power cord.**



If there is not enough space left around, the power cannot be shut off immediately in an emergency.

Failure to follow this guidance could result in bodily injury, fire, or damage to the instrument.

- Leave at least 50 mm of space on every surface other than the underside to keep the instrument's temperature from rising (❶).
- Place with its bottom side facing downward.
- Do not block any side vents.

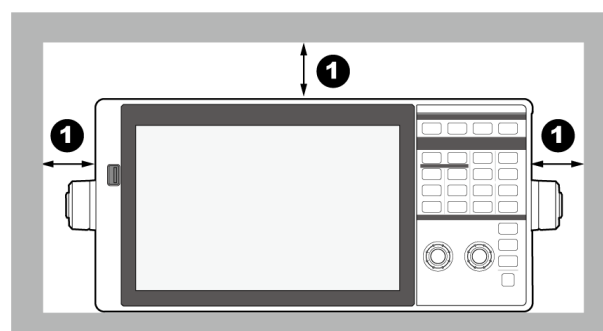

Handling the instrument

WARNING



- **If smoke, abnormal sounds, strange odor, or other abnormalities occur, immediately unplug the power cord from the outlet and remove measurement leads and sensors.**

Failure to do so could result in serious bodily injury or fire.

See “11.2 Troubleshooting” (p.395) and “11.3 Error messages” (p.398) before contacting your authorized Hioki retailer or reseller.

CAUTION



- **Do not route cords between other objects or step on them.**
- **Do not bend or pull on cords where they connect.**

Doing so could break cables.

- **Do not bend or pull on the cables at temperatures of 0°C (32°F) or lower.**

The cables could harden in low temperatures. Bending or pulling them under these conditions could break the cable or damage the insulation, resulting in electric shock.

The instrument is classified as a Class A device under the EN 61326 standard. Use of the instrument in a residential setting such as a neighborhood could interfere with reception of radio and television broadcasts. If you encounter this issue, take steps as appropriate to address it.

Cautions for measurement

DANGER



- **Do not use the instrument for measurements on any circuits that exceed the ratings or specifications of the instrument.**

Doing so could cause damage to the instrument or cause it to overheat, resulting in serious bodily injury.

[See](#) “10.2 Specifications of Input, Output, and Measurement” (p.319)

WARNING



- **Do not touch the wires being measured.**

The wires being measured could become hot, possibly resulting in burns.

CAUTION



- **Do not input voltage or current to the input terminal when the instrument has been turned off.**

Doing so could damage the instrument.

Cautions for transporting the instrument

CAUTION



■ Do not subject the instrument to vibration or mechanical shock while transporting or handling it.

Doing so could damage the instrument.

When carrying the instrument, remove the cords and the USB flash drive and hold the handles.

Shipping Precautions

- When shipping the instrument, use the box and packaging materials in which it was originally shipped, or use the C4001 Carrying Case. However, do not use the original box and packaging materials if they are damaged. If the original box and packaging materials cannot be used, contact your Hioki retailer or reseller. You will be sent a suitable box and packaging materials.
- When packing the instrument, make sure to disconnect the cords and remove the USB flash drive.
- When transporting the product, exercise care to avoid dropping it or otherwise subjecting it to rough handling.

Measurement Procedure

The basic measurement procedure with the instrument is as follows.

1 Inspect the instrument before use.

🔍 See “2.1 Inspecting the Instrument before Use” (p.52)

2 Prepare for measurement.

🔍 See “2.2 Connecting the Voltage Cords (Voltage Input)” (p.54)

🔍 See “2.3 Connecting the Current Sensors (Current Input)” (p.55)

🔍 See “2.4 Supplying Power to the Instrument” (p.60)

Allow the instrument to warm up for 30 minutes or more after turning on the instrument before performing the zero adjustment.

3 Set wiring modes and configure current sensor settings.

🔍 See “2.5 Setting Wiring Mode and Configuring Current Sensor Settings” (p.66)

4 Configure Simple Setup (Quick Set).

🔍 See “2.6 Simple Configuration (Quick Set)” (p.70)

5 Perform the zero adjustment.

🔍 See “2.8 Zero Adjustment and Degaussing (Demagnetization)” (p.74)

Always perform zero adjustment before connecting measurement leads and sensors.

6 Connect the sensor and leads to the lines to be measured.

🔍 See “2.9 Connecting Measurement Leads and Sensors to Lines to Be Measured” (p.75)

7 Verify proper connection.

🔍 See “2.10 Checking Connections” (p.78)

8 View the measured values and waveforms.

🔍 See “3 Displaying Power Numerically” (p.81)

🔍 See “4 Displaying Waveforms” (p.149)



Starting/stopping the integration



Displaying the waveforms

9 Save the data.

🔍 See “7 Saving Data and Managing Files” (p.199)

10 Analyze the data.

🔍 See “8 Connecting External Devices” (p.239)

🔍 See “9.1 USB Connections and Settings” (p.285)

🔍 See “9.2 LAN Connections and Settings” (p.288)

🔍 See “9.8 GENNECT One (PC Application Software)” (p.311)

11 Finish the measurement.

1 Overview

1.1 Product Overview

This instrument is a power analyzer that can analyze the power conversion efficiency by simultaneously measuring the input and output powers of an object under measurement. The instrument comes standard with four voltage inputs and four current inputs, enabling various lines to be measured according to your applications by combining wiring configurations from single-phase to three-phase four-wire configurations.

1.2 Features

● High-precision measurement of various power sources

Includes four channels for both voltage input and current input.

The instrument can measure multiple circuits at high precision, such as simultaneous measurement of the primary side and secondary sides of an inverter.

Maximum input voltage	1000 V AC, 1500 V DC
Measurement frequency band	DC, 0.1 Hz to 600 kHz
Sampling frequency	2.5 MHz, 16-bit
Basic accuracy	±0.03% of reading, ±0.01% of range

● Automatically recognizes current sensors

🔍 See “Current sensor auto-recognition function” (p.67)

The instrument automatically acquires information on current sensors connected to itself and compensates for their phase errors.

This significantly reduces the setting time before measurement and strongly supports accurate power measurement.



① Automatically acquiring information

② Powered by PW4001



● Simple Configuration (Quick Set)

🔍 See “2.6 Simple Configuration (Quick Set)” (p.70)

The Quick Set function allows measurement conditions to be set to typical values at once according to the selected lines to be measured.

● Various motor analysis functions (optional)

Motor power can be measured by inputting signals from torque meters and tachometers. In addition to motor parameters such as motor power and electrical angle, output signals from solarimeters and anemometers can also be measured.

Operating mode	Single	Dual	Independent input
			
Ch. A	Torque	Torque	Voltage, pulse
Ch. B	A-phase	RPM	Pulse
Ch. C	B-phase	Torque	Voltage, pulse
Ch. D	Z-phase	RPM	Pulse
Object under measurement	Motor ×1	Motor ×2 Motors, transmissions, etc.	Output signals from solarimeters, anemometers, etc.
Measurement parameters	Electrical angle Rotation direction Motor power RPM Torque Slip	Motor power ×2 RPM ×2 Torque ×2 Slip ×2	Voltage ×2 and pulse ×2, or pulse ×4

● Waveform and D/A output function for long-term observation of power fluctuations (optional)

The instrument includes 16 channels of waveform and D/A output and can record voltage/current waveforms and long-term fluctuations in measured values.

● DC power supply function for an expanded range of applications (optional)

The instrument can also be powered by a DC power supply. By using a separate external battery (10.5 V to 28 V DC), you can perform highly precise power measurements even in situations where commercial power is unavailable.

● Comes standard with a CAN interface

With the CAN output function, measured data can be output as CAN/CAN FD signals to the CAN bus in real time.

With the CAN input function, CAN signals can be measured and recorded in real time.



1 Measuring power fluctuation

② CAN analysis system

③ Power measuring CAN bus and automotive CAN bus

● **Up to 32 channels can be measured using BNC synchronization**

Data updates and integration control can be synchronized for up to eight instruments, including a primary instrument and up to seven secondary instruments.

1.3 Part Names and Functions

The illustration shows PW4001-05.

Front

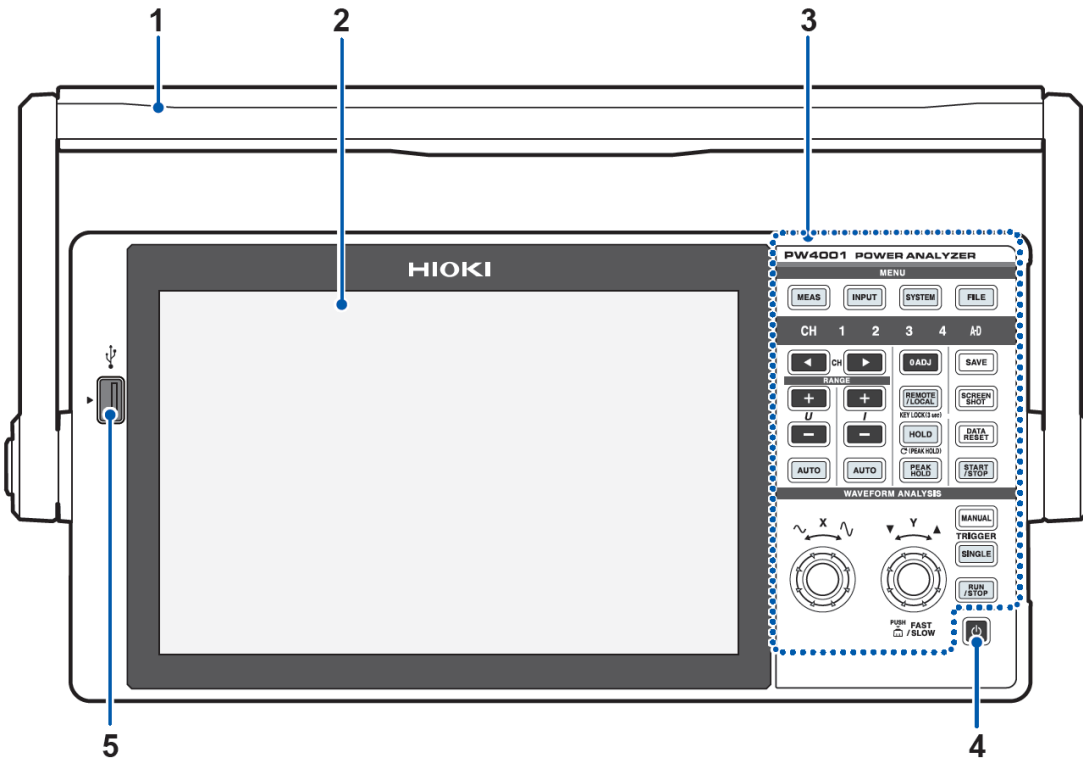

1	Handle	Use when carrying the instrument. It can also be rotated to enable use as a stand. See "Using the handle as a stand" (p.36)
2	Display area	This is a touchscreen. Screen displays and settings can be changed just by touching it. See "Screen operation" (p.37)
3	Control area	Make various settings using the keys and rotary knobs. See "Part Names and Functions" (p.30)
4	Power key	Use to turn the power on and off. See "Turning the instrument on" (p.64) "Turning the instrument off" (p.65)
5	USB port	Connect a USB flash drive to save various types of data, including measured data, setting details, and screenshots. The port cannot be used with any other devices, including a mouse and a keyboard. See "7.2 USB flash drive" (p.201)

Handling the touchscreen

CAUTION

- Do not press too hard on the touchscreen.
- Do not use hard or sharp objects to operate the touchscreen.
Doing so could damage the instrument.

Engaging key lock





Press the **REMOTE/LOCAL** key for 3 s to lock the key operations.

Both key operation and touchscreen operation are entirely disabled while the key lock function is engaged, except key operation used to cancel the key lock state. The key lock state will persist even if the instrument is cycled.

Key operation area

MENU keys (switching screens)

Pressing a key causes the selected key to light up and the screen to switch over to the selected screen.

	Displays the Measurement screen. The Measurement screen displays measured values and waveforms. See “3.1 Displaying Measured Values” (p.81)
	Displays the Input Settings screen. The Input Settings screen is used to configure settings related to input, wiring mode, measurement, and calculations. See “2.5 Setting Wiring Mode and Configuring Current Sensor Settings” (p.66)
	Displays the System Settings screen. The System Settings screen is used to configure settings related to time control, interfaces, and other functionality. See “6.1 Checking and Changing Settings” (p.189)
	Displays the File Operation screen. Use this screen to manipulate data from the internal memory or USB flash drive. See “7 Saving Data and Managing Files” (p.199)

Channel indicators



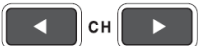
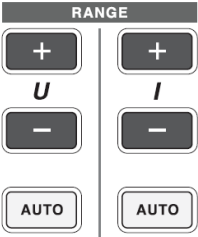

The display settings of the **RANGE** key and the setting indicator affect the input channels that are lit up.

The channels included in a single wiring configuration based on the wiring settings light up simultaneously.









	Channel selection key Selects the channel to display on the Measurement screen. The channel indicators light up linking to the channel selection key.
	<p>RANGE keys</p> <p>The + and - keys of U can switch the voltage range, while the + and - keys of I can switch the current range. These affect the ranges of the channel with its channel indicator LED lit up.</p> <p>When the [A-D] channel indicator is lit up, the U keys function for Ch. A analog input, while the I keys function for Ch. C analog input. When the AUTO key is lit up, auto-ranging operation is canceled at the time when the range is switched.</p> <p>AUTO keys</p> <p>The AUTO key in the U area enables the auto-ranging function for voltage, while the AUTO key in the I area enables the auto-ranging function for current. The keys will light up. The key light turns off if pressed again, and the range will be fixed to the present setting at that time. The keys function for the channels with their channel indicators are lit up.</p>

1.3 Part Names and Functions

	<p>Performs zero adjustment for the input channels. See “2.8 Zero Adjustment and Degaussing (Demagnetization)” (p.74)</p>
	<p>Saves measured data onto the USB flash drive or internal memory when the key is pressed. See “7.2 USB flash drive” (p.201)</p>
	<p>Saves the screen image onto the USB flash drive or internal memory when the key is pressed. See “7.7 Saving and Loading Screenshots” (p.220)</p>
	<p>REMOTE/LOCAL key (key lock) Lights up when updating firmware via the Remote Operation screen. Keys cannot be operated when lit up. If the key is held down for at least 3 s, the key lock is activated and the key lock icon is displayed on the screen. If the key is held down again for at least 3 s, the setting is released, and the key light turns off.</p>

Measurement control keys









The measurement control keys function primarily to control power measurement functions. They do not affect the waveform display.

	<p>Turns the hold function on and off. The key is lit up when the hold function is enabled. Pressing while the peak hold function is enabled will clear the peak hold data. See “5.3 Hold function” (p.171)</p>	
	<p>Turns the peak hold function on and off. The key is lit up when the hold function is enabled. Pressing while the hold function is enabled will update the hold data. See “5.4 Peak hold function” (p.173)</p>	
	<p>Resets integrated data. This key functions for the channels in which the integration is stopped. See “How to start/stop integration and resetting integrated values” (p.100)</p>	
	<p>Controls starting and stopping of the integration and auto-save operation. The key does not lights up when each wiring-configuration integration is enabled. See “How to start/stop integration and resetting integrated values” (p.100)</p>	
	 <p>(Lit up in green)</p>	<p>Integration or auto-save operation is in progress.</p>
	 <p>(Lit up in red)</p>	<p>Integration or auto-save operation is stopped. If the DATA RESET key is pressed, the START/STOP key light turns off.</p>

Waveform control keys (rotary knobs)

The waveform control keys function primarily to control waveform capture.

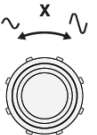
	<p>Forcibly applies a trigger while the instrument is waiting for a trigger (manual trigger). The trigger is applied when the key is pressed, causing recording to start. See “Configuring the trigger settings” (p.156)</p>
---	---

	The waveform is recorded once. 🔍 See “4.3 Recording Waveforms” (p.159)	
	 (Lit up in green)	If the key is pressed, the key lights up in green and the instrument enters the trigger standby state. Recording will start when a trigger is activated.
	(Off) +  (Lit up in red)	Recording will stop once data has been recorded for the recording length. Pressing the RUN/STOP key while the instrument is in the standby state will cause recording to stop.
	Enables waveforms to be recorded continuously. The key lights up in green when pressed and then turns red when pressed again. 🔍 See “4.1 Waveform Display Method” (p.149)	
	 (Lit up in green)	The instrument is in the trigger standby state. Recording will start when a trigger is activated. The instrument will enter the trigger standby state repeatedly.
	 (Lit up in red)	Recording will stop.
<p>Rotary knob</p> <p>The rotary knobs function primarily to zoom waveforms in or out and to change the position or cursor. They are also used to set the parameters whose numerical value will increase or decrease.</p> <div style="display: flex; justify-content: space-around; align-items: center;"> <div style="text-align: center;">  </div> <div style="text-align: center;">  </div> </div> <p>When you tap the button you wish to use on the screen, the corresponding rotary knob lights up.</p> <p>Some items can be changed using the Y rotary knob. Pressing the Y rotary knob toggles between green and red lights, allowing you to change increments.</p> <p>Tapping the original key again will turn the rotary knob light off. When its light stays out, the knob does not work.</p> <p>🔍 See “4.2 Changing the Waveform Display and Configuring Recording” (p.152)</p>		

Rear

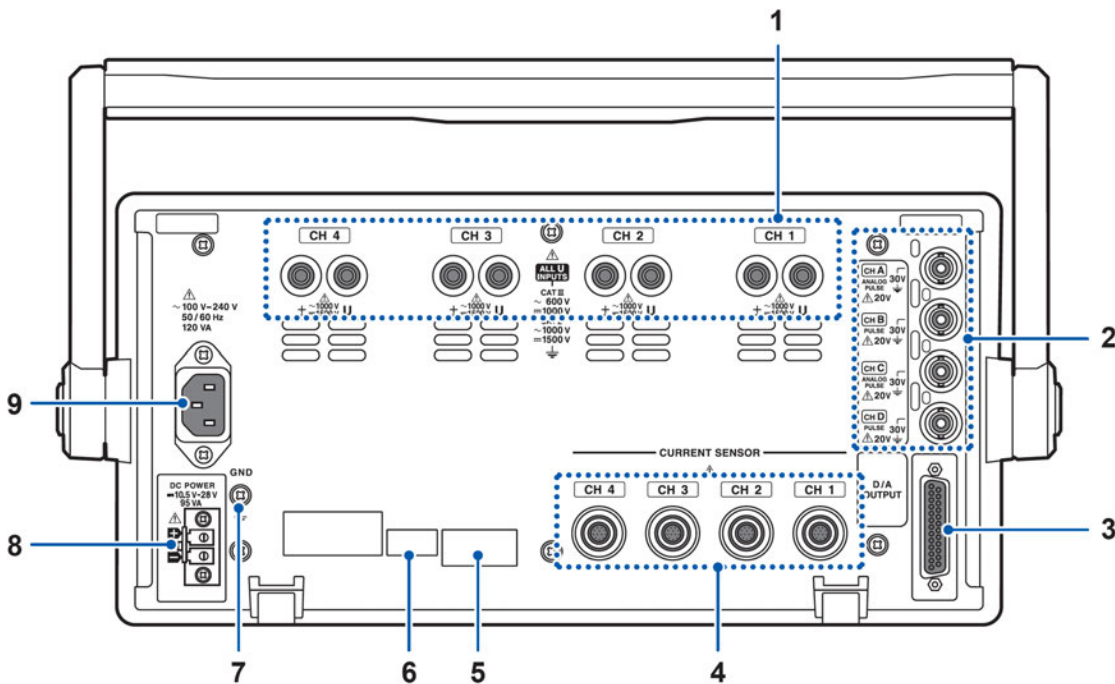

1	Voltage input terminals	Connect optional voltage cords. See “2.2 Connecting the Voltage Cords (Voltage Input)” (p.54)
2	Motor analysis option (External input)	You can input torque sensor and tachometer output to measure motor output. See “3.6 Motor Measurement (Motor Analysis-Equipped Model)” (p.123)
3	Waveform and D/A output option	You can input the instrument’s output into a recorder to record data over an extended period of time. You can also input this signal to an oscilloscope to observe the waveform. See “8.2 Waveform/Analog Output (Waveform and D/A Output Option)” (p.242)
4	Current input terminal	Connect an optional current sensor. The instrument automatically recognizes the current sensor. It also supplies power to the current sensor. See “2.3 Connecting the Current Sensors (Current Input)” (p.55)
5	Model name (top)	This is the model name (order code). Option specifications will vary depending on the suffix. See “Checking Package Contents” (p.9)
	Serial number (bottom)	Check Hioki’s website for the latest information. Do not remove this sticker because the number is required for product tracking. The serial number can be checked on the System screen. See “6.1 Checking and Changing Settings” (p.189)
6	MAC address	This is the MAC address allocated to the instrument. Do not remove this sticker because the number is required for product tracking.

7	Function ground terminal	<p>Grounding this terminal may enhance noise resistance when measuring in noisy locations.</p> <p>When using the DC power supply option, make sure to ground the function ground terminal using a wire. Also, when using on a vehicle, make sure to connect with the body ground using a wire.</p> <p>See “When using a DC power supply (DC power supply option)” (p.61)</p>
8	DC power supply option (operates on 10.5 V to 28 V DC)	<p>Enables the instrument to be powered by a DC power supply, such as a battery.</p> <p>See “When using a DC power supply (DC power supply option)” (p.61)</p>
9	Power supply inlet	<p>Connect the included power cord.</p> <p>See “2.4 Supplying Power to the Instrument” (p.60)</p>

Right side and left side

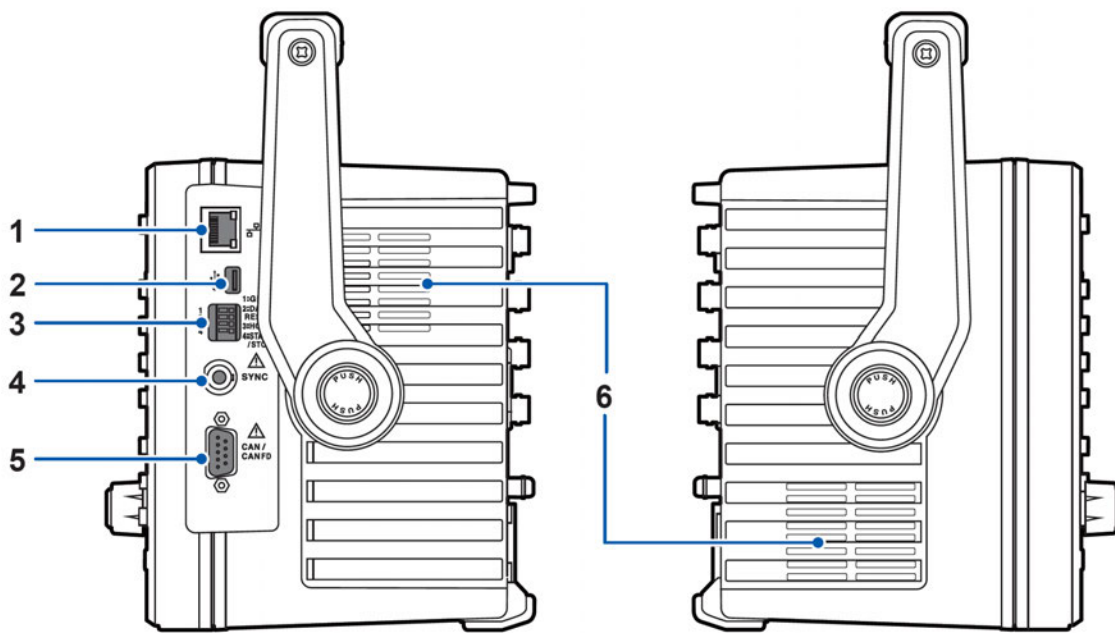

1	RJ-45 connector (Gigabit Ethernet)	<p>Controls the instrument remotely over a LAN. Transfers measured data to a PC.</p> <p>See “9.2 LAN Connections and Settings” (p.288)</p>
2	USB port (mini-B type)	<p>Transfers measured data to a PC.</p> <p>See “9.1 USB Connections and Settings” (p.285)</p>
3	External control terminal	<p>Controls starting and stopping of integration with a contact switch.</p> <p>See “8.3 Controlling Integration with External Signals” (p.254)</p>
4	BNC synchronization connector	<p>Connect the 9165 Connection Cable. Performs measurement using up to 8 synchronized instruments.</p> <p>See “BNC synchronization” (p.239)</p>
5	CAN/CAN FD connector	<p>With the CAN output function, measured data can be output as CAN/CAN FD signals to the CAN bus in real time.</p> <p>With the CAN input function, CAN signals can be measured and recorded in real time.</p> <p>See “8.4 CAN output function” (p.257)</p>

6	Air vent	These ventilation holes prevent the inside of the instrument from becoming too hot. Make sure to place the instrument in a manner that prevents these holes from being blocked. See "Installing the instrument" (p.21)
---	----------	---

Using the handle as a stand

CAUTION

-  Do not apply excessive downward force to the instrument when using its handle as stands.
Failure to follow this guidance could damage the handle.

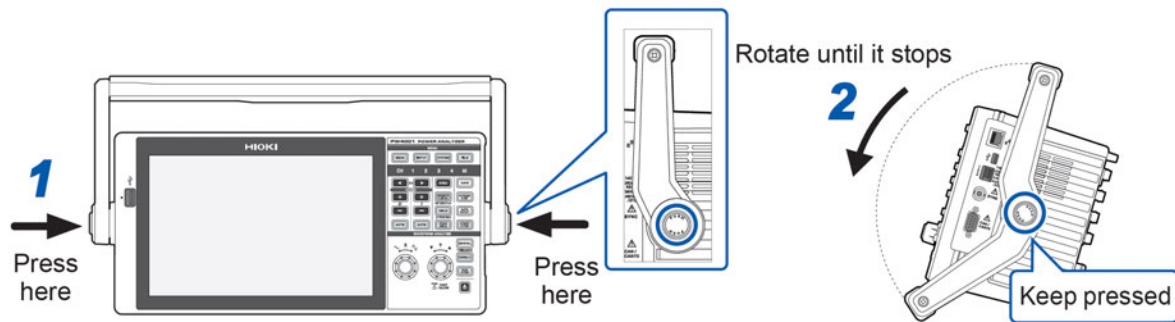

1.4 Basic Operation (Screen Display and Layout)

Screen operation

1 Switch the screens.

See “Screen configurations” (p.45)

2 Select a screen.

Tap an on-screen icon to switch screens.

The icon for the currently selected screen is shown with a blue background.

On the Measurement screen, which appears when the **MEAS** key is pressed, tapping an on-screen icon can display other multiple icons to its left.

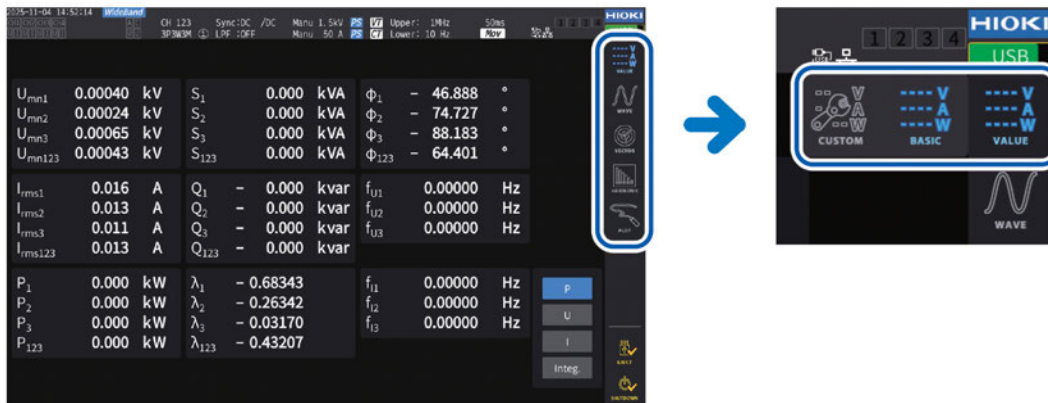

3 Change the displayed contents and settings.

Tap active areas of the screen to control it.

Parameters will appear dimmed if they cannot be set (you cannot tap-activate them).



In principle, you can tap-activate the blue, gray, and white buttons and combo box, as well as the icons on the right side of the screen.

There are exceptions including the cursor on the Waveform screen and the switching of the displayed orders on the list screen.

In addition, tapping outside the setting window closes it.

1.4 Basic Operation (Screen Display and Layout)

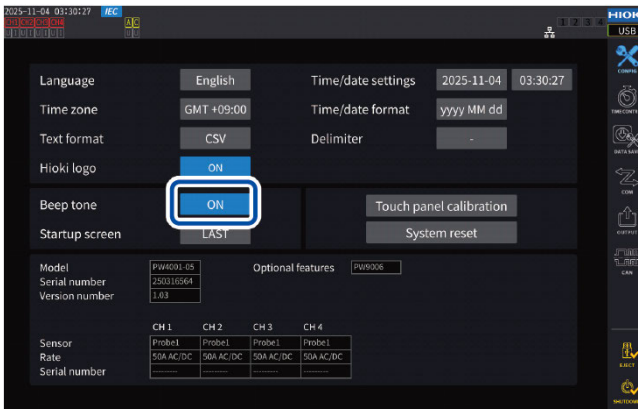

Switching between [ON] and [OFF]

Tap the button to toggle between on and off.

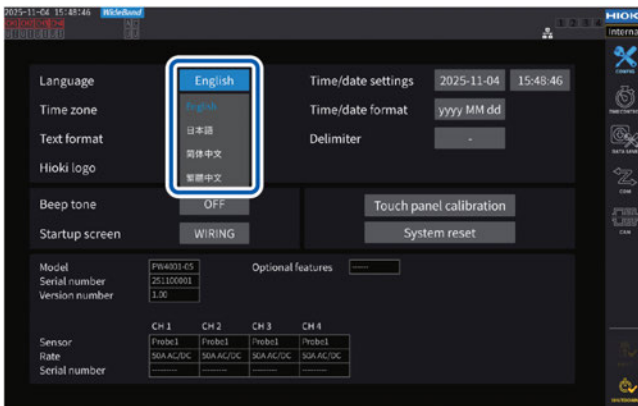

Selecting items

Tap an option to select it.

Tapping outside the list of options will close the list without changing the setting.



Window

While the window is being displayed, the control area and touchscreen keys outside the window may be temporarily disabled.

Once you have finished configuring the settings as desired, tap [x] to close the window.

There are three types of windows:

- Parameter selection window
- “Keyboard window” (p.39)
- “Numeric keypad window” (p.39)

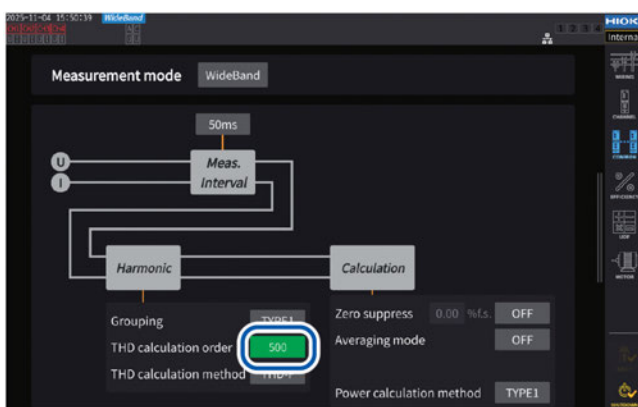

Changing values with rotary knobs

Tap the screen. The edge of one of the instrument's rotary knobs lights up. You can turn that knob to change the value or manipulate the waveform.

Tapping the screen can confirm the value you set.

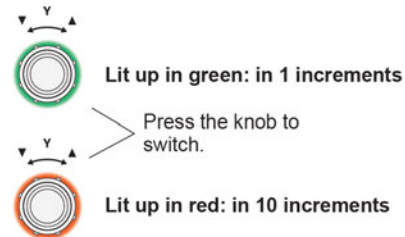

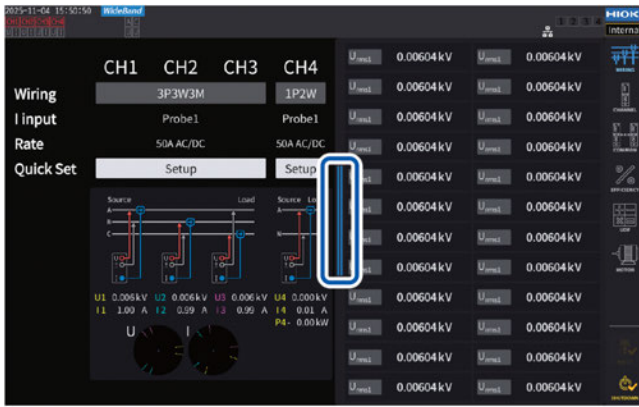

Preview window

This window can be used to easily check how settings affect the measurement results. If this window is unnecessary, tap the double bar to minimize it. When minimized, the window can be displayed again by tapping the double bar. You can also swipe the window to move it to the left or right.

Keyboard window

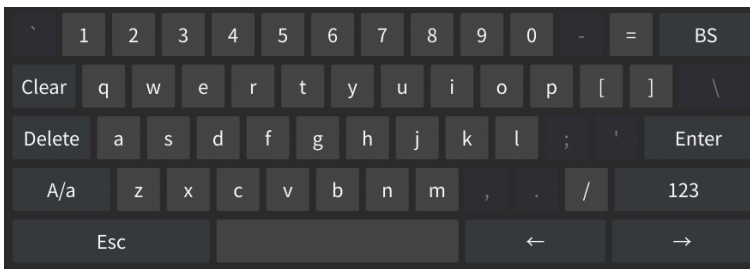

You can enter comments, units, and folder names using the keyboard. While this window is open, you can tap the inside of the window only.

Clear	Clears all entered text.
Delete	Deletes the character at the cursor position.
A/a	Toggles between uppercase and lowercase keyboards.
Esc	Cancels text entry and closes the window.
BS	Deletes the character before the cursor position.
Enter	Accepts the entered text and closes the window.
123	Switches among letters, numbers, and symbols.
← →	Moves the cursor position left and right.

Numeric keypad window

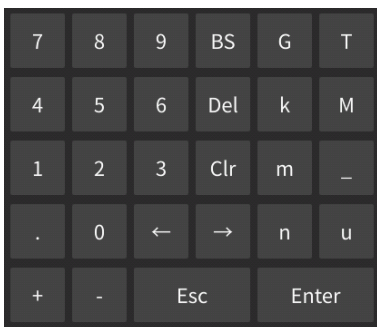

You can enter numerical values. While this window is open, you can tap the inside of the window only.

1.4 Basic Operation (Screen Display and Layout)

BS	Deletes the number before the cursor position.
Del	Deletes the number at the cursor position.
Clr	Clears all entered text.
← →	Moves the cursor position left and right.
Enter	Accepts the entered numerical values and closes the window.
Esc	Cancel text entry and closes the window.
+, -	This button is displayed when a sign can be entered.
T, G, M, k _, m, μ, n	These buttons are displayed when a prefix such as k (kilo) or M (mega) can be entered. Choosing the underscore (_) will clear the prefix. These buttons are not displayed when a prefix cannot be entered.

Common screen display

The following is an example screen. Actual screens vary depending on the instrument's settings. This section describes the screen elements that are shown on all screens.



1. Real time

2. Setting indicator

🔍 See “Measurement screen” (p.43)

3. Operating state indicator

	In the hold state
	In the peak hold state
	Key locked
	Set as the BNC-sync primary instrument.
	Set as the BNC-sync secondary instrument.
	CAN output in progress
	Displays the operation status of each channel in the following colors during integration measurement 🔍 See “Integration Measurement” (p.98) (green) Integration start (red) Integration stop (yellow) Integration standby (colorless) Data reset
	When connected to a network via the LAN interface
	When connected to a computer via USB cable

4. HIOKI logo indicator

Displays the HIOKI logo. It can be shown or hidden.

🔍 See “Checking and Changing Settings” (p.189)

5. Media indicator

Usage of the internal memory [**Internal**] or USB flash drive [**USB**] is indicated using a level meter.

The indicator lights up in red if the media usage rate exceeds 95% or ERROR occurs.

🔍 See “Data Save Destination” (p.203)

6. Warning indicator

In the following example, the Ch. 1 current input is in an overloaded condition (yellow), Ch. 2 is in a synchronization-unlocked condition (red), and the Ch. 3 voltage input is in a peak-over condition (red).



The top row displays the synchronization state for each input channel.

Ch. 1, Ch. 2, Ch. 3, Ch. 4	Input channels	Red: Fundamental power calculation is in a synchronization-unlocked condition. Yellow: Harmonic analysis is in a synchronization-unlocked condition. Gray: Measuring normally.
A, C	Motor input channels	Yellow: The channel is in a synchronization-unlocked condition. Gray: Measuring normally.

The bottom row displays the range-peak-over state for each input channel.

U	Voltage input	Gray: Measuring normally. Yellow: An overload condition occurs.
I	Current input	Red: A peak exceeds the threshold.

Overload-conditions

Overload	RMS value is greater than 150% of the range. The 1500 V range is 100% of range
Peak-over	Peak value is greater than 300% of the range. Peak values are used for internal calculation before passing through the digital LPF.

Measurement screen

The following is an example of the Measurement screen. Actual screens vary depending on the instrument's settings.

This section describes contents shown only on the Measurement screen. This area is called the “setting indicators”.

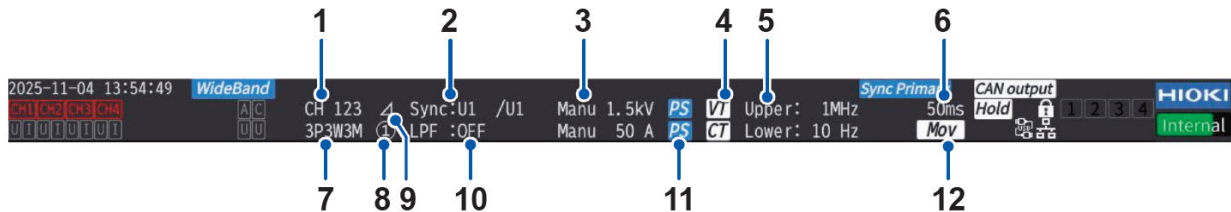





1	Combined channels	Channels that have been combined in the same wiring configuration See “2.5 Setting Wiring Mode and Configuring Current Sensor Settings” (p.66)
2	Synchronization source	Source settings that determine the period (between zero-crossing points) that serves as the basis for measurement Left: Synchronization source for the basic measurement parameters Right: Synchronization source for the harmonic measurement parameters See “Synchronization source” (p.91)
3	Switching ranges	The top row indicates the voltage setting, while the bottom row indicates the current setting. [Auto] : Auto-ranging function enabled [Manu] : Auto-ranging function disabled See “Voltage range and current range” (p.86)
4	Scaling	VT ratio and CT ratio settings See “Scaling (when using VTs [PTs] or CTs)” (p.97)
5	Upper measurement frequency limit Lower measurement frequency limit	[Upper] : Measurement upper frequency limit setting [Lower] : Measurement lower frequency limit setting See “Measurement upper frequency limit and lower frequency limit (configuring frequency measuring range)” (p.94)
6	Data update interval	Data update interval setting See “Data update interval” (p.89)
7	Wiring mode	Wiring configuration See “Setting Wiring Mode and Configuring Current Sensor Settings” (p.66)
8	Current sensor type	[1] : A current sensor other than the CT9920 is connected to the current input terminal [3] : The CT9920 current sensor is connected to the current input terminal See “Connecting a CT7000 Series sensor” (p.58)
9	Delta conversion setting	Operating state of the delta conversion function [Δ] : Delta conversion enabled Blank: Delta conversion disabled See “5.5 Delta Conversion Function” (p.175)
10	LPF	Low-pass filter settings See “Low-pass filter (LPF)” (p.93)
11	PS	Displayed when the phase compensation function is enabled

1.4 Basic Operation (Screen Display and Layout)

12	Average	Average settings [Mov] : Moving average [Exp] : Exponential average Blank: Disabled 🔍 See "5.2 Average Function" (p.168)
----	---------	--

Screen configurations

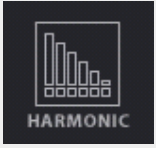

Measurement screen (displayed with the **MEAS** key)

	[VALUE] Measured value screen	[BASIC] Basic display	Displays measured power values for each channel and motor input measured values for each wiring configuration
		[CUSTOM] Selection display	Displays measured values for user-selected basic measurement parameters
	[WAVE] Waveform screen	[WAVE] Displaying Waveforms	Displays the voltage, current, power and motor input waveforms
		[WAVE+VALUE] Waveform + measured value display	Displays measured values, which are expressed numerically, together with waveforms
		[WAVE+ZOOM] Waveform + zoom display	Displays an enlarged view of waveforms
	[VECTOR] Vector screen	[VECTOR×1] 1-vector diagram	Displays a Vector diagram display along with measured harmonic values, which are expressed numerically, of selected order components
		[VECTOR×2] 2-vector diagram	Displays vectors of selected wiring configurations on two vector diagrams
		[VECTOR×4] 4-vector diagram	Displays vectors of selected wiring configurations on four vector diagrams
	[HARMONIC] Harmonic screen	[LIST] List display	Displays a list that includes measured harmonic values, which are expressed numerically, of selected measurement parameters
		[BAR GRAPH] Graph display	Displays bar graphs that include measured harmonic data of selected channels
	[PLOT] Plot screen	[TREND] Trend display	Displays a graph of selected measured values as a time series

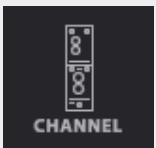
Input screen (displayed with the **INPUT** key)

	[WIRING] Wiring configurations	Allows you to set the wiring pattern (input channel configuration) based on the lines to be measured.
	[CHANNEL] Channel-specific settings	Allows you to set detailed measurement conditions for each channel selected based on the wiring pattern.

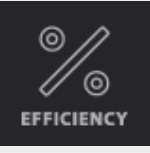
1.4 Basic Operation (Screen Display and Layout)

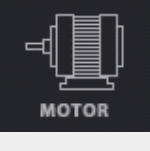
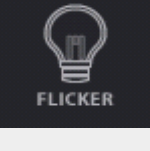
	[COMMON] Common input settings	Allows you to set measurement conditions applied to all channels commonly.
	[EFFICIENCY] Efficiency calculation settings	Allows you to set the equations to calculate efficiency.
	[UDF] User-defined formula	Allows you to arbitrarily set up math formulas by combining values measured by the instrument, numbers, and functions.
	[MOTOR] Motor input settings	Allows you to configure motor input settings. Shown only when the motor analysis option is installed.
	[FLICKER] Flicker calculation settings	Allows you to configure flicker calculation setting in IEC measurement mode. Shown only when the PW9006 IEC harmonic/flicker measurement function (optional) is installed.

System Settings screen (displayed with the **SYSTEM** key)

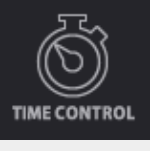
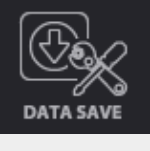
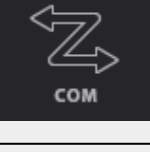
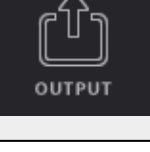
	[CONFIG] System settings	Allows you to review and set up the system environments.
	[TIME CONTROL] Time control settings	Allows you to configure time control settings.
	[DATA SAVE] Data save settings	Allows you to set which items of data to store on a USB flash drive or in the internal memory.
	[COM] Communications settings	Allows you to configure the communications interface.
	[OUTPUT] D/A output settings	Allows you to configure the D/A output settings. Shown only when the waveform and D/A output option is installed.

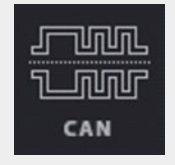
	<p style="text-align: center;">[CAN] CAN settings</p>	<p>Allows you to configure the CAN settings.</p>
---	---	--

File Operation screen (displayed with the **FILE** key)

The File Operation screen is used to manage files on the USB flash drive and to save and load settings files.

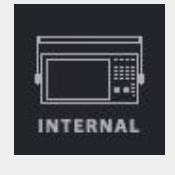
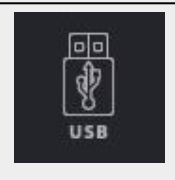
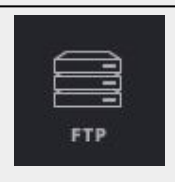
	<p style="text-align: center;">[INTERNAL] Internal memory</p>	<p>You can view data saved to the internal memory and access files and folders.</p>
	<p style="text-align: center;">[USB] USB flash drive</p>	<p>You can view data saved to the USB flash drive and access files and folders.</p>
	<p style="text-align: center;">[FTP] FTP server</p>	<p>You can view connected FTP servers and save files.</p>

1.5 System Architecture

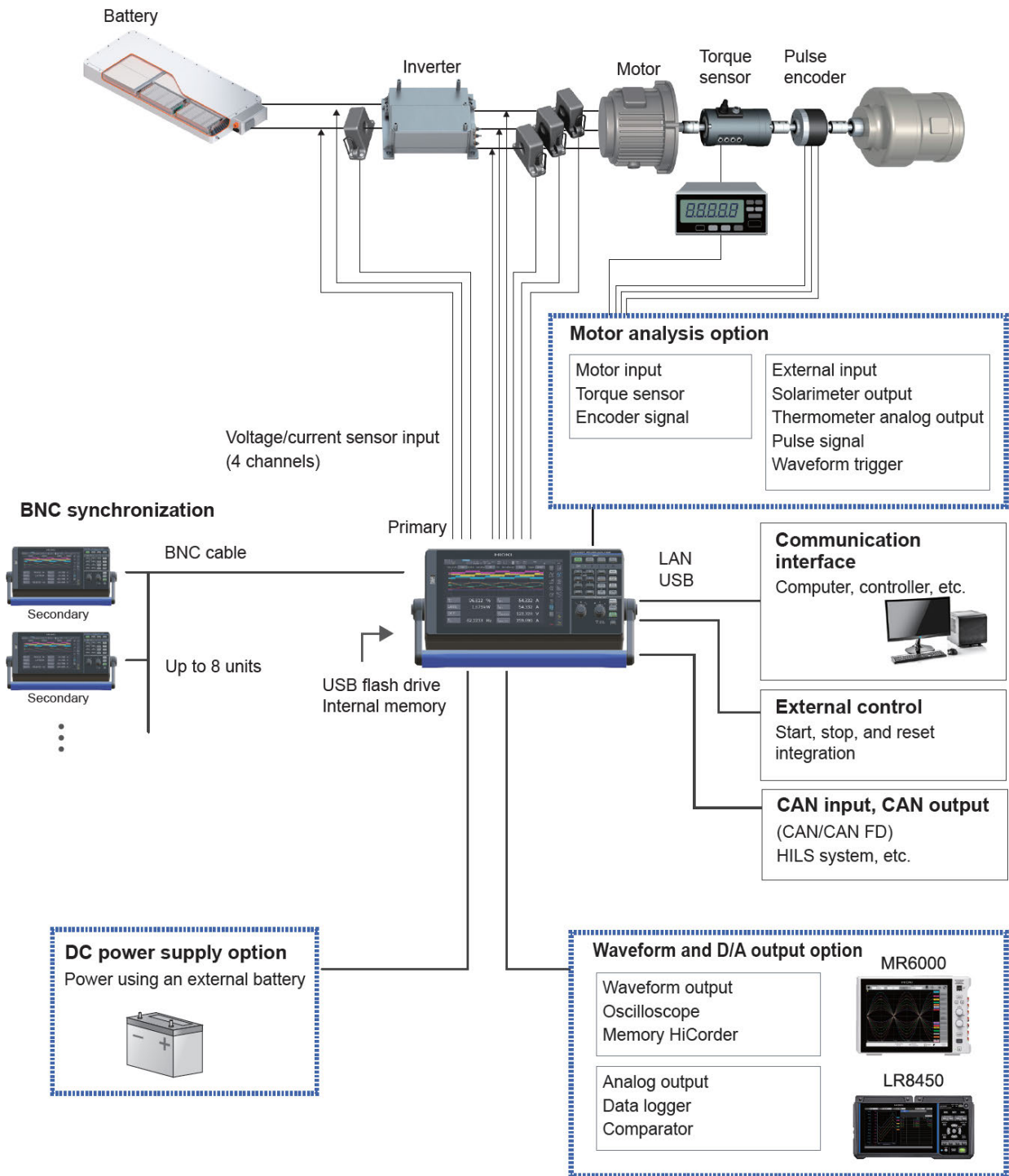

Motor analysis, waveform and D/A output, and the DC power supply are optional.

1.6 Example Measurement Setups

Evaluating the power conversion efficiency of inverters

Isolated inputs for voltage and current (4 channels each) enable power on the primary and secondary sides of the inverter to be measured simultaneously. Noise evaluation is also possible using harmonic analysis.

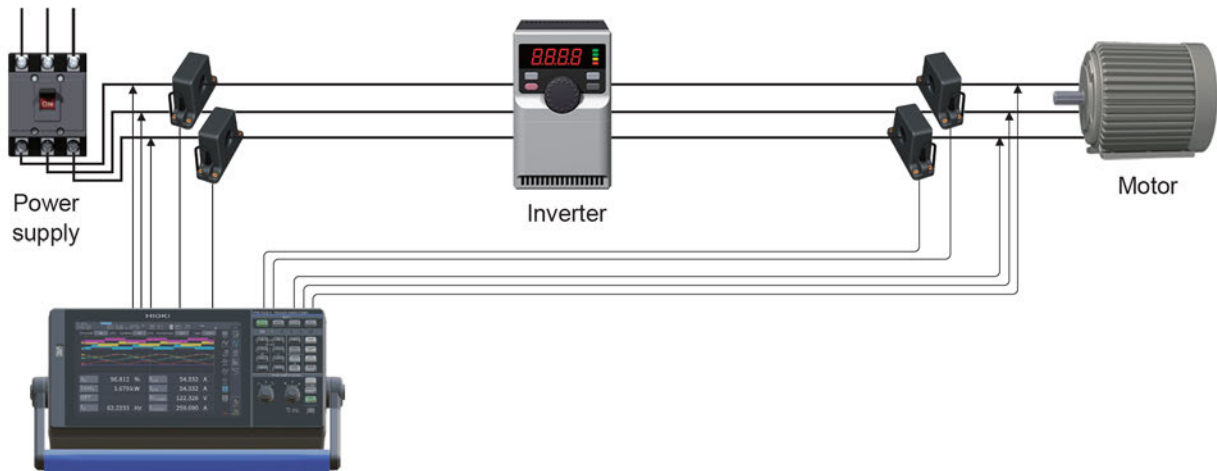

Evaluating the performance of EV and HEV inverter motors

Power can be measured at speeds as fast as 1 ms in transient conditions, such as motor behavior during start and acceleration.

The instrument measures power by automatically following a fluctuating frequency from as low as 0.1 Hz.

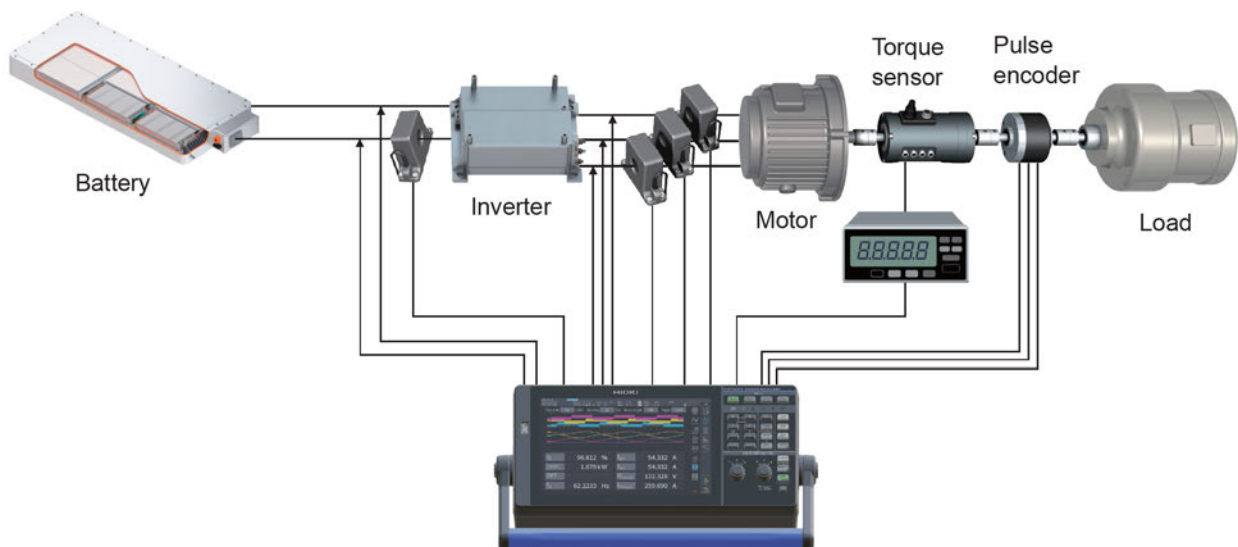

Evaluating the efficiency of PV power conditioners (PCS)

Direct input measurements of up to 1500 V DC (CAT II) are possible for higher voltage PCS. The CT9557 sensor unit enables highly precise measurements of up to 8000 A on lines with multiple wiring.

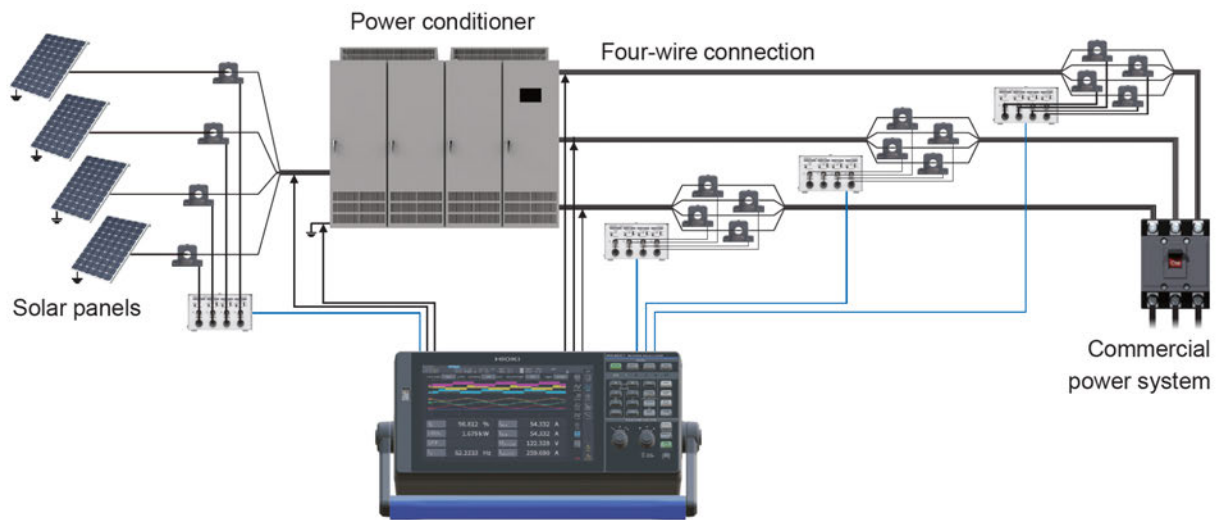

Vehicle fuel efficiency evaluation tests

The instrument can be used in hot or cold environments across a wide temperature range (-20°C to 50°C [-4°F to 122°F]). The instrument also comes standard with a CAN interface, enabling CAN data to be measured simultaneously. For example, power values can be calculated using voltage data on the CAN bus and current values (actually measured values) from a current sensor.

By using the DC power supply option and a separate external battery, power measurements can be made even in situations where commercial power is unavailable, such as during actual road testing.

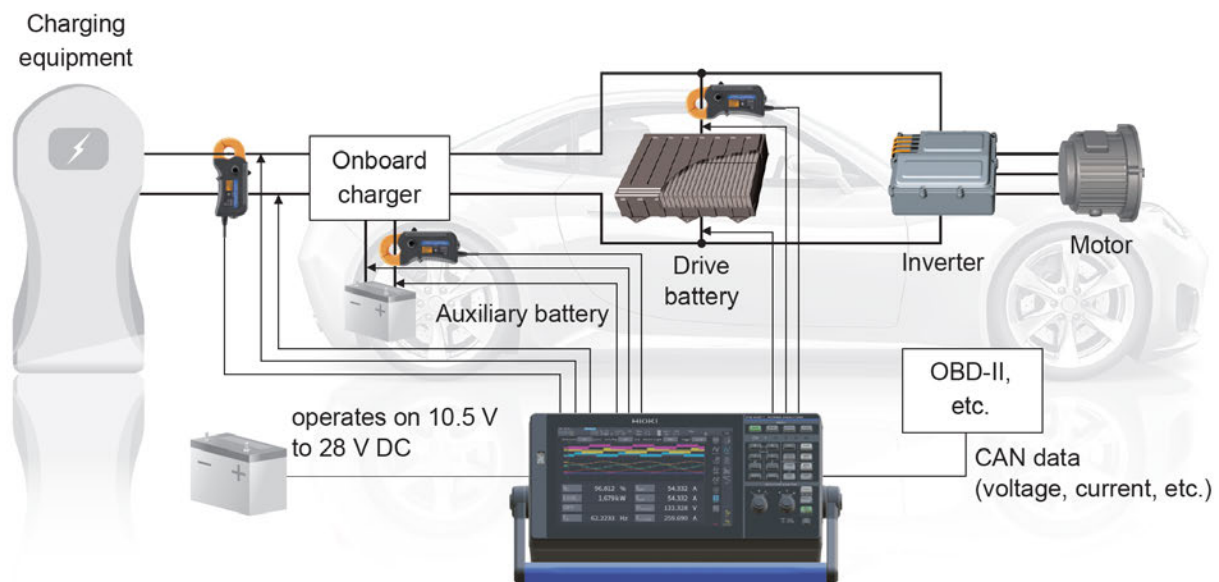

2

Preparing for measurement

The procedure for preparation before measurement is as follows.

- 1** Inspect the instrument before use.
[🔍 See “2.1 Inspecting the Instrument before Use” \(p.52\)](#)
- 2** Connect the voltage cords and current sensors to the instrument.
[🔍 See “2.2 Connecting the Voltage Cords \(Voltage Input\)” \(p.54\)](#)
[🔍 See “2.3 Connecting the Current Sensors \(Current Input\)” \(p.55\)](#)
- 3** Supply power to the instrument.
[🔍 See “2.4 Supplying Power to the Instrument” \(p.60\)](#)
- 4** Set the measurement conditions.
[🔍 See “2.5 Setting Wiring Mode and Configuring Current Sensor Settings” \(p.66\)](#)
[🔍 See “2.6 Simple Configuration \(Quick Set\)” \(p.70\)](#)
- 5** Perform zero adjustment.
[🔍 See “2.8 Zero Adjustment and Degaussing \(Demagnetization\)” \(p.74\)](#)
- 6** Connect the cords and sensors to lines to be measured.
[🔍 See “2.9 Connecting Measurement Leads and Sensors to Lines to Be Measured” \(p.75\)](#)
- 7** Verify proper connection.
[🔍 See “2.10 Checking Connections” \(p.78\)](#)

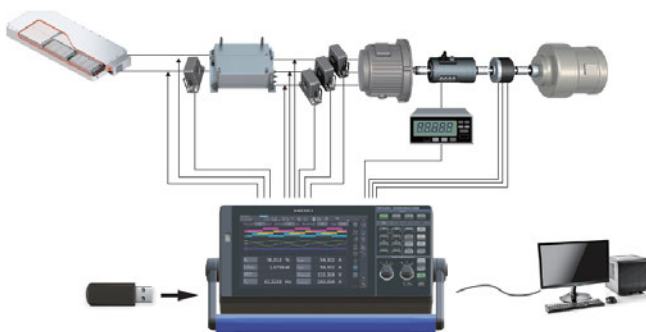

External control

Integration control (Start/Stop/Reset)

[🔍 See “8 Connecting External Devices” \(p.239\)](#)

Communication interface (LAN/USB)

[🔍 See “9 Connecting with Computers” \(p.283\)](#)

Saving data

[🔍 See “7.1 Internal memory” \(p.200\)](#) and [“7.2 USB flash drive” \(p.201\)](#)

2.1 Inspecting the Instrument before Use

Before starting measurement, inspect the instrument, accessories, and options.

DANGER



■ **Check the voltage cord for damaged insulation or exposed metal before use.**



■ **Inspect the instrument and check it for proper operation before use.**

Using a damaged voltage cord or instrument could cause serious bodily injury. If you find any damage on a product, replace it with a Hioki-specified one.

IMPORTANT

The following display languages are available for this instrument. The default language is English.

English (default setting)/Japanese/Simplified Chinese/Traditional Chinese

Select the language you would like to use.

 See "6.1 Checking and Changing Settings" (p.189)

Inspecting accessories and options

Make sure that . . .	Action
Insulation of the power cords and voltage cords is not damaged. No metal is exposed.	If you find any damage, do not use the instrument as the damage may result in an electric shock or short circuit. The instrument will not be able to perform normal measurement in its present state. Please contact your authorized Hioki retailer or reseller.
The current sensors' clamps are not cracked or otherwise damaged.	

Inspecting the instrument

Make sure that . . .	Action
The instrument is not damaged.	If you find any damage, request repair.
The instrument displays [PW4001 POWER ANALYZER] after being turned on. (The self-test is started internally.)	If [PW4001 POWER ANALYZER] is not displayed, the power cord may have a break in it, or the instrument's internal circuitry may be damaged. Please contact your authorized Hioki retailer or reseller.

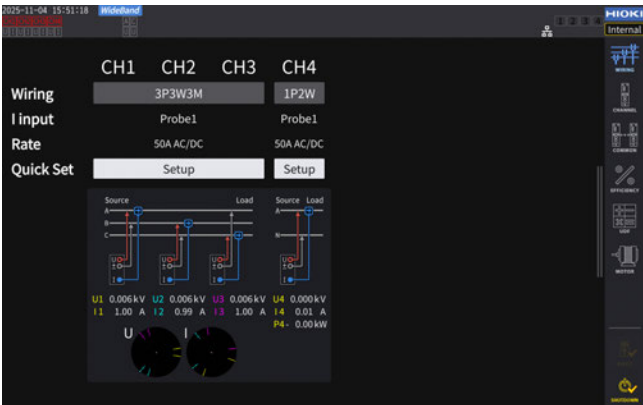
Make sure that . . .	Action
<p>After the self-test is complete, the instrument displays the INPUT key > [WIRING] screen or the screen shown when it was last turned off.</p> 	<p>If the screen is not displayed, the instrument's internal circuitry may be damaged. Please contact your authorized Hioki retailer or reseller.</p>
<p>The instrument's clock is accurate.</p>	<p>If not accurate, set the instrument's clock to the present time. See "6.1 Checking and Changing Settings" (p.189)</p>

2.2 Connecting the Voltage Cords (Voltage Input)

Connect the voltage cords (optional) to the voltage input terminals. Connect as many cords as required based on the lines to be measured and the wiring configuration.

DANGER



- **Do not cause a short circuit between the wire to be measured and another wire with the metallic parts of the tips of the voltage cord.**

Failure to follow this guidance will cause an arc flash, resulting in serious bodily injury or damage to the instrument or other equipment.



- **Check the cables for an exposed white inner insulation layer.**

Using a cable with its inner color layer exposed will result in electric shock.

WARNING

- **Disconnect power to the line under measurement before connecting the test leads.**

Doing so could damage the instrument, resulting in bodily injury.



- **Use only Hioki-specified connection cords with the instrument.**

Failure to follow this guidance could result in bodily injury or a short-circuit fault.

 See “Optional products for voltage measurement” (p.10)

IMPORTANT

To ensure accurate measurement, firmly insert the voltage cords completely.

- 1 Turn off the instrument.
- 2 Insert the red voltage cord or one with the same color as the channel indicator into the U voltage input terminal.
- 3 Insert the black voltage cord into the \pm voltage input terminal.

Rear panel of the instrument

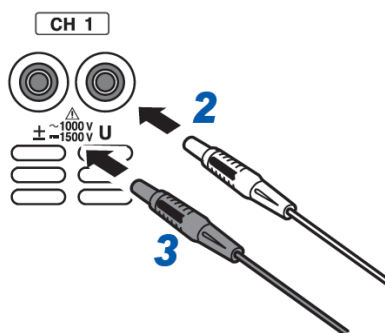

2.3 Connecting the Current Sensors (Current Input)

Connect the current sensor to a current input terminal.

DANGER

- 

■ **Do not use the current sensors to measure an exposed conductor (circuit) carrying a voltage greater than the maximum rated voltage to earth*1.**
Doing so could result in serious bodily injury or a short circuit.

*1 For details about the maximum rated voltage to earth of the current sensor, refer to the instruction manual that came with the current sensor.

- 

■ **Only connect an optional current sensor.**
Using a current sensor other than the optional current sensors could cause serious bodily injury.

WARNING

- 

■ **Turn off all devices before connecting a pass-through-type current sensor of the through type, such as the CT6875.**
There is a risk of the operator experiencing an electric shock. A short circuit may also occur.

CAUTION

- 

■ **Do not connect or disconnect connectors while the instrument has been turned on.**
Doing so could damage the sensor.

IMPORTANT

Certain current sensors have limitations on the number that can be used depending on the usage conditions. Check the specifications of the current sensor to be used and ensure it is operated within the rated current range. Under the following usage conditions, only use a maximum of three CT6877A, CT6876A, or CT6904A series current sensors.

- When using an AC or DC power supply (power supply voltage: 10.5 V to 20 V) and with an operating temperature of 40°C to 50°C (104°F to 122°F)
- When using a DC power supply (power supply voltage: 20 V to 28 V) and with an operating temperature of 30°C to 40°C (86°F to 104°F)

Also, under the above usage conditions, when using a Hioki current sensor that is not a standard option for this instrument, ensure that the total power supply capacity specified in the sensor specifications (consumption current when measuring rated current) does not exceed ± 1200 mA.

 See "Options (Sold Separately)" (p.10)

Connect an optional current sensor. The instrument automatically recognizes current sensors equipped with a memory function.

It also supplies power to the current sensor.

For detailed specifications and instructions for the current sensors being used, refer to the instruction manual that came with the current sensors.

2.3 Connecting the Current Sensors (Current Input)

Rear panel of the instrument

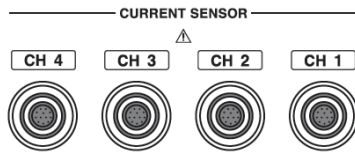

How to connect the connector

When the connector is metallic

- 1** Turn the instrument off, then align the positions of the connector guides of the instrument and the current sensor.
Connect the part of the connector with the large notch (1) is facing upwards.
- 2** Hold the plastic part of the connector and insert it straight until it is locked.
The instrument automatically recognizes the type of the current sensor.

Rear panel of the instrument

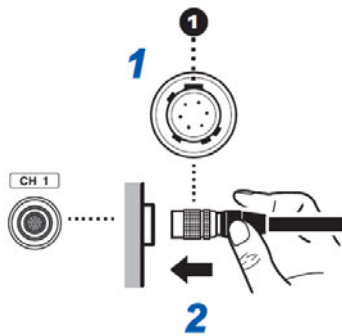

When the connector is plastic

The 9709, CT6860 series, and CT6840 series have current sensors with black plastic connectors. These current sensors can be connected to current input terminals using a CT9900 Conversion Cable.

- 1** Turn the instrument off, then align the positions of the connector guides of the CT9900 Conversion Cable and the current sensor to connect them.
- 2** Insert the connector of the CT9900 straight until it is locked.

Rear panel of the instrument

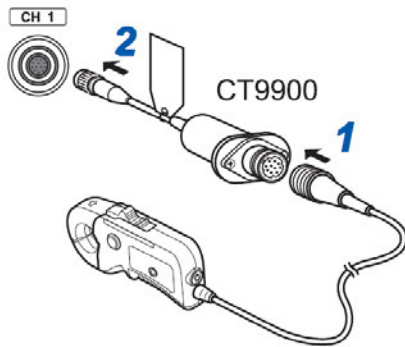

IMPORTANT

When the CT6846 or CT6865 is connected via the CT9900 Conversion Cable, the current sensor is recognized as a 500 A AC/DC sensor. Set the CT ratio to 2.00 in such a case.

[See](#) “Scaling (when using VTs [PTs] or CTs)” (p.97)

How to disconnect the connector

- 1** Hold the metallic part of the connector and slide it toward the cable side to unlock the connector.
- 2** Pull out the connector.

Rear panel of the instrument

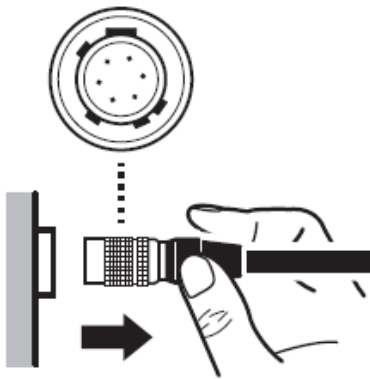

Connecting a CT7000 Series sensor

CT7642, CT7742, CT7044, CT7045, and CT7046 current sensors can be used to measure large currents of 1000 A or more. Connect these current sensors to the instrument using the CT9920 Conversion Cable.

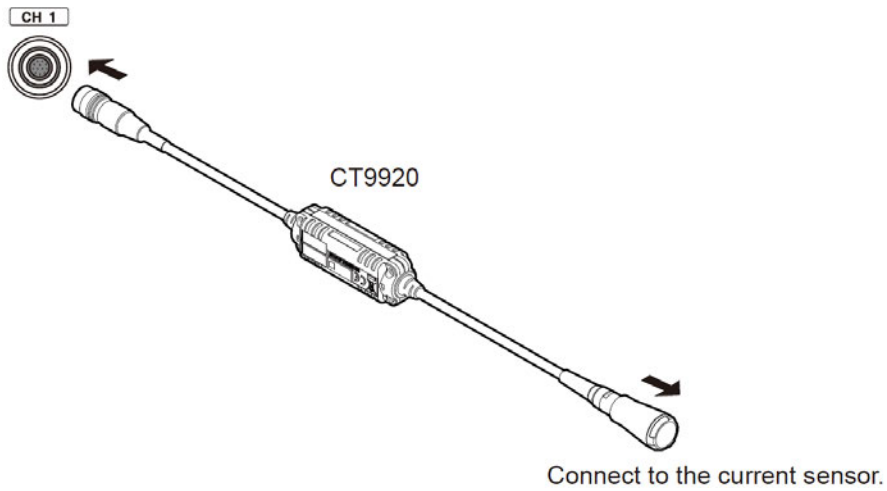

When connecting using the CT9920 Conversion Cable, the rate must be set for the current sensor being used.

[See](#) "2.5 Setting Wiring Mode and Configuring Current Sensor Settings" (p.66)

If the input exceeds the measurable range (using VTs and CTs)

Use instrument transformers: voltage transformers (VTs [potential transformers, PTs]) and current transformers (CTs) externally. VT ratios and CT ratios can be set on the instrument to allow primary-side input values to be read directly.

 See “Scaling (when using VTs [PTs] or CTs)” (p.97)

DANGER



- **Do not touch VT (PT), CT, or the input terminals of the instrument when they are active.**

Doing so could result in serious bodily injury.

WARNING



- **When using VTs (PTs) externally, do not short the secondary side.**

Applying a voltage to the primary side while in the shorted state may cause a large current to flow to the secondary side, resulting in equipment damage or fire.

- **When using CTs externally, do not leave the secondary side open.**

If a current flows to the primary side while in the open state, a high voltage may occur on the secondary side, resulting in a risk of the operator experiencing an electric shock.

IMPORTANT

The phase difference between the external VTs (PTs) and CTs may introduce a large error component into power measurement. If you wish to make more accurate power measurement, use VTs (PTs) and CTs with a small phase error in the frequency band of the circuit being used.

2.4 Supplying Power to the Instrument

The instrument can be powered by a commercial power supply (100 V to 240 V AC) or a DC power supply such as an external battery (10.5 V to 28 V DC, using the DC power supply option).

IMPORTANT

Do not attempt to connect the instrument to both a commercial power supply and DC power supply at the same time.

When using a commercial power supply

DANGER



■ **Use only the specified power cord to provide power to the instrument.**

Using a power cord other than those specified could cause a fire, resulting in serious bodily injury.

WARNING



■ **Connect the power cord to a 3-prong grounded-type (2-pole) power outlet.**

Connecting the power cord to an ungrounded power outlet could result in electric shock.

CAUTION



■ **Do not power the instrument with a power supply that generates a rectangular or pseudo-sine wave, such as an uninterruptible power supply (UPS) or DC/AC inverter.**

Doing so could damage the instrument, resulting in bodily injury. Ensure to use a power supply system with a sine-wave output.

■ **Unplug the power cord while the instrument is not in use.**

Failure to do so could cause the operator to experience an electric shock.

■ **Before plugging the power cord into an outlet, ensure that your supply voltage falls within the supply voltage range indicated close to the power inlet of the instrument.**

Supplying a voltage outside the specified range to the instrument could damage it, causing bodily injury.



■ **Ground the ground terminals of the instrument and the equipment to be connected at a same location.**

Connecting the cable when there is a difference in ground potentials between them could cause damage or malfunction.

Connecting the power cord

- 1 Confirm that the power supply voltage is within the rated range and then connect the power cord to the power inlet. (100 V to 240 V AC)
- 2 Connect the plug of the power cord to the outlet.

When using a DC power supply (DC power supply option)

DANGER



- **When using a battery, connect it in a manner that prevents short circuits.**
Failure to follow this guidance can cause arc flash, resulting in serious bodily injury or damage to the instrument or connected devices.
- **When using a battery, use one with protective components or protection circuits.**
Failure to follow this guidance may result in conditions such as overcurrent or over-discharge that can cause bodily injury or damage to the instrument or connected devices.

WARNING



- **Securely connect the measurement cables to the input terminals.**
Loose terminals could increase contact resistance and cause the instrument to overheat, resulting in bodily injury, instrument burnout, or fire.

CAUTION



- **Securely connect the connection cord to the power supply connector using appropriate wire and tightening torque.**
Failure to follow this guidance may result in a malfunction or damage to the instrument or connected devices.
- **Before connecting the instrument to a DC power supply, ensure that the supply voltage falls within the supply voltage range indicated close to the power inlet of the instrument and that the polarities (+, -) are correct.**
Failure to follow this guidance may result in damage to the instrument or connected devices.
- **Use the function ground terminal for the instrument and the devices being connected.**
When using on a vehicle, etc., make sure to connect with the body ground.
Failure to follow this guidance may result in a malfunction or damage to the instrument or connected devices.
- **Ensure that no force is applied to the power supply connector.**
Particularly in environments subject to vibration, secure the wires so that no stress is applied.
Failure to follow this guidance may result in a malfunction or damage to the instrument or connected devices.
- **When disconnecting the power supply connector from the instrument, first turn off the power and then pull it out by holding the power supply connector itself.**
Failure to follow this guidance may result in damage to the connection cord or breakage of the power supply connector.

IMPORTANT

The DC power supply voltage that can be provided will vary depending on the operating temperature.

- 10.5 V to 28 V DC (Operating temperature range: -20°C to 40°C (-4°F to 104°F))
- 10.5 V to 20 V DC (Operating temperature range: 40°C to 50°C (104°F to 122°F))

Connecting the power supply connector

Tools to be prepared

DC power supply (battery, etc.)	Power supply voltage: 10.5 V to 28 V DC (Operating temperature range: -20°C to 40°C (-4°F to 104°F)) 10.5 V to 20 V DC (Operating temperature range: 40°C to 50°C (104°F to 122°F))
Power supply connector (accessory)	Model number: PC 4/2-ST-7.62 (Phoenix Contact)
Connection cord	Single wire: 1.25 mm ² to 4 mm ² (AWG16 to AWG12) Stranded wire: 1.25 mm ² to 4 mm ² (AWG16 to AWG12) Recommended bare wire length: 7 mm
Wire (for function grounding)	Crimp terminal: M4 screw type
Phillips screwdriver (M4)	
Flat-head screwdriver (M3)	

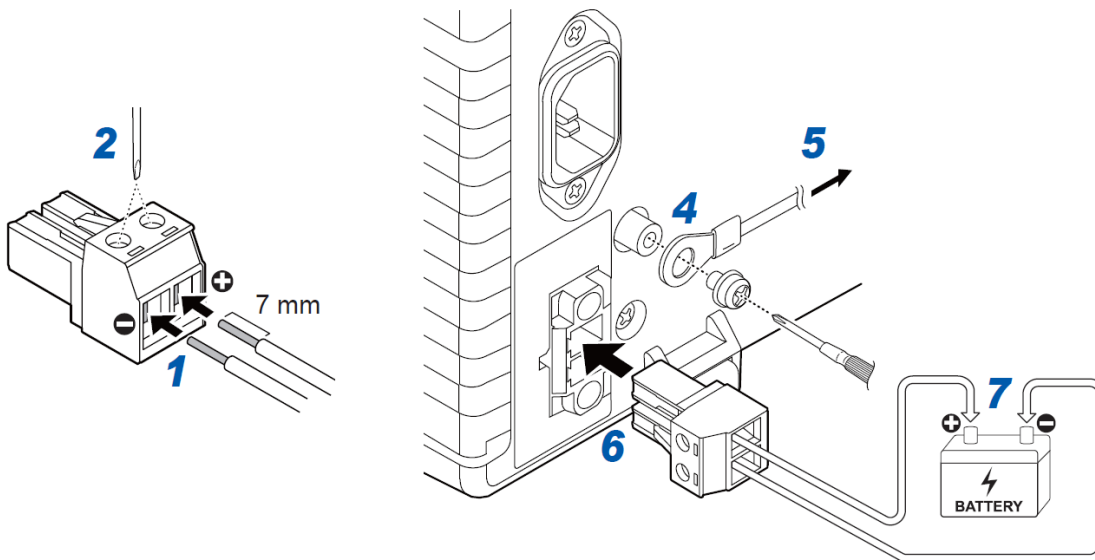

- 1** Connect the connection cord to the power supply connector.
Fully insert the connection cord and connect it so that all core wires are inside the connector.
- 2** Tighten the screws of the power supply connector with a flat-head screwdriver (M3).
Tightening torque: 0.5 N•m to 0.6 N•m
- 3** Gently pull on the connection cord to confirm that it does not become disconnected.

IMPORTANT

- Make sure the polarities are correct when connecting.
- The screws of the power supply connector are electrically connected to the terminal. Before handling the screws, disconnect the connection cord from the DC power supply.
- Periodically retighten the screws of the power supply connector.

- 4 Connect the wire to the function grounding terminal of the instrument and secure it with a Phillips screwdriver (M4).

Tightening torque: 1.2 N•m to 1.3 N•m

- 5 Connect the wire to the ground.

Connect it to a nearby grounding point.

IMPORTANT

When using on a vehicle, make sure to connect with the body ground.

- 6 Connect the power supply connector to the instrument.

Make sure the connector orientation is correct when connecting.

- 7 Connect to the DC power supply used to supply power. When using a battery, connect the positive terminal (+) to the positive wire of the connection cord, and the negative terminal (-) to the negative wire of the connection cord.

IMPORTANT

- This instrument does not have a battery charging function.
- The instrument will automatically stop power from being supplied from the +12 V battery if the voltage falls outside the rated supply voltage range (9.0 V to 10.5 V) due to over-discharge, etc. Once stopped, it will not restart even if the power supply voltage returns to around +12 V. To restart, first stop the supply of power by means such as disconnecting connection cord from the +12 V battery before attempting to supply power again.

Turning the instrument on

1 Connect the voltage cords, current sensors, and power cord (or power supply connector).

2 Press the power key.

The instrument is turned on and starts a self-test (self-diagnosis by the instrument, approx. 10 s). Once the self-test is finished, the Input screen's **[WIRING]** page will be displayed (default setting). If the startup screen is set to **[LAST]**, the screen when the instrument was last turned off will be displayed.

🔍 See "2.1 Inspecting the Instrument before Use" (p.52)

3 Warm up for 30 minutes or longer.

IMPORTANT

- Perform warm up in an environment of between 0°C and 50°C (32°F and 122°F).
- For high-precision measurement, warm up for 60 minutes or longer.

4 Perform the zero adjustment.

🔍 See "2.8 Zero Adjustment and Degaussing (Demagnetization)" (p.74)

IMPORTANT

If the instrument malfunctions, a dialog box will appear and operation will be restricted. The instrument is faulty if the dialog box appears again after power has been restarted. Perform the following procedure before contacting your authorized Hioki retailer or reseller.

1. Stop measurement, shut off power to the lines under measurement or disconnect the voltage cords and current sensors from the lines under measurement, and turn off the instrument.
2. Disconnect the power cord and all measurement leads and sensors.

Turning the instrument off

CAUTION



■ **Remove the voltage cords and the current sensors from the lines to be measured before turning off the instrument.**

Failure to do so could damage the instrument.

1 Press the power key. Or, tap **[SHUTDOWN]** at the lower right of the screen.

The confirmation window is displayed.

2 Tap **[Yes]** to shut down the instrument.

The instrument enters the following state during the shutdown process:

- The fan inside the instrument keeps rotating.
- The **MEAS**, **INPUT**, **SYSTEM**, and **FILE** keys light up simultaneously.

IMPORTANT

The following standby power will be consumed even after shutting down the instrument using the power key. When not in use, unplug the power cord and power supply connector.

Commercial power supply: Approx. 4.2 W

DC power supply: Approx. 1.0 W

2.5 Setting Wiring Mode and Configuring Current Sensor Settings

This section describes how to set wiring modes based on the number of channels with which the instrument is equipped and the lines to be measured.

For measurement on multi-phase systems, connect the same current sensors to all the channels to be combined.

Display screen: **INPUT** key > **[WIRING]**

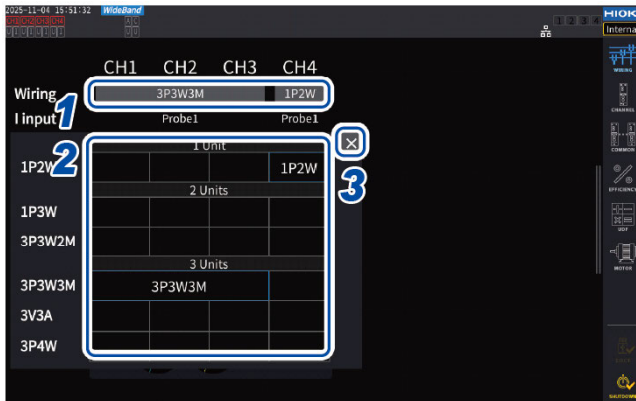

1 Tap the button to select a wiring mode for each channel.
The Settings window will open.

2 Select a wiring mode from among 1 module, 2 modules, and 3 modules.

Q See “Wiring diagrams” (p.76)

When different types of input modules are connected to a single wiring configuration, the circumference of the wiring button is displayed in yellow.

3 Tap **[X]** to close the Settings window.

Rates can be individually selected when using the CT9920.

4 (When using the CT9920) Tap the rate-selection button and then select the rate of the connected current sensor.

Select 0.1 mV/A when using the CT7642, CT7742, CT7044, CT7045 or CT7046.

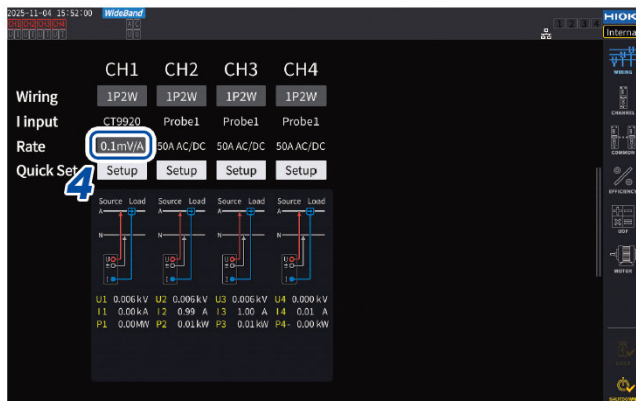

IMPORTANT

When using a current sensor whose rating can be switched, match the rating of current sensors in the same line. If a wiring pattern using multiple channels is selected, the parameters that can be set for each channel (such as the voltage range) are unified to those of the first channel.

Wiring mode

1P2W (Single-phase 2-wire)	Select this wiring mode when measuring a DC line. The current sensor can be connected to either the source or ground terminal. The wiring diagrams include examples of both. Q See "Wiring diagrams" (p.76)
1P3W (Single-phase 3-wire)	-
3P3W2M (3-phase 3-wire)	Select this wiring mode when using the two-wattmeter method with two channels to measure a three-phase delta configuration. It enables accurate measurement of active power even when waveforms are distorted due to an unbalanced state. Apparent power, reactive power, and power factor values for unbalanced lines may differ from corresponding values obtained from other measuring instruments. In such a case, use 3V3A or 3P3W3M wiring mode.
3V3A (3-phase 3-wire)	Select this wiring mode when using the two-wattmeter method with three channels to measure a three-phase delta configuration, which is used when you emphasize compatibility with legacy power meters such as the Hioki 3193. It allows accurate measurement of not only active power, but also apparent and reactive power and power factor even with unbalanced lines.
3P3W3M (3-phase 3-wire)	Select this wiring mode when using the three-wattmeter method with three channels to measure a three-phase delta configuration. It allows accurate measurement even if the instrument in 3V3A wiring mode yields an error due to leakage current with large high-frequency component when measuring a PWM inverter, making it well suited to motor power measurement.
3P4W (3-phase 4-wire)	Select this wiring mode when using the three-wattmeter method with three channels to measure a three-phase Y (star) configuration.

Current sensor auto-recognition function

The instrument automatically acquires the rated current, phase compensation values, and other information of the current sensor connected to the instrument.

This function can significantly reduce the setting time before measurement, and measure the power based on accurate sensor information.

(Only current sensors with the auto-recognition function)

In the following cases, the instrument automatically acquires only the rated current of the current sensor connected to the instrument.

- When a current sensor not equipped with the auto-recognition function is connected to the instrument
- If the instrument fails to read current-sensor information, including phase compensation values

List of optional current sensors

[Q See "Optional products for current measurement" \(p.11\)](#)

Compensating for phase errors of current sensors

Current sensors generally exhibit a tendency for phase error to increase gradually in the high-frequency region of their frequency band. By using sensor-specific phase characteristics information to correct the measured values, it is possible to reduce the error component in power measurement made in a high-frequency region.

Conceptual diagram

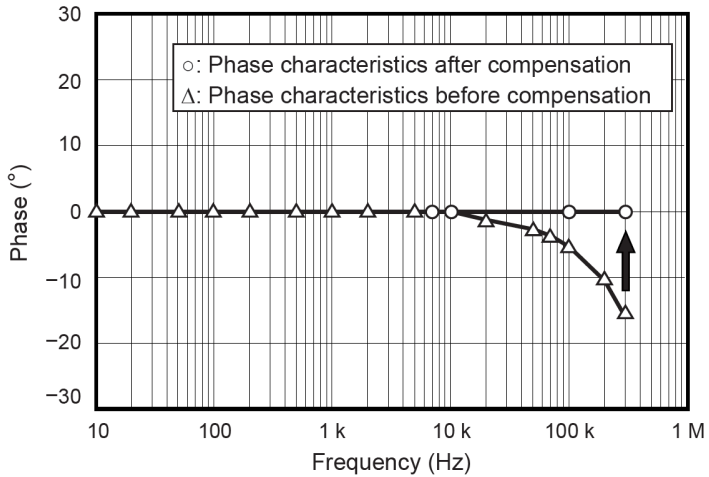

Phase compensation of current sensors with auto-recognition function

When using a current sensor with the auto-recognition function, the phase of the current sensor is automatically corrected. If you wish to set any phase compensation values, follow the steps listed in the following “How to enter phase compensation values” section.

How to enter phase compensation values

If using current sensors without the auto-recognition function, measure after performing phase compensation for the current sensors.

Display screen: **INPUT** key > **[CHANNEL]**



1 Tap the detailed display area for the channel to be configured.

2 Tap the **[Phase Shift]** area box and select **[ON]**.

When using a current sensor equipped with the auto-recognition function, **[Auto]** is displayed as an alternative.

When **[Auto]** is selected, the compensation values are entered automatically.

3 Tap the frequency box, then enter the frequency with the numeric keypad.

4 Tap the phase difference box, then enter the phase difference with the numeric keypad.

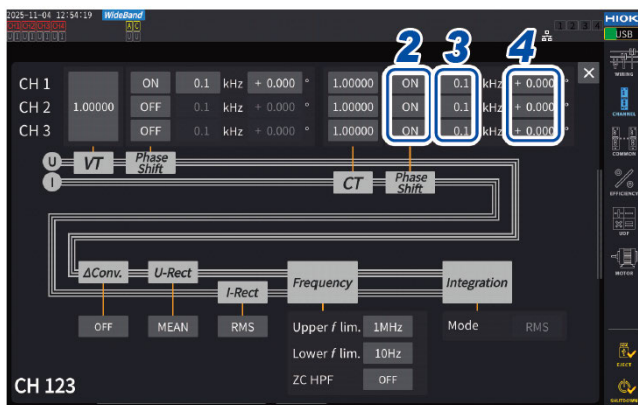

IMPORTANT

- Enter the phase compensation value accurately. Mistaken settings can cause the compensation process to increase measurement error.
- Operation outside the frequency range within which the current sensor's phase accuracy is specified is not defined.

Typical values of current sensors' phase characteristics

You can find typical values of current sensors' phase characteristics on Hioki's website.

- 1 Open the PW4001 product page on <https://www.hioki.com>.
- 2 Open the **[User's Guide]** tab under **[Downloads]**.
- 3 Select **[Typical Values of Current Sensors' Phase Characteristics]**.

For the phase characteristics information when using CT9557, please contact your authorized Hioki retailer or reseller.

2.6 Simple Configuration (Quick Set)

The measurement conditions are set to the representative values according to the selected lines to be measured. This functionality is useful when you are using the instrument for the first time or when you need to measure lines that differ from those measured last.

Display screen: **INPUT** key > **[WIRING]**



- 1 Tap **[Setup]** in the **[Quick Set]** box.
- 2 Touch the type of the line to be measured to select it from the list.
The confirmation window is displayed.
- 3 Tap **[Yes]** to accept the setting.
- 4 Check the setting details via the **INPUT** key > **[CHANNEL]** screen.
Change the settings as necessary.



Types of lines under measurement

50/60 Hz	Select this type to measure a commercial power line over a broad range of frequencies.
DC/WLTP	Select this type to measure DC line over a broad range of frequencies. The settings are suitable for measuring the charging/recharging cycle of a battery or a DC line, specified in the worldwide harmonized light vehicles test procedure (WLTP). When making measurement in conformity with WLTP, set the data update interval at 50 ms or less. This setting is selectable only in 1P2W wiring mode.
PWM	Select this type to measure a PWM line. A fundamental frequency of 1 Hz to 1 kHz is used so that it does not synchronize with the carrier frequency of 1 kHz or more. It is recommended to use the sensor phase compensation function to facilitate more accurate measurement.
HIGH FREQ	Select this type to measure a high-frequency source with a frequency of at least 10 kHz. It is recommended to use the sensor phase compensation function to facilitate more accurate measurement.

GENERAL	Select this type to measure lines other than the [50/60Hz] , [DC/WLTP] , [PWM] , or [HIGH FREQ] type. Also use this setting when the object under measurement is not well known. It is recommended to use the sensor phase compensation function to facilitate more accurate measurement.
----------------	---

Setting details

Wiring configuration to be measured	Synchronization source	Voltage range	Current range	Upper frequency limit	Lower frequency limit	Integration mode	U/I rectification method	LPF
50/60 Hz	Voltage	Auto	Auto	100 Hz	10 Hz	RMS	RMS/RMS	OFF
DC/WLTP	DC	Auto	Max. range	100 Hz	10 Hz	DC	RMS/RMS	OFF
PWM	Voltage	Auto	Auto	1 kHz	1 Hz	RMS	MEAN/RMS	OFF
HIGH FREQ	Voltage	Auto	Auto	1 MHz	1 kHz	RMS	RMS/RMS	OFF
GENERAL	Voltage	Auto	Auto	1 MHz	0.1 Hz	RMS	RMS/RMS	Off

2.7 Measurement mode

Select a measurement mode.

Display screen: **INPUT** key > **[COMMON]**

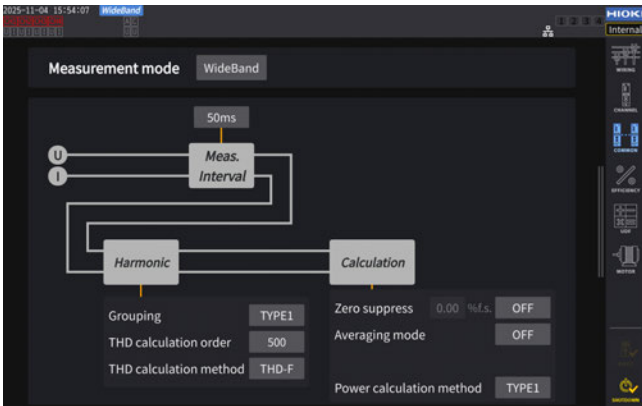

Tap the **[Measurement mode]** box and select a measurement mode.

IEC	<p>Select to use IEC measurement mode.</p> <p>This mode can only be selected when the PW9006 IEC harmonic/flicker measurement function (optional) is installed. When the measured line has a frequency of 50 Hz or 60 Hz, the instrument performs harmonic measurement that complies with the IEC 61000-4-7 standard and voltage fluctuation/flicker measurement that complies with the IEC 61000-4-15 standard. Harmonic measured values will be updated at intervals of 200 ms. Accurately measured values for harmonic measurement and voltage fluctuation/flicker measurement cannot be guaranteed if the frequency to be measured falls outside the range of 45 Hz to 66 Hz. Analysis can be performed up to the 200th order.</p>
WideBand	<p>Select to use wideband measurement mode.</p> <p>It can be used with a wide range of frequencies from 0.1 Hz to 600 kHz. The analysis order varies with the frequency being measured. When the data update interval is set at 10 ms or less, measured harmonic values will be updated at intervals of 50 ms.</p>

- Settings cannot be switched on a wiring configuration or channel basis.
- The same synchronization source will be used for each channel's harmonic measurement. Note, however, that if **[Zph1]** is selected as the synchronization source and **[Ext1]** is selectable, either **[Ext1]** or **[Zph1]** is selectable as the synchronization source for harmonic measurement.
🔍 See "Synchronization source" (p.91)
- Accurate harmonic measurement is not possible if the frequency of the input signal set as the synchronization source fluctuates or if the input signal exhibits a low level relative to the range.

In IEC measurement mode, internal calculation processing differs from the regular measurement mode to realize measurements in compliance with the IEC standard. Thus, some functions are restricted in IEC measurement mode.

Data update interval	Fixed at 200 ms
-----------------------------	-----------------

Data outputting interval	100 ms or more
Synchronization source	Only U and I are selectable
Upper frequency limit	Fixed at 100 Hz
Lower frequency limit	Fixed at 10 Hz
HPF	Fixed to OFF
Average Mode	Only OFF or exponential averaging* ¹ can be selected
Exponential average response speed	No options available
Harmonic analysis order	Up to 200th order
Integration	Fix to integration for all channels
Integration operation	Cumulative integration is not possible (restating from the current integrated value is not possible after stopping integration)
Simple settings	Only 50 Hz and 60 Hz

*1 When exponential averaging is selected, averaging is performed to be equivalent to a first-order low-pass filter with a time constant of 1.5 s in accordance with the IEC 61000-4-7 standard.

2.8 Zero Adjustment and Degaussing (Demagnetization)

Before connecting the instrument, perform zero adjustment while no voltage or current is inputted. Zero adjustment is performed for all ranges and for all input channels at the same time. In addition, if a current sensor that can measure both AC and DC currents is connected to the instrument, the current sensor will be degaussed (demagnetization, DMAG) at the same time.

- 1 Connect the current sensors and voltage cords to the instrument.

Adjustment of measured current values must include the current sensors.

- 2 Allow the instrument to warm up for 30 minutes or more while it has been turned on.

- 3 When zero adjustment can be performed on the current sensor connected to the instrument, perform zero adjustment on the current sensor side.

Some current sensors may have an element, such as a knob, to perform zero adjustment.

See the Instruction Manual of the current sensor. If it contains any instructions regarding connecting to equipment with a zero correction function, follow them.

- 4 Set wiring modes and configure current sensor settings.

- 5 Press the **MEAS** key.

If Ch. 1 through Ch. 4 are lit up, zero adjustment will be performed for voltage and current.

(When equipped with the motor analysis option) If the **[A-D]** channel indicators are lit up, zero adjustment will be performed for the motor input channels.

- 6 Press the **0ADJ** key.

A confirmation dialog box is displayed.

- 7 Tap **[Yes]**.

The screen will display **[Performing zero adjustment...]** and the process will be completed in about 30 s.



- 8 Connect the sensor and leads to the lines to be measured.

2.9 Connecting Measurement Leads and Sensors to Lines to Be Measured

Perform zero adjustment and then connect voltage cords and current sensors to lines to be measured as indicated in the wiring diagram shown via the **INPUT** key > **[WIRING]** screen. To ensure accurate measurement, connect the instrument exactly as shown on the wiring diagram.

The wiring diagram will be displayed when you select a wiring mode via the **INPUT** key > **[WIRING]** screen.
 🔍 See “2.5 Setting Wiring Mode and Configuring Current Sensor Settings” (p.66)

Voltage Cord

Firmly clip the voltage cords to the metallic parts on the power supply side, such as screws and bus bars.

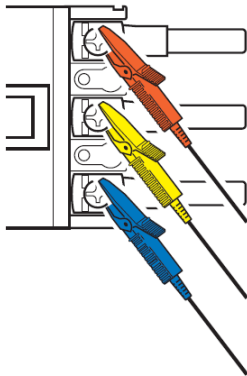

Current sensors

Clamp the current sensor around a conductor so that its current direction mark points at the load side.

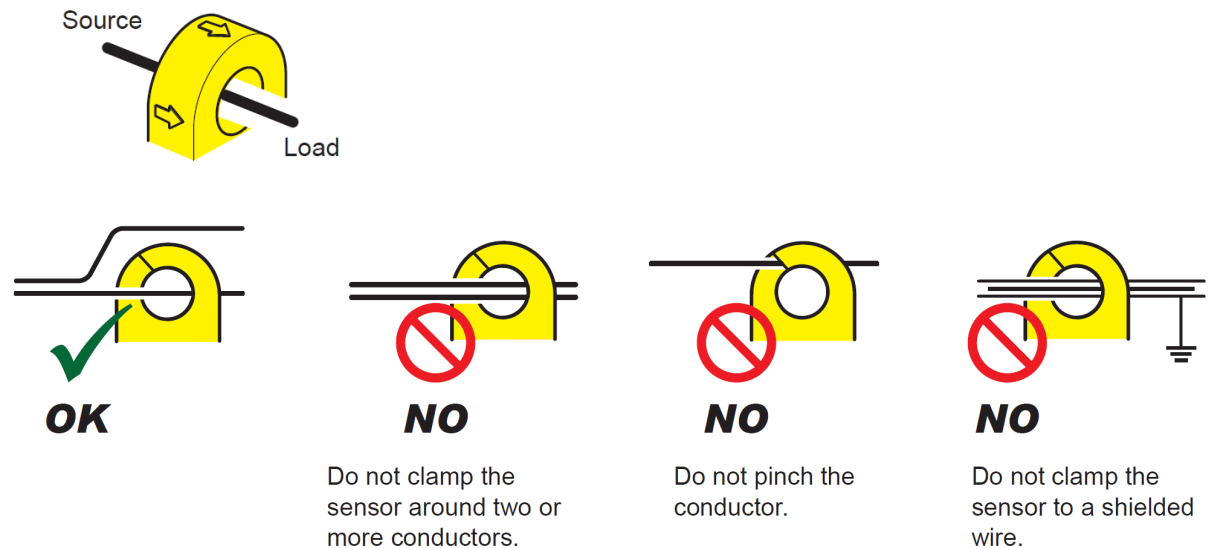

IMPORTANT

- The phases are labeled as A, B, C on the wiring diagram screen. Connect the instrument based on whatever names you are using, such as R/S/T and U/V/W, as appropriate.
- Ensure the current sensor is clamped around only one wire of the conductors. Regardless of whether it is the single-phase or three-phase, clamping the instrument around two or more wires together in a bundle will prevent accurate measurement of the current.

Wiring diagrams

Single-phase 2-wire (1P2W)

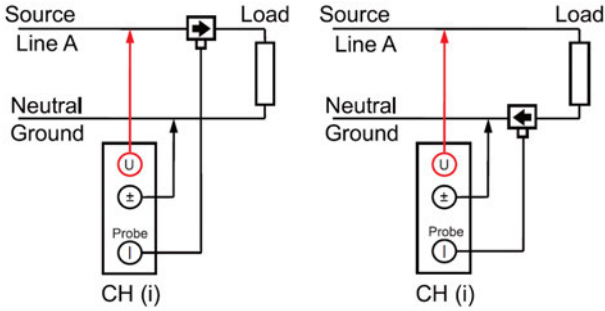

Single-phase 3-wire (1P3W)

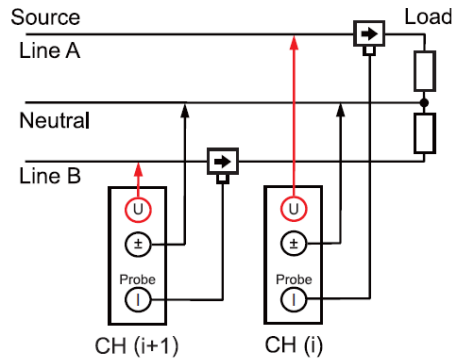

3-phase 3-wire (3P3W2M)

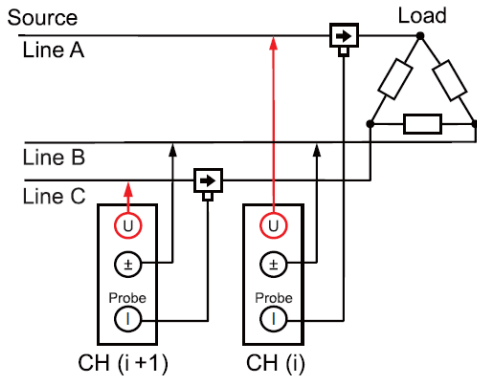

3-phase 3-wire (3V3A)

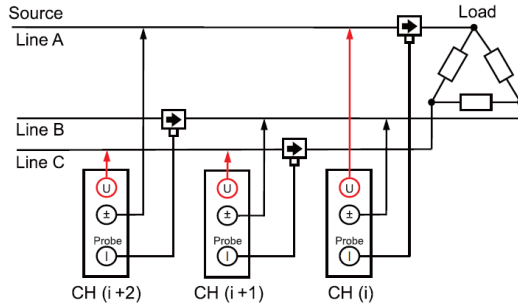

3-phase 3-wire (3P3W3M)

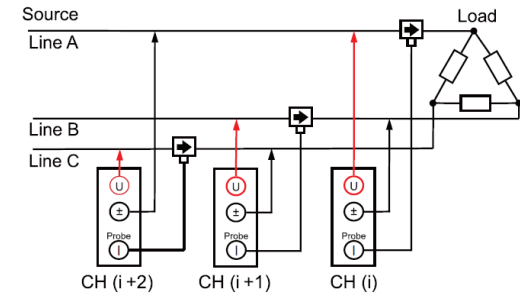

3-phase 4-wire (3P4W)

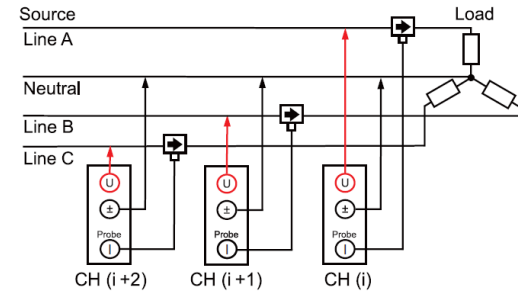

Normal connection when using the PW9100A

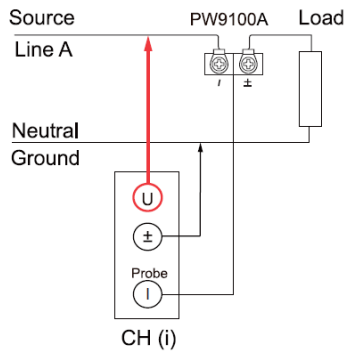

When the PW9100A and either PT or CT are used

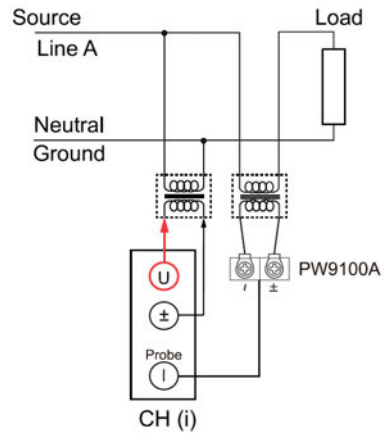

2.10 Checking Connections

Based on the measured values and vectors on the screen, you can check whether the voltage cords and the current sensors are connected properly.

Display screen: **INPUT** key > **[WIRING]**

1P2W mode

When the cords and sensors are properly connected, the measured values are displayed.

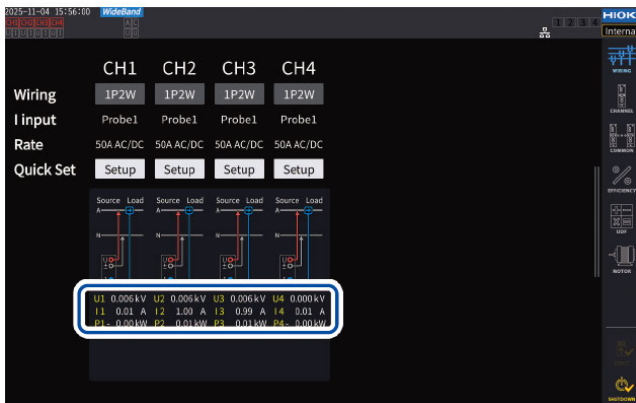

Wiring mode other than 1P2W mode

The measured values and vector lines are displayed. When the cords and sensors are properly connected, the vector lines indicates the proper range.



- The vector lines are shown in the same colors as those of measured values' items.
- The indication range used in vector diagrams assumes an inductive load (such as a motor).
- Vectors may exit the range when the power factor approaches zero or when a capacitive load is measured.
- The measured value of active power P for individual channels may be negative for 3P3W2M and 3V3A lines.

Issue	Cause
The measured voltage value is too high. The measured voltage value is too low.	<ul style="list-style-type: none"> • The voltage cord connectors have insufficiently been inserted into the instrument's voltage input terminals. • The voltage cords have improperly been connected to the lines under measurement.

Issue	Cause
The measured current value is not appropriate.	<ul style="list-style-type: none"> The current sensor connectors have insufficiently been inserted into the instrument's current sensor input terminals. The current sensors have improperly been connected to the lines under measurement.
The measured active power value is negative.	<ul style="list-style-type: none"> The voltage cords have improperly been connected to the lines under measurement. The current sensors' current direction mark (arrow) have not pointed at the load side but the source side.
The active power is not displayed. (Zero is displayed.)	<ul style="list-style-type: none"> The zero suppress setting is not set to off.
The vector arrow is too short. Or, the vector lengths differ.	For voltage vectors <ul style="list-style-type: none"> The voltage cords have improperly been connected to the lines under measurement.
	For current vectors <ul style="list-style-type: none"> The current sensors have improperly been connected to the lines under measurement. The connected current sensors are inappropriate for currents flowing through the line under measurement. The [Sync. source] setting has been set improperly.
The vector direction (phase) and color differ.	<ul style="list-style-type: none"> The voltage cords and current sensors have been connected to the inappropriate terminals.

🔍 See “2.2 Connecting the Voltage Cords (Voltage Input)” (p.54)

🔍 See “2.3 Connecting the Current Sensors (Current Input)” (p.55)

🔍 See “2.9 Connecting Measurement Leads and Sensors to Lines to Be Measured” (p.75)

2.10 Checking Connections

3 Displaying Power Numerically

All measured data is displayed on the Measurement screen.
 If the **MEAS** key does not light up, press the **MEAS** key to activate the Measurement screen.

3.1 Displaying Measured Values

Basic screen

The basic screen displays the measured values of the selected channel.

Display screen: **MEAS** key > **[VALUE]** > **[BASIC]**

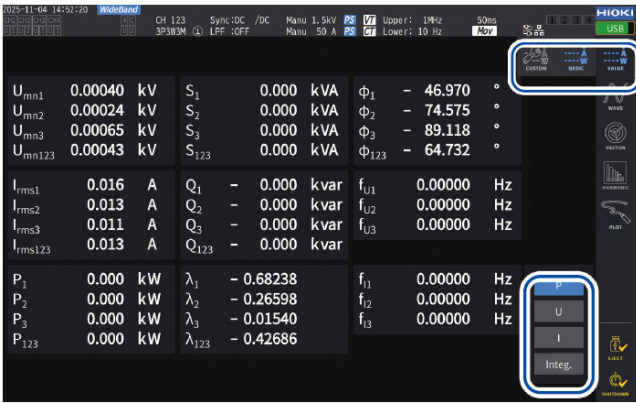

1 Select the measured values to display.

P	Measured power value (p.84)
U	Measured voltage value (p.85)
I	Measured current value (p.85)
Integ.	Integrated measured value (p.98)

2 Switch the channel to be displayed using the **◀ CH ▶** keys for channel selection.

Custom screen

The custom screen allows you to select necessary parameters from all the basic measurement parameters being measured and display them on a single screen.

Display screen: **MEAS** key > **[VALUE]** > **[CUSTOM]**

8-parameter display



16-parameter display



3.1 Displaying Measured Values

36-parameter display



64-parameter display

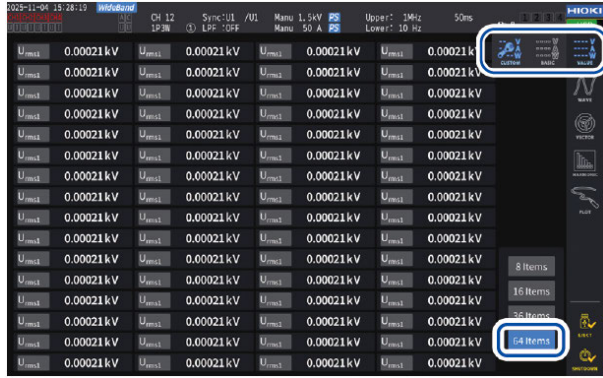

Display item settings

Display screen: **MEAS** key > **[VALUE]** > **[CUSTOM]**

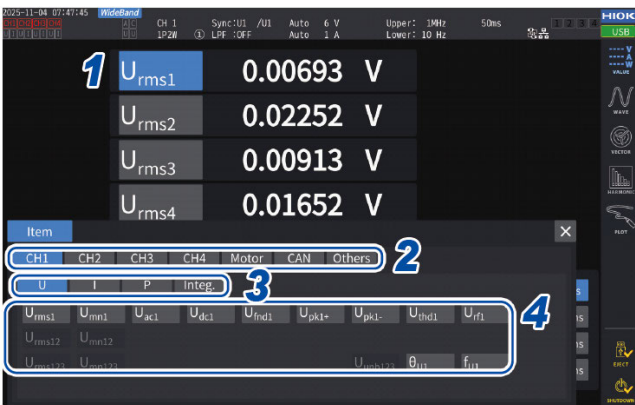

- 1 Tap the item name box to open the settings window.
- 2 Tap a channel to select it.

Ch. 1 to Ch. 4	Basic measurement items
Motor	Motor analysis item
Others	Items to be set using equations

- 3 For Ch. 1 to Ch. 4, tap **[U]**, **[I]**, **[P]**, **[Integ.]**, or **[Flicker]***1.
- *1 Shown when the PW9006 IEC harmonic/flicker measurement function (optional) is installed.
- 4 Tap an item from the displayable-item list to select it.

Effective measurement range and displayable range

In general, the instrument's effective measurement range (the range in which measurement accuracy is guaranteed) is 1% to 110% of the measurement range. The instrument's displayable range is up to 0% to 150% of the measurement range (up to 135% for the 1500 V range).

See "10.4 Detailed Specifications of Measurement Parameters" (p.358)

Exceeding either of these ranges will trigger the following display, which indicates an overload condition occurs.



The value display area will be left blank when **[OFF]** is selected as the display parameter or when the setting is such that the selected item becomes invalid.

Example: Selecting P123 while using the 3P4W setting and then reverting the wiring mode to 1P2W so that P123 is invalid.



If the input level is less than 0.01% to 1.00% of the measurement range, the measured value remains zero. Set the zero suppress setting to OFF to display to a lower level.

Displayed items

The value calculated as the overall value of the measured values of two or more channels is displayed as follows.

U_{rms123}	Averaged voltage RMS value of the three phases
I_{rms123}	Averaged current RMS value of the three phases
P_{123}	Sum of power RMS values of the three phases

🔍 See “10.5 Specifications of Equations” (p.375)

3.2 Measuring Power

The basic screen is used to view measured power values for each lines under measurement. The screen provides functions for listing measured power values for each specified wiring configuration and displaying measured voltage and current values in detail.

You can change the on-screen channels using the channel-selection keys as well as the voltage and current range.

Press the **MEAS** key, tap **[VALUE]** > **[BASIC]**, and then select the basic screen.

Select **[P]** (power screen), **[U]** (voltage screen), **[I]** (current screen), or **[Integ.]** (integration screen) from the screen icons.

Displaying measured power values

Display screen: **MEAS** key > **[VALUE]** > **[BASIC]**



1 Tap **[P]**.

2 Switch the channel to be displayed using the **◀ CH ▶** keys for channel selection.

Urms	Voltage RMS value
Irms	Current RMS value
P	Active power
S	Apparent power
Q	Reactive power
λ	Power factor
∅	Power phase angle
fU	Voltage frequency
fI	Current frequency

- Depending on the rectification setting, mean-value rectified RMS equivalent values (mean values) will be displayed in the voltage RMS value (Urms) and current RMS value (Irms) display areas.
[See "Rectification method" \(p.96\)](#)
- Polarity signs for power factor (λ), reactive power (Q), and power phase angle (\emptyset) indicate the lead/lag polarity, with no sign indicating lag and a minus sign (-) indicating lead.
- The polarity sign for fundamental wave power factor (λ_{fnd}) and fundamental wave reactive power (Q_{fnd}), which are calculated using measured harmonic values, indicates the sign of the calculation, which is the opposite of the signs of power factor (λ) and reactive power (Q). (when the power calculation method is set to Type 1)
[See "10.5 Specifications of Equations" \(p.375\)](#)
- The polarity sign for power factor, reactive power, and power phase angle may not stabilize when there is a large difference between the voltage and current levels or when the power phase angle approaches 0°.

- In 3P3W2M or 3V3A wiring mode, active power (P), reactive power (Q), apparent power (S), and power factor (λ) are undefined for all channels. Use only the sum value*¹.

*¹ When using a connection other than 1P2W, measured power value calculated as the sum of measured values of at least two channels
(for example, P123, S234, Q34).

IMPORTANT

Measured values may be displayed for channels without input due to the effects of surrounding noise.
Due to induced voltage, displayed values may become unstable with no input; however, this is not a malfunction.

Displaying measured voltage or current values

Display screen: **MEAS** key > **[VALUE]** > **[BASIC]**



1 Tap **[U]** (voltage) or **[I]** (current).

2 Switch the channel to be displayed using the **◀ CH ▶** keys for channel selection.

Urms	Voltage RMS value
Umn	RMS equivalent of voltage average rectified value
Uac	Voltage AC component (AC)
Udc	Voltage simple average (DC)
Ufnd	Voltage fundamental wave component
Upk+	Voltage waveform peak (+)
Upk-	Voltage waveform peak (-)
Uthd	Total harmonic distortion* ¹
Uunb	Unbalance rate* ²
fu	Voltage frequency

Example: Displaying measured voltage values

- *¹ When DC has been selected as the integration mode, the ripple rate will be displayed instead of the total harmonic distortion.
- *² This is displayed in 3V3A, 3P3W3M, or 3P4W wiring mode.

Voltage range and current range

Set the optimal voltage range and current range according to voltage and current of the object under measurement. To ensure precise measurement, select the smallest range that is larger than the input level for both voltage and current.

Range settings on the Measurement screen

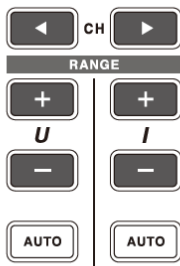

1 Use the ◀ CH ▶ keys for channel selection to light up the channel for which you wish to change the range.

The displayed channel will change each time the ◀ CH ▶ keys are pressed.



2 Set the range with the RANGE key or the AUTO key.

🔍 See “1.3 Part Names and Functions” (p.30)

Auto-ranging and manual ranging

 (Off)	Manual ranging Allows you to set the range as desired. (Repeatedly press the + and - keys under RANGE for both voltage U and current I until the desired range is shown.)
 (Lit up in green)	Auto-ranging Sets the optimal voltage range and current range for each wiring configuration automatically based on the input. (Press the AUTO key for both voltage and current.)

Display of ranges

The voltage and current ranges are displayed in the settings indicator area on the Measurement screen as shown below at all times.

The on-screen ranges and other information are for the channels whose indicators are lit up.

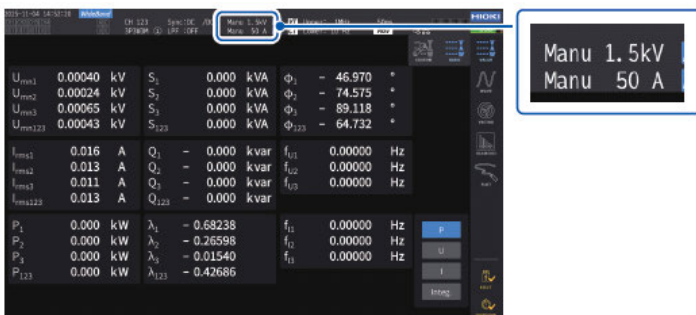

Power range

The power range is used to measure active power P, apparent power S, and reactive power Q.

The power range is determined as follows based on the voltage range, current range, and wiring configuration.

🔍 See “Power range configuration” (p.368)

Example: For active power P (same applies to S and Q)	Power range
P1, P2, P3, P4	(Voltage range) × (Current range)
P12, P23, P34	2 × (Voltage range) × (Current range)
P123, P234 of 3V3A, 3P3W3M	2 × (Voltage range) × (Current range)
P123, P234 of 3P4W	3 × (Voltage range) × (Current range)

Range settings via the **INPUT** key > **[CHANNEL]** screen

You can choose between the manual and auto-ranging. When multiple channels are combined in any mode other than 1P2W mode, all combined channels are forced to use the same range.

Display screen: **INPUT** key > **[CHANNEL]**

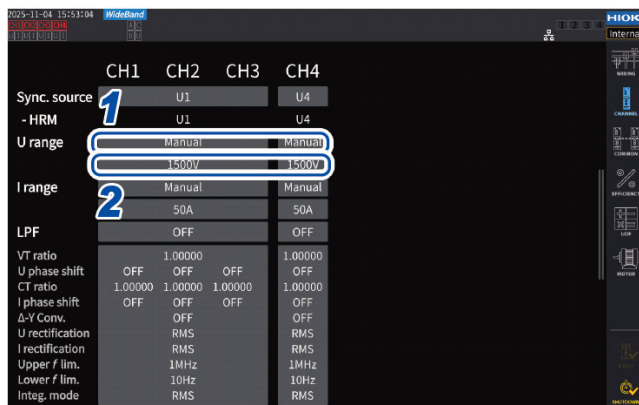

1 Tap the **[U range]** box of the wiring configuration you wish to set and select **[Manual]** or **[Auto]**.

When **[Auto]** is selected, the voltage range will be selected automatically.

2 When **[Manual]** is selected, set the voltage range.

Set the current range in the same way.

Automatic range switching conditions

When Δ -Y conversion is enabled, the range switching is determined by multiplying the range by $1/\sqrt{3}$ (multiplying by approximately 0.57735).

🔍 See “ Δ -Y conversion” (p.175)

Switching range above	<p>When one wiring configuration meets one of the following conditions, the range is switched over to the one immediately above.</p> <ul style="list-style-type: none"> The RMS value is greater than or equal to 110% of the range. The absolute value of the peak value is greater than or equal to 300% of the range.
Switching range below	<p>If all channels in the wiring configuration meet all of the following conditions, the range is switched over to the one immediately below.</p> <ul style="list-style-type: none"> The RMS value is less than or equal to 40% of the range. The absolute value of the peak value is less than or equal to 280% of the range immediately below.

IMPORTANT

Measured values may not be stable immediately after the range is switched.

Tips When the range does not switch immediately

Make sure that the inputs are synchronized and then set the [Lower f lim.] in the [CHANNEL] screen to 1 Hz or higher. Synchronization of the inputs can be confirmed if the synchronization-unlocked indicator is not lit up in yellow.

When the range switches frequently

It is recommended to select a range manually.
 See “Voltage range and current range” (p.86)

Setting the zero suppress

The zero suppress capability allows values less than the value set for the measurement range to be treated as zero.

If you want to measure even a tiny input relative to the range, set it to [OFF].

Display screen: **INPUT** key > [COMMON]

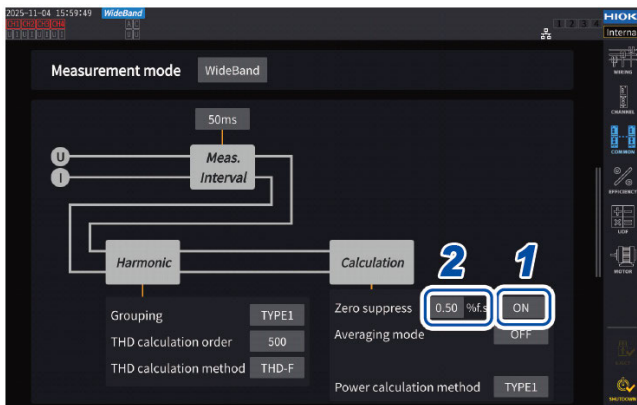

- 1 Tap either the ON or OFF box for [Zero suppress] and select a setting.

Off	Does not enable the zero suppress capability.
ON	Allows values less than the value set for the measurement range to be zero.

- 2 (If zero suppression is ON)
Set the threshold value.

0.01% f.s. to 1.00% f.s.

Data update interval

Measured values are calculated from the voltage and current waveforms, and the period for updating the measured data is set.

Data acquired through communications, analog output data from D/A output, and data saved in interval saving will be updated at the update intervals set here.

Display screen: **INPUT** key > **[COMMON]**

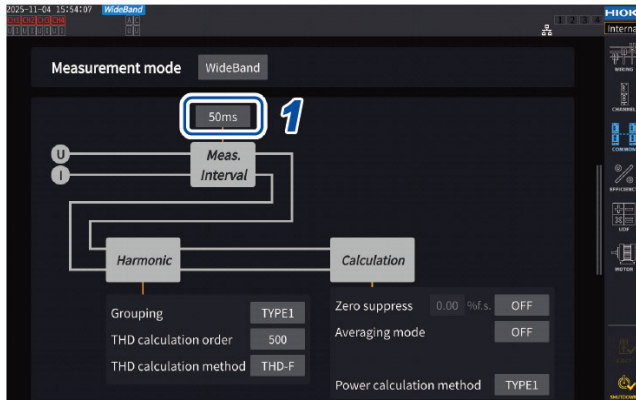

- 1 Tap the **[Meas. Interval]** box and select the data update interval from the list.

Data update interval

1 ms	<p>Select when you wish to acquire slight fluctuations. Even when 1 ms is selected, harmonic analysis operates at 50 ms intervals. The 1 ms interval cannot be used during BNC synchronization. For frequencies lower than 1 kHz, the update interval may be a whole number multiple of 1 ms.</p> <p>This setting cannot be used with each of the following functions:</p> <ul style="list-style-type: none"> • Average mode If the data update interval is set to 1 ms, the average function will be set to OFF. • User-defined formula The instrument will display [-----].
10 ms	<p>Select this interval when measuring fast power fluctuations. Even when 10 ms is selected, harmonic analysis operates at 50 ms intervals. The 10 ms interval cannot be used during BNC synchronization. For frequencies lower than 100 Hz, the update interval may be a whole number multiple of 10 ms.</p>
50 ms	<p>In general, select [50 ms]. This option provides a good balance between speed and accuracy. For frequencies lower than 20 Hz, the update interval may be a whole number multiple of 50 ms.</p>
200 ms	<p>Select this interval when the measured values are unstable at 50 ms due to large fluctuations. Also select when IEC measurement mode is used for harmonics measurement. The data is updated almost simultaneously with the display update interval. For frequencies lower than 5 Hz, the update interval may be a whole number multiple of 200 ms.</p>

- Settings cannot be switched on a wiring configuration or channel basis.
- The display update interval is fixed at approximately 200 ms regardless of this setting.

3.2 Measuring Power

- If the measured values are unstable even when 200 ms is selected, use together with the average function.
- To obtain a D/A output close to the smooth analog output of the previous model, 3193, select 10 ms and combine this setting with the exponential average or moving average of the average function.

Synchronization source

This section describes how to set the source for each wiring configuration, which determines the period (between zero-crossing points) that serves as the basis for various calculations.

In general use, select the measurement channel's voltage for channels measuring AC current or **[DC]** for channels measuring DC current.

Display screen: **INPUT** key > **[CHANNEL]**



- 1 Tap the **[Sync. source]** box of the wiring configuration you wish to set to open the setting window.

The set synchronization source will be displayed by the **[Sync]** setting indicator at the top of the Measurement screen.

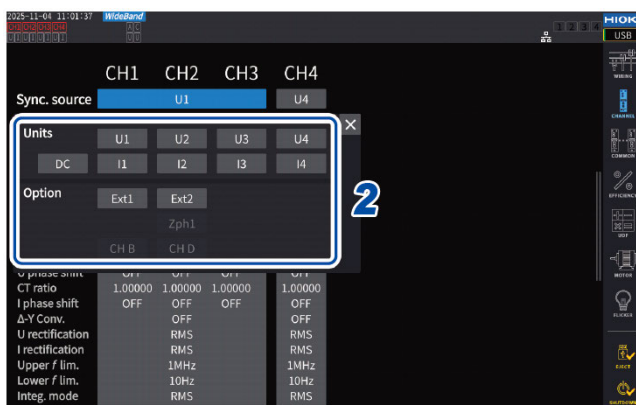

- 2 Tap a synchronization source module to select it.

Synchronization source module

U1 to U4	Set this when performing measurement with respect to a voltage signal.
I1 to I4	Set this when performing measurement with respect to a current signal.
DC	Set this when performing measurement with respect to the data update interval.
Ext1 to Ext2	<p>This may be set when the input settings of the following channels of the motor analysis-equipped model are [Speed] (pulse input) and the remainder of $\{(pulse\ count) / [(Number\ of\ poles) / 2]\}$ is zero.</p> <p>Ext1: Ch. B, Ext2: Ch. D</p> <p>Set this for measurement with respect to pulses in motor analysis or when measuring electrical angles.</p>

Zph1	This can be set when the input settings of the following channels of the motor analysis-equipped model are [Origin] (pulse input). Zph1: Ch. D Set this if you wish to obtain measurement results synchronized to one cycle of the motor's mechanical angle during motor analysis.
Ch. B, Ch. D	This may be set when the operation mode of the relevant channel of the motor analysis-equipped model is [Individual] mode. Set this when you wish to perform measurement synchronized to an external signal (pulse input).

- The same synchronization source will be set for each channel's voltage and current.
- The same synchronization source will be used for each channel's harmonic measurement. Note, however, that if **[Zph1]** is selected as the synchronization source and **[Ext1]** is selectable, either **[Ext1]** or **[Zph1]** is selectable as the synchronization source for harmonic measurement.
- For channels measuring AC current, select an input with the same frequency as the measured signal's frequency as the synchronization source. If the frequency of the signal selected as the synchronization source differs significantly from the measured signal's frequency, the instrument may display a frequency that differs from the input, and measured values may become unstable.
- Segments for which **[DC]** has been selected will be matched with the data update interval. (1 ms, 10 ms, 50 ms, 200 ms) If AC input is measured using the **[DC]** setting, the displayed values may fluctuate, making accurate measurement impossible.
- If a frequency lower than the measurement lower frequency limit setting or higher than the measurement upper frequency limit setting is inputted as the synchronization source while the synchronization source is set to a setting other than **[DC]**, the instrument may display a frequency that differs from the input, and measured values may become unstable.
- Selecting **[Ext]** makes it easier to achieve synchronization when the motor's RPM varies over short periods of time, making it useful in power analysis.
[🔍 See "Measuring the electric angle of the motor" \(p.139\)](#)
- When you select **[Zph.]**, you can perform harmonic analysis based on one motor revolution (one cycle of the mechanical angle).
- The zero-crossing interval cannot be acquired when the synchronization source for a channel to which DC is being input is set to voltage or current. The instrument will operate with a synchronization frequency equivalent to approximately one period of the measurement lower frequency limit.
- Frequencies lying close to the measurement lower frequency limit setting may cause channels to enter a synchronization-unlocked condition, resulting in unstable measured values.
- By inputting a pulse signal to Ch. B and Ch. D of the instrument with the motor analysis and selecting Ch. B and Ch. D, respectively, as the synchronization source, you can set the measurement timing as desired. Note that the rising edge of the input pulse is detected for Ch. B and Ch. D.
- If settings are changed, synching to the synchronization source may become unstable for a certain period of time depending on the item that was changed.

Synchronization-unlocked condition

Channels that cannot be synchronized to the synchronization source will fall into a synchronization-unlocked condition, preventing accurate measurement.

Check synchronization source input.

A warning indicator will come on to indicate a synchronization-unlocked condition occurs.

[🔍 See "Common screen display" \(p.41\)](#)

Low-pass filter (LPF)

The instrument provides a low-pass filter function to limit the frequency band.

This filter can eliminate frequency components and unnecessary external noise components that exceed the set frequency. Normally, you should disable the low-pass filter during measurement.

Display screen: **INPUT** key > **[CHANNEL]**

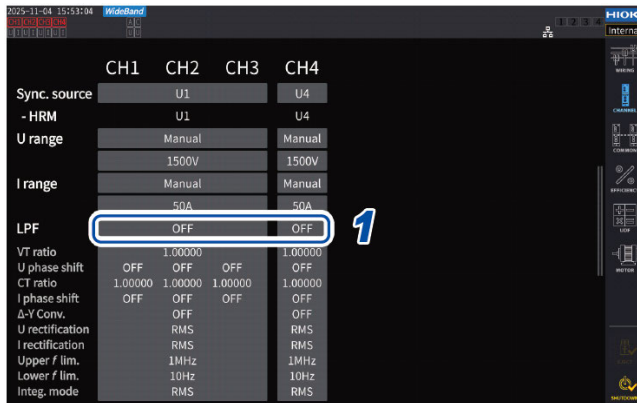

1 Tap the **[LPF]** box of the wiring configuration you wish to set and select a low-pass filter from the list.

This can be set for each wiring configuration. Swipe the touchscreen to scroll the list and then select the cutoff frequency for other wiring configurations.

500 Hz, 1 kHz, 5 kHz, 10 kHz, 50 kHz, 100 kHz, OFF

The set low-pass filter will be displayed by the **[LPF]** setting indicator at the top of the Measurement screen.

🔍 See “Measurement screen” (p.43)

Measurement upper frequency limit and lower frequency limit (configuring frequency measuring range)

The instrument can simultaneously measure multiple circuits' frequency values. Frequency measurement includes a measurement lower frequency limit setting and a measurement upper frequency limit setting so that you can limit the range of frequencies you wish to measure for each wiring configuration. When measuring waveforms with multiple frequency components such as a PWM waveform's fundamental frequency and carrier frequency, configure the settings based on the input frequencies you wish to measure.

Display screen: **INPUT** key > **[CHANNEL]**

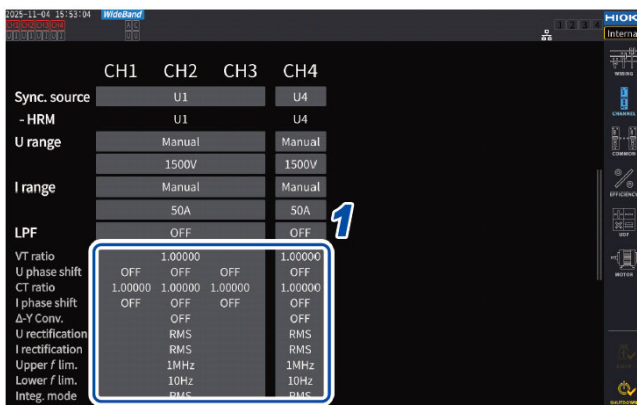

- 1 To open the settings window, tap the channel detailed display area.
Detailed settings for each wiring configuration can be seen in this window.

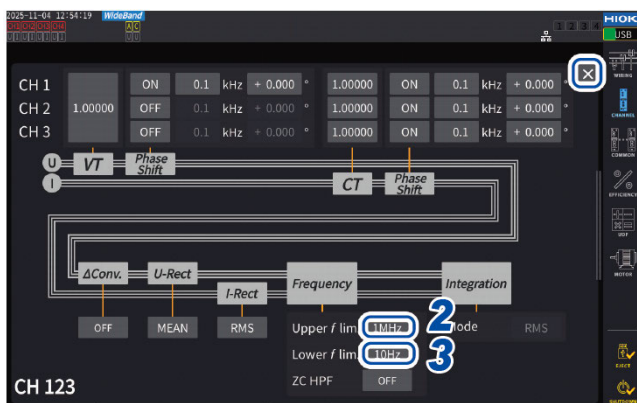

- 2 Tap the **[Upper f lim.]** box and then select the upper frequency limit from the list.

100 Hz, 500 Hz, 1 kHz, 5 kHz, 10 kHz, 50 kHz, 100 kHz, 500 kHz, 1 MHz

- 3 Tap the **[Lower f lim.]** box and then select the lower frequency limit from the list.

0.1 Hz, 1 Hz, 10 Hz, 100 Hz, 1 kHz, 10 kHz, 100 kHz

IMPORTANT

Accuracy for frequency measurement is guaranteed for sine wave input greater than or equal to 30% of the voltage or current range. The instrument may not be able to measure input outside that range.

- When receiving input at a frequency lower than the data update interval setting's period, the data update interval will vary with the input frequency.
- The instrument may display a frequency that differs from the input if a frequency significantly higher than the measurement upper frequency limit or a frequency lower than the measurement lower frequency limit is inputted.

Zero-cross high-pass filter (ZC HPF)

- This high-pass filter setting is used to detect waveform zero-crossing points.
- If the frequency does not stabilize during measurement of low frequencies, setting **[ZC HPF]** to OFF can stabilize the frequency.
- Set **[ZC HPF]** to ON while measuring ripple current.

Rectification method

This section describes how to select the rectification method for voltage values and current values used to calculate apparent power, reactive power, and power factor.

You can select a rectification method for each wiring configuration's voltage and current independently.

Display screen: **INPUT** key > **[CHANNEL]**



- 1 To open the settings window, tap the channel detailed display area.

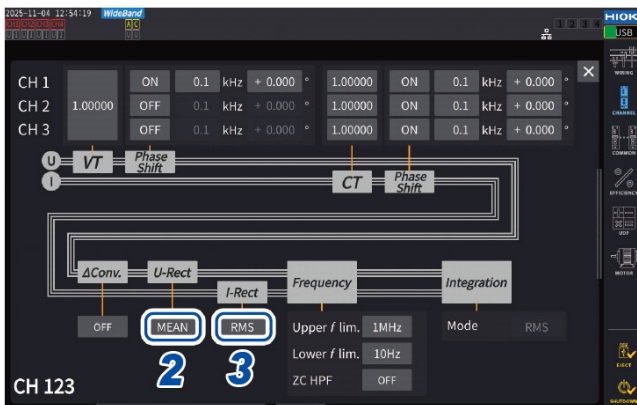

- 2 Tap the **[U-Rect]** box and then select the rectifier from the list.

RMS	(True RMS value) Select this setting for ordinary use.
MEAN	(RMS equivalent of average rectified value) In general, this setting is only used when line voltage with a PWM waveform on the secondary side of an inverter is measured.

- 3 Tap the **[I-Rect]** box and then select the rectifier from the list.

Scaling (when using VTs [PTs] or CTs)

This section describes how to set the ratio (VT ratio, CT ratio) when using VTs (PTs) or CTs externally. When a VT ratio or CT ratio has been set, **VT** or **CT** will be displayed with the setting indicators at the top of the Measurement screen.

Display screen: **INPUT** key > **[CHANNEL]**



- 1 To open the settings window, tap the channel detailed display area.

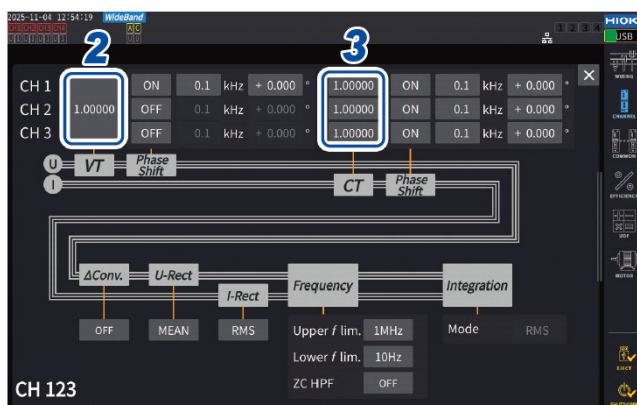

- 2 Tap the **[VT]** box and then set the VT ratio using the numeric keypad.

See “Numeric keypad window” (p.39)
Set the VT ratio to a common value for channels in the same wiring configuration.

0.00001 to 9999.99

- 3 Tap the **[CT]** box and set the CT ratio using the numeric keypad.

The CT ratio can be set individually for each channel in the same wiring configuration.

0.00001 to 9999.99

The settings cannot be configured such that the product of VT and CT is greater than 1.0E+06. When a VT ratio has been set, all voltage measurement parameters, including voltage peak values, harmonics, and waveforms, and all measured values for power measurement parameters calculated using voltage will be multiplied by the set ratio. When a CT ratio has been set, all current measurement parameters, including current peak values, harmonics, and waveforms, and all measured values for power measurement parameters calculated using current will be multiplied by the set ratio. To set it to OFF, enter 1.00000.

3.3 Integration Measurement

Integration control setting

There are two types of integration measurement available: integration for all wiring configurations, which controls all installed channels at once, and integration by wiring configuration, which controls each set wiring configuration.

When you wish to control the integration independently for each set wiring configuration, use the function of integration by wiring configuration.

By selecting buttons displayed on the screen, you can change the wiring configuration to be controlled, and set the integration start time, stop time, and timer setting value for each wiring configuration to control the time.

Display screen: **SYSTEM** key > **[TIME CONTROL]**

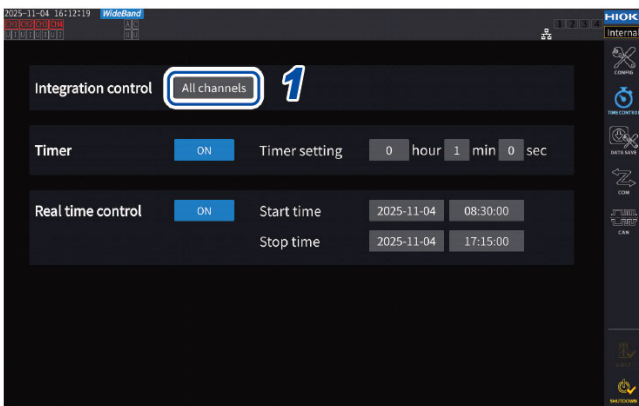

- 1 Tap the **[Integration control]** box to select an integration control setting from the list.

All Channels	(All wiring-configuration integration) Controls integration with the same timing for all wiring configurations.
Each Wiring	(Each wiring-configuration integration) Controls integration with an independent timing for each set wiring configuration.

Displaying integrated measured values

The instrument can simultaneously integrate the current (I) and active power (P), and displays positive, negative, and total values.

Displaying integration information

Display screen: **MEAS** key > **[VALUE]** > **[BASIC]**

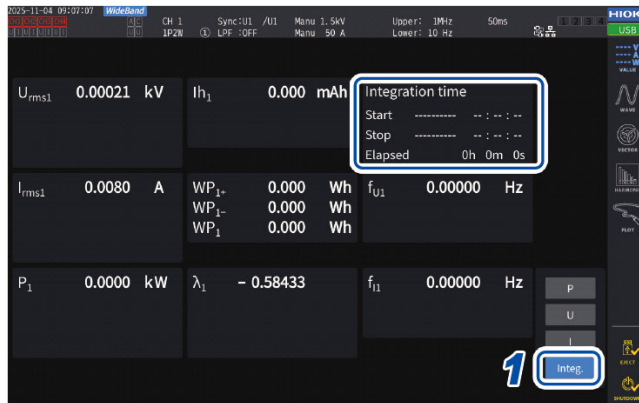

1 Tap **[Integ.]**.

2 Switch the channel to be displayed using the **◀ CH ▶** keys for channel selection.

The displayed channel will change each time the **◀ CH ▶** keys are pressed.

When the integration control is set to [All Channel], the **[Integration Time]** field displays the integration start time, integration stop time, and elapsed time common to all wiring configurations.

When the integration control is set to [Each Wiring], it displays the integration start time, integration stop time, and elapsed time of the wiring configuration selected using the **◀ CH ▶** keys.

lh₁₊	Integrated positive current value of Ch. 1 (displayed only when the integration mode is DC)
lh₁₋	Integrated negative current value of Ch. 1 (displayed only when the integration mode is DC)
lh₁	Sum of integrated current values of Ch. 1
WP₁₊	Integrated positive active power value of Ch. 1
WP₁₋	Integrated negative active power value of Ch. 1
WP₁	Sum of integrated active power values of Ch. 1

- The parameters that can be integrated vary with the wiring mode and the integration mode.
[Q See](#) “2.5 Setting Wiring Mode and Configuring Current Sensor Settings” (p.66), “Integration mode” (p.102)
- This information can also be selected and displayed on the **CUSTOM** screen.
[Q See](#) “3.1 Displaying Measured Values” (p.81)

Before starting integration

- Adjust the clock.
[Q See](#) “6.1 Checking and Changing Settings” (p.189)
- Set the integration mode.
[Q See](#) “Integration mode” (p.102)
- Set the necessary control times.

3.3 Integration Measurement

🔍 See “Integration measurement while using the time control function” (p.104)
Set the time settings to OFF when performing integration manually or with an external signal.

4 When saving to a USB flash drive or the internal memory, configure the items to be saved.

🔍 See “7.2 USB flash drive” (p.201)
🔍 See “7.5 Saving Measured Data” (p.206)

5 When generating D/A output, configure the D/A output settings.

🔍 See “8.2 Waveform/Analog Output (Waveform and D/A Output Option)” (p.242)

How to start/stop integration and resetting integrated values

These operations can be performed using the instrument’s control keys, external signals, or communications.

Always reset integrated values when changing settings.

When the integration control is set to **[All Channel]**

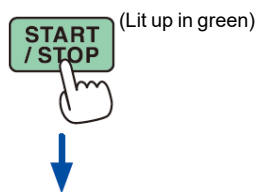

- 1** Press the **START/STOP** key.
Integration starts.
The key lights up in green.
The integration state indicator will turn green.

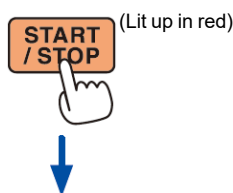

- 2** Press the **START/STOP** key.
Integration stops.
The key lights up in red.
The integration state indicator turns red.



- 3** Press the **DATA RESET** key to reset integrated values.
The **START/STOP** key light is turned off.
The integration state indicator will be colorless.

When the timer control or real time control setting is used, integration will stop automatically at the set end time.

This section describes how to start and stop integration manually.

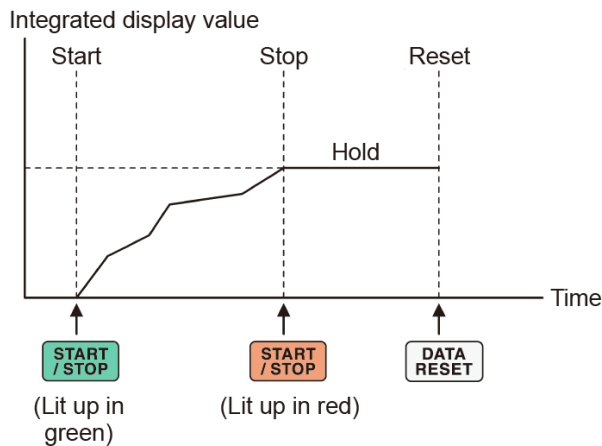
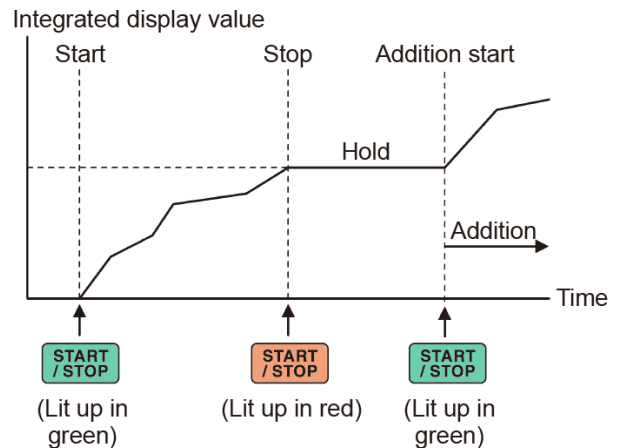
Manual integration operation**Cumulative integration operation****When the integration control is set to [Each Wiring]**

Select the channels to be operated by the **START/STOP** key or the **DATA RESET** key in either of the following screens to control.

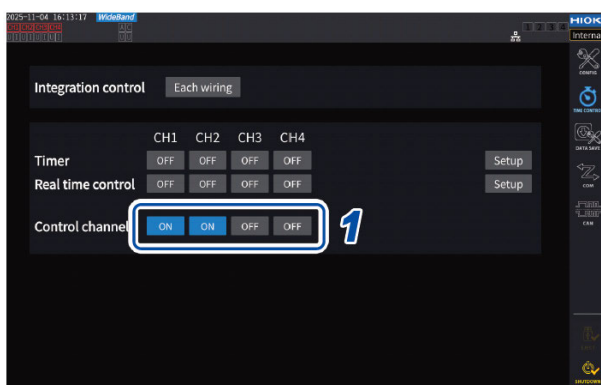
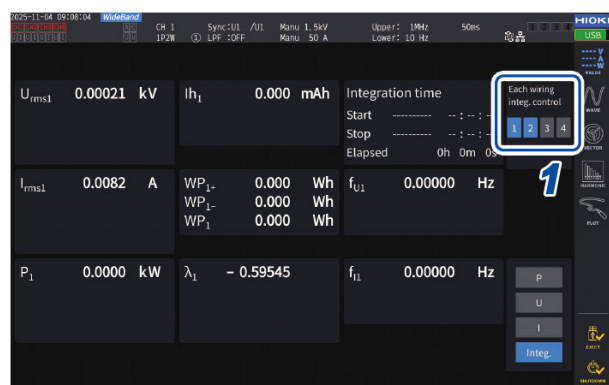
Display screen: SYSTEM key > [TIME CONTROL]**Display screen: MEAS key > [VALUE]**

- 1** Select a button on the **[TIME CONTROL]** screen or a channel number button in the upper right corner via the **MEAS** key > **[VALUE]** screen.
- 2** Press the **START/STOP** key.
The instrument starts integrating values of channels whose integration has been reset or stopped among the channels selected in step 1. The key does not light up, but the integration state indicator in the upper right corner of the screen turns green.
- 3** Press the **START/STOP** key.
The instrument stops integrating values of channels whose integration is in progress among the channels selected in step 1. The key does not light up, but the integration state indicator in the upper right corner of the screen turns red.
- 4** Press the **DATA RESET** key as necessary.
The instrument resets integrated values of the channels selected in step 1. When using the timer control or real time control settings, integration will stop at the set end time.

Precautions when starting and stopping integration and resetting integrated values

- Integration will stop automatically when the integration time reaches 9999 h 59 min. 59 s.
- Starting and stopping of integration and resetting of integrated values performed using the instrument's control keys or external control affect all parameters being integrated in synchronization.
- The following parameters can be integrated depending on the wiring mode and integration mode:

Mode	Parameters that can be integrated
1P2W, DC mode	Ih+, Ih-, Ih, WP+, WP-, WP
1P2W	Ih, WP+, WP-, WP
1P3W, 3P3W2M (When using Ch. 1, Ch. 2)	Ih1, Ih2, WP12+, WP12-, WP12
3V3A, 3P3W3M, 3P4W (When using Ch. 1, Ch. 2, Ch. 3)	Ih1, Ih2, Ih3, WP123+, WP123-, WP123

- Calculation results from each channel are integrated at the data update intervals. Consequently, integrated values may differ from those of an instrument whose response speed, sampling speed, or calculation methods differ.
- In current integration, the instantaneous current values are integrated when the integration mode is DC mode, and RMS values are integrated when the integration mode is RMS mode.
- In power integration, the instantaneous power values are integrated when the integration mode is DC mode, and active power values are integrated when the integration mode is RMS mode.
- While integration is being performed (including when the instrument is in standby mode during real time control integration), the instrument will not accept any settings changes other than screen changes, hold/peak hold function operation, and range changes.
- Even when the display is held during hold operation, integration operation continues internally. However, displayed data are output as the D/A output.
- The integration display is not affected by peak hold operation.
- If a power outage occurs during integration, integrated values will be reset, and integration operation will stop.

IMPORTANT

No data is integrated while the ranges are being switched manually or automatically.

Integration mode

This section describes how to set the integration mode for each channel. The two integration modes, DC and RMS, are available and can be selected separately for each wiring configuration.

Display screen: **INPUT** key > **[CHANNEL]**



1 To open the settings window, tap the channel detailed display area.

Detailed settings for each wiring configuration will be displayed.

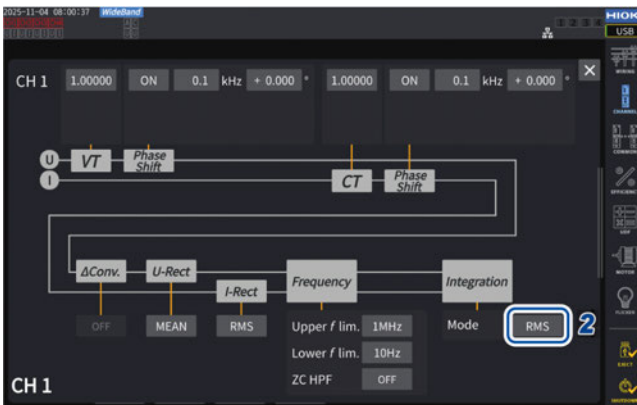

2 Tap the **[Mode]** box and then select the integration mode from the list.

DC	<p>Instantaneous current values and instantaneous power values for each sampling are integrated separately for each polarity.</p> <p>This can be selected only in 1P2W wiring mode. The six items of current integration (Ih+, Ih-, Ih) and active power integration (WP+, WP-, WP) are calculated simultaneously.</p>
RMS	<p>Current RMS value and active power value acquired at data update intervals are integrated.</p> <p>Only active power values are integrated by polarity.</p>

Integration measurement while using the time control function

If you set the timer setting value and real time control time in advance and then press the **START/STOP** key, you can start or stop the integration at the set times. When the integration control is set to All Channel, the timer setting value and real time control time, which apply commonly to all wiring configurations, can be set.

If the integration control is set to Each Wiring, timer setting value and real time control time can be set for each set wiring, and pressing the **START/STOP** key can start or stop integration at the set times for selected channels.

Manual integration setting

Integration start	Press the START/STOP key.
Integration stop	Press the START/STOP key again.

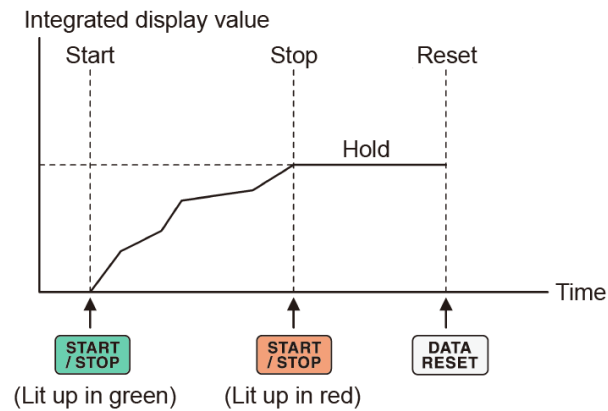

Timer integration setting

Integration start	Press the START/STOP key.
Integration stop	Press the START/STOP key again.

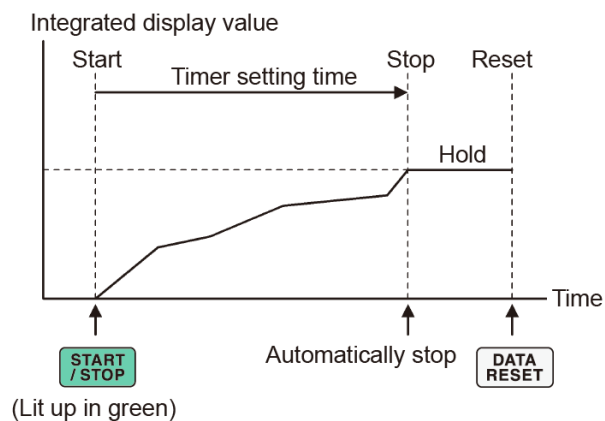

Real time control integration setting

Start integration, stop integration	Press the START/STOP key places the instrument in the standby state. Integration will then start and stop at the set start time and stop time. To stop integration while the instrument is in the standby state, press the START/STOP key again.
--	--

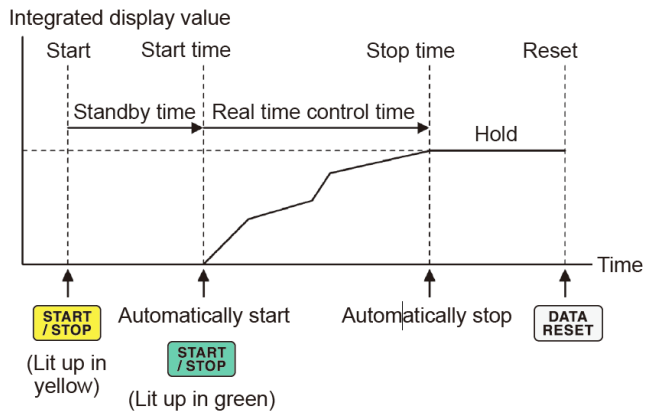

3.4 Measuring Harmonics

The instrument includes harmonic measurement functions as a standard feature and can acquire measured harmonic values synchronous with measured power values for all channels. These measured harmonic values are used to calculate the fundamental wave component (fnd value) and total harmonic distortion (THD), which are included in the instrument's basic measurement parameters.

🔍 See “10.5 Specifications of Equations” (p.375)

In addition, setting the wideband measurement mode and IEC measurement mode allows the instrument to perform harmonic measurements that support wideband and harmonic measurements that conform to IEC standards.

IEC measurement mode is enabled when the PW9006 IEC harmonic/flicker measurement function (optional) is installed.

🔍 See “2.7 Measurement mode” (p.72)

Wideband measurement mode

- It can be measured with a wide frequency range from 0.1 Hz to 600 kHz.
- The analysis order differs depending on the frequency to be measured.
- Only harmonic measured values are updated at intervals of 50 ms.

IEC measurement mode (PW9006 option)

- The instrument in this mode can measure IEC harmonics and IEC voltage fluctuation/flicker.
- When the measurement line has a frequency of 50 Hz or 60 Hz, the instrument can perform harmonic measurements according to IEC61000-4-7 and voltage fluctuation/flicker measurements according to IEC61000-4-15.
- The data update interval is fixed at 200 ms.
- Accurately measured values for harmonic measurement and voltage fluctuation/flicker measurement cannot be guaranteed if the frequency to be measured falls outside the range of 45 Hz to 66 Hz.
- The harmonic analysis can be performed for the 0th to 200th orders; and the intermediate harmonic analysis, from the 0.5th to 200.5th orders.

In IEC measurement mode, internal calculation processing differs from the wideband measurement mode to realize measurements in compliance with the IEC standard. Thus, some functions are restricted in IEC measurement mode.

🔍 See “2.7 Measurement mode” (p.72)

Displaying measured harmonic values

Harmonics can be displayed using a bar graph, list, or vectors.

Displaying a harmonics bar graph

Harmonic analysis is performed on the voltage, current, and active power values for the same channel, and the results are displayed as bar graphs.

Numerical data of the on-screen order is also displayed at the same time.

Display screen: **MEAS** key > **[HARMONIC]** > **[BAR GRAPH]**



- 1 Tap the **[Item]** box and then select channels to be displayed on the bar graph.
- 2 Tap the **[Scale]** box and then select a scale of the vertical axis from the list.

Log	Logarithmic scale
Linear	Linear scale This can display data down to minuscule levels. When [Phase] is selected, the vertical axis display is fixed to [Linear] .

1	Harmonic voltage
2	Harmonic current
3	Harmonic active power



On-screen measured values of the selected orders

W	Amplitude value (Level)
%	Content percentage (% of Fnd)
°	Phase angle (phase)

- The value scale is a percentage of the range when the amplitude value is selected.
- When the phase angle is selected, dimmed bars may be displayed to indicate that the corresponding amplitude value is small (0.01% or less of the range).

Changing the display settings and an order to be displayed



<p>1</p>	<p>To change the display settings Tap each setting and change it as desired.</p>
<p>2</p>	<p>To change an order to be displayed Tap the [Order] box to select the order using the Y rotary knob. Tapping the [Order] box again turns the rotary knob light off.</p> <p>Y rotary knobs</p> <div style="display: flex; align-items: center;">  <div style="margin-left: 10px;"> <p>Lit up in green: in 1 increments</p> </div> </div> <div style="display: flex; align-items: center; margin-top: 10px;">  <div style="margin-left: 10px;"> <p>Lit up in red: in 10 increments</p> </div> </div> <p style="margin-left: 40px;">Press the knob to switch.</p>
<p>3</p>	<p>A bar of the selected order will turn green.</p>
<p>4</p>	<p>Measured values of the selected order is displayed. Tapping ▲ on the screen hides the measured values.</p>

Displaying an inter-harmonic bar graph

The instrument in IEC measurement mode can display inter-harmonic.

Setting **[Interharmonics]** to **[ON]** allows the instrument to display a bar graph showing inter-harmonic components as cyan bars representing a combination of current and voltage RMS values and their content ratios. The numerical value area shows the measured values of the inter-harmonic adjacent to the selected order (**[Order]**).



- 1 Tap the **[Interharmonics]** box to set it to **[ON]**.

The bar graph is displayed.

For power measurement, which does not include inter-harmonic measurement parameters, only harmonics components are displayed.

In addition, setting **[Content]** to **[Phase]** sets **[Interharmonics]** to **[OFF]**.

Displaying a harmonics list

This section describes how to display the results of harmonic analysis as a numerical list for each parameter. The same settings affect the bar graph screen and the list screen. Swiping the list horizontally or tapping the **[<]** and **[>]** symbols on either side of the list can change the orders to be displayed.

Display screen: **MEAS** key > **[HARMONIC]** > **[LIST]**

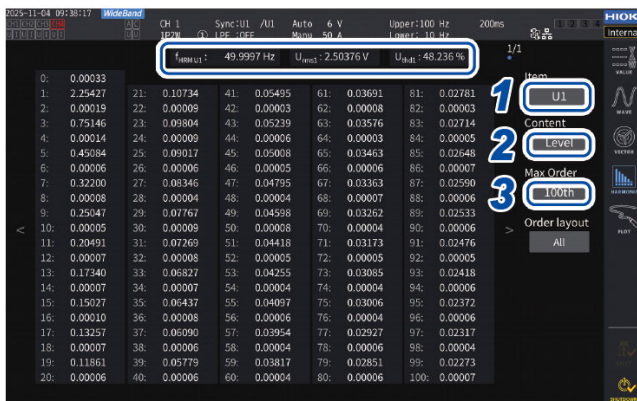

- 1 Tap the **[Item]** box and then select channel to be displayed in a list.

- 2 Tap the **[Content]** box and then select the contents to be displayed from the list.

Level	Amplitude value
% of Fnd	Content percentage
Phase	Phase angle

The phase angle for harmonic active power refers to the harmonic voltage-vs.-current phase difference.

- 3 Tap the **[Max Order]** box and select the highest order to be displayed from the list.

50th, 100th, 200th, 500th

The instrument may not be able to display data up to the set highest order depending on the synchronization frequency being measured.

f_{HRM U1}	Synchronization source frequency
U_{rms1}	RMS value of displayed item
U_{thd1}	Total harmonic distortion

3.4 Measuring Harmonics

Displaying an inter-harmonic list

The instrument in IEC measurement mode can display inter-harmonic.

Setting the **[Interharmonics]** setting to **[ON]** allows the inter-harmonic components to display next to the harmonic readings.

The measured values of harmonics are displayed on the left and those of inter-harmonic are displayed on the right.



1 Tap the **[Interharmonics]** box to set it to **[ON]**.

The inter-harmonic list can be displayed for RMS values and harmonic factors of voltage and current.

If any other option is selected, **[Interharmonics]** will be set to **[OFF]**.

Changing the layout of the harmonic list display

You can change the list-layout by setting **[Order layout]**.

All

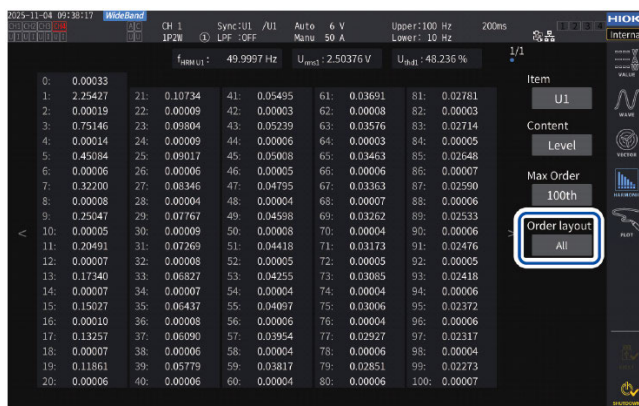

Select to display all orders side by side in one column. One type of measured values are displayed from the 0th to 50th or 100th orders on a single screen.

Odd/Even

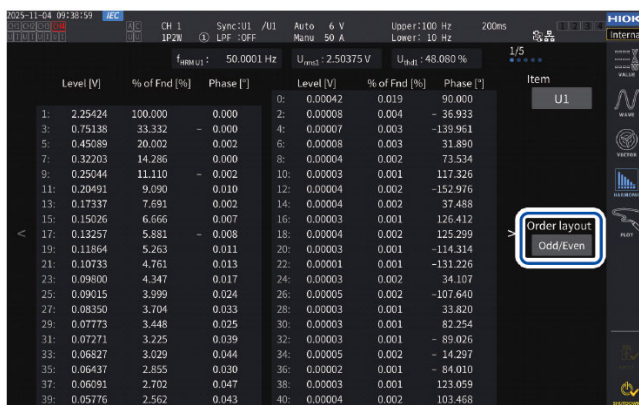

Select to display a list with odd-order measured values arranged on the left side of the screen and even-order measured values on the right side. Three types of measured values (RMS values, harmonic factors, and phase angles) of voltage, current, and power are displayed from the 0th to 40th orders on a single screen.

Displaying harmonic vectors

This section describes how to display the voltage, current, and phase angle for each harmonic order as a vector graph.

1-vector-diagram display

Displays vectors for all channels on a single vector graph.

Display screen: **MEAS** key > **[VECTOR]** > **[VECTOR1]**



- 1 Tap a channel button to be displayed.
- 2 Tap the **[Order]** box, rotate the Y rotary knob to set the display order, and then tap the **[Order]** box to confirm.
Lit up in green: in 1 increments
Lit up in red: in 10 increments
- 3 Tap the **[Scale]** box, rotate the Y rotary knob to set the magnification, and then tap the **[Scale]** box to confirm.

2-vector-diagram display

Display screen: **MEAS** key > **[VECTOR]** > **[VECTOR2]**



The 2-vector-diagram display illustrates two graphs of each selected wiring configuration.

3.4 Measuring Harmonics

4-vector-diagram display

Display screen: **MEAS** key > **[VECTOR]** > **[VECTOR4]**



The 4-vector-diagram display illustrates four graphs of each selected wiring configuration.

Configuring settings common to harmonics

Display screen: **INPUT** key > **[COMMON]**

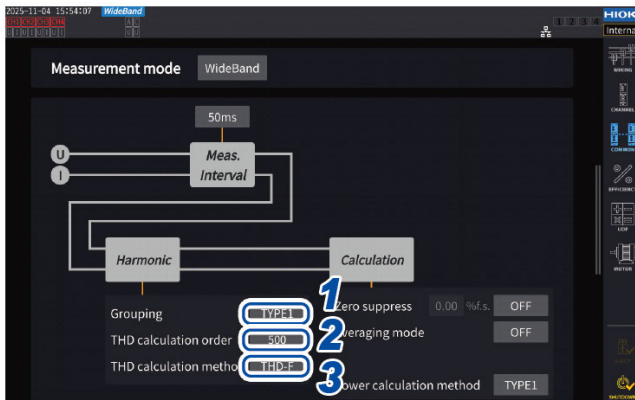

- 1 Tap the **[Grouping]** box and then from the list, select a calculation method of the intermediate harmonic for the measured harmonic values.

Off	Treats only components of a whole number multiple of the fundamental wave as the harmonic of the corresponding order.
Type 1	Treats the harmonic sub-group as the harmonic of the corresponding order. This setting provides compatibility with the Hioki PQ3198's harmonic measurement functions.
Type 2	Treats the harmonic group as the harmonic of the corresponding order.

- 2 Tap the **[THD calculation order]** box, rotate the Y rotary knob to set the THD calculation order, and then tap the **[THD calculation order]** box to confirm.

Lit up in green: in 1 increments

Lit up in red: in 10 increments

THD calculation order: Upper limit order, which means the highest order to which the total harmonics are calculated.

2 to 500 (per step)

- If the analysis order does not reach the set upper limit value due to the measurement mode and fundamental frequency, the calculation will be performed using the analysis order as the upper limit.
- Measured harmonic values displayed in list and graph forms and measured harmonic values obtained via the instrument's communications functionality are not constrained by the upper limit order set here.

- 3 Tap the **[THD calculation method]** box and then from the list select the equation for total harmonic distortion THD.

This setting is valid for all voltage and current harmonic measurement for all channels.

THD-F	Ratio of the total harmonic component to the fundamental wave This setting is typically used in applications such as IEC standard-compliant measurement.
THD-R	Ratio of the total harmonic component to the total harmonic component including the fundamental wave This setting yields values lower than those of THD-F for waveforms with a large amount of distortion.

What is THD?

THD, which stands for total harmonic distortion factor, is a ratio of the RMS value of the harmonic content to the RMS value of the fundamental component or the reference fundamental component of an alternating quantity.

What is grouping?

The harmonic measurement determines the number of the window waves depending on the measurement mode and the fundamental wave frequency. When the number of window waves is other than one, spectrum lines (output bin), the number of which is proportional to the number of the window waves ($[\text{number of window waves}] - 1$), can be acquired between the harmonic components having a frequency of a whole number multiple of (n times) the fundamental wave. They are known as the intermediate harmonic (inter-order harmonic).

Since measured values yielded by harmonic measurement differ depending on how these intermediate harmonics are treated, IEC and other standards define grouping rules.

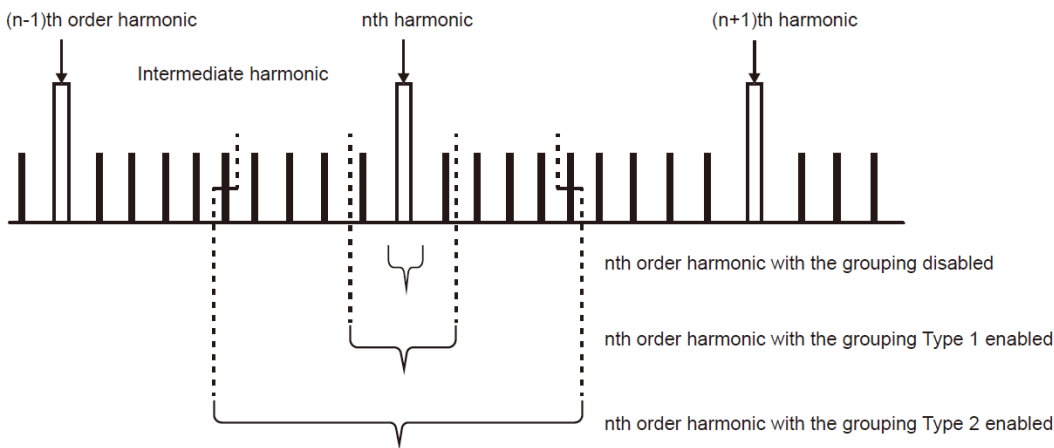

In general, the Type 1 range is known as the harmonic sub-group, and the Type 2 range is known as the harmonic group, which are calculated by determining the square-root of sum of squares the output bins. If no intermediate harmonic exists, or the number of the window waves is one in wideband measurement mode, measured values will agree regardless of what grouping method has been chosen. If intermediate harmonics exist, measured harmonic values will generally exhibit the relationship of $OFF < \text{Type 1} < \text{Type 2}$.

Note that inter-harmonic subgroup and inter-harmonic group in IEC measurement mode are as shown in the following diagram.

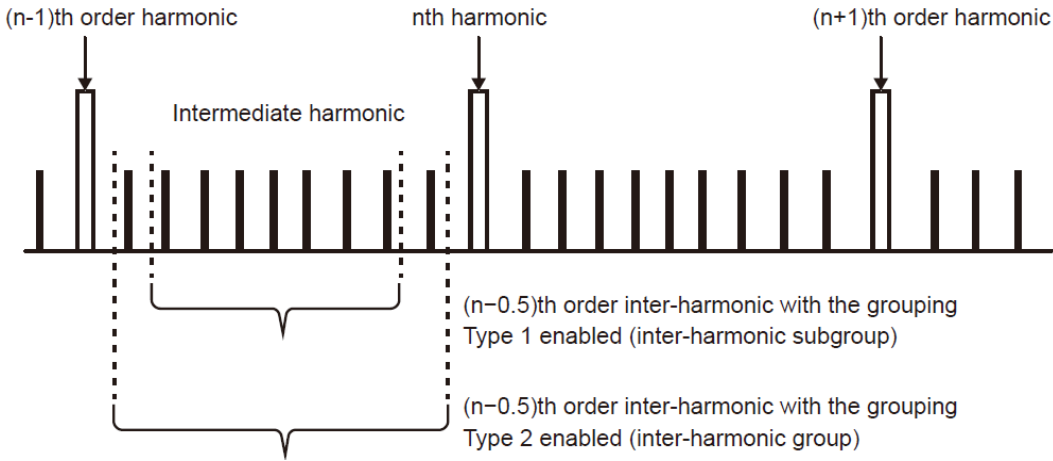

In addition, note that measured inter-harmonic values become zero with the grouping disabled.

3.5 Measuring efficiency and loss

The instrument can calculate the efficiency η (%) and loss (W) using active power values, motor power values, and UDF values, and display them. For example, the instrument can calculate efficiency and loss between input and output of various power converters (e.g., inverters, power conditioners) as well as motors, and simultaneously calculate the overall efficiency.

Selecting the calculation method

Select the efficiency/loss measurement calculation method.

Display screen: **INPUT** key > **[EFFICIENCY]**

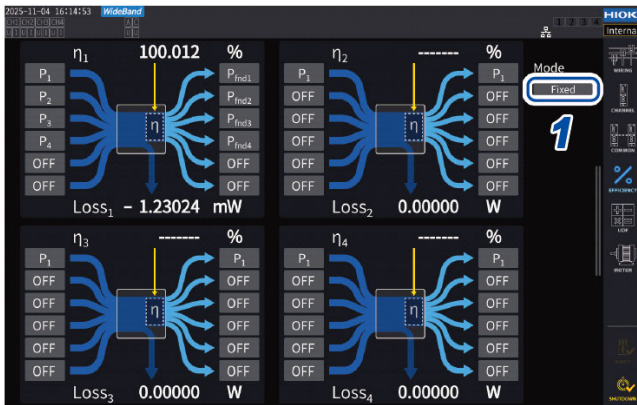

1 Tap the **[Mode]** box to select the calculation mode.

Fixed	Fixed mode
Auto	Automatic mode

[Fixed] mode

This mode can calculate efficiency and loss for set input and output parameters, displaying computational results. You can set four or fewer equations (η_1 to η_4 and **Loss1** to **Loss4**) for each of efficiency (η) and loss (Loss).

Display screen: **INPUT** key > **[EFFICIENCY]**

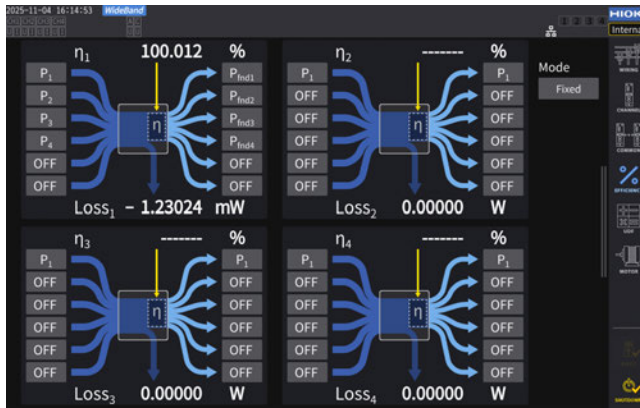

- 1 Select the parameters of the input side of the equation.
 - 2 Select the parameters of the output side of the equation.
- Select the input-side measured power value on the left and the output-side measured power value on the right for each figure on the screen. Up to six inputs and outputs can be selected for each efficiency calculation equation. Efficiency is calculated using the sum of the six.

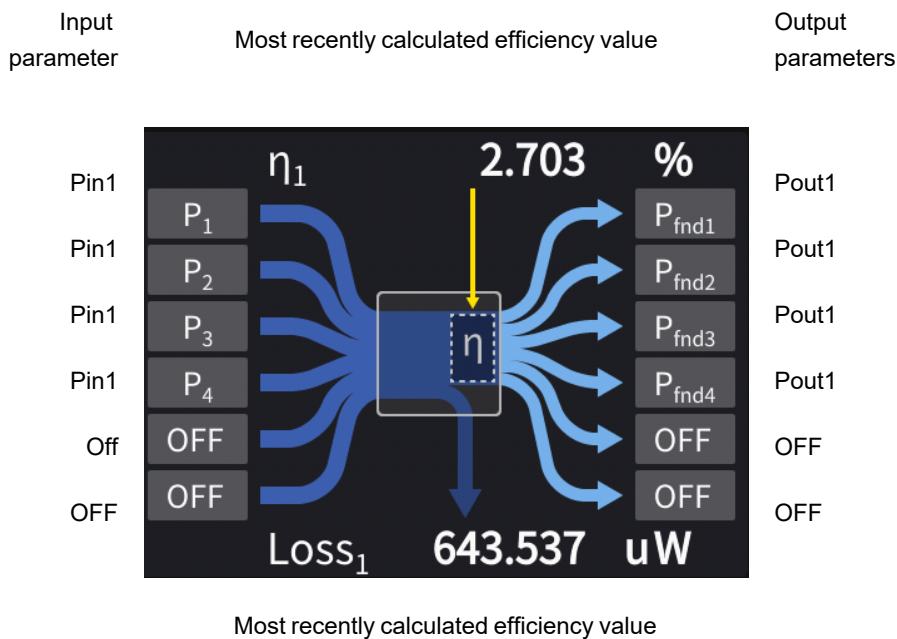

Input side	Pin = Pin1 + Pin2 + Pin3 + Pin4
Output side	Pout = Pout1 + Pout2 + Pout3 + Pout 4
η	$100 \times Pout / Pin $
Loss	$ Pin - Pout $

- Motor power (Pm) measurement is selectable only for the motor analysis-equipped model. Configure settings using the motor input settings screen to measure the motor power (Pm).
[🔍 See “Configuring the motor input settings” \(p.132\)](#)

3.5 Measuring efficiency and loss

- Calculations across wiring configurations with different power ranges are performed using data for the larger of the two power ranges.
- Calculations across wiring configurations with different synchronization sources are performed using the most recent data at the time of calculation.
- Circular references (e.g., configuring Loss1 as a selected parameter for UDF1 or UDF1 as a Loss1 input item) cannot be processed.



To moderate measured value fluctuation

- Measured values may exhibit variations when loads fluctuates severely or transiently. In this case, reduce the data update interval (to 200 ms) and also use the average function's moving average mode.
- When either the input or output is DC, variation in measured efficiency values can be limited by using the same synchronization source setting for the channel used for DC measurement as for the AC side.

[Auto] mode

This mode automatically determines whether measurement targets that change over time are input and output, enabling calculating efficiency and loss.

Configure settings as follows.

	When the value is positive	When the value is negative
Left side of the efficiency chart shown on the screen	Items treated as inputs	Items treated as outputs
Right side of the efficiency chart shown on the screen	Items treated as outputs	Items treated as inputs

Setting example

Measurement of PCU in hybrid cars

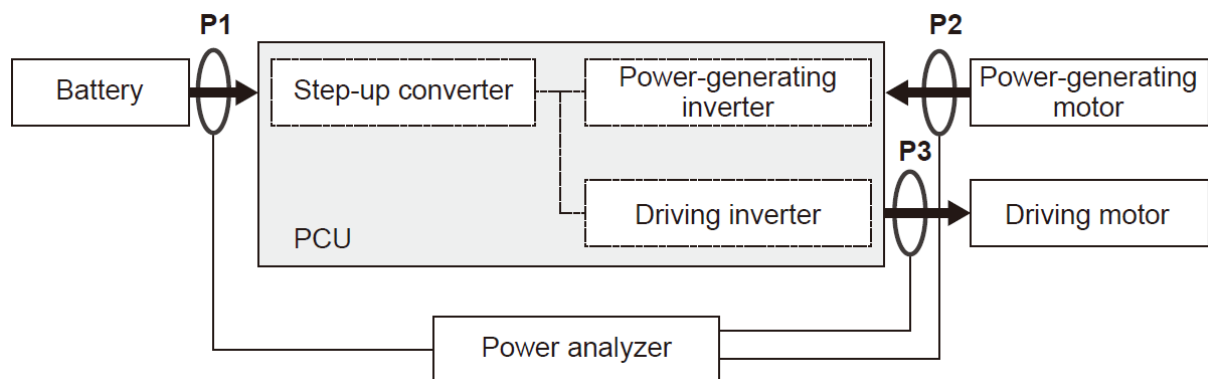

Measure between the PCU and the battery (P1), between the power-generating motors (P2), and between the driving motors (P3) with the instrument.

The inputs and outputs of P1, P2, and P3 change over time depending on the running state of the hybrid vehicle.

During sudden acceleration	P1: input	P2: input	P3: output
During deceleration and braking	P1: output	P2: input	P3: input
During normal operation	P1: output	P2: input	P3: output

The screen and equations of efficiency and loss under the respective driving conditions are as follows: The directions of the arrows change according to the state of input and output of P1, P2, and P3.

3.5 Measuring efficiency and loss

During sudden acceleration

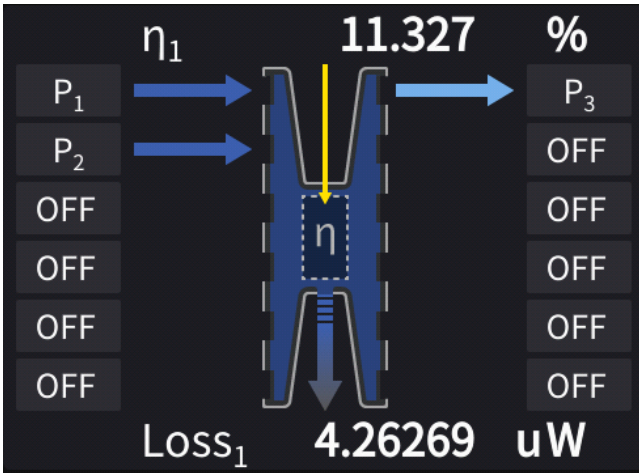

Efficiency: $\eta = \frac{|P_3|}{|P_1| + |P_2|} * 100$

Loss: $Loss = |P_1| + |P_2| - |P_3|$

During deceleration and braking

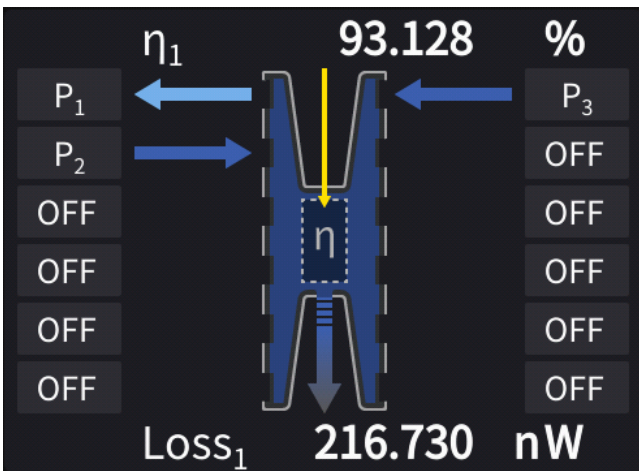

Efficiency: $\eta = \frac{|P_1|}{|P_2| + |P_3|} * 100$

Loss: $Loss = -|P_1| + |P_2| + |P_3|$

During normal operation

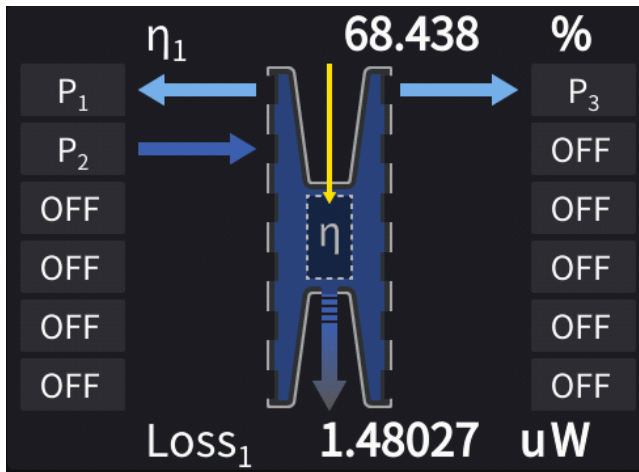

Efficiency: $\eta = \frac{|P1| + |P3|}{|P2|} * 100$

Loss: $Loss = -|P1| + |P2| - |P3|$

Displaying efficiency and loss

Display screen: **MEAS** key > **[VALUE]** > **[CUSTOM]**



- 1 Select the number of items to be displayed on the screen.
- 2 Tap the parameter name to open the window to set the basic measurement parameters.

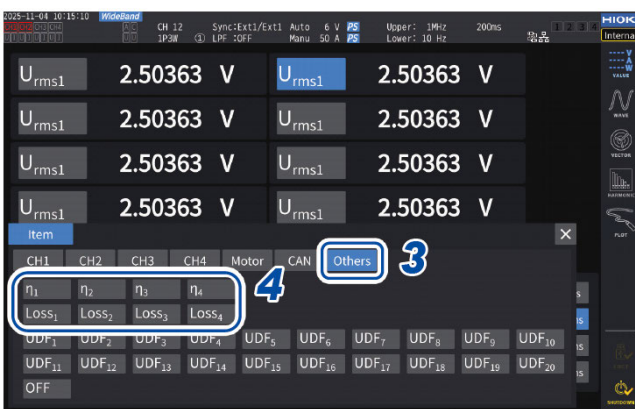

- 3 Tap **[Others]**.
- 4 Select one from among the following alternatives: **[η_1]** to **[η_4]** (efficiency) or **[Loss₁]** to **[Loss₄]** (loss).

3.6 Motor Measurement (Motor Analysis-Equipped Model)

The motor analysis-equipped model can perform motor analysis when used with an external torque sensor and tachometer. In addition, the motor input parts used in motor analysis can also be used as independent inputs, such as analog DC (up to two channels) or pulse (up to four channels), or waveform measurement triggers.

 See “Configuring the trigger settings” (p.156)

Motor measurement wiring

The motor analysis function can be used to measure torque, RPM, motor power, and slip by inputting the signals from torque sensors and tachometers, such as rotary encoders (incremental type).

In addition, the input parts can be used as two analog channels and two pulse input channels.

Connecting torque meters and tachometers

The motor analysis-equipped model has four input connectors (insulated BNC connectors) on the rear panel of the instrument.

Because each connector (labeled Ch. A through Ch. D) is insulated from the instrument itself and from each other, various types of sensors with differing ground potentials are connectable.

Ch. A, Ch. C	Analog DC, frequency, and pulse inputs
Ch. B, Ch. D	Frequency and pulse inputs

In addition to using the channels in combination for motor analysis, they can also be used as independent analog signal/pulse signal input channels.

WARNING

When connecting input terminals to Ch. A through Ch. D



■ Do not input a signal that exceeds the rating of any connector.

Doing so could cause damage to the instrument or cause it to overheat, resulting in serious bodily injury.



■ Turn off the instrument and other devices being connected before making any connections, and make sure the connections are secure.

Failure to do so could cause connectors to loosen and come into contact with other conductive parts, resulting in bodily injury and damage to the equipment.

CAUTION

- **When disconnecting cables, disengage the lock and then pull out the BNC connector while gripping it at the connection (do not pull on the cable).**

Failure to do so could damage the BNC connector.

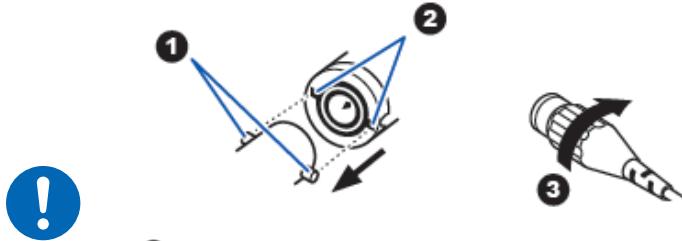

- ① Lugs on the instrument's input terminal
- ② BNC connector's slots
- ③ Lock

- **Use the L9217 Connection Cord (plastic) for connection with an isolated BNC connector (plastic). Use the 9165 Connection Cord (made of metal) with metal BNC connectors.**

If a metallic BNC cable is connected with an isolated BNC connector, the isolated BNC connector, the instrument, or connected devices may be damaged.

To connect torque meters and tachometers

Necessary items: L9217 Connection Cord (necessary quantity), device to be connected (such as torque sensor and tachometer)

- 1** Verify that the instrument and the device being connected have been turned off.
- 2** Connect the device's output terminal to the instrument with a connection cord.
[See "Connection examples of motor analysis" \(p.127\)](#)
- 3** Turn on the instrument.
- 4** Turn on the connected devices.

Connection method

There are several different operating modes and connection patterns available for the motor inputs.

Display screen: **INPUT** key > **[MOTOR]**

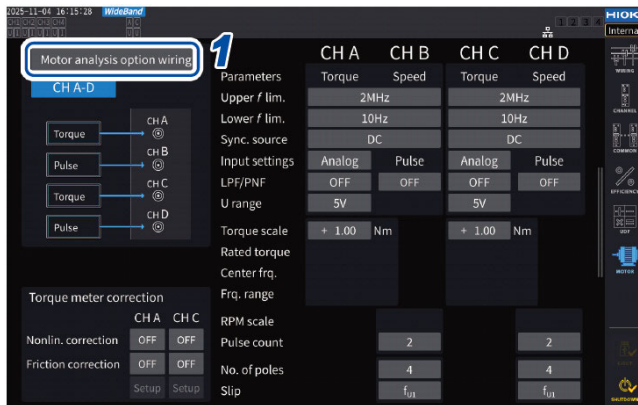

1 Tap **[Motor analysis option wiring]** to open the settings window.

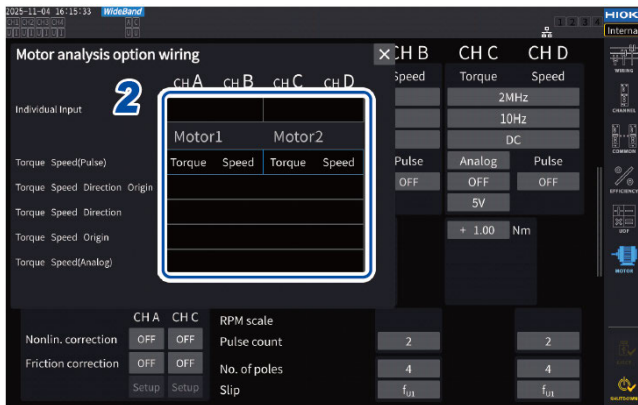

2 Select the operation mode for the motor analysis option channels.

[Individual input] mode

The motor inputs can be used as independent analog DC inputs or as pulse inputs.

Operating mode	Applicable channels	Description
Individual Input	AB, CD	For measuring voltage signals and pulse signals

Use this mode to measure and display the signal from a voltage-output sensor, or to measure the frequency of a pulse input and display the waveform.

Motor analysis mode

This mode can analyze motors performances by measuring signal inputted from torque sensors and tachometers.

Connection pattern	Applicable channels	Description
Pattern 1 Torque, Speed (Pulse)	AB, CD Simultaneous analysis of up to two motors	Motor analysis based on inputs of torque signal and RPM pulse signal
Pattern 2 Torque, Speed, Direction, Origin	ABCD	Motor analysis based on inputs of torque signal, RPM pulse signal, rotational direction signal, and origin signal
Pattern 3 Torque, Speed, Direction	ABCD	Motor analysis based on inputs of torque signal, RPM pulse signal, and rotational direction signal

3.6 Motor Measurement (Motor Analysis-Equipped Model)

Pattern 4 Torque, Speed, Origin	ABCD	Motor analysis based on inputs of torque signal, RPM pulse signal, and origin signal
Pattern 5 Torque, Speed (Analog)	ABCD	Motor analysis based on inputs of torque signal and RPM analog DC signal

- Pattern 1 is a mode that can analyze motors using a pair of adjacent channels. Motor power and motor efficiency can be measured for up to two systems simultaneously.
- Patterns 2, 3, 4 and 5 are modes that can analyze motors using a combination of four channels. These patterns permit more advanced analysis, measuring not only motor power and motor efficiency, but also rotational direction and regeneration/power running in combination, or electrical angle measurement. Furthermore, these patterns allow for measurement based on one motor revolution (one cycle of the mechanical angle).
- When inputting the origin (Z-phase pulse) signal in motor analysis mode, always input the pulses outputted from the same encoder. If the order of the RPM pulse signal's rising edges and the origin signal's rising edges reversed, RPM measurement may become unstable.
- When taking measurement using a pulse as a reference for motor analysis, use a signal with the number of pulses that is an integer multiple of the number of motor pole pairs (which is half the total number of poles in the motor).
[🔍 See "Synchronization source" \(p.91\)](#)
- In an electrically noisy environment, ground the instrument and the connected sensors at the same electric potential.

Motor analysis option wiring

	Ch. A	Ch. B	Ch. C	Ch. D
Individual Input	Indiv.	Indiv.	Indiv.	Indiv.
	Motor 1		Motor 2	
Torque Speed (Pulse)	Torque	Speed	Torque	Speed
Torque Speed Direction Origin	Torque	Speed	Direction	Origin
Torque Speed Direction	Torque	Speed	Direction	OFF
Torque Speed Origin	Torque	Speed	OFF	Origin
Torque Speed (Analog)	Torque	OFF	Speed	Off

Connection examples of motor analysis

In these examples, a torque meter and a tachometer are being connected with Ch. A to Ch. D.

Example 1: Motor power measurement (settings of motor analysis mode pattern 5)

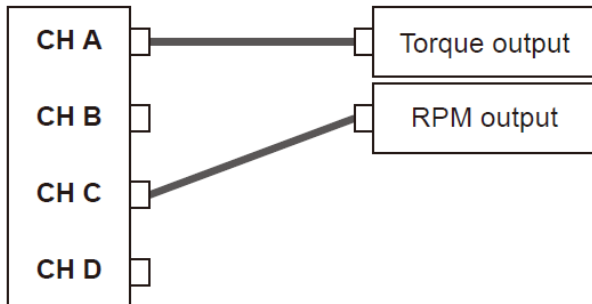

Input the torque signal to Ch. A and the RPM signal to Ch. C. Then measure the motor power and motor efficiency.

The torque signal can use an analog DC signal or pulse-based frequency input.

The RPM signal must be an analog DC signal.

The torque signal and RPM signal can be inputted from different sensors.

Example 2: Motor power measurement with forward/reverse detection (setting of motor analysis mode pattern 3)

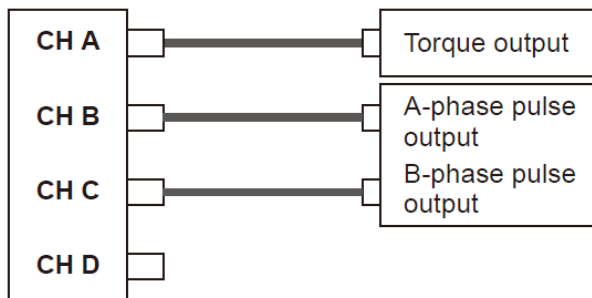

Input the torque signal to torque output Ch. A, the A-phase pulse signal to Ch. B, and the B-phase pulse signal to Ch. C. Then measure the motor power and motor efficiency while viewing the direction of the motor's rotation based on the phase difference between the A-phase pulse and the B-phase pulse.

The torque signal can use an analog DC signal or pulse-based frequency input.

Example 3: Motor power measurement with electrical angle measurement (settings of motor analysis mode pattern 2)

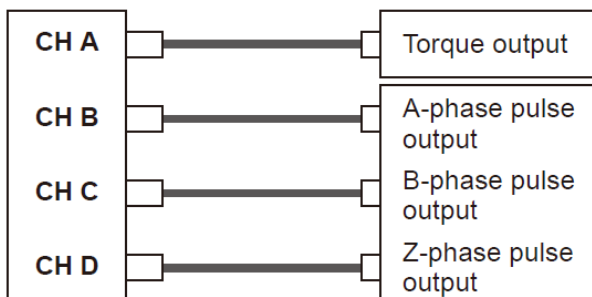

Input the torque signal to Ch. A, the A-phase pulse signal to Ch. B, the B-phase pulse signal to Ch. C, and the Z-phase pulse (origin) signal to Ch. D. Then measure the motor power and motor efficiency while measuring the electrical angle.

By setting the synchronization source to Zph., you can synchronize measurement to the mechanical angle instead of the electrical angle.

The torque signal can use an analog DC signal or pulse-based frequency input.

If you do not need to detect the direction of the motor's rotation, it is not necessary to input the B-phase pulse to Ch. C, and you can select pattern 4 instead.

When using Zph. as the synchronization source, you need to input not only the Z-phase pulse to Ch. D, but also the A-phase pulse to Ch. B.

Example 4: Motor power measurement (settings of motor analysis mode pattern 1)

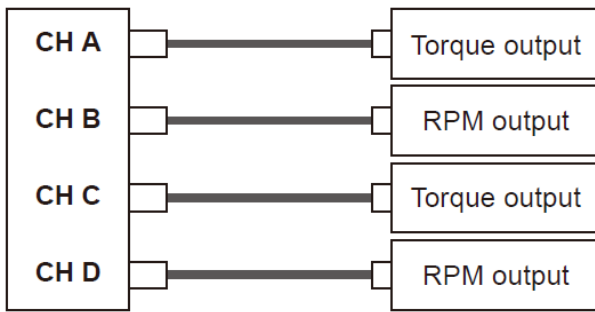

Input the torque signal and the RPM signal to Ch. A and Ch. B to measure the motor power and motor efficiency of the first system. Input the torque signal and the RPM signal to Ch. C and Ch. D to measure the motor power and motor efficiency of the second system. The torque signal can use an analog DC signal or pulse-based frequency input. Only pulse-based RPM signal can be input.

Configuring connected motor input settings and displaying measured values

For details about the display of measured values and the settings for inputting signals, see “3.6 Motor Measurement (Motor Analysis-Equipped Model)” (p.123).

Displaying measured motor values

Displaying measured motor values on the [BASIC] screen

Display screen: **MEAS** key > **[VALUE]** > **[BASIC]**

```
CH A Analog Sync:U1 5 V LPF: OFF Upper: 2MHz Lower: 10 Hz 200ms
CH C Analog Sync:U1 5 V LPF: OFF Upper: 2MHz Lower: 10 Hz
```

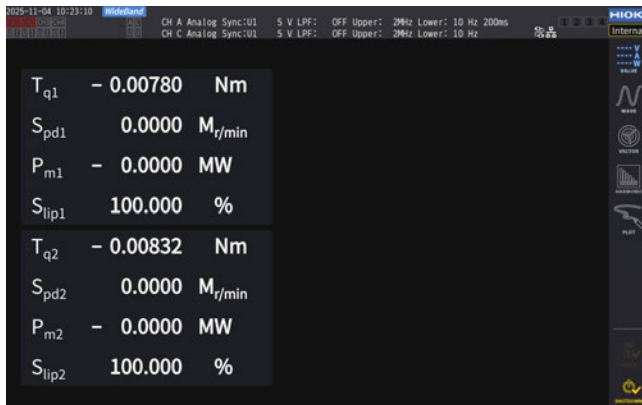

1 Press the ◀ CH ▶ keys for channel selection to switch the display to [A-D].

The displayed channel will change each time the ◀ CH ▶ keys are pressed. All measured motor values that can be displayed according to the settings will be displayed.

When [A-D] is displayed, the following displays will appear at the top of the screen.

Input of Ch. A and Ch. C	The top row indicates the input settings for [CH A], and the bottom row indicates that for [CH C]. [Analog], [Freq], or [Pulse] is displayed.
Synchronization source for motor input	Displays the source settings that determine the period (between zero-crossing points) that serves as the basis for measurement. Depending on the connection setting of the motor analysis option, the sources will be displayed in the top and bottom rows.
Filter settings	The top row indicates the range and filter for [CH A], and the bottom row indicates those for [CH C]. For the [Analog] setting, the range and filter setting values will be displayed. For the [Freq] and [Pulse] settings, the filter setting values will be displayed.

3.6 Motor Measurement (Motor Analysis-Equipped Model)

Displaying selected measured motor values on the [CUSTOM] screen

Display screen: **MEAS** key > **[VALUE]** > **[BASIC]**



1 Tap **[Motor]**.

2 Select items you want to display.

Tq	Torque value
Spd	RPM
Pm	Motor power
Slip	Slip

Zero adjustment of motor input

In the following circumstances, perform zero adjustment to eliminate errors caused by input signal offsets:

- When an analog DC voltage is inputted to Ch. A and Ch. C
- When frequency-based torque signal is input

In the following circumstances, perform zero adjustment while the instrument is receiving zero input for the torque and RPM signals:

- When a torque value is displayed even though no torque signal is generated
- When an RPM value is displayed even though no rotation signal is generated

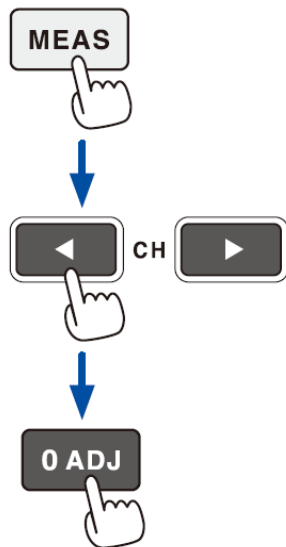

- 1** Press the **MEAS** key.
- 2** Use the **◀ CH ▶** keys for channel selection to switch the display to **[A-D]**.
The displayed channel will change each time the **◀ CH ▶** keys are pressed.
- 3** Press the **0 ADJ** key.
A confirmation dialog box is displayed.
- 4** Tap **[Yes]**.
Zero adjustment is started.

- When the **[A-D]** channel indicator is lit up, you can also perform motor input zero adjustment by pressing the **0 ADJ** key even on any page of the Measurement screen.
- Zero adjustment is unavailable for channels with the input setting set to **[Pulse]**.
- For channels with the input setting set to **[Frequency]**, input the set frequency signal for **[Center frq.]**. Zero adjustment is performed with **[Center frq.]** as the zero reference.
- Zero adjustment can be performed within an input range of $\pm 10\%$ of range. Inputting out-of-range signals cause zero-adjustment to fail.

Configuring the motor input settings

Connect torque sensors and tachometers by referring to “Motor measurement wiring” (p.123). Configure the motor analysis settings based on those connections.

Display screen: **INPUT** key > **[MOTOR]**

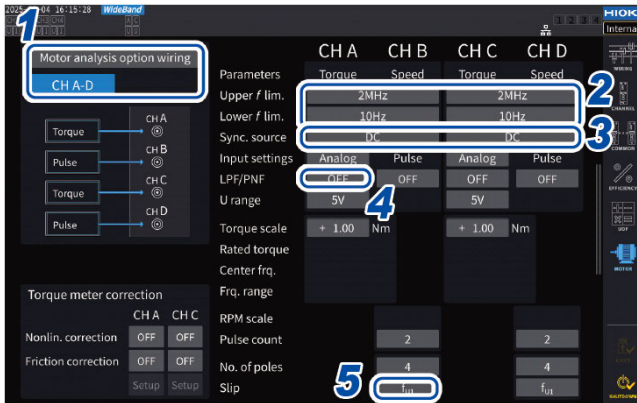

1 Tap **[Motor analysis option wiring]** to select.

2 Tap the **[Upper f lim.]** and **[Lower f lim.]** box and select the frequency from the list.

Set this when pulses are to be input for the motor input.

Upper f lim.	100 Hz, 500 Hz, 1 kHz, 5 kHz, 10 kHz, 50 kHz, 100 kHz, 500 kHz, 1 MHz, 2 MHz
Lower f lim.	0.1 Hz, 1 Hz, 10 Hz, 100 Hz

Upper frequency limit

This setting specifies the lowest frequency that exceeds the maximum frequency of the input pulse signal. When **[Motor analysis option wiring]** is set to **[Individual Input]**, the setting is used as the upper limit for D/A output.

When using motor analysis mode, this setting is used as the pulse frequency that is used to display RPMs and motor powers and as a pulse frequency to calculate the upper limit value for the D/A output.

$$(\text{RPM upper limit value}) = \frac{60 \times (\text{Set upper frequency limit})}{(\text{Pulse count setting})}$$

$$(\text{Motor power upper limit value}) = (\text{Maximum torque value}) \times \frac{2 \times \pi \times (\text{RPM upper limit value})}{60}$$

If the input RMS signal setting is **[Analog]**, the RMS upper limit is calculated by multiplying the scaled RMS value by the voltage range value.

Lower frequency limit

This setting specifies the lower frequency limit for measurement of the input pulse signal.

When the following synchronization sources are selected, the lower limit frequency is also used as the lower frequency limit for measurement.

Ext1, Ext2
Zph1
Ch. B, Ch. D

3 Tap the **[Sync. source]** box to open the settings window.

Set the source that determines the period that serves as the basis for calculating motor analysis parameters.

Motor analysis parameters are measured using intervals of the source selected here.

🔍 See “Synchronization source” (p.91)

U1 to U4, I1 to I4, DC, Ext1 to Ext2, Zph1, Ch. B, Ch. D

When setting Ch. D to the origin signal (Origin), you can select **[Zph1]** as the synchronization source. The set motor synchronization source is displayed in **[Sync]** at the top of the screen when **[A-D]** is displayed via the **MEAS** key > **[Basic]** screen.

IMPORTANT

- When **[DC]** is selected as the synchronization source, segments will be matched with the data update interval.
(1 ms, 10 ms, 50 ms, 200 ms)
- When measuring motor efficiency under a fluctuating load, select the same synchronization source as that for the motor input measurement channel. Efficiency can be measured more accurately by using the same calculation interval for motor input and motor output.

4 Tap the **[LPF/PNF]** box and select a low-pass filter or pulse-noise filter from the list.

LPF	OFF (20 kHz), 1 kHz
PNF	OFF, Strong (100 kHz), Weak (1.8 MHz)

Low-pass filter (LPF)

Applicable channels

- Ch. A and Ch. C (when input is set to Analog DC)

Set the filter to **[1 kHz]** if external noise in analog DC input destabilizes measurement.

The LPF setting has no effect on input when input is not set to analog DC input.

Pulse-noise filter (PNF)

Applicable channels

- Ch. A and Ch. C (when input is set to **[Pulse]** or **[Frequency]**)
- Ch. B, Ch. D

Use this setting when the measured values for frequency or RPM data input using a pulse signal are unstable due to noise.

IMPORTANT

- This setting has no effect on channels for which the input is set to analog DC input.
- When the PNF is set to **[Weak (1.8 MHz)]**, pulses of approx. 1.8 MHz or higher will not be detected; when it is set to **[Strong (100 kHz)]**, pulses of 100 kHz or higher will not be detected.

5 Tap the **[Slip]** box and then select an input frequency source from the list.

3.6 Motor Measurement (Motor Analysis-Equipped Model)

This sets the frequency of the measurement channel inputted to the motor in order to calculate the motor's slip.

fU1, f1, fU2, f12, fU3, f13, fU4, f14

Slip equations

$$\text{When the unit is r/min} \quad 100 \times \frac{2 \times 60 \times (\text{input frequency}) - |\text{RPM}| \times (\text{setting value of the number of motor poles})}{2 \times 60 \times (\text{input frequency})}$$

Select the voltage or current supplied to the motor, whichever is more stable, as the input frequency source.

Setting the torque input

Select the type of signal used by the torque sensor connected to the instrument.

Analog	For sensors that output a DC voltage signal proportional to the torque
Frequency	For sensors that output a frequency signal proportional to the torque

The setting parameters vary with the selected input setting as follows.

When **[Analog]** is selected

When the torque input is set to **[Analog]**, set the scale value and unit together in **[U range]** and **[Torque scale]** according to the sensor.

Display screen: **INPUT** key > **[MOTOR]**

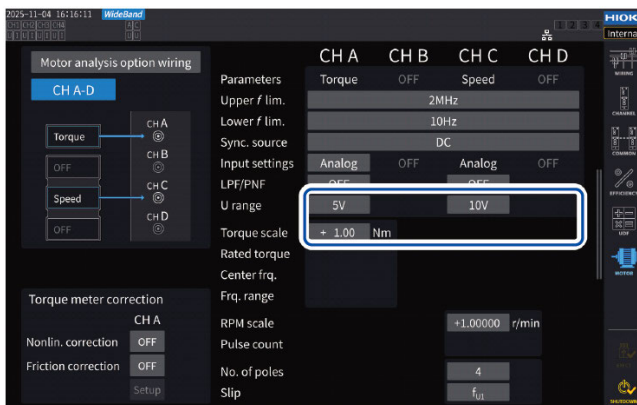

[U range]

Select a voltage range according to the output voltage of the torque sensor to be connected. When the A-D channel indicator is lit up, you can use the range keys to select a voltage range.

When A-D is lit up:

The **U RANGE** key functions for Ch. A; the **I RANGE** key functions for Ch. C.

1 V, 5 V, 10 V

[Torque scale]

You can use the numeric keypad window.

Measured torque values are displayed as the result of multiplying the input voltage by the scaling value. Set the torque value per 1 V of output from the connected torque sensor in conjunction with the unit-of-torque setting.

(Scaling value = Torque sensor rated torque value / Output full-scale voltage value)

In the example, the scaling value would be 50.

(50 = 500 N•m / 10)

-9999.99 to -0.01, 0.01 to 9999.99

Example: For a torque sensor with a rated torque of 500 N•m and an output scale of ±10 V

U range	10 V
Torque scale	50.00

When [Frequency] is selected

When the torque input is set to [Frequency], set the scale value and unit of measurement together in [Rated torque], [Center freq.], and [Frq. range] according to the sensor.

Display screen: INPUT key > [MOTOR]



[Rated torque]

Enter the rated torque of the torque sensor to be connected.

±0.01 m to 9999.99 k

[Center freq.], [Frq. range]

Enter the center frequency corresponding to a torque value of zero in the [Center freq.] box. Enter the difference between the frequency corresponding to the sensor rated torque and the center frequency in the [Frq. range] box.

1.000000 kHz to 500.0000 kHz

The settings must satisfy the following constraints:
 The center frequency plus the frequency range is less than or equal to 500 kHz.
 The center frequency minus the frequency range is more than or equal to 1 kHz.

Example 1: For a torque sensor with a rated torque of 500 N•m and output of 60 kHz ±20 kHz

Rated torque	500.00
Center Frq.	60.00000
Frq. range	20.00000

Example 2: For a torque sensor with a rated torque of 2 kN•m, positive rated torque of 15 kHz, and negative rated torque of 5 kHz

Rated torque	2.00 k
Center Frq.	10.00000
Frq. range	5.000000

Setting rotation signal input

Setting items of RPM signal input varies depending on the pattern of the motor analysis mode connection.

Analog	For a DC voltage signal proportional to the RPM
Pulse	For a pulse signal proportional to the RPM

The setting parameters vary depending on the setting.

When the input setting is set to [Analog]

Configure the voltage range and RPM scaling settings based on the rotation signal.

3.6 Motor Measurement (Motor Analysis-Equipped Model)

Display screen: **INPUT** key > **[MOTOR]**

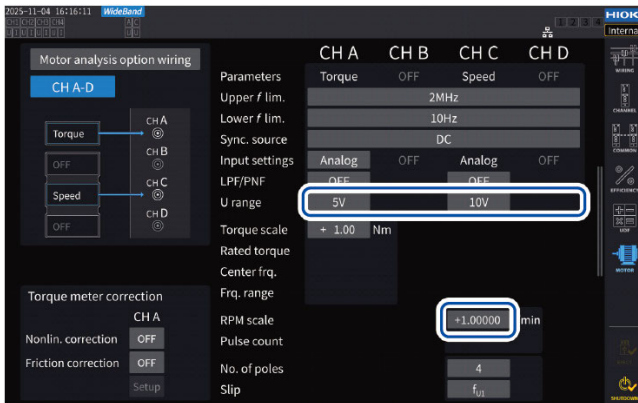

[U range]

Select a voltage range according to the output voltage of the rotation signal inputted to the instrument.

The voltage range of the rotation signal input can also be set using the current range keys while the **[A-D]** channel indicator is lit up.

1 V, 5 V, 10 V

[RPM scale]

You can use the numeric keypad window.

The result of multiplying the input voltage by the scaling value is displayed as the measured RPM value.

Enter the RPM per volt of the rotation signal output.

±0.00001 to 99999.9

When the input setting is set to **[Pulse]**

Display screen: **INPUT** key > **[MOTOR]**



[Pulse count]

If an incremental-type rotary encoder with 1000 pulses per rotation is connected, enter 1000.

You can use the numeric keypad window.

Specifying this parameter with a multiple of half of the motor's pole number setting will enable to select Ext as the synchronization source.

±1 to 60000
(number of pulses per mechanical angle rotation)

[No. of poles]

This value is used to perform slip calculation as well as convert the RPM signal into a frequency corresponding to the mechanical angle.

You can use the numeric keypad window.

2 to 254 (even number)

Torque meter correction function

Display screen: **INPUT** key > **[MOTOR]**



When the torque meter to be used provides calibration values, you can compensate for errors of the torque meter by entering the target values and calibration points.

There are two correction methods available: nonlinearity correction, which uses the Torque calibration point (N•m)-to-Torque calibration value (N•m) table, and friction correction, which uses the RPM calibration points (taking account of direction, r/min.)-to-Torque calibration value (N•m) table. You can use either one or both of them to perform compensation.

A correction table can contain value sets of up to 11 points.

The number of the calibration value sets (measured values and target values) can be set as desired. Entering all of 11 sets is not required.

Calibration values (target values) should be expressed in the unit same as the on-screen measured values. Measured values falling outside the correction table will not be corrected.

Input range of each value in the correction table: 0, ±1.00000 n to 999.999 T

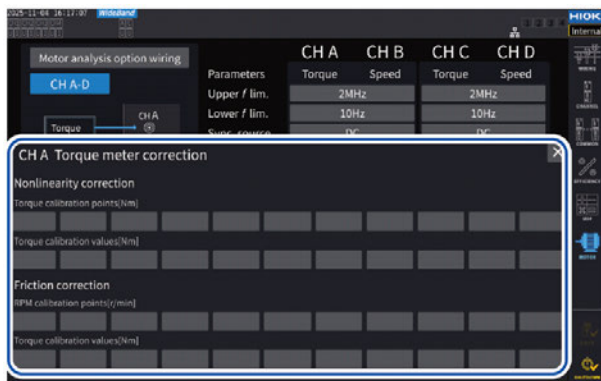

IMPORTANT

Motor input waveforms displayed on the waveform screen are not subject to the torque meter correction.

Nonlinearity correction: Torque calibration point (N•m)-to-Torque calibration value (N•m)

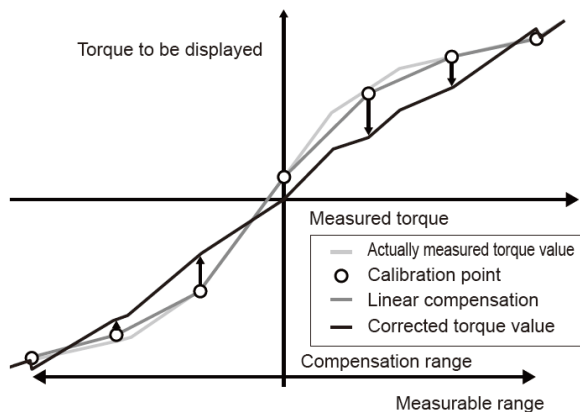

Friction correction (no-load output): RPM calibration points-to-Torque calibration value (N•m) (taking account of direction, r/min.)

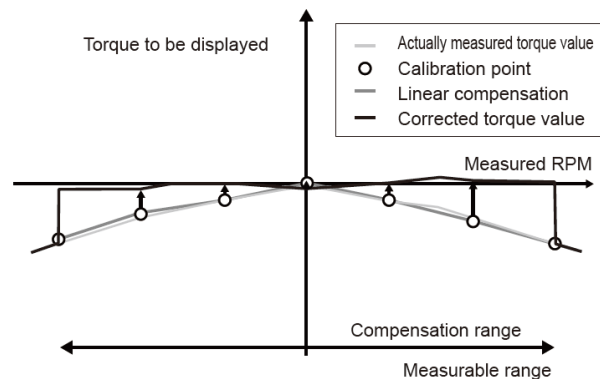

Equation

When the torque meter correction is enabled: Torque value = $S \times (X - \text{Zero-correction value}) - A_t - B_t$
 $A_t = atc - att^{*1}$
 $B_t = btc^{*1}$

- S: Scaling
- X: Input signal-to-torque converted value
- A_t: Nonlinearity correction value
- B_t: Friction correction value
- atc: Torque calibration value of nonlinearity correction table
- att: Torque calibration point of nonlinearity correction table
- btc: Torque calibration value of friction correction table

*1 Target values between the entered calibration points are calculated by linear interpolation.

- The calibration values should be obtained by the customer through calibration or contact the torque meter manufacturer.
- Zero adjustment of the motor analysis also applies to offsets of devices, including torque meters, regardless of whether the correction function is enabled or disabled.
- The instrument does not indicate about zero for a torque value outputted when no torque is generated or the motor is not rotating because it corrects measured values by applying calibration values after zero adjustment. Performing zero adjustment of this instrument sets the offsets of the entire system, including itself, to zero; thus, you should usually set the calibration value of the zero-torque point to zero.
- If you have torque meters' information on hysteresis characteristics or drift that occurs during a test, entering the calibration value of the zero-torque point will enable more accurate measurement.
- The unit of torque, newton-meter (N•m) in this section, varies depending on the setting.
- Calibration values for points that exceed the measuring range will not be used in the compensation calculation.
- When calibration values are expressed in % of full scale (% f.s.), the following equation can yield the calibration values you can enter. (Calibration value to be entered) = (f.s. of torque meter) × (% of full scale)
- Torque meter correction is valid only values within the range of set torque calibration points. If you want to correct torque values outside the range, set a wider range of torque calibration points.

Measuring the electric angle of the motor

When a pulse signal is used as rotation signal input, you can view changes in the voltage and current phase using the pulse as the reference by setting the **[Sync. source]** for input channels 1 to 4 to **[Ext1]** or **[Ext2]**.

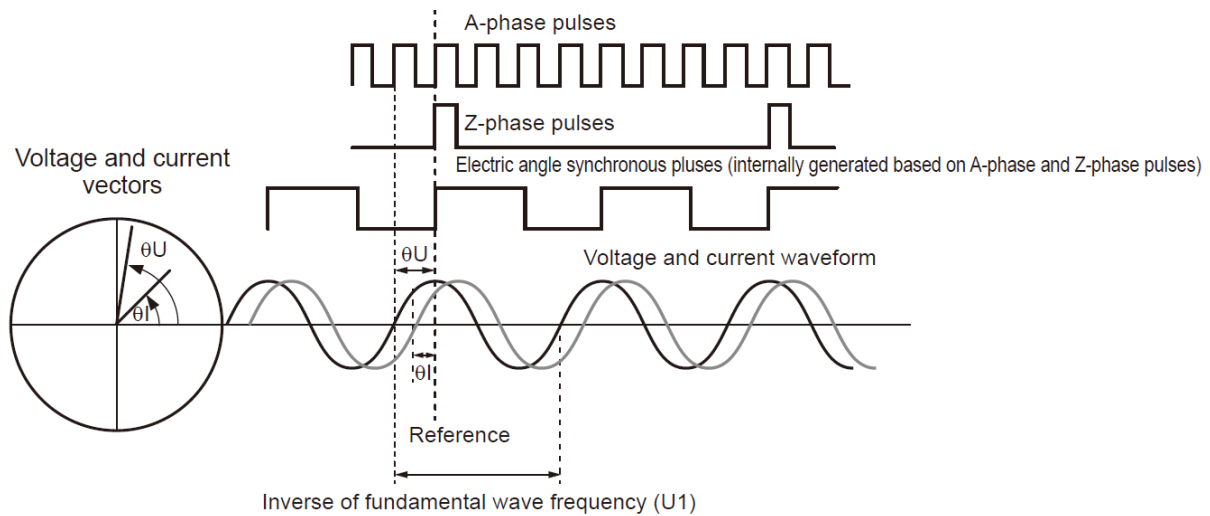

When measuring the electrical angle using multiple pulses

- It is recommended to use the origin signal (Z-phase). When the origin signal (Z-phase) is used, the reference pulse is determined based on the origin signal, enabling phase measurement using a fixed pulse as the reference at all times.
- To use a rising edge of the origin signal (Z-phase) as the reference, set the Z-phase reference to Rising. To use a falling edge of the origin signal as the reference, set the Z-phase reference to Falling.
- When the origin signal (Z-phase) is not used, the pulse that serves as the reference is determined during synchronization. If synchronization fails, a different pulse may be used as the reference each time resynchronization is performed.
- Performing harmonic analysis in synchronization with the inputted rotation signal pulse requires pulses, the number of which is a whole number multiple of the number of motor pole pairs. For example, a four-pole motor (2 motor pole pairs) would require pulses, the number of which is a whole number multiple of 2, while a six-pole motor (3 motor pole pairs) would require pulses, the number of which is a whole number multiple of 3.
- When measuring a motor that uses a Y connection internally in 3P3W3M wiring mode, phase angles of the phase voltage and phase current can be measured by using the Δ -Y conversion function.

Phase zero adjustment (PHASE ADJ)

This section describes how to compensate for the phase difference between the harmonic-measurement synchronization source's pulses and the voltage fundamental wave components of the connected first channel to zero.

3.6 Motor Measurement (Motor Analysis-Equipped Model)

Display screen: MEAS key > [VECTOR] > [VECTOR1]

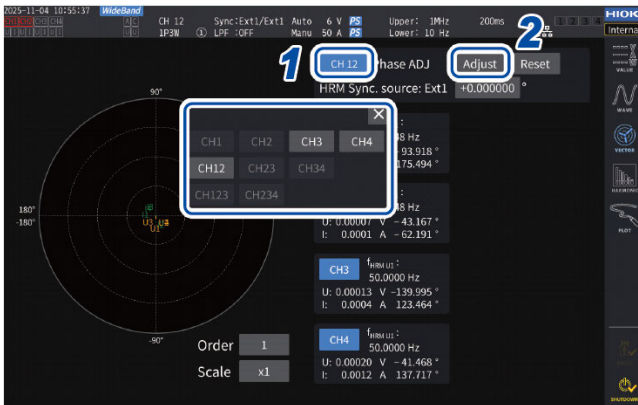

- 1 Select the channel for which you wish to perform phase angle zero adjustment using the channel selection window.
- 2 To obtain the compensation value according to the input, tap [Adjust] under [Phase ADJ].
- 3 To enter a user-defined compensation value, tap the compensation value display area and then enter the compensation value with the numeric keypad window.

- Phase zero-adjustment is available only when the synchronization source is set to [Ext1] or [Ext2]. It is unavailable with any other setting.
- The compensation value is undefined in a synchronization-unlocked condition.
- The compensation value has a valid setting range of -180° to $+180^{\circ}$. For the environments where phase angles are expressed as numbers between 0° and 360° , convert a compensation value into a number between -180° to $+180^{\circ}$ and enter it.
- The compensation display area indicates the present compensation value for the phase zero adjustment. Tapping [Adjust] can replace the existing compensation value with a new one.
- The set phase zero-adjustment compensation value will be subtracted from the measured pulse-based voltage- and current-phase values.
- Compensation values will be maintained even if the instrument is turned on or off.
- Tapping [Reset] will clear the compensation values and revert to operation in which the instrument displays the phase difference with the pulse being used as the reference.
- Compensation values will be cleared by the system reset.

Example of electrical angle measurement

- 1 Rotate the unenergized motor from the load side to measure the inductive voltage generated across the motor's input terminals.
- 2 Perform phase zero adjustment.
Zero adjustment will zero the phase difference between the fundamental wave component of the inductive voltage waveform inputted to U1 and the pulse signal.
- 3 Energize the motor to rotate it.
Voltage and current phase angles measured with the instrument will indicate an electrical angle based on the inductive voltage phase.

IMPORTANT

Because the phase difference includes the effects of the rotation input signal's pulse waveform and the instrument's internal circuit delay, it will appear as measurement error when the instrument measures a frequency that differs greatly from the frequency at which phase zero adjustment was performed.

Detecting the motor's direction of rotation

If an incremental-type rotary encoder's A-phase pulse and B-phase pulse are inputted to Ch. B and Ch. C input terminals, which are for the rotation signals, the instrument can detect the direction in which the shaft is rotating, assigning a corresponding polarity sign to the RPM values.

When **[Motor analysis option wiring]** is set to **[Torque Speed Direction Origin]** or **[Torque Speed Direction]**, the direction of rotation can be detected.

Direction of rotation is judged based on the level of the other's pulse (high/low) when rising and falling edges of the A-phase and B-phase pulses are detected.

Forward operation

RPM polarity: plus sign (+)

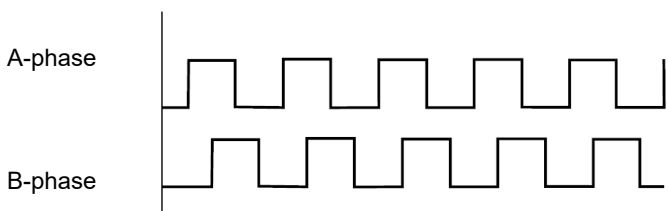

Backward operation

RPM polarity: minus sign (-)

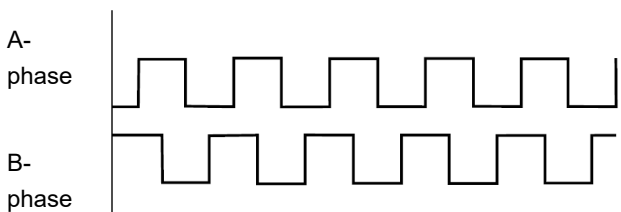

The detected direction of rotation affects the polarity sign assigned to measured RPM values as well as measured motor power (Pm) values.

When **[Motor analysis option wiring]** is set to **[Torque Speed Direction Origin]** or **[Torque Speed Origin]** and the synchronous sources from Ch. 1 to Ch. 4 are set to **[Zph1]**, the measured voltage and current based on one motor spinning (one mechanical angle cycle) are displayed.

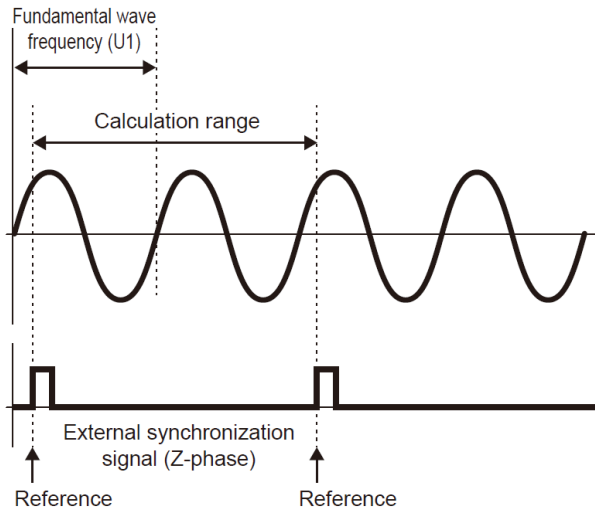
Example for a 4-pole motor

- To use a rising edge of the external synchronization signal (Z-phase) as the reference, set the Z-phase reference to Rising.
To use a falling edge of the external synchronization signal as the reference, set the Z-phase reference to Falling.
- Since one motor rotation is always used as the calculation range regardless of the number of poles the motor has, measurement can be performed by averaging the variations for each pole that are caused by the motor's mechanical characteristics.
- For measured values of voltage and current harmonic values, measured values of fundamental wave appear as the order of half the number of motor poles.
Subsequently, the n -th-order harmonics of voltage and current appear at the product of half the number of motor poles and n .
- The voltage and current fundamental frequencies are measured to obtain measured voltage and current frequency values.
- Provide input as appropriate based on measurement parameters of Ch. A through Ch. D. In addition to inputting the origin signal to Ch. D (Z-phase pulse), the rotation signals need to be correctly inputted to Ch. B (A-phase pulse) and Ch. C (B-phase pulse when the direction is used).
- To use other pulses as the calculation ranges' reference instead of pulses outputted from a rotary encoder, you are recommended to use in **[Indiv.]** operating mode of the motor analysis and set the synchronization source of input channels 1 through 4 to Ch. B or Ch. D, respectively. Input the reference pulses as the selected synchronization source.

3.7 Measuring IEC Voltage Fluctuation/Flicker (PW9006 option)

The instrument in IEC measurement mode can be used as a flicker meter in compliance with IEC61000-4-15, enabling flicker measurement.

The start of flicker measurement is linked with the start of integration.

In IEC measurement mode, internal calculation processing differs from the wideband measurement mode to realize measurements in compliance with the IEC standard. Thus, some functions are restricted in IEC measurement mode.

🔍 See “2.7 Measurement mode” (p.72)

IEC voltage fluctuation and flicker measurement can be enabled by adding the PW9006 IEC harmonic/flicker measurement function (optional).

🔍 See “11.12 Adding Optional Functions” (p.416)

Display screen: **INPUT** key > **[COMMON]**

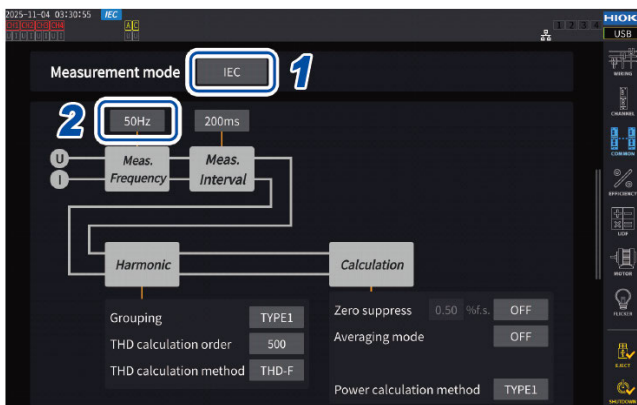

- 1 Set the **[Measurement mode]** to **[IEC]** measurement mode.
- 2 Tap the **[Meas. Frequency]** box to choose the measurement frequency.

50 Hz, 60 Hz

The transfer function of the flicker meter could be altered; thus, select an appropriate one.

IEC measurement mode

- The instrument in this mode can measure IEC harmonics and IEC voltage fluctuation/flicker.
- When the measurement line has a frequency of 50 Hz or 60 Hz, the instrument can perform harmonic measurements according to IEC61000-4-7 and voltage fluctuation/flicker measurements according to IEC61000-4-15.
- The data update interval is fixed at 200 ms.
- Accurately measured values for harmonic measurement and voltage fluctuation/flicker measurement cannot be guaranteed if the frequency to be measured falls outside the range of 45 Hz to 66 Hz.

Making the IEC flicker measurement settings

This section describes how to make the IEC flicker measurement settings.

Display screen: **INPUT** key > **[FLICKER]**

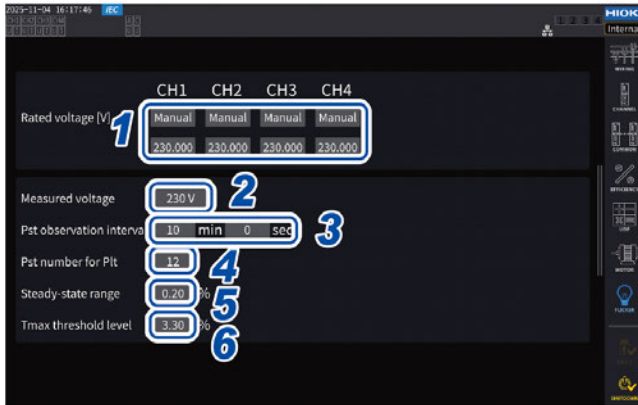

- 1 Tap the boxes of wiring configurations you want to set under **[Rated voltage]** to select the rated voltage.

Auto	Select to automatically set the rated voltage based on the previous input voltage.
Manual	Select to enter a value manually. Settable range: 0.001 to 999.999

- 2 Tap the **[Measured voltage]** box to set the voltage to be measured.
The transfer function of the flicker meter changes according to this setting; thus, select an appropriate one.

120 V, 230 V

- 3 Tap the **[Pst observation interval]** boxes to set the Pst observation interval.
Usually, set the observation interval to 10 minutes.

00 min 30 sec to 15 min 00 sec

- 4 Tap **[Pst number for Plt]** box to set the number of Pst intervals used for Plt calculation.
Usually, set the number of target Pst to 12.

1 to 1008

- 5 Tap **[Steady-state range]** to set the steady range (dmin: allowable range of relative voltage change regarded as a steady state).

0.10 to 9.99%

- 6 Tap the **[Tmax threshold level]** box to set the threshold value for Tmax evaluations.

1.00 to 99.99%

How to measure IEC flicker

To perform the IEC flicker measurement, you must set the wire configuration setting of the measurement target channel to 1P2W. The correct values will not be output if any other wiring configuration is selected. To initialize various filters, wait about 1 minute before starting measurements with the voltage input after the setting is completed.

The IEC flicker measurement is started in sync with the start of the integration and stopped at the completion of the Plt calculation. If the [Pst observation interval] and [Pst number for Plt] are set to 10 minutes and 12, respectively, the calculation will be stopped in 120 minutes, obtained by multiplying 10 minutes by 12 points. Note that the integration does not stop even after the flicker calculation stops. For detail about how to control integration, see “3.3 Integration Measurement” (p.98).

In IEC measurement mode, cumulative integration is not possible. It is necessary to reset the data once to start integration again after the integration is stopped.

Saving the measured values of flicker calculations requires saving data including that acquired after the Plt calculation is completed.

Measurement items	Description
d_c	Relative steady-state voltage change
d_{max}	Maximum relative voltage change
T_{max}	Period during which the relative voltage change exceeds the threshold
P_{st}	Short-term flicker value
P_{stMax}	Maximum short-term flicker value
P_{It}	Long-term flicker value
$P_{instMax}$	Maximum instantaneous flicker value
$P_{instMin}$	Minimum instantaneous flicker value

Displaying selected measured motor values on the [CUSTOM] screen

Display screen: MEAS key > [VALUE] > [CUSTOM]



- 1 Tap [Flicker].
- 2 Select items you want to display.

Description of measurement parameters

Flicker

Generally speaking, the term flicker is a directly visible change in brightness of a light source. If a heavy-load facility starts up or a large current flows due to a temporary overload, each facility is affected by a voltage drop, resulting in a flicker.

In lighting loads, it primarily refers to the flashing of lighting fixtures. Discharge lamps, such as fluorescent lamps and mercury lamps, are particularly susceptible to the effects of voltage drops. As the frequency of briefly darkening due to voltage drops increases, flickers will repeatedly occur, making people very uncomfortable visually.

Short-term flicker (P_{st})

This value indicates susceptibility to a flicker measured in a short period. Any P_{st} measuring period can be set; however, it is generally set at 10 minutes.

Long-term flicker value (P_{lt})

This value indicates susceptibility to a flicker measured in a long period using consecutively obtained P_{st} values. Any number of P_{st} to be calculated can be set; however, it is usually calculated from twelve P_{st} values (two hours when the P_{st} is observed for 10 minutes).

Instantaneous flicker value (P_{inst})

This value is obtained by performing various filter processing, including the visibility filter for the input waveform.

Steady state

The voltage RMS value for each half cycle remains within the specified $\pm 0.2\%$ allowable band for approximately 1 s or more, considered stable.

Relative steady-state voltage change (d_c)

This value is a difference between two consecutive stationary values. This value is obtained by dividing the difference between the two steady voltages before and after a single voltage fluctuation by the rated voltage, expressed in percent.

Maximum relative voltage change (d_{max})

This value is obtained by dividing the absolute value of the most significant fluctuation value in onetime voltage fluctuation by rated voltage based on the previous steady-state value, expressed in percent.

Period while the relative voltage change exceeds the threshold level (T_{max})

This value indicates the period while the relative voltage change is exceeding the threshold level during one voltage change period. Any threshold level can be set; however, it is generally set at 0.20%.

3.7 Measuring IEC Voltage Fluctuation/Flicker (PW9006 option)

4 Displaying Waveforms

The instrument can display voltage, current measured on all channels and motor input waveforms. The waveform display is completely independent of power measurement. The operation described in this chapter will not affect measured power or harmonics values.

4.1 Waveform Display Method

Displaying waveforms on the waveform (WAVE) screen

The waveform screen displays only waveforms.

Starting waveform recording

Display screen: **MEAS** key > **[WAVE]** > **[WAVE]**

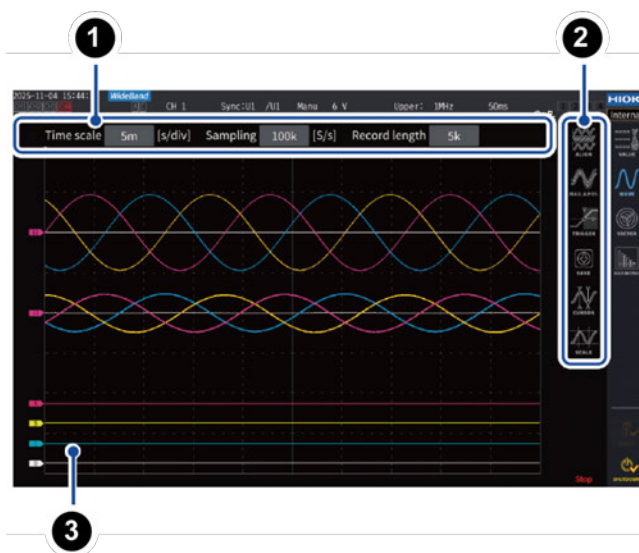

- 1 Settings area
- 2 Setup menu area
- 3 Measured value display area

Waveform recording status display

The waveform recording status display provides helpful information if it takes time for the instrument to display waveforms or if waveforms cannot be displayed.

- 1 Press the **RUN/STOP** key.

RUN / STOP (Lit up in green)

Waveform recording begins, and the screen display is updated. Recording will start when a trigger is activated.

See "4.3 Recording Waveforms" (p.159)

- 2 Press the **RUN/STOP** key again.

RUN / STOP (Lit up in red)

Waveform recording stops, and the screen display is no longer updated.

4.1 Waveform Display Method

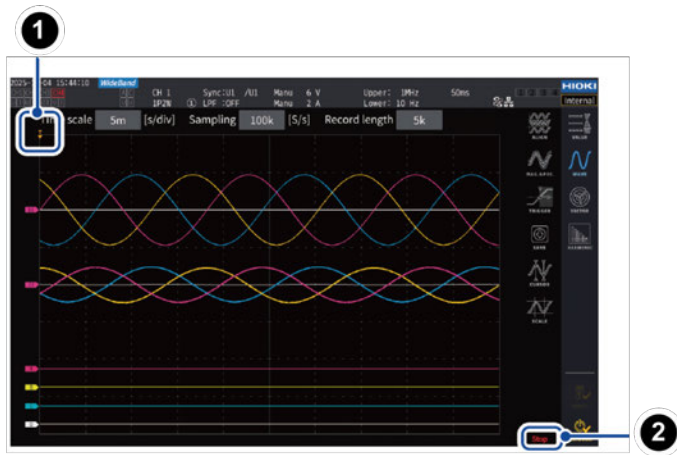

- 1 Start trigger (p.156)
- 2 Waveform recording status

Stop	Recording has stopped.
PreTrig.	The instrument is recording pre-trigger waveforms.
Trigger	The instrument is in the trigger standby state.
Storage	The instrument is recording post-trigger waveforms.
Compress	The instrument is creating waveforms for display.
Abort	The instrument is performing processing to stop waveform recording.

Displaying waveforms and measured values on the waveform and measured value (WAVE+VALUE) screen.

This screen displays waveforms and measured values. The timing between when on-screen waveforms were recorded and when on-screen values were measured are not synchronized.

Starting waveform recording

Display screen: **MEAS** key > **[WAVE]** > **[+VALUE]**

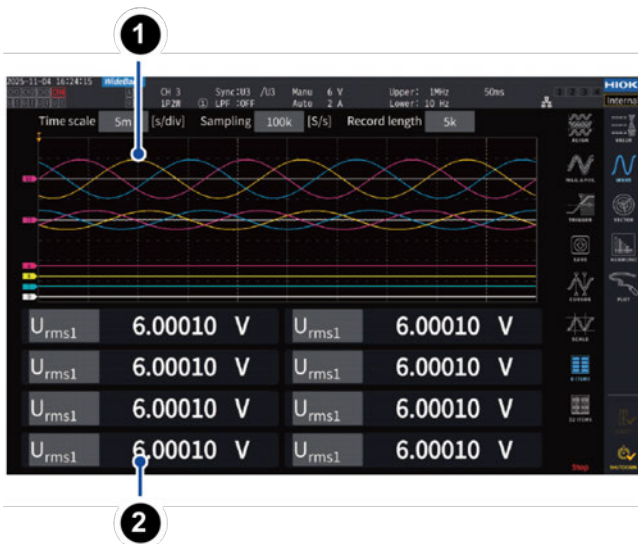

- 1 Waveform display area
- 2 Measured value display area

Aligning waveforms

There are four patterns available to align waveforms.

The measured values display area can display 32 freely-selected basic measurement parameters.

See “1.4 Basic Operation (Screen Display and Layout)” (p.37).

To stop display updating of measured values

Pressing the **HOLD** key can stop display updating of measured values. Waveform recording is not stopped.

Display screen: **MEAS** key > **[WAVE]**

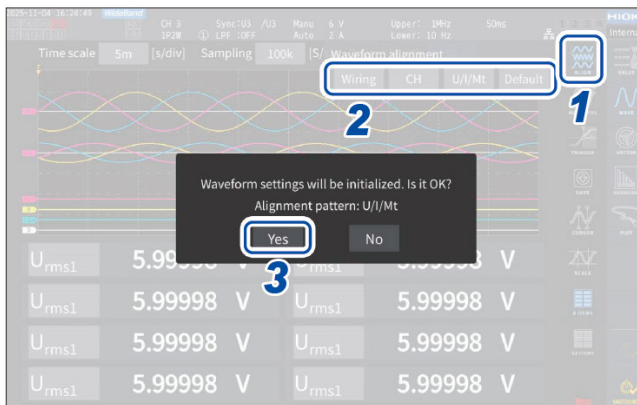

- 1 Tap **[ALIGN]**.
- 2 Tap any one of the **[ALIGN]** patterns.
A confirmation dialog box is displayed.
- 3 Tap **[Yes]** to align the waveforms.

Wiring	Places waveforms of the same wiring configuration at the same position. The positions differ according to the wiring configuration.
Channel	Places waveforms of the same channel at the same position.
U/I/Mt	Places waveforms in the order of voltage, current, and motor from the top.
Default	Places waveforms separated into (1) voltage and current waveforms and (2) motor waveforms. If the motor analysis option is not installed, voltage and current waveforms are centrally located.

The vertical axis of the waveforms is positioned relative to the zero positions of each input.

- The vertical axis display magnification is adjusted to match the vertical axis size of the range and area.
- When waveforms are aligned, the colors of the waveforms are also changed. Colors differ depending on the alignment pattern.

4.2 Changing the Waveform Display and Configuring Recording

Time axis setting

This section describes how to configure the waveform time axis settings using the [Time scale], [Sampling], and [Record length]. The time axis settings are automatically changed according to sampling speed and record length settings.

Display screen: **MEAS** key > [WAVE] > [WAVE]

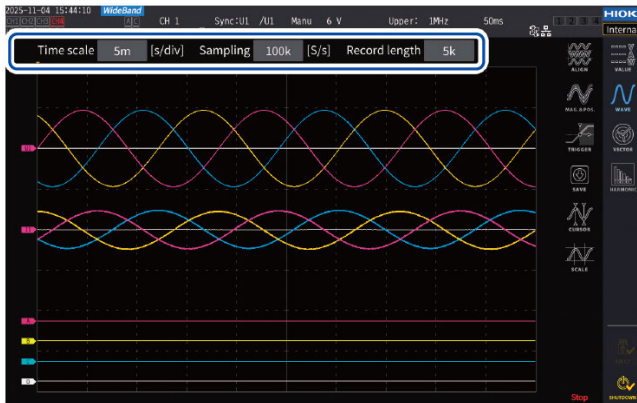

Tap each box and then rotate the X rotary knob to set each setting items.

See “Changing values with rotary knobs” (p.38)

IMPORTANT

Motors' analog waveforms are sampled at a maximum rate of 1 MS/s. For the sampling speed setting of 1 MS/s or faster, the same value is supplementary displayed at points between sampling points.

Time axis

Sampling speed and recording length settings are changed in conjunction with the time axis setting. The sampling speed and recording length change to the settings to be updated at the shortest interval (highest sampling speed, shortest recording length) among the time axis settings combinations determined by sampling frequencies and recording lengths.

40 μ s/div, 100 μ s/div, 200 μ s/div, 400 μ s/div, 500 μ s/div, 1 ms/div, 2 ms/div, 4 ms/div, 5 ms/div, 10 ms/div, 20 ms/div, 40 ms/div, 50 ms/div, 100 ms/div, 200 ms/div, 400 ms/div, 500 ms/div, 1 s/div, 2 s/div, 4 s/div, 5 s/div, 10 s/div, 20 s/div, 50 s/div

Sampling speed

2.5 MHz, 1 MHz, 500 kHz, 250 kHz, 100 kHz, 50 kHz, 25 kHz, 10 kHz

Recording length

1 k, 5 k, 10 k, 50 k, 100 k, 500 k, 1 M, 5 M (unit of measurement: words)

1 k = 1000 sampled data point, 1 sampled data point = 1 word

The waveforms are displayed once data has been recorded for the set recording length with the specified sampling speed.

If the time scale setting is set to slower than 200 ms/div, the waveforms are displayed as they are recorded in real time (roll mode).

Peak-to-peak compression

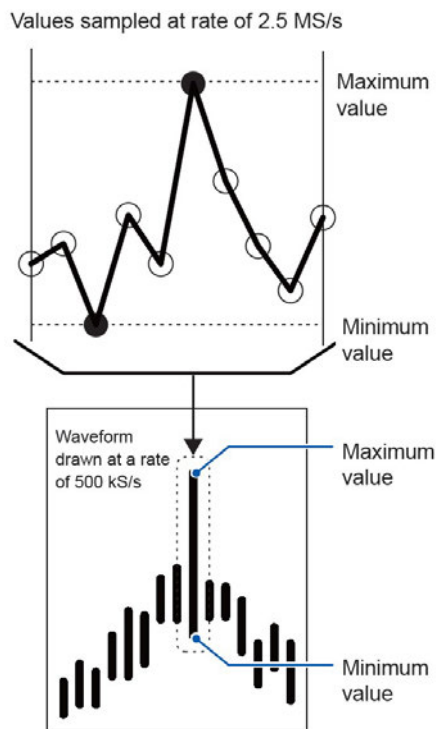

To compress a waveform sampled with a rate of 2.5 MS/s to that composed of points with a rate of 500 kS/s by using the peak-to-peak compression

Even if you change the sampling speed setting, the instrument samples signals internally with a sampling rate of 2.5 MS/s.

When reducing the sampling speed, the decimation of sampling points from a waveform sampled with the rate of 2.5 MS/s at regular intervals may decimate the maximum and minimum values in the interval. The peak-to-peak compression is the way to select and decimate other points leaving the maximum and minimum values in the interval.

In this way, you can reduce the sampling speed maintaining accurate waveforms that preserve the peaks of the uncompressed waveforms.

The waveform data to be saved consists of two values per data point, the maximum and minimum values as illustrated in the figure on the left.

Aliasing

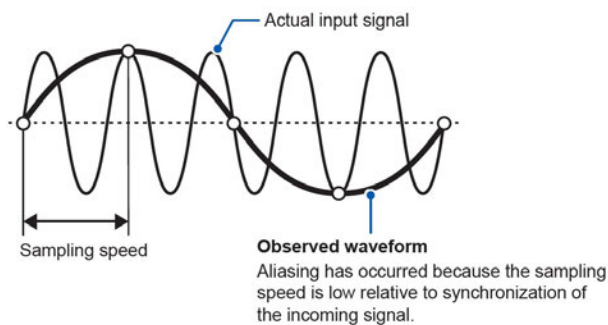

When the change of a signal under measurement becomes faster with respect to the sampling speed, slow signal changes that do not exist at a certain frequency are recorded.

This phenomena is called "aliasing".

Vertical axis zoom factor and display position settings

This section describes how to set display preferences, including choosing to disable or enable the waveform display setting, the vertical axis zoom factors, and display positions for each parameters.

Display screen: **MEAS** key > **[WAVE]** > **[WAVE]**

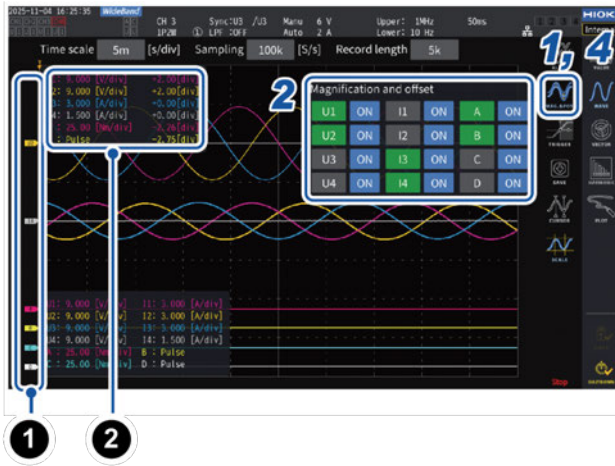

1 Tap **[MAG.&POS.]**.
The settings window for the vertical axis zoom factor and display position is displayed.

2 Tap a channel button.
The button of selected channel button turns green and the X and Y rotary knobs light up in green.
Multiple channel numbers can be selected simultaneously.

U	Voltage waveforms
I	Current waveforms
A to D	Motor input waveforms

- 1** The parameter name for each waveform will be displayed.
- 2** The div. display ranges and display positions for the parameter being changed will be displayed.

3 Configure the settings by rotating the X rotary knob and Y rotary knob.

The vertical axis zoom factor and vertical axis display position settings change in response to the knobs rotated.

Vertical axis zoom factor

$\times 1/10, \times 1/9, \times 1/8, \times 1/7, \times 1/6, \times 1/5, \times 1/4, \times 1/3, \times 2/5, \times 1/2, \times 5/9, \times 5/8, \times 2/3, \times 5/7, \times 4/5, \times 1, \times 10/9, \times 5/4, \times 4/3, \times 10/7, \times 5/3, \times 2, \times 20/9, \times 5/2, \times 10/3, \times 4, \times 5, \times 20/3, \times 8, \times 10, \times 25/2, \times 50/3, \times 20, \times 25, \times 40, \times 50, \times 100, \times 200$

Vertical axis display position

-9999.99 div to 9999.99 div

- 4** Tap **[MAG.&POS.]** or the area out of the window.
The window closes.

Vertical axis zoom list display

The instrument can list the vertical axis magnifications of all waveforms.

Display screen: **MEAS** key > **[WAVE]** > **[WAVE]**

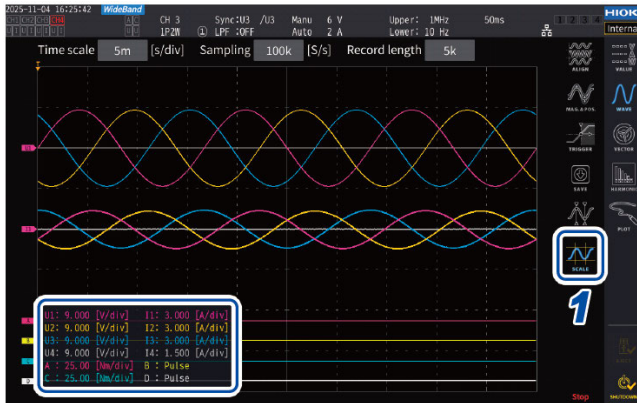

1 Tap **[SCALE]**.

The settings list window of the vertical axis zoom factors are displayed. Only the information of the on-screen waveforms is displayed in the window.

2 Tap **[SCALE]** again.

The settings list window of the vertical axis zoom factor closes.

Configuring the trigger settings

This section describes how to set conditions where the instrument can start waveform recording, called the trigger function.

When the user-defined trigger conditions are satisfied, a trigger is activated, starting waveform recording.

Display screen: **MEAS** key > **[WAVE]** > **[WAVE]**

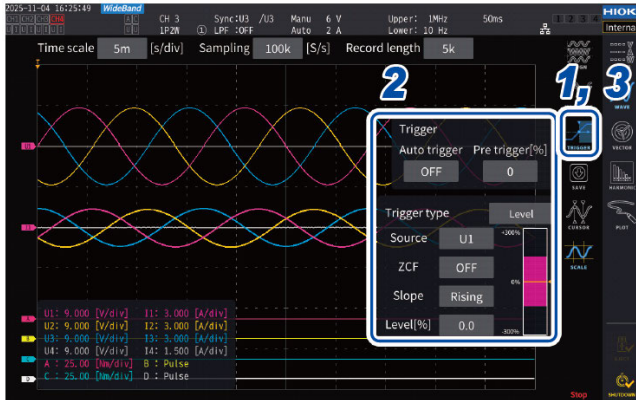

1 Tap **[TRIGGER]**.
The trigger setup window will be displayed.

2 Tap the button.
You can set the relevant items.
For details on each setup parameter, see “Description of parameter settings and selectable ranges” (p.156).

3 After completing the setup, tap **[TRIGGER]** or the area out of the window.
The trigger setup window will close.

Description of parameter settings and selectable ranges

Item	Settings	Description
Auto trigger	ON	Waveform recording will be forcibly started if the next trigger is not activated within about 100 ms after the activation of the previous trigger. This setting is useful to observe DC input waveforms.
	OFF	Waveform recording starts only when the set condition is met.
Pre-trigger	0% to 100% (Can be set in 10 percent points increments.)	<p>Sets how much of the waveform to allocate before the trigger is activated, relative to the recording length.</p> <p>Configure the settings by rotating the X rotary knob. See “Changing values with rotary knobs” (p.38)</p>

Item	Settings	Description
Trigger type	Level	Changes in a storage waveform level activate the trigger. Advanced settings of the level trigger can be configured.
	Event	Changes in the value of a selected measurement parameter activate trigger. Advanced settings of the event trigger can be configured.
Source	Sets the waveform to use as the trigger source.	
	U1 to U4	Voltage waveforms
	I1 to I4	Current waveforms
	Ch. A to Ch. D, Ext1 to Ext2	Motor waveforms (available only for motor analysis-equipped model) Available settings vary with the motor input operating mode.
ZCF (Zero-cross filter)	ON, OFF	<p>This function can eliminate noises of a waveform used as the trigger source by a noise filter when the trigger source setting is set to voltage waveform or current waveform.</p> <p>Set to [ON] to obtain stable trigger timing when using a waveform containing noise.</p> <p>This setting is particularly effective to observe PWM waveforms. This does not affect the display waveform.</p> <p>If [Source] is set to Ch. A to Ch. D or Ext1 to Ext2, the ZCF is forcibly disabled.</p>
Slope	Rising	The trigger will be activated at a rising edge of the waveform.
	Falling	The trigger will be activated at a falling edge of the waveform.
Level	-300% to +300%	<p>Sets the level at which the trigger is activated using [%] of the source range. A level monitor appears on the right side of the window.</p> <p>This setting cannot be used when the trigger source is set to [Pulse] of a motor input waveform.</p> <p>Configure the settings by rotating the Y rotary knob.</p> <p>Lit up in green: in 0.1 increments Lit up in red: in 1 increments</p> <p> See "Changing values with rotary knobs" (p.38)</p> <p>You can also drag the trigger level line.</p>

4.2 Changing the Waveform Display and Configuring Recording

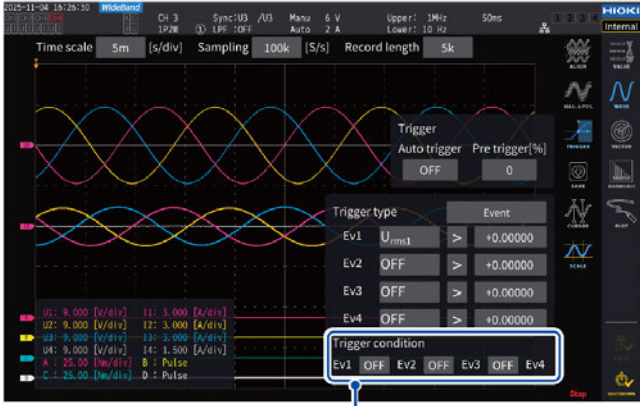
Item	Settings	Description
<p>Ev1 to Ev4 (Events 1 to 4)</p>	<p>Composed of measurement parameters, inequality signs (<, >), and numerical values (0.00000 to ±99999.9T).</p> 	<p>The logical OR and AND of [Ev1] through [Ev4] determine the trigger conditions. The logical AND takes precedence over the logical OR.</p>

4.3 Recording Waveforms

Recording waveforms continuously

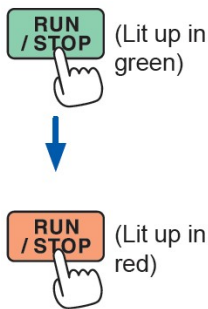

- 1 Press the **RUN/STOP** key.

The instrument enters the trigger standby state.

Recording will start when a trigger is activated.

The instrument will repeatedly wait for a trigger after recording waveforms of the recording length.

- 2 Press the **RUN/STOP** key.

Recording will stop.

- If the **RUN/STOP** key is pressed to stop waveform storage operation, waveforms may not be saved correctly.
- Always press the **SINGLE** key to acquire waveforms to be saved.

Recording a waveform once

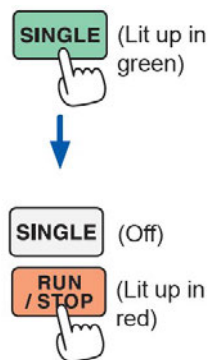

- 1 Press the **SINGLE** key.

The instrument enters the trigger standby state.

Recording will start when a trigger is activated.

Once waveforms of the recording length have been recorded, recording will stop.

Pressing **RUN/STOP** while the instrument is in the standby state will stop recording.

Activating the trigger manually



- 1 Press the **MANUAL** key while the instrument is in the standby state.

Pressing the key can activate a trigger, starting recording waveforms.

4.4 Analyzing Displayed Waveforms

Displaying measured values of waveforms (cursor measurement)

You can use the two cursors to display cursor-measured values for the selected waveform. Cursor-measured values can be displayed for a voltage waveform, a current waveform, and a motor input waveform of each wiring configuration, along with the differences between the two cursors' respective values.

Display screen: **MEAS** key > **[WAVE]** > **[WAVE]**



1 Cursor-value display window

- 1 Tap **[CURSOR]** to display the cursors.
- 2 Use the X and the Y rotary knobs to move the cursors and to display the maximum and minimum cursor-measured values in order.

Moving the X cursor

Rotate the knob to switch the values to be displayed in the following order: Displaying minimum value, moving cursor, displaying maximum value, displaying minimum value display, moving cursor, and displaying maximum value.



Moving the Y cursor

The Y rotary knob moves in the same manner as the X rotary knob. You can also slide the cursor.



The following parameters are displayed on the cursor display window:

- X cursor-measured values (level and time axis), maximum/minimum indication
- Y cursor-measured values (level and time axis), maximum/minimum indication
- Difference (Δ) between X and Y cursor-measured values (level difference and time axis difference)
- Reciprocal of the cursor X and cursor Y time-axis difference ($1/\Delta$)

- For each dot on the displayed waveform, there are two pieces of data (the maximum and minimum values). Consequently, you can switch between the maximum and minimum value display during cursor measurement.
 - 🔍 See “Time axis setting” (p.152)
 - 🔍 See “Peak-to-peak compression” (p.153)

- Cursor measurement can be available on the following waveform-related screens:
 - **[WAVE]** screen (waveform display)
 - **[WAVE+ZOOM]** screen (waveform + zoom display)
 - **[WAVE+VALUE]** screen (waveform + measured value display)

Displaying enlarged views of waveforms (zoom function)

The displayed waveforms can be enlarged along the time axis (horizontal axis).

The waveforms within the section indicated in yellow (zoom section) in the waveform display area are enlarged in the time axis direction to display them in the enlarged waveform display area. Straight lines interpolate between two adjacent points when the magnification is certain or more.

Display screen: **MEAS** key > **[WAVE]** > **[+ZOOM]**

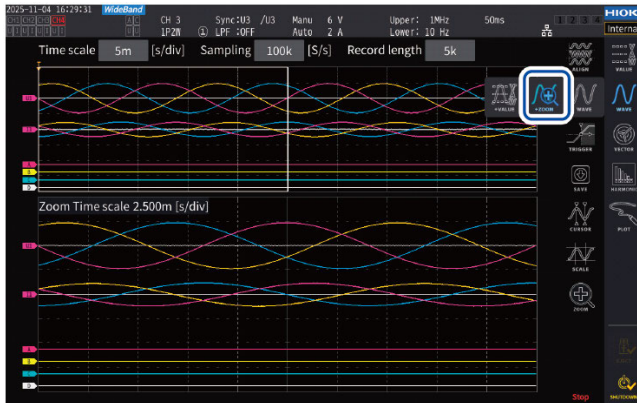

1 Tap the **SINGLE** key to acquire waveforms.
 See “4.1 Waveform Display Method” (p.149)

2 Tap the **[ZOOM]** icon.

3 Use the X rotary knob to select the magnification (the zoom section size).
 The selectable magnifications depend on the number of storage points (**×2** to **×1M**).

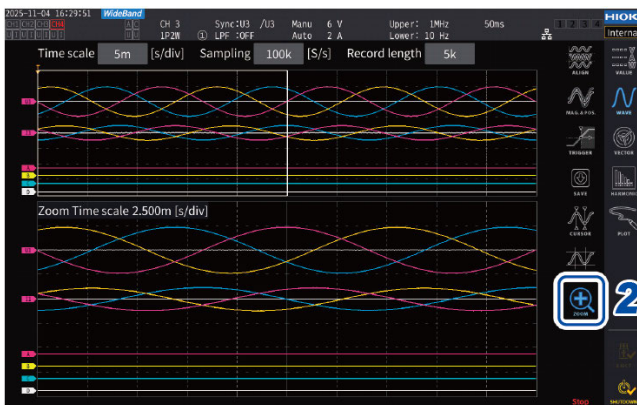

4 Use the Y rotary knob to move the zoom section.
 The zoom section moves horizontally. Pressing the Y rotary knob can switch among the three zoom-section moving speeds. Using the lowest speed mode can update the zoom section in increments of one point of storage data point.

IMPORTANT

- The broken green line represents the zoom section after the change of position and magnification.
- The waveforms in the solid-white-line zoom section are displayed at the bottom of the screen.
- To use the zoom function, acquire waveforms using the SINGLE trigger.
 See “4.3 Recording Waveforms” (p.159)

What do they indicate?



 is displayed	There is no waveform data to display, such as immediately after startup.
[Zoom Time scale] is displayed in red.	The setting is changed while the enlarged waveform display area shows enlarged waveforms, resulting in a discrepancy between the zoom setting and that of the actual waveform display.

4.4 Analyzing Displayed Waveforms

5 Various Functions

5.1 Time Control Function

The time control function can control the auto-save operation and the integration function by specifying time. Two control methods are available: timer control and real time control. Valid settings depend on the integration control method.

🔍 See “Integration measurement while using the time control function” (p.104)

🔍 See “Automatically saving measured data” (p.212)

Timer control

The timer control stops auto-save operation and integration automatically once the timer control time has elapsed.

- If timer control time has been set so that it is longer than the difference between the real-time-control start and stop times, the timer control time will be ignored.
- If you press the **START/STOP** key before the timer control ends, integration will stop, and integrated values will be retained. If the **START/STOP** key is pressed again in this state, integration will resume and will be performed for the duration of the timer setting. (cumulative integration)

Timer setting

This can be set when **[Timer]** is set to ON. Enter the value using the “Numeric keypad window” (p.39).

Valid setting range: 0 h 0 min. 1 s to 9999 h 59 min. 59 s

Real time control

The real time control can start or stop operation at predetermined times.

- If the real-time-control time has been set so that it is longer than the timer time, integration will start at the real-time-control start time and stop at the timer time. (The real-time-control stop time will be ignored.)
- If the set time is the past time as viewed from the present, real-time control cannot be started.
- If the integration is stopped during the real-time-control operation, the real time control is disabled.

Start time and stop time

The start time and stop time can be set when **[Real time control]** is set to ON. Enter the value using the “Numeric keypad window” (p.39).

Use the 4-digit year and 24-hour format. The times can be set in increments of 1 min.

Example: 1:11 pm on January 11, 2025 → **[2025/1/11 13:11:00]**

Time setting range

Lower limit	At 00:00:00 on January 1, 2025*1
Upper limit	At 23:59:59 on December 31, 2099

*1 This is the lower limit when the **[Time zone]** is set to GMT +0:00. Depending on the time zone setting, the lower limit will change by the difference from GMT.

Time control function setting method

When using the all-wiring-configuration integration

Display screen: **SYSTEM** key > **[TIME CONTROL]**

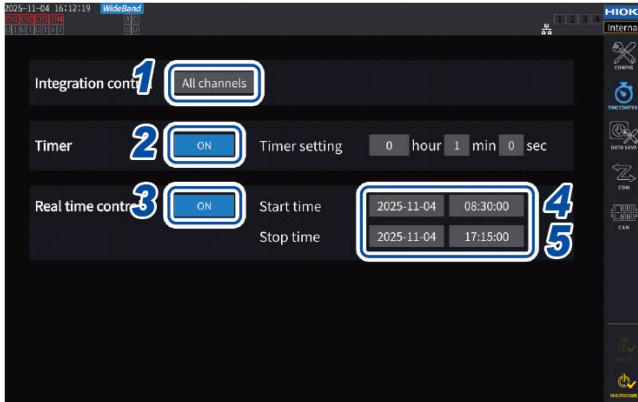

- 1 Tap **[Integration control]** box indicating **[All channels]**.
- 2 (When using the timer control)
Tap the **[Timer]** box to set it to **[ON]**.
- 3 (When using Real time control)
Tap the **[Real time control]** box to set it to **[ON]**.
- 4 Tap the **[Start time]** box to set the integration start time.
- 5 Tap the **[Stop time]** box to set the integration stop time.

When using each-wiring-configuration integration

Display screen: **SYSTEM** key > **[TIME CONTROL]**



- 1 Tap **[Each Wiring]** box under **[Integration control]**.
- 2 (When using the timer control)
Tap the **[Timer]** box of which you wish to control to set it to **[ON]**, and then tap **[Setup]** to enter the timer setting value.
- 3 (When using Real time control)
Tap the **[Real time control]** box of which you wish to control to set it to **[ON]**, and then tap **[Setup]** to enter the start and stop time.
Tap the **[Real time control]** box to set it to **[ON]**.
- 4 Tap the **[Control channel]** box to set the channel to be controlled to **[ON]**.

Before performing integration or saving data using the time control function

- Make sure that you set the clock (current time) before automatically saving data or using the integration function.
🔍 See “6 System Settings” (p.189)

- The auto-save operation and the integration function cannot be configured separately.
- When the integration control setting is set to All Channel, the integration function is always active. After stopping the time control, press the **DATA RESET** key to reset integrated values.
- When the integration control setting is set to Each Wiring, the auto-save operation is not available.

5.2 Average Function

The average function averages measured values and displays results. This function can be used to obtain more stable display values when measured values fluctuate and cause large variations in the display. During average operation, an average indicator appears in the setting indicators area at the top of the screen.

 See "Measurement screen" (p.43)

Average settings

There are two averaging modes: exponential average and moving average. Exponential averaging mode calculates averages of values after multiplying time factors to give different weights, according to the response speed setting. Moving averaging mode creates averages of subsets containing the user-specified number of most recent values.

Display screen: **INPUT** key > **[COMMON]**

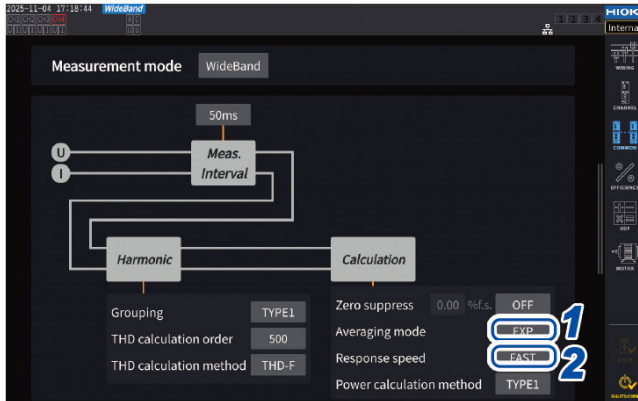

- 1 Tap the **[Averaging mode]** box, then select the averaging mode from the list.

OFF	Averaging not performed
EXP	Exponential average (Set the response speed.)
MOV	Moving average (Set the averaging count.)

When the data update interval setting is changed to 1 ms, the averaging mode is changed to OFF.

If the averaging mode is set to other than OFF when the data update interval is set to 1 ms, the data update interval setting is changed to 10 ms.

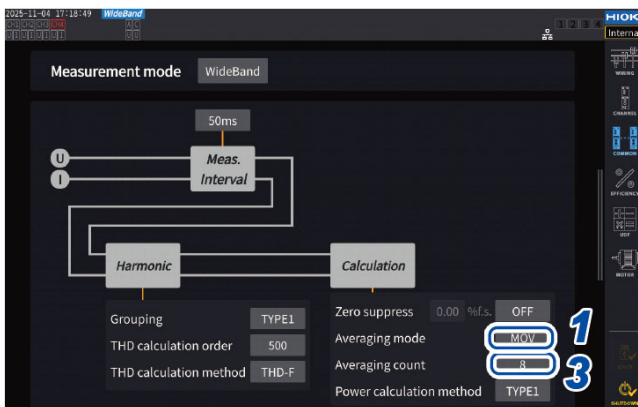

- 2 (If you have selected **[EXP]**)

Tap the **[Response speed]** box, then select the response speed from the list.

FAST, MID, SLOW

It does not affect the display update interval. The response speed varies depending on the data update interval setting.

Data update interval	Response speed		
	FAST	MID	SLOW
10 ms	0.1 s	0.8 s	5 s
50 ms	0.5 s	4 s	25 s
200 ms	2.0 s	16 s	100 s

- 3 (If you have selected **[MOV]**)

Tap the **[Averaging count]** box, then select the averaging count from the list.

2, 4, 8, 16, 32, 64

Average operation

- The average function works for peak and integrated values, and all measured values except harmonic data acquired at data update intervals of 10 ms or less.
- The instrument displays the following values as the peak voltage and peak current values: In exponential averaging mode, the peak values of all data that consists of the most recent points. In moving averaging mode, the peak values of a subset that forms from the user-specified number of the most recent values.
- It applies not only to display values but also to measured values saved on a USB flash drive or in the internal memory, measured values acquired using communications, and measured values output as an analog signal.
- When a measured-value-related setting, such as the wiring mode or range, changes, average calculation is restarted.
- When averaging and auto-ranging are used together, it may take longer than usual to stabilize measured values on the correct value.
- Integrated measured values during average operation are calculated from measured values prior to average operation.
- Internal average calculations continue even when the hold function is freezing on-screen measured values.
- The peak hold function applies to measured values after average operation.

Behavior when an overload condition occurs

If an overload condition occurs during average operation, average calculations will continue using internal calculation values.

IMPORTANT

- Settings cannot be switched on a wiring configuration or channel basis.
- The invalidation period for measured values after the range has been changed varies depending on the settings.
- Waveforms shown on the screen and D/A output waveforms are not affected by the peak hold operation.
- For more information about average calculation methods for different types of measured values, see the average section.
-  See “10.5 Specifications of Equations” (p.375)

5.3 Hold function

By pressing the **HOLD** key, you can stop display updating for all measured values and freeze the on-screen data at the time when the key was pressed. By switching screens in that state, you can view other measured data at the time when the on-screen data was frozen.

In addition, the same operation as the HOLD key can be performed using the **HOLD** external control signal.

🔍 See “8.3 Controlling Integration with External Signals” (p.254)

During hold operation, the **HOLD** key is lit up in red, and the **[HOLD]** icon appears in the screen’s operating status indicator.

🔍 See “1.4 Basic Operation (Screen Display and Layout)” (p.37)

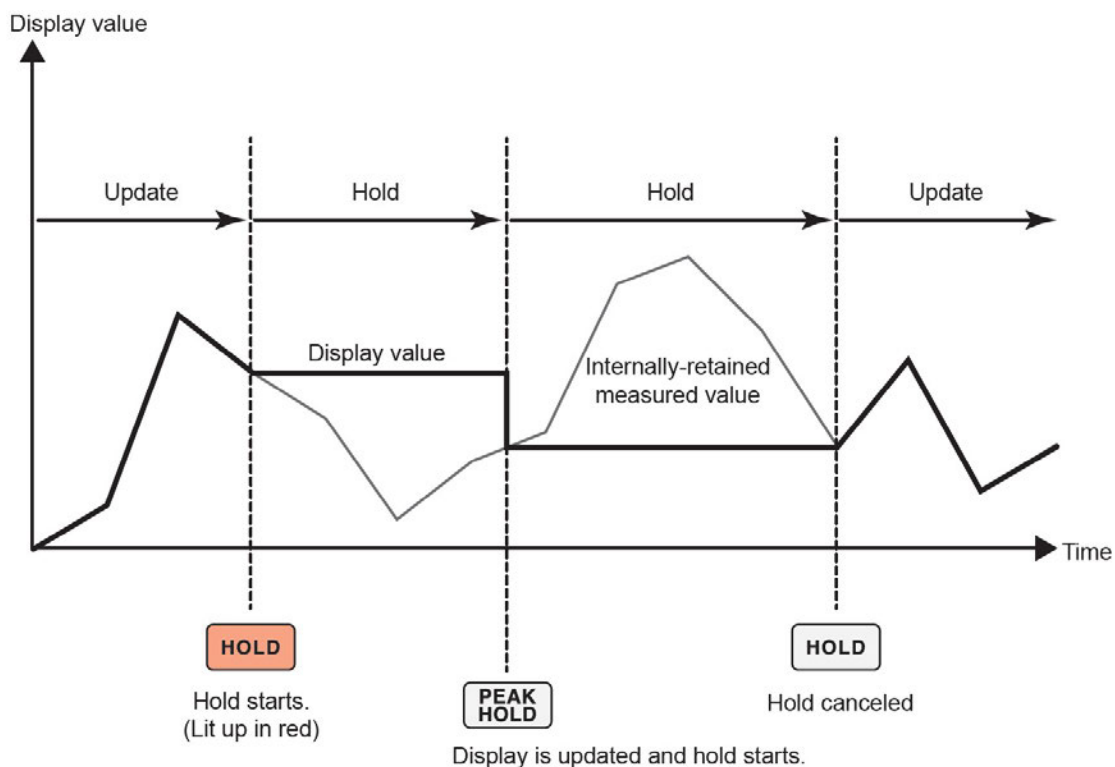

Each time the **PEAK HOLD** key is pressed, measured values at that point in time are displayed. Measurement, calculations, and averaging continue internally.

Canceling the hold state

Press the **HOLD** key again during hold operation to cancel the hold state.

Operation in the hold state

- Hold operation also applies to the following measured values:
 - (1) Measured values to be stored onto the USB flash drive or in the internal memory
 - (2) Measured values to be acquired using communications
 - (3) Measured values to be outputted as an analog signal
- Waveforms, the clock, and the peak-over display are updated.
- When the **PEAK HOLD** key is pressed, data is replaced with the latest internal data.
- The instrument retains the data without updating it even if the interval time set in the time control function has elapsed.
- Average and integration calculations continue to be performed internally.
- Settings that affect measured values such as range and the LPF settings cannot be changed.
- When the range setting is set to **AUTO**, the range is fixed to that at the time when the **HOLD** key was pressed.
- The hold function cannot be used together with the peak hold function.
- Waveforms shown on the screen and D/A output waveforms are not affected by the peak hold operation.
- The data frozen during hold operation is not displayed when the **HOLD** key was pressed, but rather the data is retained internally when the **HOLD** key was pressed among those acquired at data update intervals.

5.4 Peak hold function

Pressing the **PEAK HOLD** key places the instrument in the peak hold state. Only parameters whose values exceed the past peak value are updated. This function is useful to thoroughly capture phenomena characterized by instantaneously large values, for example rush current.

During peak hold operation, the **PEAK HOLD** key is lit up in red, and the **[PEAK HOLD]** icon on the screen's operating status indicator appears.

🔍 See “Common screen display” (p.41)

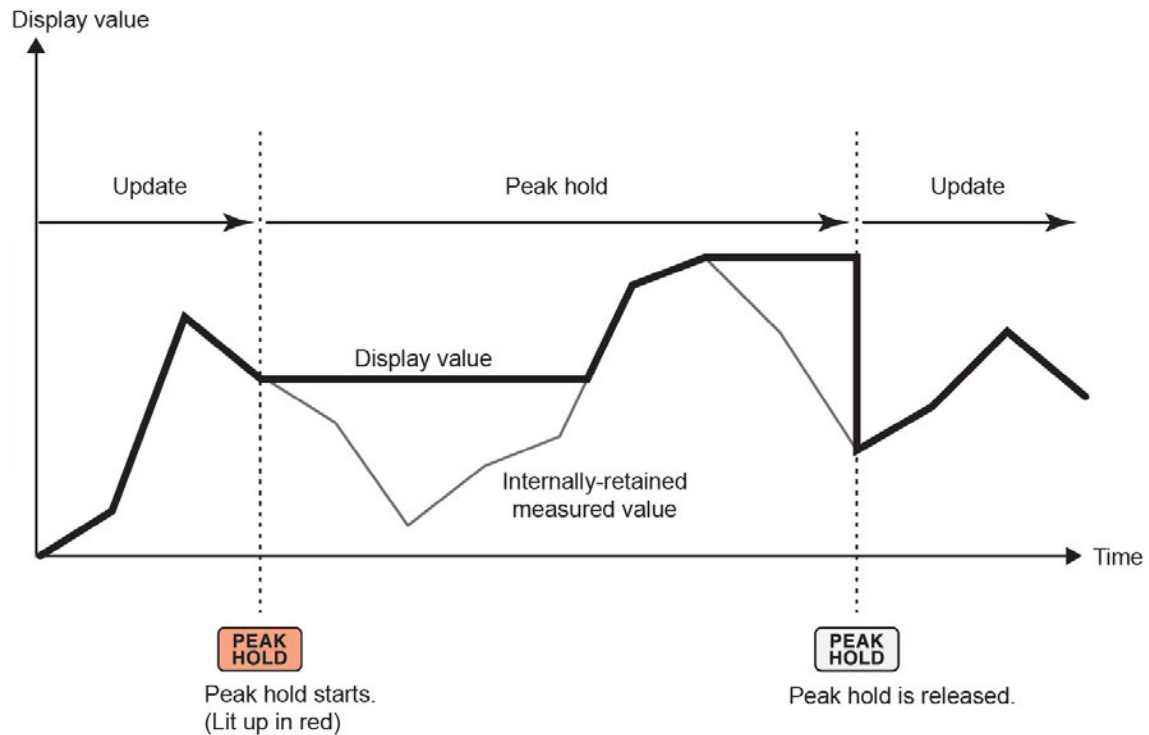

When the past peak value is exceeded, the displayed value for that parameter is updated. Measurement continues internally.

Canceling the peak hold state

Press the **PEAK HOLD** key again during the peak hold operation to cancel the peak hold state.

Operation in the peak hold state

- Peak hold operation also applies to the following measured values:
 - (1) Measured values to be stored onto the USB flash drive or in the internal memory
 - (2) Measured values to be acquired using communications
 - (3) Measured values to be outputted as an analog signal
- Waveforms, the clock, and the peak-over display are updated.
- When the display is overloaded, it will show [-----]. In this case, cancel the peak hold operation, then switch the present range over to a range in which the overload condition will not occur.
- The maximum value is determined using the absolute value of measured values. (However, this method does not affect voltage or current peak values.)

For example, if a power of -60 W is inputted after that of 50 W was inputted, the display will indicate [-60 W] because the absolute value of -60 W is greater than that of 50 W.
- When the **HOLD** key is pressed, the peak hold value is reset, and another peak hold operation starts from that point.
- The instrument retains the peak-hold value without updating it even if the interval time set in the time control function has elapsed.
- During average calculation, peak hold operation applies to measured values after averaging.
- Settings that affect measured values such as range and the LPF settings cannot be changed.
- When the range setting is set to **[AUTO]**, the range is fixed to that at the time when the **PEAK HOLD** key was pressed.
- The hold function cannot be used together with the peak hold function.
- Waveforms shown on the screen and D/A output waveforms are not affected by the peak hold operation.
- The time when the maximum value occurred is not displayed.
- The peak hold function does not affect to integrated values.

5.5 Delta Conversion Function

The delta conversion function measures a three-phase line after converting a delta connection into a Y connection (star connection) or vice versa. The conversion is performed using voltage waveform data sampled at a frequency of 2.5 MHz between different channels based on the formula.

Δ -Y conversion

This function can be enabled when the wiring mode is set to 3P3W3M or 3V3A.

This function can measure phase voltages across internally-Y-connected motor coils even if the motor is used as a delta-connected load, whose neutral point cannot be connected to the instrument.

The voltage waveforms, various measured voltage values, and harmonic voltages are all inputted as line voltages; however, they are calculated as phase voltages.

In 3P3W3M wiring mode

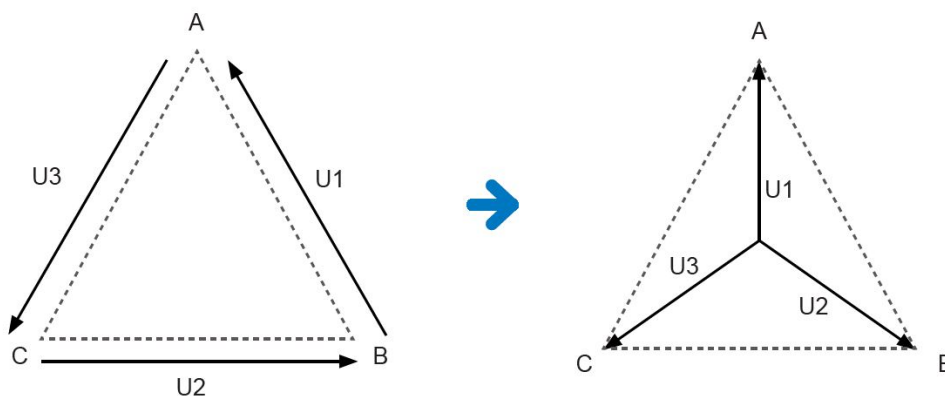

In 3V3A wiring mode

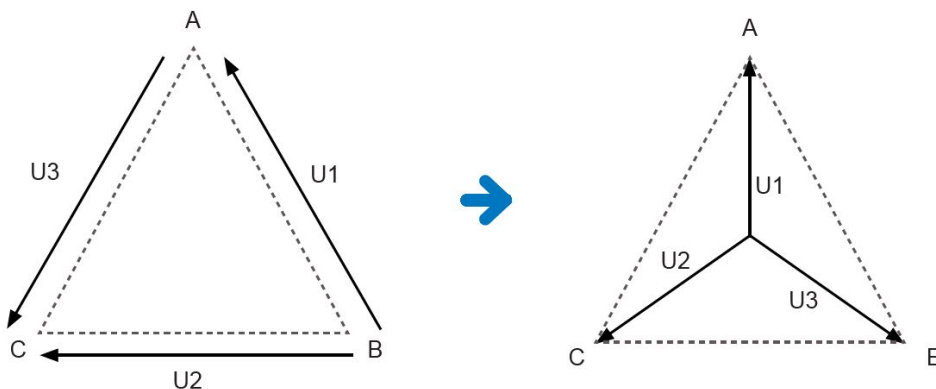

- In Δ -Y conversion, voltage waveforms are converted into vectors and analyzed using a virtual neutral point.
- The result may differ from the actual phase voltages.
- The vector diagram shown on the wiring screen is the same as the 3P4W vector diagram. In 3V3A wiring mode, only the phase sequence will be reversed.
- The two-wattmeter method is used to calculate active power in 3V3A wiring mode, but the three-wattmeter method is used after conversion.
- Peak-over judgment uses not-converted values.

5.5 Delta Conversion Function

- When the voltage range is set to the auto-ranging, voltage range switching is determined by multiplying the range by $1/\sqrt{3}$ (multiplying by approximately 0.57735).

Y-Δ conversion

This function can be enabled in 3P4W wiring mode.

This can measure line voltages when phase voltages are inputted from a Y-connected circuit.

The voltage waveforms, various measured voltage values, and harmonic voltages are all inputted as phase voltages; however, they are calculated as line voltages.

Conceptual diagram of Y-Δ conversion

In 3P4W wiring mode

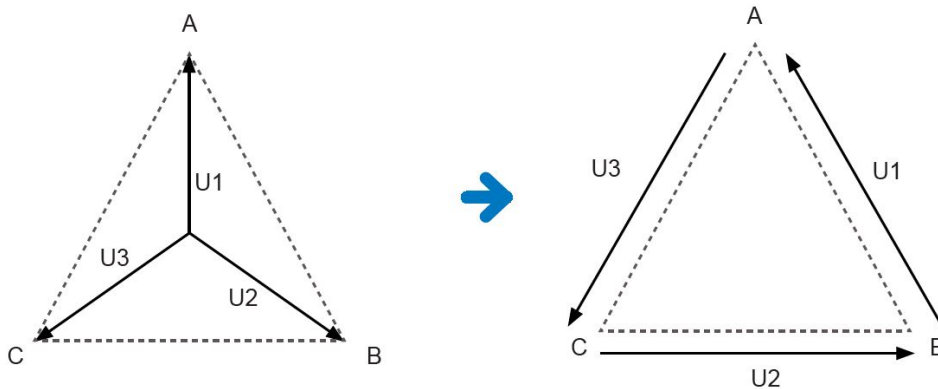

- The vector diagram shown on the wiring screen is the same as the 3P3W3M vector diagram.
- Peak-over judgment and the voltage peak value display range are determined using not-converted values.
- When the voltage range is set to auto-ranging, voltage range switching is determined using converted measured values.

Display screen: **INPUT** key > **[CHANNEL]**



- 1 Tap the channel detail display area for the channel you wish to configure to open the settings window.

5.5 Delta Conversion Function

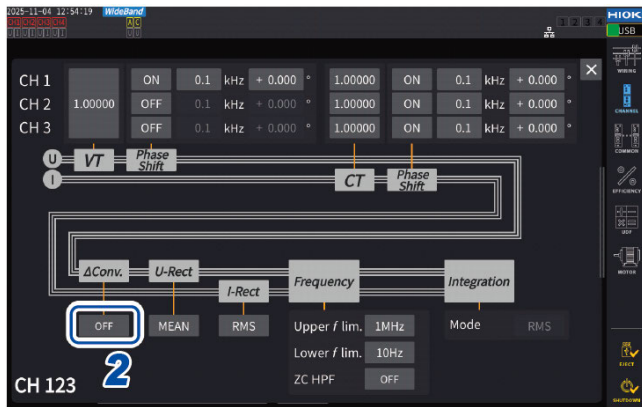

- 2 Tap the [Δ Conv.] box to set Y- Δ conversion to [ON].

5.6 Power calculation method

This function enables you to select equations of reactive power, power factors, and power phase angles to follow those of legacy Hioki instruments.

Since no standardized equations for apparent power and reactive power have been defined for distorted three-phase AC signals, different instruments use different equations. To improve its compatibility with previous models, the instrument allows you to choose from among three equation settings.

See “10.5 Specifications of Equations” (p.375)

Display screen: **INPUT** key > **[COMMON]**

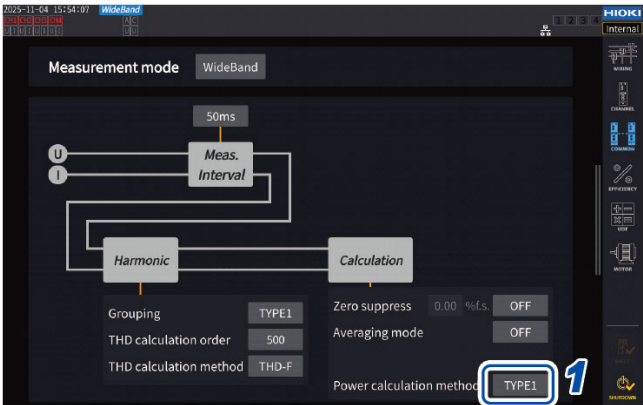

1 Tap the **[Power calculation method]** box, then select the calculation type from the list.

IMPORTANT
Type 1, Type 2, and Type 3 are compatible with each equation types used in the Hioki PW6001 and PW8001 Power Analyzers.

Equation types

Type 1	When any mode other than 3V3A is selected	Provides compatibility with the Type 1 setting used by Hioki PW3390, 3390, and 3193.
	When 3V3A is selected	Provides compatibility with the Type 2 setting used by Hioki 3192 and 3193.
Type 2	Provides compatibility with the Type 2 setting used by Hioki 3192 and 3193.	
Type 3	Uses signs of active power as those of power factors.	

If you do not use any model listed above or cannot decide a type to be used, select **[TYPE1]**. The different formulas do not yield different results for active power (even when waveforms are distorted) since active power is calculated directly from values sampled from voltage and current waveforms.

5.7 User-defined formula (UDF)

Setting the user-defined formulas (UDF)

You can define computing equations by combining the instrument's measured values, numerical values, and functions.

The set calculated values can be displayed on the measurement screen or calculated using the set calculated values.

When the data update interval is set to 1 ms, [-----] is always displayed as calculated values. When using user-defined formulas, set the data update interval to a value other than 1 ms.

Display screen: **INPUT** key > **[UDF]**

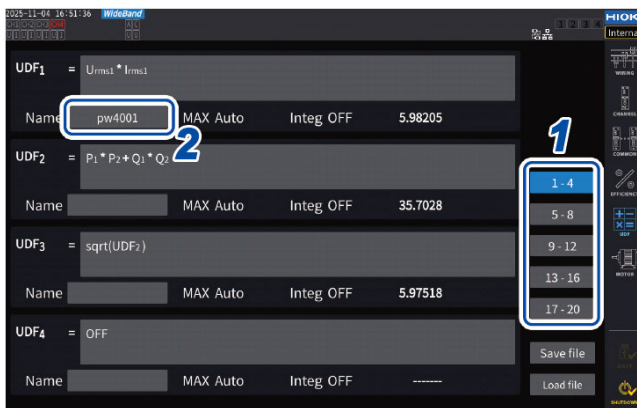

1 Tap a UDF you wish to set.

1-4, 5-8, 9-12, 13-16, 17-20

2 Tap the **[Name]** box and then enter a UDF name using a keyboard. The names you entered here will also be reflected UDFs displayed on the measurement screen.

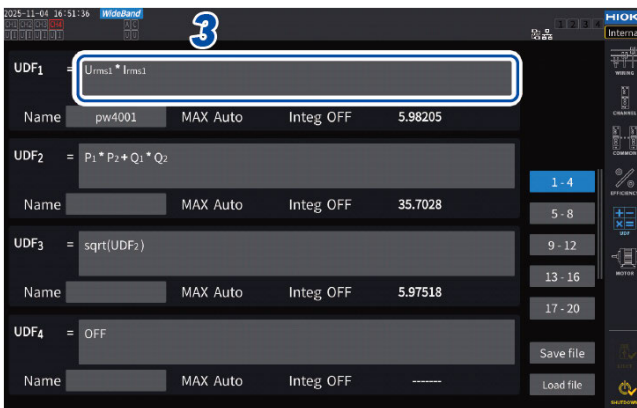

3 Tap the **[UDFn]** box. The setting window will be displayed.

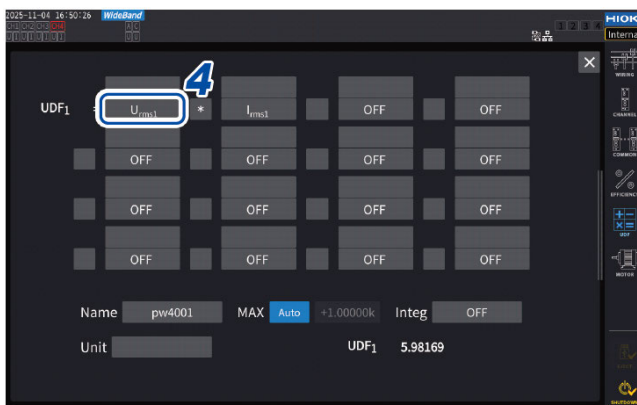

4 Tap a parameter name to select it. The setting window will be displayed.

5.7 User-defined formula (UDF)

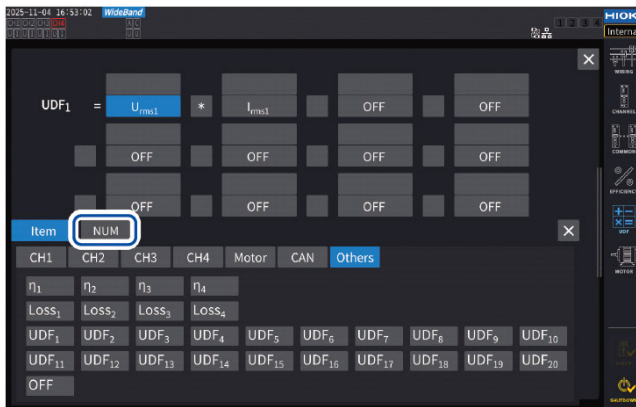

You can select the basic measurement parameters on the parameter selection window. (Other UDF calculation results can also be selected as parameters.)

To delete a selected parameter, select **[OFF]** in **[Others]**.

You can also use the numeric keypad, which can be displayed by tapping **[NUM]**, to enter values.

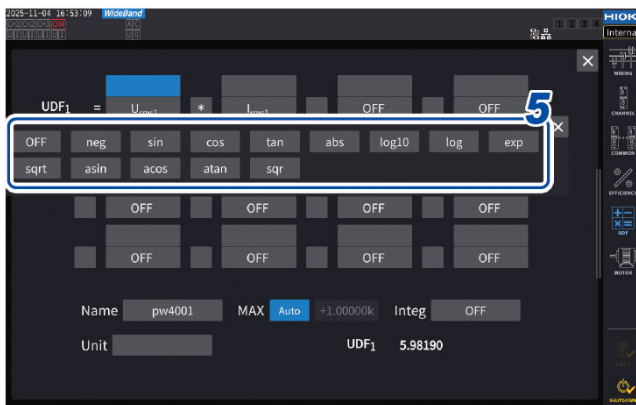

5 Configure the functions.

Option	Function	Effective range
neg	Negative (minus)	–
sin	Sine*	–
cos	Cosine*	–
tan	Tangent*	–
abs	Absolute value	–
log10	Common logarithm	item > 0
log	Logarithm	item > 0
exp	Exponential function	–
sqrt	Square root	item > 0
asin	Arcsine*	-1 <= item <= 1
acos	Arccosine*	-1 <= item <= 1
atan	Arctangent*	–
sqr	Square	–

* Angles are not expressed in radians, but in degrees (°).

Item values outside the valid input range are treated as error values.

5.7 User-defined formula (UDF)



- 6 Select one of the four arithmetic operations.

+ , - , * , /

- The computing order of the four arithmetic operations in equations follows the four-arithmetic-operation rule.
- If you wish to calculate an equation including parentheses, divide it into two.

Calculation example: To calculate (P1 + P2) / P123

UDF1 = P1 + P2

UDF2 = UDF1 / P123

IMPORTANT

If any parameter in the equation satisfies the following conditions, all subsequent equations are not reflected in the UDF.

- Calculation parameter is set to **[OFF]**.
- No parameters of the four arithmetic operations are selected.

Example

Let Urms1 = 1.00000, Urms2 = 2.00000 V, and Urms3 = 3.00000 V. The following equation yields 1.00000.

UDF1 = Urms1 + OFF + Urms3

Alternatively, the following equation yields 3.00000.

UDF1 = Urms1 + Urms2 _ Urms3 * 2

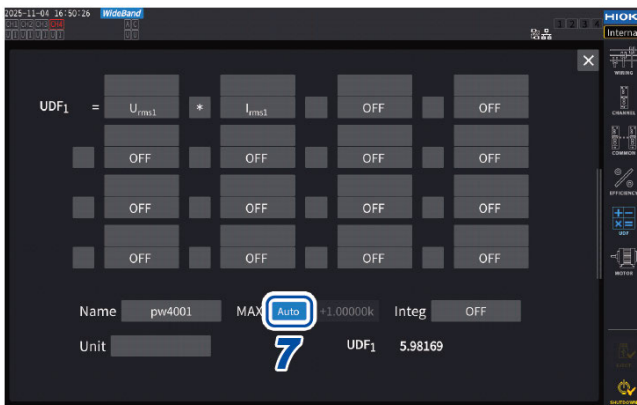

- 7 Tap the **[MAX]** box to select the maximum UDF value.

Auto	The maximum value is automatically set based on the value of the calculation result.
Fixed	Enter the value using the numeric keypad window.
	When [+1.00000] is set UDF display digits: X.XXXXX Effective measurement range: 0.00000 to ±1.00000
	When [+10000.0] is set UDF display digits: XX.XXXX k Effective measurement range: 0.0000 k to ±10.0000 k

When selecting **[UDF]** for the D/A output parameter, set the maximum UDF value to **[Fixed]**. When **[Auto]** is set, the full-scale value is always output.

The value calculated from the display values may differ from the UDF value due to rounding errors.

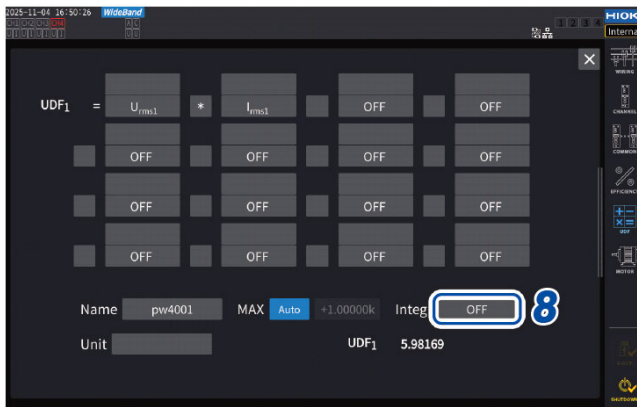

8 Tap the **[Integ]** box to select the integration setting.

Off	No integration is performed
Positive	Only positive values are integrated
Negative	Only negative values are integrated
Total	Both positive and negative values are integrated

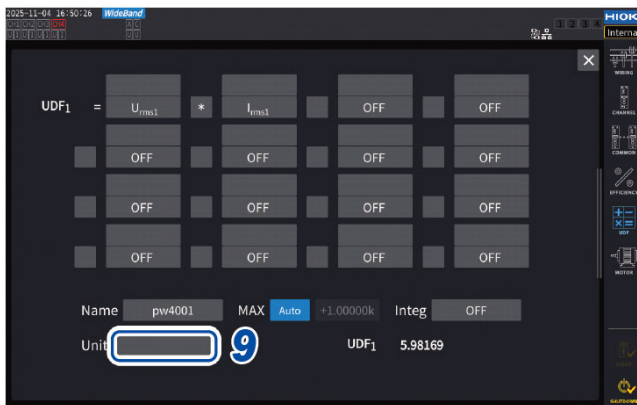

9 Tap the **[Unit]** box and enter the unit on the keyboard. The unit entered here will also be applied to the UDF displayed on the measurement screen.

Saving user-defined formula (UDF) setting data

The instrument's UDF configuration information is saved as a UDF configuration file.

Save destination	USB flash drive, internal memory, FTP server
Filename	Set as desired (up to 8 characters), with JSON extension. Example: PW4001.JSON

Display screen: **INPUT** key > **[UDF]**

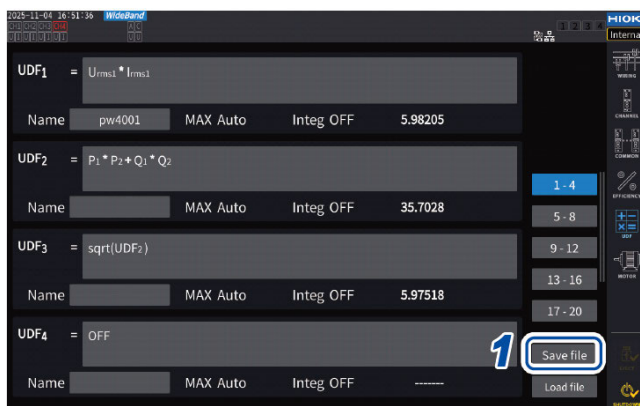

1 Tap **[Save file]**.
The keyboard window will be displayed.

2 Enter a filename.
File names cannot be saved while auto-saving is in progress.

Loading user-defined formula (UDF) setting data

Loading saved UDF settings files can restore the UDF settings.

Display screen: **INPUT** key > **[UDF]**

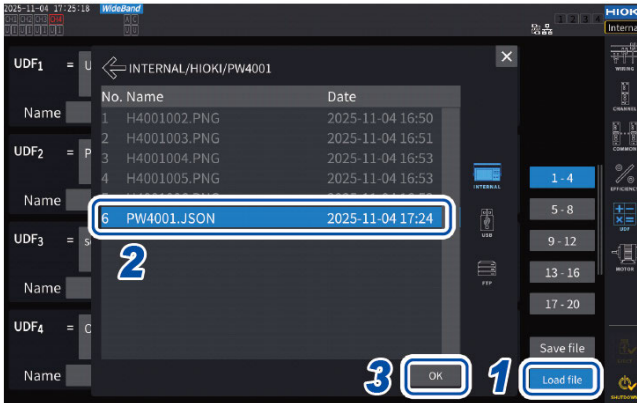

- 1 Tap **[Load file]**.
The UDF settings file loading window will be displayed.
- 2 Tap the folder in which UDF settings files are saved.
- 3 Select a UDF settings file and then tap **[OK]**.

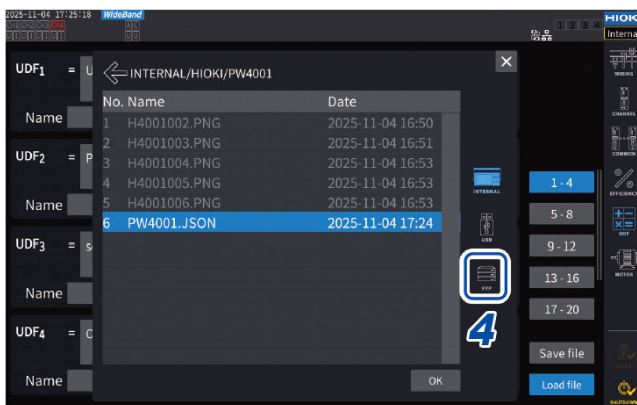

When loading a UDF settings file from the FTP server

- 4 Tap **[FTP]**.
The FTP server file window will be displayed.



- 5 Tap the folder in which UDF settings files are saved.
- 6 Select a UDF settings file and then tap **[OK]**.
Settings cannot be loaded while auto-saving is in progress.

5.8 Graph Display Function

Trend graph

Displays a graph of selected measured values (for up to eight items) as a time series on the **[TREND]** screen.

Display screen: **MEAS** key > **[PLOT]** > **[TREND]**

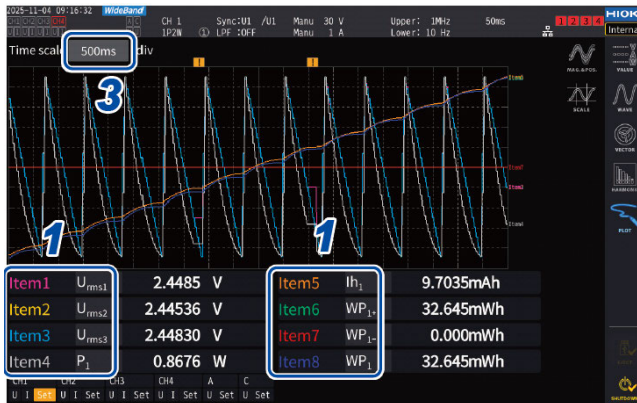

- 1 Tap an item displayed in the graph (**[Item1]** to **[Item8]**).
The settings window for the displayed item will appear.
- 2 Select the item you want to display.
Measured values for selected basic measurement parameters will be shown in measured values display area.
- 3 Tap the **[Time scale]** box and then select the time scale using the X rotary knob.

50 ms/div, 100 ms/div, 250 ms/div, 500 ms/div, 1 s/div, 2.5 s/div, 5 s/div, 10 s/div, 20 s/div, 30 s/div, 1 min/div, 2 min/div, 5 min/div, 10 min/div, 20 min/div, 30 min/div, 1 h/div, 2 h/div, 5 h/div, 10 h/div, 12 h/div, 1 day/div

- 4 Start or stop graph plotting.
Use the **START/STOP** key to start or stop graph plotting.
Starting and stopping work in conjunction with integration and auto-save operations.
Plotted data will be cleared if the **DATA RESET** key is pressed while plotting is stopped (when the **START/STOP** key is lit up in red).
Measurement parameters cannot be changed during plotting.

- Plotted data in the trend graph cannot be saved.
- To confirm the details of measured values, use the auto-save function.
- If the **[Time scale]** is changed during plotting, the graph will be cleared and plotting will start over.
- If the time scale is shorter than the update interval for measured values, display the graph using peak-to-peak compression.
- No graph plotting will take place when each wiring integration is enabled.

Events that occur during measurement

The following indications will be displayed on the screen if the input exceeds the measurement range during measurement, if the measurement range is changed, or if load reduction processing is performed due to high software load.

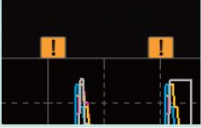
	<p>!</p>	<p>When an event occurs, this mark will be displayed at the top of the graph plot area.</p> <p>Displayed in yellow: Whenever overload, peak-over or if the measurement range is changed (During auto-save operation, measured data will be saved properly, but inputs at the corresponding times will be saved as invalid values.)</p> <p>Displayed in red: Whenever graph plot data is missing due to high load conditions (During auto-save operation, measured data will be saved without being lost.)</p>
---	----------	---

Input module display

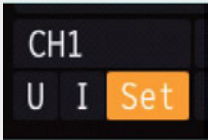
	<p>U</p>	<p>Voltage input for the relevant channel Yellow: An overload condition occurs. Red: A peak exceeds the threshold. The peak-over display take priority.</p>
	<p>I</p>	<p>Current input for the relevant channel Yellow: An overload condition occurs. Red: A peak exceeds the threshold. The peak-over display take priority.</p>
	<p>Set</p>	<p>Yellow: The measurement range of the relevant channel was changed.</p>

Motor analysis option display

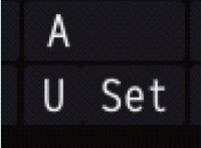
	<p>U</p>	<p>Yellow: A voltage input overload condition occurs on the relevant channel.</p>
	<p>Set</p>	<p>Yellow: The measurement range of the relevant channel was changed.</p>

5.8 Graph Display Function

Value scale display

A list of value scales for the plotted data of selected parameters with Visible set to ON will be shown.

Display screen: **MEAS** key > **[PLOT]** > **[TREND]**

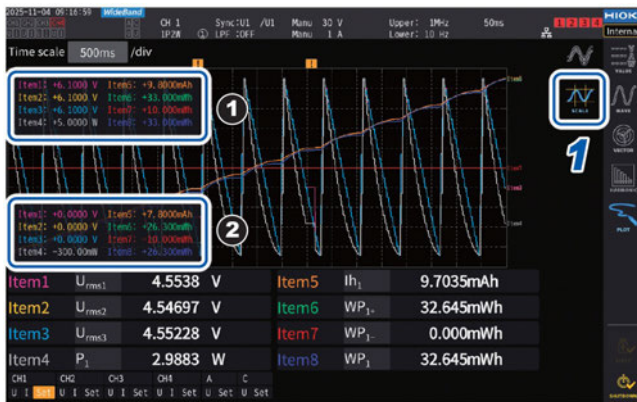

1 Tap **[SCALE]**.

The upper limit and lower limit windows open.

1 Upper limit

2 Lower limit

6 System Settings

6.1 Checking and Changing Settings

This section describes how to check the firmware version number and change settings, such as the display language and beep tone.

Display screen: **SYSTEM** key > **[CONFIG]**



The MAC address can be verified on the **SYSTEM** key > **[COM]** screen.

(1) Language

Japanese, English, Simplified Chinese, Traditional Chinese

(2) Time zone

GMT+14:00 to GMT-12:00

(3) Text format

CSV	Measured data is saved comma-separated (,) format; the decimal point is represented by a period (.).
SSV	Measured data is saved semicolon-separated (;) format; the decimal point is represented by a comma (,).

(4) HIOKI logo

ON	Displays the HIOKI logo at the top-right of the screen.
OFF	The HIOKI logo is not displayed.

(5) Beep tone

ON	Beeps when a key is pressed and an on-screen button is tapped.
OFF	Does not beep even if a key is pressed or an on-screen button is tapped.

(6) Startup screen selection

WIRING	Displays the wiring screen.
LAST	Displays the screen that was being shown when the instrument was last turned off.

(7) Details

Model	Model number of the instrument
Serial number	Serial number: Check Hioki's website for the latest information.
Version number	Firmware version number
Unit	Model numbers of input modules connected to the rear panel of the instrument
Serial number	Serial numbers of input modules
Sensor	Current sensors connected to each input module
Rate	Output rates of current sensors connected to each input module
Serial number	Serial numbers of current sensors connected to each input module
Optional features	Model numbers of available optional features

(8) Time/date settings

2025-01-01 00:00:00 to 2099-12-31 23:59:59

Set the date and time in yyyy-MM-dd hh:mm:ss format for the instrument's internal clock. This clock affects the real time control and properties of files.

Verify that the date and time have been set accurately before using the instrument.

 See "Numeric keypad window" (p.39)

(9) Date format

yyyy MM dd	Year (four digits), month, and date
MM dd yyyy	Month, date, and year (four digits)
dd MM yyyy	Date, month, and year (four digits)

(10) Delimiter

-	Hyphen
/	Slash
.	Period

Tips Time zone

Set the time zone for the area where you use the instrument.
 GMT stands for Greenwich Mean Time.

Country (capital)	Time difference from GMT (daylight saving time)
New Zealand (Wellington)	GMT +12:00 (+13:00)
Australia (Canberra)	GMT +10:00 (+11:00)
Japan (Tokyo)	GMT +9:00
South Korea (Seoul)	GMT +9:00
China (Beijing)	GMT +8:00
Taiwan (Taipei)	GMT +8:00
Singapore (Singapore)	GMT +8:00
Mongolia (Ulaanbaatar)	GMT +8:00
Indonesia (Jakarta)	GMT +7:00
Thailand (Bangkok)	GMT +7:00
India (New Delhi)	GMT +5:30
Pakistan (Islamabad)	GMT +5:00
United Arab Emirates (Abu Dhabi)	GMT +4:00
Oman (Muscat)	GMT +4:00
Iran (Tehran)	GMT +3:30
Romania (Bucharest)	GMT +2:00 (+3:00)
Finland (Helsinki)	GMT +2:00 (+3:00)
Qatar (Doha)	GMT +3:00
Turkey (Ankara)	GMT +3:00
Russia (Moscow)	GMT +3:00
Ukraine (Kyiv)	GMT +2:00 (+3:00)
Greece (Athens)	GMT +2:00 (+3:00)
Germany (Berlin)	GMT +1:00 (+2:00)
France (Paris)	GMT +1:00 (+2:00)
Netherlands (Amsterdam)	GMT +1:00 (+2:00)
Italy (Rome)	GMT +1:00 (+2:00)
Poland (Warsaw)	GMT +1:00 (+2:00)
Switzerland (Bern)	GMT +1:00 (+2:00)
Czech (Prague)	GMT +1:00 (+2:00)
Belgium (Brussels)	GMT +1:00 (+2:00)

6.1 Checking and Changing Settings

Tips

Country (capital)	Time difference from GMT (daylight saving time)
Sweden (Stockholm)	GMT +1:00 (+2:00)
Denmark (Copenhagen)	GMT +1:00 (+2:00)
Norway (Oslo)	GMT +1:00 (+2:00)
Spain (Madrid)	GMT +1:00 (+2:00)
Hungary (Budapest)	GMT +1:00 (+2:00)
Austria (Vienna)	GMT +1:00 (+2:00)
Slovenia (Ljubljana)	GMT +1:00 (+2:00)
Egypt (Cairo)	GMT +2:00 (+3:00)
South Africa (Pretoria)	GMT +2:00
United Kingdom (London)	GMT +0:00 (+1:00)
Portugal (Lisbon)	GMT +0:00 (+1:00)
USA (Washington DC)	GMT -5:00 (-4:00)

As of March 2025

6.2 Initializing the Instrument

If the instrument is operating in a strange manner, check it as described in “11.2 Troubleshooting” (p.395). If you are unsure of the cause, perform the system reset or boot key reset.

System reset

This section describes how to initialize all settings other than the language setting and communications settings to their default settings.

🔍 See “6.3 Factory Default Settings” (p.195)

Display screen: **SYSTEM** key > **[CONFIG]**

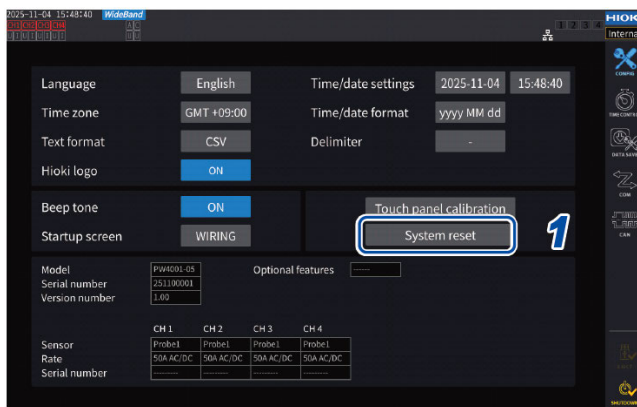

- 1 Tap **[System reset]**.
A confirmation dialog box is displayed.
- 2 Tap **[Yes]** to reset the system.

Boot-key reset

This section describes how to initialize all settings including the language setting and communications settings to their default settings.

All measurement and image data stored in the internal memory will be erased.

You can initiate the boot key reset by pressing the **SYSTEM** key while the operating system is starting up immediately after the instrument is turned on.

Touch panel calibration

Display screen: **SYSTEM** key > [CONFIG]

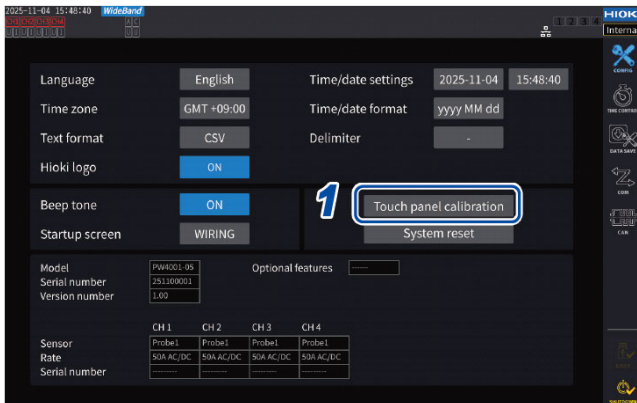

1 Tap [Touch panel calibration].

A confirmation dialog box is displayed.

2 Tap [Yes].

The instrument will reboot and the Touch Panel Calibration screen will be displayed. A total of five [+] signs will be displayed clockwise from the top left. Tap the center of each one.

Tips

- The touch panel can be calibrated by pressing and holding the SCREEN SHOT key when the OS starts up immediately after turning on the power.
- Touch panel calibration results will not be initialized by a system reset or boot key reset.

6.3 Factory Default Settings

The following tables list the instrument's factory default settings.

The measurement screen and recorded data settings will also be reset.

Parameter	Default setting
Wiring	1P2W
Synchronization source	U1, U2, U3, U4
U range	1500 V
U auto-ranging	OFF
U rectifier	RMS
VT ratio	1.0 (off)
Voltage probe phase compensation	OFF
I range	Sensor's rated current
I auto-ranging	OFF
I rectifier	RMS
CT ratio	1.0 (off)
LPF	OFF
Sensor phase compensation	OFF*1
Integration mode	RMS
Upper frequency limit	1 MHz
Lower frequency limit	10 Hz
ZC HPF	OFF
Delta conversion	OFF
Data update interval	50 ms
Measurement mode	Wideband
Grouping	Type 1
THD calculation order	500th
THD calculation method	THD-F
Averaging mode	OFF
Zero suppress	OFF
Power calculation method	Type 1
Efficiency calculation mode	Fixed
UDF setting	Calculation item: OFF Function: <input type="checkbox"/> Four arithmetic operations: <input type="checkbox"/> UDF name: <input type="checkbox"/> Max. value: +1.00000 k (Auto) Integration: OFF Unit: <input type="checkbox"/>

6.3 Factory Default Settings

Parameter	Default setting
Efficiency calculation Pin, Pout	P1
Display language*2	English
Beep tone	ON
Startup screen selection	Wiring (Wiring screen)
(Motor) synchronization source	DC
Motor analysis option Wiring configuration	Torque, Speed
Torque input	Analog
(Motor) LPF	OFF
Motor voltage range	5 V
RPM input	Pulse
Torque scaling	1.0
Pulse count	2
Number of motor poles	4
Slip input frequency	fU1
Phase zero adjustment	0.000
Output range	1 V f.s.
Integration full scale	1
Output parameters	D/A1 to D/A8: WAVE U1, I1U2, I2, U3, I3..., U4, I4 D/A9 to D/A16: Trend Urms1
Integration control	All channels
Timer	OFF
Timer setup	1 min.
Real time control	OFF
Priority save destination	USB
Auto-save	OFF
Data save interval	1 s
Manual save	OFF
Screenshot	OFF
Comment entry	OFF
Simultaneous saving of settings	OFF
DHCP*2	OFF
IP address*2	192.168.1.1
Subnet mask*2	255.255.255.0
Default gateway*2	0.0.0.0
BNC synchronization	OFF

Parameter	Default setting
USB communication mode*2	Command
CAN settings	CAN mode: CAN Communication speed: 500 kbps Sampling point: 80% Communication rate: OFF
Time zone*2	GMT +09:00
Text format*2	CSV
Date format*2	yyyyMMdd
Delimiter*2	-
HIOKI logo	ON

*1 Automatically set to AUTO when a current sensor with the automatic recognition function is connected.

*2 Parameter is not initialized by the system reset, but by the boot key reset. See "Boot-key reset" (p.193).

6.3 Factory Default Settings

7

Saving Data and Managing Files

The following keys are used to save data onto and load it from a USB flash drive or the internal memory.

SAVE	Saves measured data manually.
START / STOP	Saves measured data automatically.
On the touchscreen [Save]	Saves waveform data.
SCREEN SHOT	Saves a screenshot.
FILE	Browse folders for media. (The following operations are possible on the [FILE] touchscreen.) <ul style="list-style-type: none">• Saves settings data and a settings file.• Loads settings data and a settings file.• Saves data from the internal memory on a USB flash drive.

IMPORTANT

Saving simultaneously to a USB flash drive and the internal memory is not possible.

7.1 Internal memory

You can save data in the instrument's internal memory. You can also copy data from the internal memory to a USB flash drive.

CAUTION



■ **Do not turn off the power while accessing the internal memory.**

Doing so could damage the internal memory.
The indicator border lights up yellow while saving to media.



■ **Back up important data and store the backup securely.**

The internal memory, which uses flash memory, has a service life. It could lose the ability to store and load data after extended use.

In this situation, the instrument is in need of repair. Please contact your authorized Hioki retailer or reseller. Hioki is not liable for data recorded in the internal memory, regardless of the nature or cause of the accident or damage involved.

Copying to a USB flash drive

Display screen: **FILE** key > **[INTERNAL]**

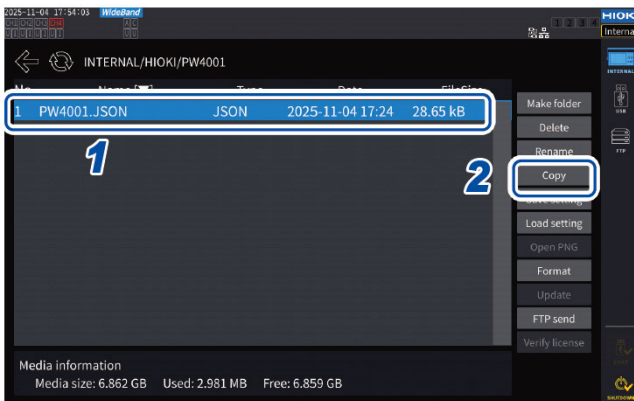

- 1 Select the file to be copied.
- 2 Tap **[Copy]**.

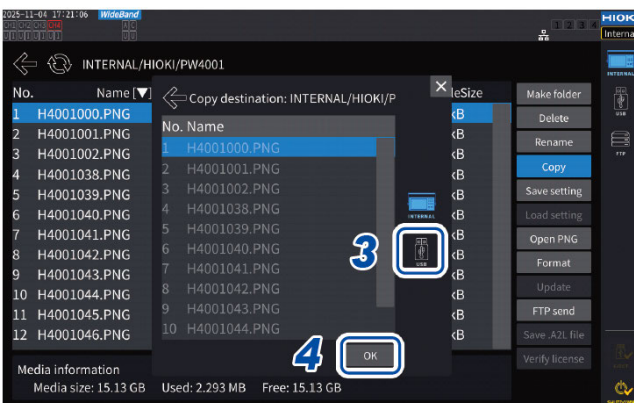

- 3 Select **[USB]** in the dialog box that opens.
- 4 Select the folder in which you wish to save the file and tap **[OK]**.

7.2 USB flash drive

Data can be saved on a USB flash drive. Use only mass storage class USB flash drives. Data is saved in the [\[HIOKI/PW4001\]](#) folder. All files created by the instrument will be stored in this folder. Sub-folders can also be created in this folder.

CAUTION



- **While accessing the USB flash drive, do not remove it or turn off the power to the instrument.**

Doing so could damage the USB flash drive.



- **Before handling the USB flash drive, discharge static electricity from your body.**

- **Turn on the instrument before inserting the USB flash drive.**

Application of static electricity could damage the USB flash drive or cause the instrument to malfunction. Additionally, the instrument could fail to turn on.

- **Back up important data and store the backup securely.**

USB flash drives, which use flash memory, have a service life. They could lose the ability to store and load data after extended use. If you encounter this issue, purchase a new drive.

Hioki is not liable for data stored on USB flash drives, regardless of the nature or cause of the accident or damage involved.

IMPORTANT

If you want to automatically save measurement data, it is recommended to use the internal memory.

USB flash drive requirements for this instrument

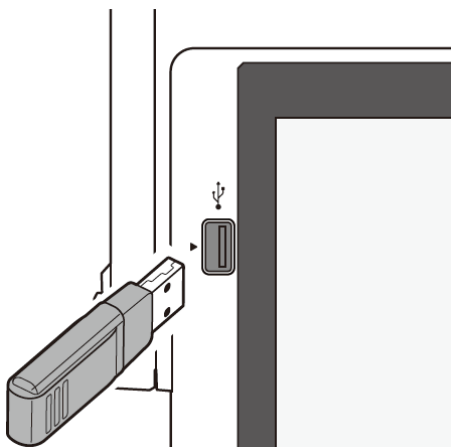

Connector	USB Type A connector
Electrical specifications	USB3.0
Current that can be supplied	Up to 500 mA
Number of ports	1
Supported USB flash drives	USB Mass Storage Class compatible
File system	FAT16, FAT32

If the instrument cannot recognize a USB flash drive, press the reload button  on the [\[FILE\]](#) screen. If the instrument does not recognize a USB flash drive, try to use a different one. The instrument does not support all USB flash drives available on the market.

Formatting the USB flash drive

🔍 See “Formatting a USB flash drive or the internal memory” (p.227)

Removing the USB flash drive

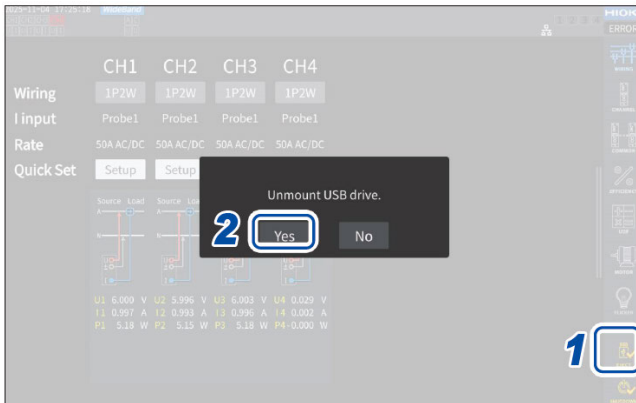

- 1 Tap **[EJECT]**.
- 2 When the confirmation dialog box appears, tap **[Yes]**.
- 3 Remove the USB flash drive from the instrument.

IMPORTANT

Failure to follow the correct procedure for removing the USB flash drive could damage the data on the USB flash drive.

7.3 Data Save Destination

Use **[Priority save destination]** to select whether to save on a USB flash drive or in the internal memory.

Display screen: **SYSTEM** key > **[DATA SAVE]**

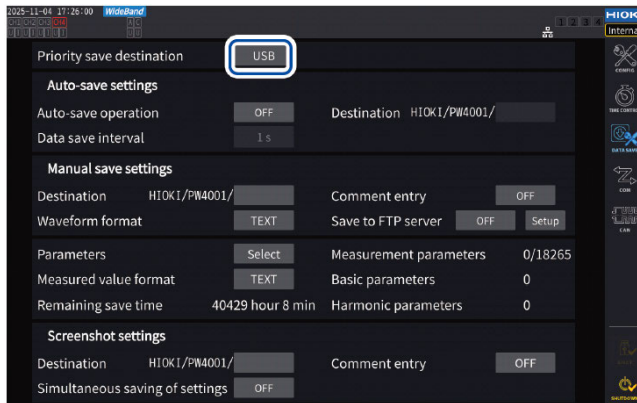

1 Tap the **[Priority save destination]** box to set the media to be saved to.

If no media is set as the **[Priority save destination]**, the save destination will automatically switch to the other type of media.

The media indicator is shown in the upper right corner of the screen. The text displayed in the media indicator indicates the current save destination. The indicator border lights up yellow while saving to media.

USB flash drive

	[USB] appears (background changes from gray to black). The instrument has recognized the USB flash drive.
	[USB] appears (background is red). Indicates the USB flash drive is more than 95% full. Stop measurement and then replace the USB flash drive with another one. Alternatively, transfer the data to your computer.
	[SLOW] appears. The instrument has recognized the USB flash drive as a drive with a slow write speed. The instrument will only be able to save about one-third of the maximum number of recordable parameters sampled for each interval time.
	[ERROR] appears. There is not enough space on the USB flash drive or it is not recognized.

Internal memory

	[INTERNAL] appears (background changes from gray to black). The data is saved in the internal memory.
	[INTERNAL] appears (background is red). Indicates the USB flash drive is more than 95% full. Stop measurement and transfer the data to your computer.
	[ERROR] appears. There is not enough space.

7.4 File Operation Screen

This section describes the File Operation screen. You cannot access the USB flash drive during auto-save operation.

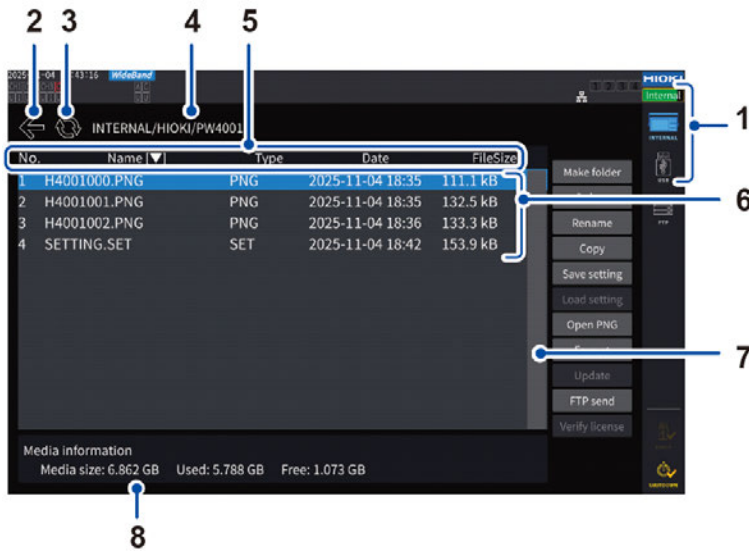

1	Select the media from which files will be accessed.
2	Takes you one level higher.
3	Updates the file list.
4	Displays the folder tree structure.
5	Tap the header row of the list to sort the files in the list according to their type. Example: Tapping [Date] sorts the files by creation date. Tapping [FileSize] sorts the files by size.
6	Lists the saved files.
7	Use to scroll when there are too many files to display on one screen or to change the display position.
8	Media information is displayed.

File types

Filename	Type	Description
M4001nnn.CSV	CSV	Manually saved measured data
MMDDnnkkk.CSV	CSV, BIN	Automatically saved measured data BIN format can only be loaded by GENNECT One.
W4001nnnkk.CSV	TEXT, BIN, MAT	Waveform data
PW4001.DBC	DBC	CAN database information
PW4001.JSON	JSON	Setting data of UDF1-20
H4001nnn.PNG	PNG	Screenshot image data
MMDDnn000.SET	SET	Automatically saved settings data
xxxxxxx.SET	SET	Settings data

Filename	Type	Description
xxxxxxx.A2L	A2L	A2L settings data
xxxxxxx.KEY	KEY	License key to enable the added function
xxxxxxx.CES	CES	Settings data created using the CAN editor for PW
xxxxxxx	FOLDER	Folder
xxxxxxx	???	File that cannot be controlled by the instrument

- In filenames, “nnn” or “nn” indicates sequential numbering in the folder (000 to 999 or 00 to 99); kk indicates the file segment number (000 to 999 or 00 to 99) for files larger than 500 MB; and MMDD indicates the month and day.
- Settings data filenames may be set as desired (up to eight characters).
- The File Operation screen can display only one-byte alphanumeric characters and symbols. Two-byte characters will be replaced by question marks (?).

Number of characters that can be used

Item to be entered	Maximum number of characters that can be entered
Folder name	8 alphanumeric characters and symbols
Comment	40 alphanumeric characters and symbols

Explore folders

- Tapping a line associated with a folder will display its contents.
- Tapping [←] at the top left will take you back one level higher in the tree structure.

Updating the contents of a folder

- Tap the circular arrow to update the displayed contents of the present folder.
- Use this when the file size differs from the actual size.

7.5 Saving Measured Data

There are two ways to save data: manually and automatically.

You can select data to be saved from among all measured values for basic measurement parameters and harmonic measurement parameters.

File format

Manual save	CSV format (data delimiter can be selected)
Auto-save	CSV format (data delimiter can be selected) or BIN format

Text format

Set the text saving format using the system screen.

🔍 See “6.1 Checking and Changing Settings” (p.189)

CSV	Measured data is saved comma-separated (,) format; the decimal point is represented by a period (.).
SSV	Measured data is saved semicolon-separated (;) format; the decimal point is represented by a comma (,).

IMPORTANT

- Data cannot be saved manually or automatically while the USB flash drive or internal memory is being accessed.
- When viewing a file created in text format using spreadsheet software, save the file under a different name. Overwriting may result in fewer significant digits of measured data.

Settings which measurement parameters to save

These settings affect both manual save and auto-save. Set which items will be saved to a USB flash drive or the internal memory.

The number of parameters that can be saved is subject to the following limits depending on the set intervals (p.212).

Data save interval	1 ms*1	10 ms	50 ms	100 ms	200 ms	500 ms	1 s	Others
Maximum number of recordable parameters (text)	50	200	1000	2000	4000	10000	20000	No limit
Maximum number of recordable parameters (binary)	400	4000	20000	40000	No limit	No limit	No limit	No limit

*1 When the data save interval is set to 1 ms, the harmonic measurement parameters cannot be selected.

Display screen: **SYSTEM** key > **[DATA SAVE]**

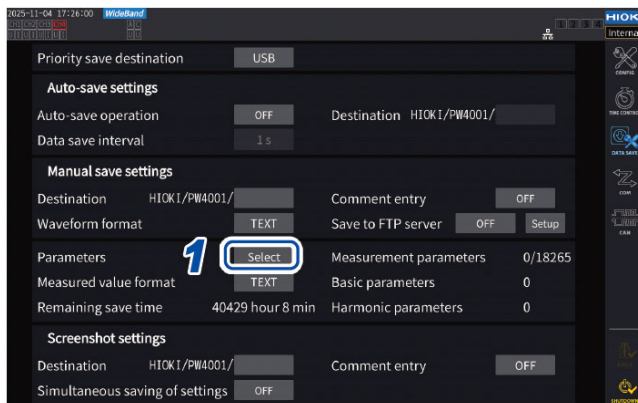

1 Tap the **[Parameters]** box to open the settings window.

7.5 Saving Measured Data

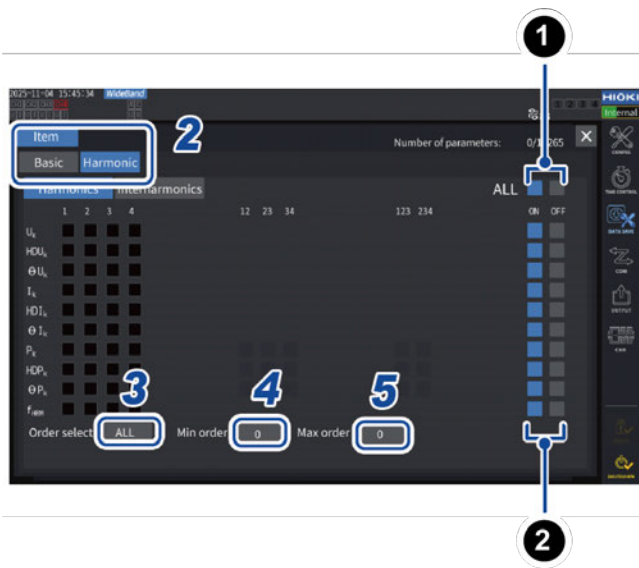

- 1 Tap here to switch between on and off for all items.
- 2 Tap here to switch between on and off for all items in that row.

- 2 Tap the parameters to be saved to select check boxes .

Basic	Basic measurement parameters
Harmonic	Harmonic measurement items

- 3 (When **Harmonic** is selected)

Tap the **Order Select** box and then select the rectifier from the list.

ALL	All orders
ODD	Odd-numbered orders
EVEN	Even-numbered orders

Regarding inter-harmonic, the orders 1.5, 3.5, 5.5, . . . are considered ODD, while the orders 0.5, 2.5, 4.5, . . . are considered EVEN.

- 4 Tap the **Min Order** box and then set the lowest order using the Y rotary knob.

Lit up in green: in 1 increments

Lit up in red: in 10 increments

See “Changing values with rotary knobs” (p.38)

In **WideBand** mode: 0 to 500

In **IEC** mode: 0 to 200

Setting such that a minimum order greater than the maximum order is not allowed.

- 5 Tap the **Max Order** box and then set the highest order using the Y rotary knob.

Lit up in green: in 1 increments

Lit up in red: in 10 increments

Tips To find out the times when operations were performed

Time data is always stored in measurement data files. The columns **[Date]**, **[Time]**, and **[Time (ms)]** represent the time data (at data intervals of less than 1 s).

When the measurement mode is set to **[IEC]**, along with them, the columns **[Date n]**, **[Time n]**, and **[Time (ms) n]** (at data intervals of less than 1 s, “n” represents the channel number) are shown.

To save measured data in milliseconds

If the data save interval is set to less than 1 s, the column **[Time (ms)]** is added to the saved file. Even if you save the integration elapsed time (the **[Elapsed Time]** check box in the others tab is selected), the **[ETime (ms)]** column is added if you set the data save interval to less than 1 s in the same way.

Manually saving measured data

Pressing the **SAVE** key saves measured values at that point in time. Set measured parameters to be saved and the save destination in advance.

Save destination	USB flash drive, internal memory
Filename	Automatically generated; filename extension: CSV M4001nnn.CSV (where “nnn” indicates sequential numbering in the folder from 000 to 999) Ex.: M4001000.CSV (the first file to be saved)
Remark	A new file is created when first saving data. Subsequently, the same file is appended.

Tips Saved data may differ from display values at the instant the **SAVE** key was pressed due to the time difference. To ensure saved data and on-screen values match, manually save data while using the hold function.

Display screen: **SYSTEM** key > **[DATA SAVE]**

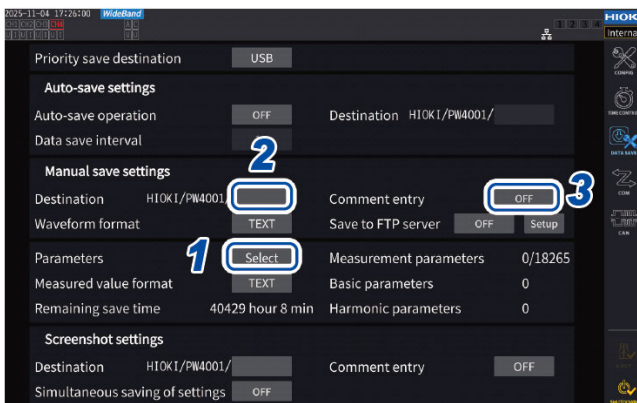

- 1 “Settings which measurement parameters to save” (p.207)
- 2 Tap the **[Destination]** box and use the keyboard window to specify the name of the folder.
(Up to 8 alphanumeric characters and symbols)
See “Keyboard window” (p.39)

- During auto-save operation, manual save operation cannot be performed.
- Up to 1000 files can be created in the same folder. When the sequential number used for files in the folder reaches 1000, an error will be displayed. Set a new destination folder.

- 3 To add a comment, tap the **[Comment entry]** box to set it to **[ON]**.
(Up to 40 alphanumeric characters and symbols)
- 4 Press the **SAVE** key when you wish to save data.
- 5 When Comment entry is set to ON, use the keyboard window to enter the comment.
The comment will be added to the end of the measured data in the CSV file.
- 6 Tap **[Enter]**.
The data is saved.

Timing at which new files are created

Once the following settings were changed or operation was performed, a new file will be created the next time data is saved:

Setting	Save destination folder Wiring mode Measured parameters to be saved, text saving format, and comment entry settings
Operation	Press the DATA RESET key. (This can be convenient when you wish to change the sequential numbering.)

Automatically saving measured data

This function automatically saves measured values at the set time. Parameters that have been set in advance will be saved.

Save destination	USB flash drive, internal memory
Filename	Automatically generated based on the time and date at start of saving with CSV or BIN extension for measured data or SET for settings data MMDDnnkkk.CSV, MMDDnn000.SET (MM: month, DD: date, nn: sequential number from 00 to 99 within the same folder, kkk: sequential number from 000 to 999 for file segments when the file size exceeds 500 MB) Example: 110400000.CSV (first file saved on November 4) See "Folder and file structure when saving data automatically" (p.215)

IMPORTANT

- If auto-save operation starts during manual save operation, waveform save operation, or screenshot operation, some data sets that should be saved may be discarded.
- No auto-save file is created when each wiring integration is enabled. (p.98)

Display screen: **SYSTEM** key > **[DATA SAVE]**



- 1 “Settings which measurement parameters to save” (p.207)
- 2 Tap the **[Auto-save operation]** box to set it to **[ON]**.
- 3 Tap the **[Data save interval]** box and then set the data saving interval.
The selections vary depending on the data update interval setting **[Meas. Interval]** (p.89).

(For the data update interval of 1 ms)

OFF, 1 ms, 10 ms, 50 ms, 100 ms, 200 ms, 500 ms, 1 s, 5 s, 10 s, 15 s, 30 s, 1 min, 5 min, 10 min, 15 min, 30 min, 60 min

(For the data update interval of 10 ms)

OFF, 10 ms, 50 ms, 100 ms, 200 ms, 500 ms, 1 s, 5 s, 10 s, 15 s, 30 s, 1 min, 5 min, 10 min, 15 min, 30 min, 60 min

(For the data update interval of 50 ms)

OFF, 50 ms, 100 ms, 200 ms, 500 ms, 1 s, 5 s, 10 s, 15 s, 30 s, 1 min, 5 min, 10 min, 15 min, 30 min, 60 min

(For the data update interval of 100 ms)

OFF, 100 ms, 200 ms, 500 ms, 1 s, 5 s, 10 s, 15 s, 30 s, 1 min, 5 min, 10 min, 15 min, 30 min, 60 min

(For the data update interval of 200 ms)

OFF, 100 ms^{*1}, 200 ms, 500 ms^{*1}, 1 s, 5 s, 10 s, 15 s, 30 s, 1 min, 5 min, 10 min, 15 min, 30 min, 60 min

*1 (only in IEC measurement mode)

- 4** Tap the **[Destination]** box and use the keyboard window to specify the name of the folder. (Up to 8 alphanumeric characters and symbols)

🔍 See “Keyboard window” (p.39)

- 5** Set the save time.

🔍 See “5.1 Time Control Function” (p.165), “Auto-save operation using time control” (p.216)

- 6** Press the **START/STOP** key.

Auto-save operation will start. The set folder will be created automatically, and data will be saved there.

- 7** Press the **START/STOP** key again to stop the auto-save operation.

Tips

- During auto-save operation, neither manual save operation nor waveform save operation can be performed.
- The maximum number of recordable parameters varies depending on the data save interval. The longer the data save interval becomes, the more the maximum number of recordable parameters becomes.
🔍 See “Settings which measurement parameters to save” (p.207), “Copying a file” (p.226)
- When the data update interval is set to 1 ms, the UDF value is an error, so an error value is saved.
- When the data save interval is set to 1 ms, harmonic measurements cannot be saved (they cannot be selected).

Recordable time and data

When **[Auto-save operation]** is set to **[ON]**, the remaining save time for the USB flash drive being used or the internal memory will be displayed. An estimate of the remaining save time is calculated based on the amount of usable space on the USB flash drive or internal memory, the number of parameters being recorded, and the data save interval.

Approximate recordable time for text format and common format

When the data output interval is set to 50 ms

Number of measurements parameters to be recorded per USB capacity	32 GB (1x)		64 GB (approx. 2x)		128 GB (approx. 4x)	
	Text	Binary	Text	Binary	Text	Binary
100	301 h	996 h	602 h	1992 h	1204 h	3984 h
200	158 h	517 h	316 h	1034 h	632 h	2068 h
500	65 h	212 h	130 h	424 h	260 h	848 h
1000	33 h	107 h	66 h	214 h	132 h	428 h
2000	-	54 h	-	108 h	-	216 h
5000	-	21 h	-	42 h	-	84 h

The table above does not take file segmentation into consideration. If file segmentation is considered, the recordable times will be slightly shorter.

In text format, one measured data set consists of up to 13 bytes; in binary format, one measured data set consists of four bytes.

Estimated data sizes of waveforms are as follows.

Volume of waveform data	Text format	Binary format
1 channel, 1000 points	26 kB	6 kB
1 channel, 5 megapoints	130 MB	20 MB
24 channels, 1000 points	456 kB	118 kB
24 channels, 5 megapoints	2270 MB	548 MB

Timing at which new files are created (timing at which files are segmented)

If data is being saved onto a USB flash drive or in the internal memory, a new file will be created when integration starts.

During integration recording or when saving waveform data, a new file will be created and the saved data will be segmented in the following cases:

Example 1: The size of a single file exceeds approximately 500 MB. (A maximum of 1000 files will be saved per measurement.)

Example 2: During integration, the **START/STOP** key is pressed to stop integration, the **DATA RESET** key is pressed to reset integration, and then the **START/STOP** key is pressed to start new integration. (A maximum of 100 files will be saved per folder.)

Example 3: If the number of data points per file exceeds one megasampling point.

Example 4: (Only when the saving format is set to binary format) During integration, the **START/STOP** key is pressed to pause integration, and then the **START/STOP** key is pressed again to resume integration.

Example 5: (Only when the saving format is set to binary format) The voltage range and current range are changed during integration.

See “Folder and file structure when saving data automatically” (p.215)

Folder and file structure when saving data automatically

The following explanation assumes that a folder named **[AAA]** has been created as the destination location so that data can automatically be saved on November 4.

Example 1

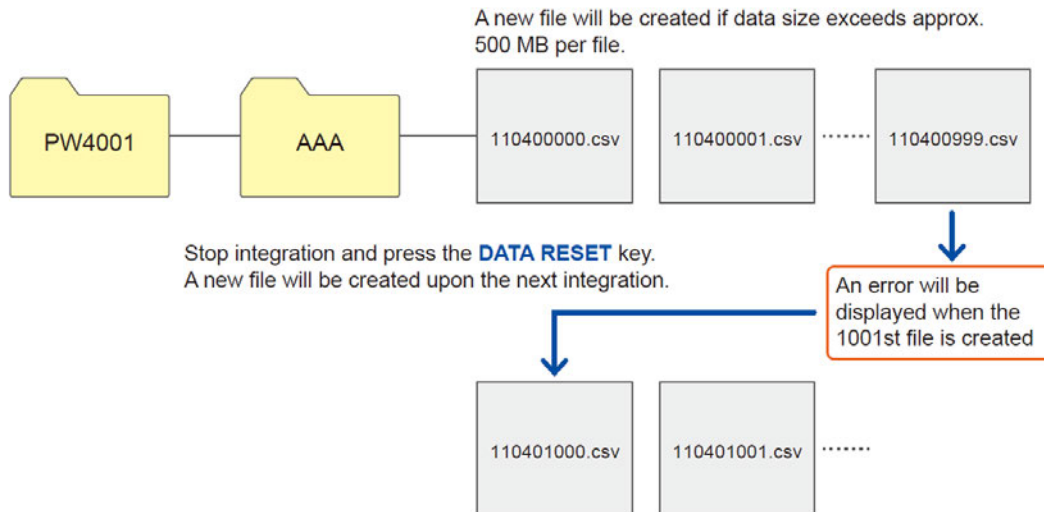

Example 2

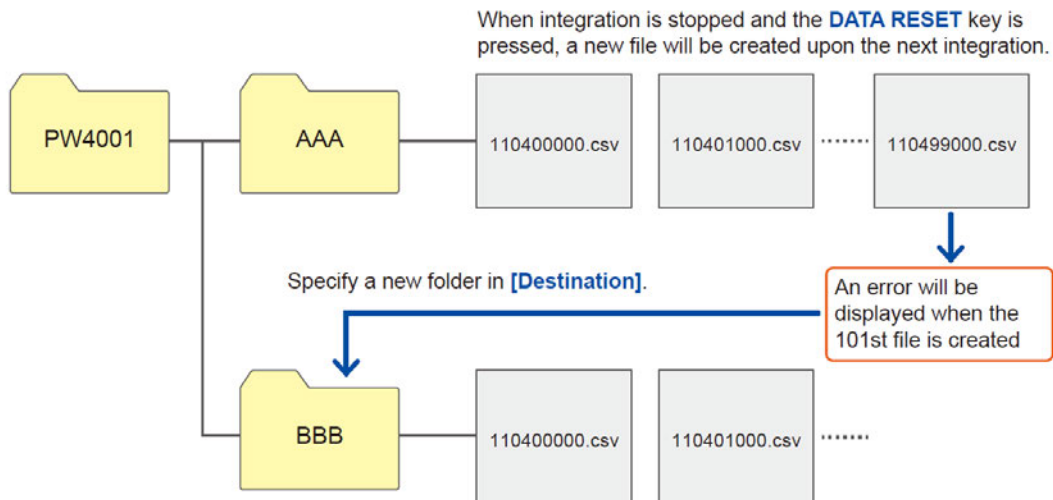

Auto-save operation using time control

Settings cannot be changed while time control is operating. If the USB flash drive or internal memory becomes full during auto-save operation, an error will be displayed, and no further data will be saved.

See “5.1 Time Control Function” (p.165)

Data save interval other than OFF

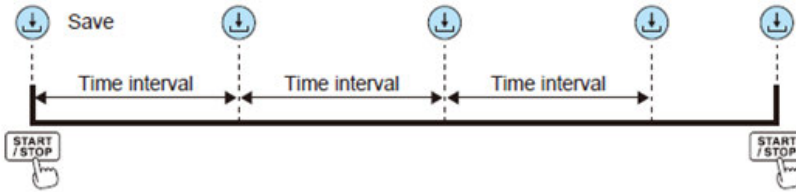

Timer control + Data save interval OFF

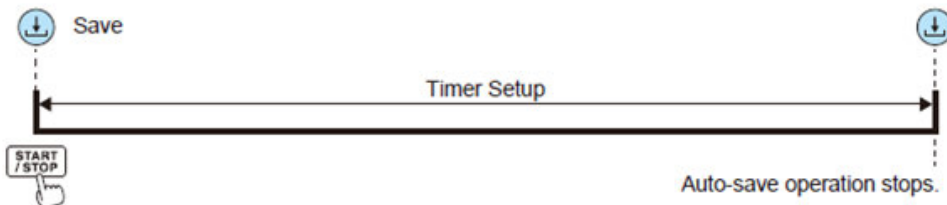

Real time control + Data save interval OFF

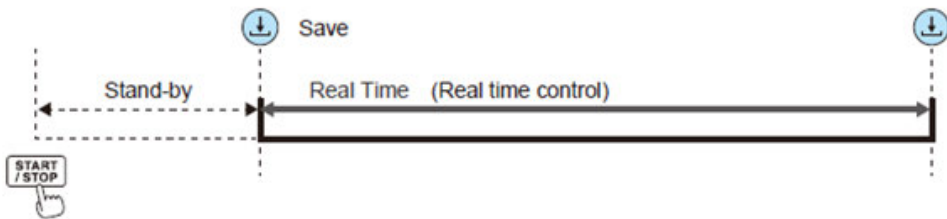

Timer control + Data save interval other than OFF

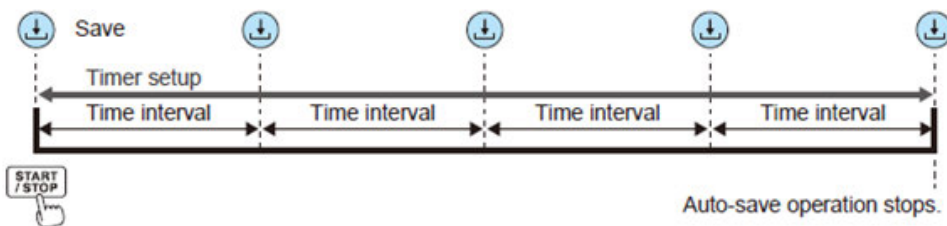

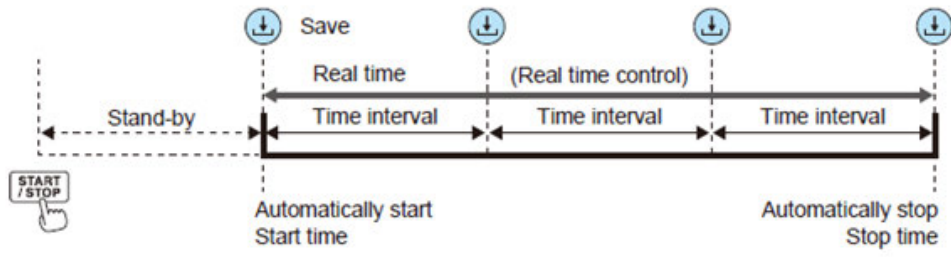
Real time control + Data save interval other than OFF

7.6 Saving Waveform Data

Waveform data displayed on the screen can be saved onto the USB flash drive by tapping **[SAVE]** via the **MEAS** key > **[WAVE]** screen.

The same **[Destination]** and **[Comment entry]** settings as those for manual saving of measured data are used.

Save destination	USB flash drive, internal memory
Filename	<p>Filenames are created automatically. The extension can be selected from among CSV, BIN or MAT (depending on the waveform saving format setting).</p> <ul style="list-style-type: none"> W4001nnnkk.CSV <p>(where “nnn” indicates the sequential number within the same folder, and kk indicates the file segment number) Ex.: W400100000.CSV (the first file to be saved)</p> <ul style="list-style-type: none"> W4001nnnkk.BIN <p>Ex.: W400100000.BIN (the first file to be saved)</p> <ul style="list-style-type: none"> W4001nnnkk.MAT

Save settings

Display screen: **SYSTEM** key > **[DATA SAVE]**

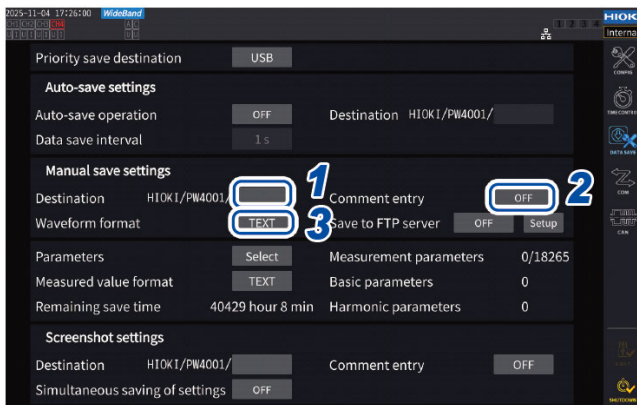

- 1 Tap the **[Destination]** box and set a filename using a keyboard.
(Up to 8 alphanumeric characters and symbols)
[See “Keyboard window” \(p.39\)](#)
- 2 Tap the **[Comment entry]** box to set it to ON or OFF.
- 3 Tap the **[Waveform format]** box and then select the desired format from the list.

TEXT	CSV format (text data)
BIN	Binary format, which can be displayed with the viewer of GENNECT One
MAT	MATLAB format (MAT format)

Up to 1000 files can be created in the same folder. When the sequential number used for files in the folder reaches 1000, an error will be displayed. Set a new destination folder.

Saving operation

Display screen: **MEAS** key > **[WAVE]**

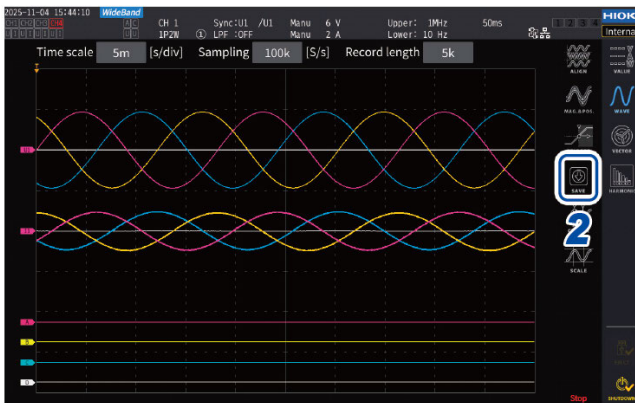

1 Tap the **SINGLE** key to acquire waveforms.

After waveforms of the recording length have been recorded, the **RUN/STOP** key lights up in red.

🔍 See “4.3 Recording Waveforms” (p.159)

2 Tap **[SAVE]** > **[Waveforms]**.

If the instrument has not recognized the USB flash drive, the button will be dimmed so that you cannot tap it.

3 When Comment entry is set to ON, use the keyboard window to enter the comment.

(Up to 40 alphanumeric characters and symbols)

🔍 See “Keyboard window” (p.39)

Once you confirm the comment, the data will be saved.

The following strings will be added before measured data in the CSV file:

- SAMPLING (sampling speed)
 - POINT (recording length)
 - COMMENT (entered comment string)
- You may not be able to save the waveform if it was acquired by pressing the **RUN/STOP** key.
 - For more information about saving BIN files, see “7.11 BIN Saving Format” (p.238).
 - Parameters for which the waveform display is set to OFF will not be saved.
 - Waveform data cannot be saved while auto-save operation is in progress.
 - Waveform data of voltage, current, and motor analysis option will be saved as a set of the maximum and minimum data compressed using the peak-to-peak compression.
 - A confirmation dialog box is displayed when saving. To cancel save operation, tap **[Cancel]** in the dialog box.

7.7 Saving and Loading Screenshots

Saving screenshots

You can save a screenshot as a PNG file on a USB flash drive or in the internal memory by pressing the **SCREEN SHOT** key.

Screenshots can be saved during auto-save operation. However, auto-save operation will have priority, and screenshots cannot be made when the interval is set to less than 1 s.

Save destination

Saves to a USB flash drive or the internal memory.

Filename

Filenames are created automatically. The file extension is PNG.

M4001nnn.PNG (where “nnn” indicates sequential numbering in the folder from 000 to 999)

Ex.: M4001000.PNG (the first file to be saved)

Display screen: **SYSTEM** key > **[DATA SAVE]**

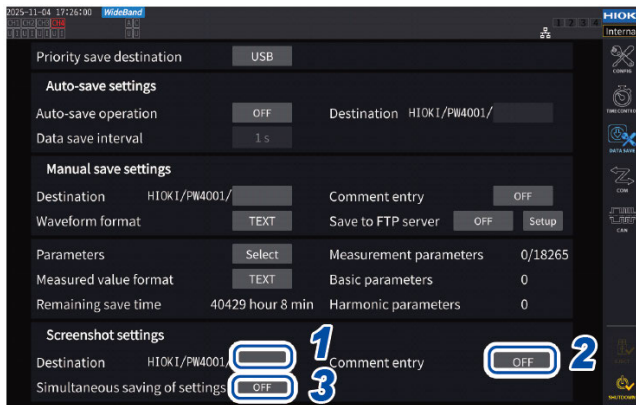

Up to 1000 files can be created in the same folder. When the sequential number used for files in the folder reaches 1000, an error will be displayed. Set a new destination folder.

1 Tap the **[Destination]** box to specify a folder.
(Up to 8 alphanumeric characters and symbols)
See “Keyboard window” (p.39)

2 Tap the **[Comment entry]** box to select an entry way.
(Up to 40 alphanumeric characters and symbols)

OFF	Disables comment entry.
TEXT	Allows you to enter comments with the keyboard window.
PNG	Allows you to enter comments as handwriting on the screen. (Comments will be added to the screenshot and saved.)

3 Tap the **[Simultaneous saving of settings]** box to select ON or OFF.

OFF	Disables saving of settings information.
ON	Saves a screenshot of each channel's measurement condition settings.

4 Press the **SCREEN SHOT** key and then enter a comment.

(If you select TEXT)

This allows you to enter a comment using the keyboard window.
Once you confirm the comment, the screenshot will be saved.

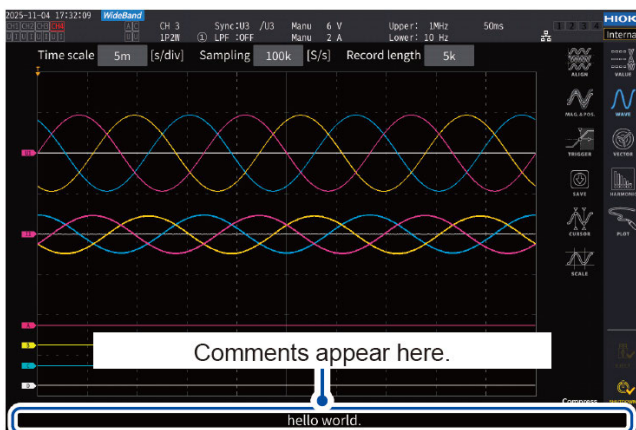

7.7 Saving and Loading Screenshots

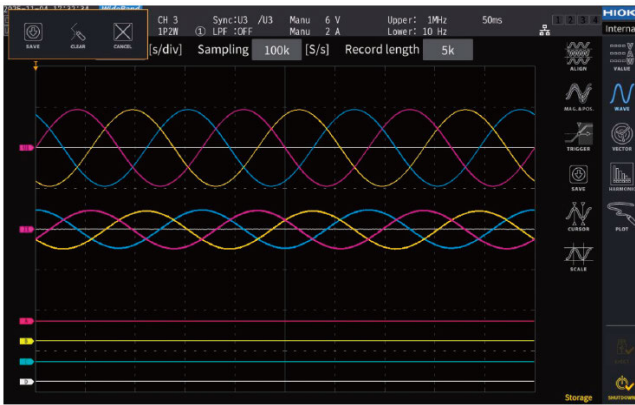

(If you select PNG)

This allows you to enter a comment in handwriting. Tapping **[SAVE]** can save the screenshot along with your hand-written comment.

Tapping **[CLEAR]** can clear your hand-written comment.

Tapping **[CANCEL]** can stop to save the data.

Loading a screenshot

You can load saved screenshots to display them.

Display screen: **FILE** key

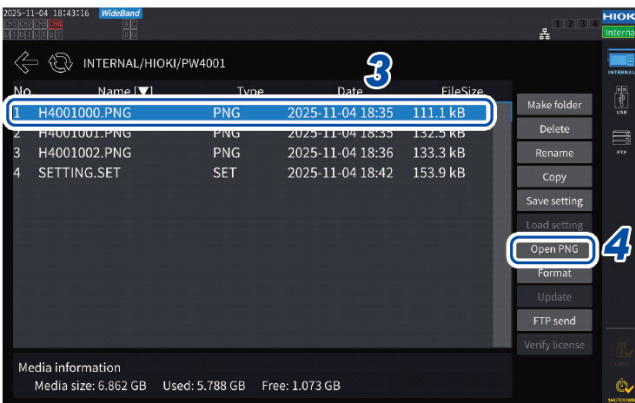

1 Press the **FILE** key.

2 Tap the folder that contains screenshots.

3 Tap a PNG file.

4 Tap **[Open PNG]**.

7.8 Saving and Loading the Settings Data

Saving settings data

Saves various information on instrument settings as a settings file.

Save destination	USB flash drive, internal memory
Filename	Optional (up to eight characters), with SET extension. (Example: SETTING1.SET)

Display screen: **FILE** key

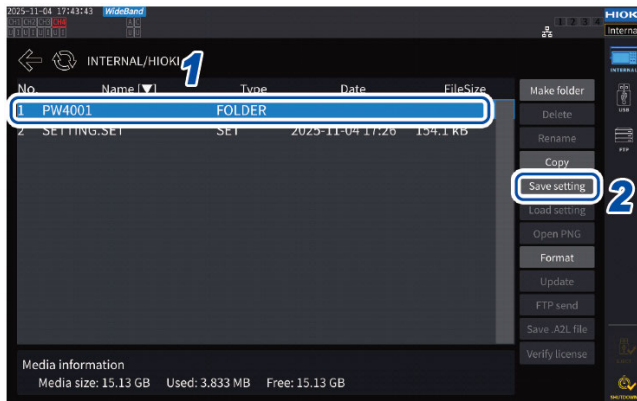

1 Tap the folder in which you wish to save the file.

2 Tap **[Save Setting]** and then enter a filename.

🔍 See “Keyboard window” (p.39)

- Language and communications settings cannot be saved.
- Filenames cannot be saved while auto-saving is in progress.

Loading settings data

You can load a saved settings file to restore the settings.

Display screen: **FILE** key

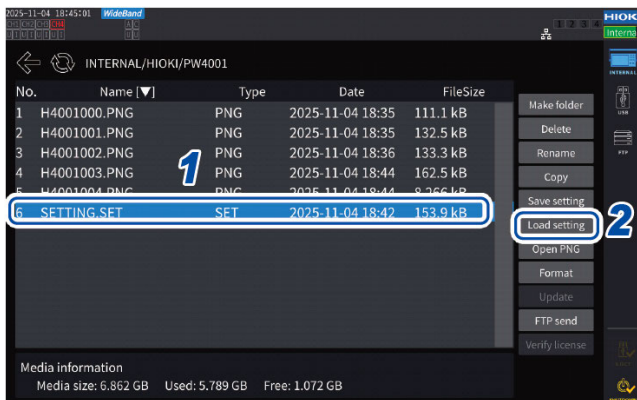

1 Tap the folder in which settings files are saved.

2 Select the settings file and then tap **[Load Setting]**.

A confirmation dialog box is displayed.

3 Tap **[Yes]**.

To restore the settings, the present module and options configurations must be the same as those in the settings file. If the configuration is different, the settings file cannot be loaded.

If the current sensor configuration in the configuration file to be loaded is different from the present current sensor configuration of the PW4001 of which you wish to restore the settings, the following settings are not restored.

- Wiring settings
- Settings related of current sensors

After loading the settings file, check the restored settings again.

7.8 Saving and Loading the Settings Data

Checking settings data

Check the various settings data stored in the settings file.

- 1** Press the **FILE** key.
- 2** Tap the folder in which settings files are saved.
- 3** Select the settings file and then tap **[Open PNG]**.



Checking settings data on a computer

You can also check the settings data stored on a computer using a general-purpose test viewer.

7.9 File and Folder Operation

File and folder operation with a USB flash drive or the internal memory

This section describes how to manage files and folders created on a USB flash drive or in the internal memory.

Display screen: **FILE** key

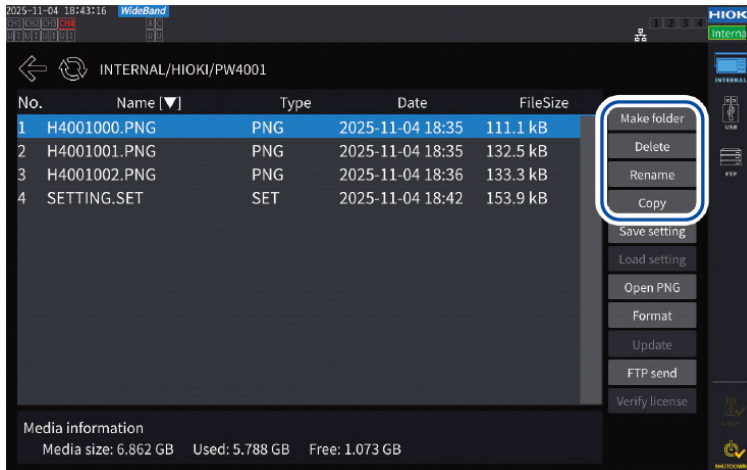

Creating a folder

- 1 Tap **[Make Folder]** to open the keyboard window.
- 2 Enter the folder name (up to eight characters in length).
 🔍 See “Keyboard window” (p.39)
- 3 Tap **[Enter]** to close the keyboard window.

Deleting a file or folder

- 1 Tap a file or a folder you wish to delete.
- 2 Tap **[Delete]**.
 A confirmation dialog box is displayed.
- 3 Select **[Yes]**.
 The HIOKI and HIOKI/PW4001 folders cannot be deleted.

Renaming a file or folder

- 1 Tap a file or a folder you wish to rename.
- 2 Tap **[Rename]** and then enter a filename (up to eight characters).

 See “Keyboard window” (p.39)

Copying a file

1 Tap **[Copy]** to open the copy destination folder selection dialog box.

2 Select the copy destination folder and then tap **[Yes]**.

If a file with the same name exists, it cannot be overwritten. Rename the file and then copy it.

Formatting a USB flash drive or the internal memory

This section describes how to format a USB flash drive or the internal memory. Always disconnect the instrument from an FTP server before formatting a USB flash drive.

Display screen: **FILE** key



1 Insert the USB flash drive in the instrument.

2 Tap **[Format]** to start formatting the USB flash drive.

Once formatting is complete, a folder named **[HIOKI/PW4001]** will be created automatically in the top level of the tree structure.

IMPORTANT

Formatting a USB flash drive or the internal memory will erase all data stored on the media. This operation cannot be undone. Check the contents of the drive carefully before formatting it. It is recommended to back up important data stored on USB flash drives and in the internal memory.

Manual file transfer (uploading to an FTP server)

You can upload a selected file onto an FTP server.

- 1** Press the **FILE** key.
- 2** Select the file you wish to transfer.
- 3** Tap **[FTP send]** to open the FTP client settings dialog box.
- 4** Set the FTP client.
 🔍 See "9.5 Sending Data Using the FTP Client Function" (p.298)
- 5** Tap **[Send]**.

7.10 Measured Value Save Data Format

Header structure

The following header information (which consists of parameter names saved in the first line of the file) is used when measured data is automatically or manually saved in a file.

- The selected parameters are outputted beginning from top to bottom and from left to right of the table.
- Measured data is outputted starting from the first line immediately below the header in the header order.
- The first four parameters (Date, Time, Status, and Status 1 to Status 4) and the harmonic status (HARM Status) are always outputted regardless of whether they have been selected.
- If the motor analysis option is installed, the status (Status M) of the motor channel is outputted.

Output parameters	Instrument symbol	Header and order
yy/MM/dd	-	Date
Time		Time
Time (ms)		Time (ms) (Output only with the interval setting of less than 1 s)
Elapsed time		Etime
Elapsed time (ms)		Etime (ms) (Output only with the interval setting of less than 1 s)
Year, month, and day of the start the flicker calculation period* ¹		Date1, Date2, Date3, Date4
Start time of the flicker calculation period* ¹		Time1, Time2, Time3, Time4
Start time of the flicker calculation period (ms)* ¹		Time (ms) 1, Time (ms) 2, Time (ms) 3, Time (ms) 4 (Output only with the interval setting of less than 1 s)
Status		Status
Channel status		Status1, Status2, Status3, Status4
Motor status		StatusM
Basic measurement items		
Voltage RMS value	Urms	Urms1, Urms2, Urms3, Urms4 Urms12, Urms23, Urms34 Urms123, Urms234
RMS equivalent of voltage average rectified value	Umn	Umn1, Umn2, Umn3, Umn4 Umn12, Umn23, Umn34 Umn123, Umn234
Voltage AC component	Uac	Uac1, Uac2, Uac3, Uac4
Voltage simple average	Udc	Udc1, Udc2, Udc3, Udc4
Voltage fundamental wave component	Ufnd	Ufnd1, Ufnd2, Ufnd3, Ufnd4
Voltage waveform peak (+)	Upk+	PUpk1, PUpk2, PUpk3, PUpk4
Voltage waveform peak (-)	Upk-	MUpk1, MUpk2, MUpk3, MUpk4
Total voltage harmonic distortion	Uthd	Uthd1, Uthd2, Uthd3, Uthd4

Output parameters	Instrument symbol	Header and order
Voltage ripple factor	Urf	Urf1, Urf2, Urf3, Urf4
Voltage unbalance rate	Uunb	Uunb123, Uunb234
Current RMS value	Irms	Irms1, Irms2, Irms3, Irms4 Irms12, Irms23, Irms34 Irms123, Irms234
RMS equivalent of average rectified current value	Imn	Imn1, Imn2, Imn3, Imn4 Imn12, Imn23, Imn34 Imn123, Imn234
Current AC component	lac	lac1, lac2, lac3, lac4
Current simple average	Idc	Idc1, Idc2, Idc3, Idc4
Current fundamental wave component	Ifnd	Ifnd1, Ifnd2, Ifnd3, Ifnd4
Current waveform peak (+)	lpk+	Plpk1, Plpk2, Plpk3, Plpk4
Current waveform peak (-)	lpk-	Mlpk1, Mlpk2, Mlpk3, Mlpk4
Total harmonic current distortion	lthd	lthd1, lthd2, lthd3, lthd4
Current ripple factor	lrf	lrf1, lrf2, lrf3, lrf4
Current unbalance rate	lunb	lunb123, lunb234
Active power	P	P1, P2, P3, P4 P12, P23, P34 P123, P234
Fundamental wave active power	Pfnd	Pfnd1, Pfnd2, Pfnd3, Pfnd4 Pfnd12, Pfnd23, Pfnd34 Pfnd123, Pfnd234
Apparent power	S	S1, S2, S3, S4 S12, S23, S34 S123, S234
Fundamental wave apparent power	Sfnd	Sfnd1, Sfnd2, Sfnd3, Sfnd4 Sfnd12, Sfnd23, Sfnd34 Sfnd123, Sfnd234
Reactive power	Q	Q1, Q2, Q3, Q4 Q12, Q23, Q34 Q123, Q234
Fundamental wave reactive power	Qfnd	Qfnd1, Qfnd2, Qfnd3, Qfnd4 Qfnd12, Qfnd23, Qfnd34 Qfnd123, Qfnd234
Power factor	λ	PF1, PF2, PF3, PF4 PF12, PF23, PF34 PF123, PF234
Fundamental wave power factor	λ fnd	PFfnd1, PFfnd2, PFfnd3, PFfnd4 PFfnd12, PFfnd23, PFfnd34 PFfnd123, PFfnd234
Voltage phase angle	θ_U	Udeg1, Udeg2, Udeg3, Udeg4

7.10 Measured Value Save Data Format

Output parameters	Instrument symbol	Header and order
Current phase angle	θI	Ideg1, Ideg2, Ideg3, Ideg4
Power phase angle	\emptyset	DEG1, DEG2, DEG3, DEG4 DEG12, DEG23, DEG34 DEG123, DEG234
Voltage frequency	fU	FU1, FU2, FU3, FU4
Current frequency	fI	FI1, FI2, FI3, FI4
Integrated positive current value	Ih+	PIH1, PIH2, PIH3, PIH4
Integrated negative current value	Ih-	MIH1, MIH2, MIH3, MIH4
Sum of positive and negative current values	Ih	IH1, IH2, IH3, IH4
Integrated positive power value	WP+	PWP1, PWP2, PWP3, PWP4 PWP12, PWP23, PWP34 PWP123, PWP234
Integrated negative power value	WP-	MWP1, MWP2, MWP3, MWP4 MWP12, MWP23, MWP34 MWP123, MWP234
Sum of integrated positive and negative power values	WP	WP1, WP2, WP3, WP4 WP12, WP23, WP34 WP123, WP234
Efficiency	η	Eff1, Eff2, Eff3, Eff4
Loss value	Loss	LOSS1, LOSS2, LOSS3, LOSS4
Torque	Tq	Tq1, Tq2
RPM	Spd	Spd1, Spd2
Motor power	Pm	Pm1, Pm2
Slip	Slip	Slip1, Slip2
Free input during independent input mode operation	Channel	Ch. A, Ch. B, Ch. C, Ch. D
User-defined calculation	UDF	UDF1, UDF2, UDF3, UDF4, UDF5, UDF6, UDF7, UDF8, UDF9, UDF10, UDF11, UDF12, UDF13, UDF14, UDF15, UDF16, UDF17, UDF18, UDF19, UDF20
Short-term flicker value*1	Pst	Pst1, Pst2, Pst3, Pst4
Maximum short-term flicker value*1	PstMax	PstMax1, PstMax2, PstMax3, PstMax4
Long-term flicker value*1	Plt	Plt1, Plt2, Plt3, Plt4
Maximum instantaneous flicker value*1	PinstMax	PinstMax1, PinstMax2, PinstMax3, PinstMax4
Minimum instantaneous flicker value*1	PinstMin	PinstMin1, PinstMin2, PinstMin3, PinstMin4
Relative steady-state voltage change*1	dc	DC1, DC2, DC3, DC4

Output parameters		Instrument symbol	Header and order
Maximum relative voltage change*1		dmax	DMax1, DMax2, DMax3, DMax4
Period during which the relative voltage change exceeds the threshold*1		Tmax	TMax1, TMax2, TMax3, TMax4
CAN input value		CAN	CAN1, CAN2, CAN3, CAN4, CAN5, CAN6, CAN7, CAN8, CAN9, CAN10, CAN11, CAN12, CAN13, CAN14, CAN15, CAN16, CAN17, CAN18, CAN19, CAN20
Harmonic measurement parameters			
Status			HRMStatus
0th order	Harmonic voltage RMS value	Uk	HU1L000, HU2L000, HU3L000, HU4L000
	Harmonic voltage content percentage	HDUk	HU1D000, HU2D000, HU3D000, HU4D000
	Harmonic voltage phase angle	θ_{Uk}	HU1P000, HU2P000, HU3P000, HU4P000
	Harmonic current RMS value	Ik	HI1L000, HI2L000, HI3L000, HI4L000
	Harmonic current content percentage	HDIk	HI1D000, HI2D000, HI3D000, HI4D000
	Harmonic current phase angle	θ_{Ik}	HI1P000, HI2P000, HI3P000, HI4P000
	Harmonic active power	Pk	HP1L000, HP2L000, HP3L000, HP4L000, HP12L000, HP23L000, HP34L000, HP123L000, HP234L000
	Harmonic power content percentage	HDPk	HP1D000, HP2D000, HP3D000, HP4D000, HP12D000, HP23D000, HP34D000, HP123D000, HP234D000
	Harmonic voltage/current phase difference	θ_k	HP1P000, HP2P000, HP3P000, HP4P000, HP12P000, HP23P000, HP34P000, HP123P000, HP234P000
nth order	(an omission)	-	The last three digits represent the order n.

7.10 Measured Value Save Data Format

Output parameters		Instrument symbol	Header and order
500th	Harmonic voltage RMS value	Uk	HU1L500, HU2L500, HU3L500, HU4L500
	Harmonic voltage content percentage	HDUK	HU1D500, HU2D500, HU3D500, HU4D500
	Harmonic voltage phase angle	θUk	HU1P500, HU2P500, HU3P500, HU4P500
	Harmonic current RMS value	Ik	HI1L500, HI2L500, HI3L500, HI4L500
	Harmonic current content percentage	HDIk	HI1D500, HI2D500, HI3D500, HI4D500
	Harmonic current phase angle	θIk	HI1P500, HI2P500, HI3P500, HI4P500
	Harmonic active power	Pk	HP1L500, HP2L500, HP3L500, HP4L500, HP12L500, HP23L500, HP34L500, HP123L500, HP234L500
	Harmonic power content percentage	HDPk	HP1D500, HP2D500, HP3D500, HP4D500, HP12D500, HP23D500, HP34D500, HP123D500, HP234D500
	Harmonic voltage/current phase difference	θk	HP1P500, HP2P500, HP3P500, HP4P500, HP12P500, HP23P500, HP34P500, HP123P500, HP234P500
	Harmonic synchronization frequency	fHRM	HF1, HF2, HF3, HF4
0.5th order	Inter-harmonic voltage RMS value*1	iUk	IHU1L000, IHU2L000, IHU3L000, IHU4L000
0.5th order	Inter-harmonic voltage content percentage*1	iHDUK	IHU1D000, IHU2D000, IHU3D000, IHU4D000
0.5th order	Inter-harmonic current RMS value*1	iIk	IHI1L000, IHI2L000, IHI3L000, IHI4L000
0.5th order	Inter-harmonic current content percentage*1	iHDIk	IHI1D000, IHI2D000, IHI3D000, IHI4D000
nth order	(an omission)*1	-	The last three digits represent the order n.
200.5th order	Inter-harmonic voltage RMS value*1	iUk	IHU1L200, IHU2L200, IHU3L200, IHU4L200
200.5th order	Inter-harmonic voltage content percentage*1	iHDUK	IHU1D200, IHU2D200, IHU3D200, IHU4D200
200.5th order	Inter-harmonic current RMS value*1	iIk	IHI1L200, IHI2L200, IHI3L200, IHI4L200
200.5th order	Inter-harmonic current content percentage*1	iHDIk	IHI1D200, IHI2D200, IHI3D200, IHI4D200

*1 (only in IEC measurement mode)

Status data

Status information is used to express measurement conditions at the time the measured data was saved using 32-bit hexadecimal values.

Status is the logical sum of Status 1 to Status 4, as well as Status M.

Example: If Bit 11 (ZU) of Status 2 is on and Bit 17 (ZM) of Status M is on, Bit 11 and Bit 17 of Status will be set to on.

Status of each channel (Status 1 through Status 4)

Status 1 through Status 4 indicate the status of individual channels.

Example: Status 3 indicates the status of channel 3.

Each of the 32 bits is assigned to contain the following information:

Bit 31	Bit 30	Bit 29	Bit 28	Bit 27	Bit 26	Bit 25	Bit 24
–	–	–	–	–	–	–	–
Bit 23	Bit 22	Bit 21	Bit 20	Bit 19	Bit 18	Bit 17	Bit 16
–	–	–	–	–	–	–	–
Bit 15	Bit 14	Bit 13	Bit 12	Bit 11	Bit 10	Bit 9	Bit 8
–	UCU	ZP	ZI	ZU	DP	DI	DU
Bit 7	Bit 6	Bit 5	Bit 4	Bit 3	Bit 2	Bit 1	Bit 0
–	–	–	–	RI	RU	PI	PU

Bit	Abbreviation	Description
Bit 14	UCU	Calculation not possible (for example, measurement data was invalid because it was sampled immediately after range switching.)
Bit 13	ZP	Power calculation (synchronization source) forced zero-crossing
Bit 12	ZI	Current frequency forced zero-crossing
Bit 11	ZU	Voltage frequency forced zero-crossing
Bit 10	DP	No power calculation (synchronization source) data update
Bit 9	DI	No current frequency data update
Bit 8	DU	No voltage frequency data update
Bit 3	RI	Current overload
Bit 2	RU	Voltage overload
Bit 1	PI	Current peak-over
Bit 0	PU	Voltage peak-over

Example: When Bit 12 (ZI, current frequency forced zero-crossing) and Bit 2 (RU, voltage overload) are enabled, the status is represented as 1004 in hexadecimal notation.

For reference, the representation in binary would be 00000000000000000000100000000100.

Motor channel status (Status M)

Each of the 32 bits is assigned to contain the following information:

Bit 31	Bit 30	Bit 29	Bit 28	Bit 27	Bit 26	Bit 25	Bit 24
–	–	–	–	–	–	–	–
Bit 23	Bit 22	Bit 21	Bit 20	Bit 19	Bit 18	Bit 17	Bit 16
–	–	UCUC	ZMC	RMC	UCUA	ZMA	RMA
Bit 15	Bit 14	Bit 13	Bit 12	Bit 11	Bit 10	Bit 9	Bit 8
–	–	–	–	–	–	–	–
Bit 7	Bit 6	Bit 5	Bit 4	Bit 3	Bit 2	Bit 1	Bit 0
–	–	–	–	–	–	–	–

Bit	Abbreviation	Description
Bit 21	UCUC	Ch. C calculation not possible (for example, measurement data was invalid because it was sampled immediately after range switching.)
Bit 20	ZMC	Ch. C motor synchronization source forced zero-crossing
Bit 19	RMC	Overload while using Ch. C analog input
Bit 18	UCUA	Ch. A calculation not possible (for example, measurement data was invalid because it was sampled immediately after range switching.)
Bit 17	ZMA	Ch. A motor synchronization source forced zero-crossing
Bit 16	RMA	Overload while using Ch. A analog input

Harmonic status (HARM Status)

Status information expresses measurement conditions at the time the measured data was saved using a 32-bit hexadecimal value.

The status of the measured harmonics data is one of the Status blocks.

Each of the 32 bits is assigned to contain the following information: (numbers 1 through 4 at the end of the abbreviation indicate the channel numbers.)

Bit 31	Bit 30	Bit 29	Bit 28	Bit 27	Bit 26	Bit 25	Bit 24
–	–	–	–	–	–	–	–
Bit 23	Bit 22	Bit 21	Bit 20	Bit 19	Bit 18	Bit 17	Bit 16
–	–	–	–	UCU4	UCU3	UCU2	UCU1
Bit 15	Bit 14	Bit 13	Bit 12	Bit 11	Bit 10	Bit 9	Bit 8
–	–	–	–	ZH4	ZH3	ZH2	ZH1
Bit 7	Bit 6	Bit 5	Bit 4	Bit 3	Bit 2	Bit 1	Bit 0
–	–	–	–	RF4	RF3	RF2	RF1

7.10 Measured Value Save Data Format

Bit	Abbreviation	Description
Bit 16 to bit 19	UCU	Calculation not possible (for example, measurement data was invalid because it was sampled immediately after range switching.)
Bit 8 to bit 11	ZH	Harmonic waveform forced zero-crossing
Bit 0 to bit 3	RF	The frequency exceeds the range.

Data format for measured values

General measured values	±□□□□□□□E±□□ 7-digit mantissa including the decimal point and 2-digit exponent (The plus sign at the beginning of the mantissa and any leading zeroes are omitted.)	
Integrated values	±□□□□□□□E±□□ 7-digit mantissa including the decimal point and 2-digit exponent (The plus sign at the beginning of the mantissa and any leading zeroes are omitted.)	
Date and time	yy/MM/dd hh/mm/ss Elapsed time Elapsed time (ms)	□□□□/□□/□□ □□:□□:□□ □□□□:□□:□□ □□□
Errors	Over value	When [-----] is displayed due to an overload or peak-over, the value +99999.9E+99 is saved.
	Error value	When [-----] is displayed due to a range change or operation impossible value, the value +77777.7E+99 is saved.

7.11 BIN Saving Format

BIN format, which can be selected as the saving format for automatically saved files and for waveform files, can only be loaded by GENNECT One.

For more information about GENNECT One, see “9.8 GENNECT One (PC Application Software)” (p.311).

8

Connecting External Devices

8.1 Synchronous Measurement

You can use BNC synchronization mode to perform synchronous measurements on multiple PW4001 instruments. The data update timing and control of the secondary instruments are synchronized with the primary instrument.

Synchronous mode	Description	Number of synchronizable instruments
BNC synchronization	Only timings, such as data update, integration, and HOLD, can be synchronized.	Up to eight (one primary, up to seven secondaries)

BNC synchronization

Connecting up to eight PW4001 instruments using the optional 9165 Connection Cable (BNC cables) allows the instruments to perform synchronous measurement. Using this function to operate the primary PW4001 instrument can control the secondary PW4001 instruments, enabling simultaneous measurements on multiple systems.

The secondary PW4001 instruments operate in sync with the timings and operation of the primary PW4001 instrument for the following:

- Internal calculations and data updates
- Starting/stopping integration and resetting integrated values
- Freezing displays (**HOLD/PEAK HOLD**) and updating data during the display freeze
- Zero adjustment
- **SAVE**
- **SCREEN SHOT**
- Present time

Connecting the instruments

CAUTION



- **Do not input signals other than those dedicated to the synchronous measurement.**
The synchronous measurement uses signals dedicated to the instruments. Doing so could damage the instruments or cause them to malfunction.



- **Use the common earthing for the PW4001 instruments under synchronous measurement.**
Earthing to the different points causes a potential difference between the GND terminals of any two of the primary and secondary instruments. Connecting the connection cables (for synchronizing) while there is a potential difference could cause a malfunction or damage to the instruments.

During synchronous measurements, control signals are transmitted via the 9165 Connection Cable. Never disconnect the connection cables during synchronous measurements. Doing so disrupts signals, possibly causing the secondary instrument to go out of control.

8.1 Synchronous Measurement

You will need: PW4001 × 2, 9165 Connection Cable × 1

- 1 Make sure that the two PW4001 instruments have been turned off.
- 2 Connect the EXT SYNC terminals of the two PW4001 instruments using the 9165 Connection Cable (1).
- 3 Turn the two PW4001 on (any order).

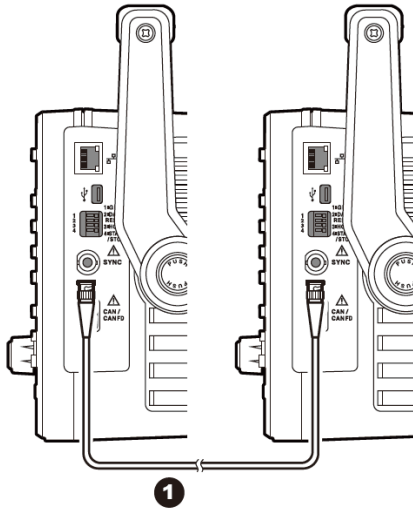

Performing synchronous measurement with three or more PW4001 instruments

Use BNC T-shaped adapters (plug-to-two jacks) (2) to connect the instruments in parallel.

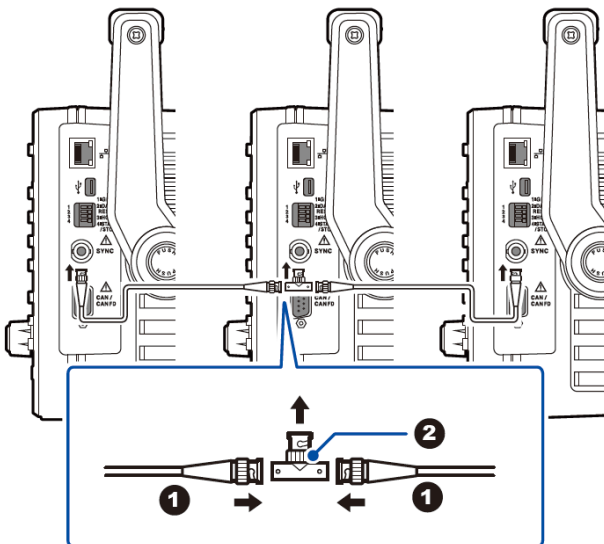

Making synchronous measurement settings

Display screen: **SYSTEM** key > **[COM]**

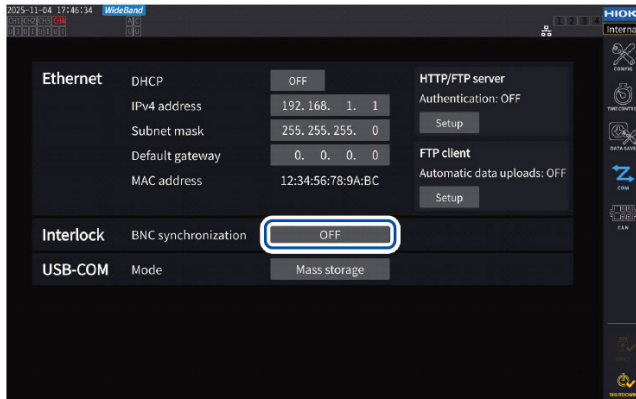

1 Tap the **[BNC synchronization]** box under **[Interlock]**.

You can check the sync status with the operation status indicator in the upper right of the screen.

See “Common screen display” (p.41)

Sync Primary (blue)	Set as the primary instrument in BNC synchronization mode
Sync Secondary (white)	Set as a secondary instrument in BNC synchronization mode
Sync Primary (red)	Synchronization error

IMPORTANT

- Set only one instrument as the primary for the synchronous measurement.
- Match the measurement mode and data update interval between the primary and the secondary instruments, reset the integrated values, and then start synchronous measurements.
- The instruments cannot be synchronized if a discrepancy in the measurement mode and data update interval is found between the primary and secondary instruments or the integrated values have not been reset.
- During synchronous measurements, the above items synchronized with those of the primary instrument cannot be controlled or set using the secondary instruments.
- Note that if a synchronization error occurs while the integration is being performed or stopped, the secondary instruments stop the integration immediately, resetting the integrated values.
- Note that if a synchronization error occurs while a hold or peak-hold functions is activated, the secondary instruments deactivate the hold or peak-hold function.

8.2 Waveform/Analog Output (Waveform and D/A Output Option)

This instrument's waveform and D/A output option includes analog output of freely-selected measured values as well as unmodified voltage and current waveforms.

The analog output can be used to record fluctuations over extended periods of time based on the data update interval.

The waveform output generates output of voltage and current waveforms sampled at a rate of 2.5 MS/s without modification at a rate of 1 MS/s, allowing the waveforms to be observed through another device, such as an oscilloscope.

Connecting external devices

This section describes how to connect an application-specific device (for example, an oscilloscope, data logger, or recorder) to the instrument's D/A output terminal using its D-sub connector.

To ensure safe operation, be sure to turn off the instrument and device before connecting them. Once the instrument and device have been connected, turn them back on.

IMPORTANT

The instrument may generate the maximum output voltage of approximately ± 12 V when the power is turned on or off, or in the event of an internal circuit malfunction. Make sure to connect to a device with the appropriate input voltage rating.

Output circuit

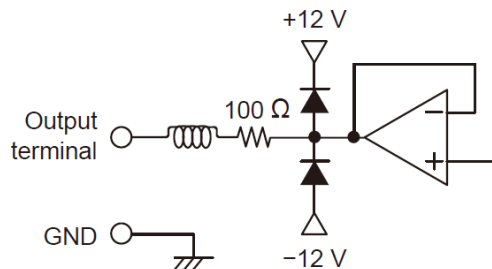

The output impedance of each output terminal is approximately 100 Ω .

When connecting a recorder, a DMM, or another device, use a model with high input impedance (1 M Ω or more).

See "Specifications of waveform and D/A output (optional)" (p.336)

Connector pin layout

The output of each pin can be set as desired.

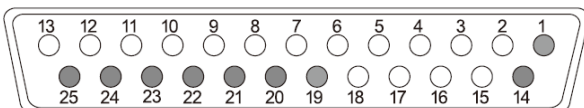

Pin No.	Output
1	GND
2	D/A1

Pin No.	Output
3	D/A2
4	D/A3
5	D/A4
6	D/A5
7	D/A6
8	D/A7
9	D/A8
10	D/A9
11	D/A10
12	D/A11
13	D/A12
14	GND
15	D/A13
16	D/A14
17	D/A15
18	D/A16
19	GND
20	GND
21	GND
22	GND
23	GND
24	GND
25	GND

How to connect

Use the connector included with the instrument (DB-25P-NR, DB19678-2R, Japan Aviation Electronics Industry) or equivalent part to make connections between the D/A output terminal and equipment according to the use. Be sure to use shielded cables.

- 1** Solder wires to the solder-type connector securely.
- 2** Fit the connector covers to the solder-type connector and secure the covers with the included screws (M2.6×6).
Secure the covers to prevent the connector from coming out.
Hold the covers when inserting and disconnecting the connector.
- 3** Connect the cable's shielding to the connector cover or cable bracket if it is not grounded.

8.2 Waveform/Analog Output (Waveform and D/A Output Option)

D/A output terminal (WAVEFORM & D/A OUTPUT)

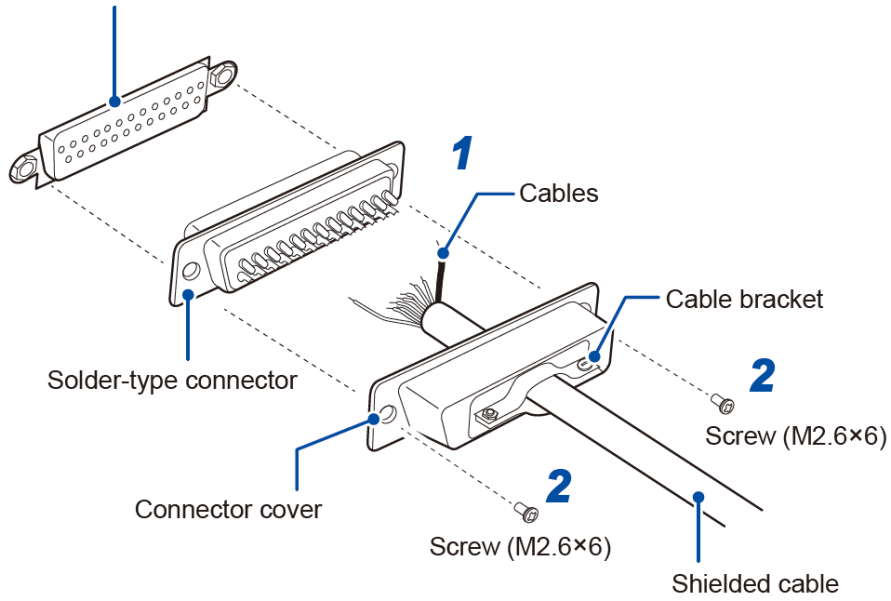

Rear panel of the instrument

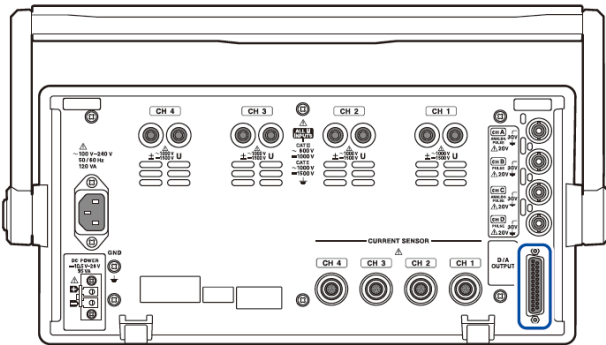

Selecting output parameters

Up to 16 output parameters can be selected for D/A output.

Display screen: **SYSTEM** key > **[OUTPUT]**



1 Choose between the two output types: **[Trend]** and **[Wave]** for each channel.

Trend	Analog output; Select from among the on-screen measured items (except the flicker measurement items).
Wave	Waveform output; Select waveforms to be outputted from the list.

(When outputting integrated values during analog output)

2 Tap the **[Integration f.s.]** box and then select the full scale value from the list.

1/10, 1/2, 1, 5, 10, 50, 100, 500, 1000, 5000, 10000

3 Tap the **[Waveform output range]** box and then set the output voltage value for full scale input during waveform output.

1 V f.s., 2 V f.s.

🔍 See “Waveform output” (p.246)

The instrument continuously outputs signals of selected items, regardless of whether it is on the Measurement, Input Settings, System Settings, or File Operation screen.

Analog output

- The instrument outputs measured values as level-converted DC voltage signals.
- Voltage input and current input (current sensor input) are isolated from each other.
- You can select an item from among the basic measurement items for each output channel; thus, 16 parameters in total can be outputted.
- By using the instrument in combination with a data logger or a recorder, you can record fluctuations over extended periods of time.

Specifications

Output voltage (Output range)	±5 V DC f.s. (valid output range: 1% f.s. to 110% f.s.) For the output rate of each parameter, see “Output rates” (p.248).
Output resistance	100 Ω ±5 Ω
Output update interval	Varies with the data update interval for the selected parameters.

8.2 Waveform/Analog Output (Waveform and D/A Output Option)

- The instrument will generate an output of approximately 6 V during positive over-range events (for voltage peak and current peak, approximately 5.3 V). For negative over-range events, the instrument will generate an output of approximately -6 V (for voltage peak and current peak, approximately -5.3 V).
- The instrument may generate a maximum output voltage of approximately ± 12 V in the event of a malfunction.
- When a VT ratio or CT ratio is used, the instrument will output the value obtained by multiplying the range by the VT ratio or CT ratio within the range of ± 5 V DC.
- While in the hold state or peak hold state, and during average operation, the instrument will output the appropriate operational value.
- When the hold function has been enabled and an interval time has been set, the instrument updates the output at set intervals once starting the integration.
- When the measurement range has been set to auto-ranging, the analog output rate will vary with range switching. In instances such as abruptly fluctuating measured values, exercise care to avoid making any mistakes in range conversion. In addition, it is recommended to fix the range manually during such measurement.
- Data cannot be output using the harmonic analysis function for parameters other than basic measurement items.
- Actually output measured values have an error of ± 1 ms from the data update interval setting.

Tips To change the full-scale value for active power integration D/A output

When using analog output, set the integration full-scale value.

For example, if the integrated value is small relative to the full-scale value, it will take a longer time for the integrated value to reach the full-scale value, causing the D/A output voltage to vary gradually.

Conversely, if the integrated value is large relative to the full-scale value, it will take a shorter time for the integrated value to reach the full-scale value, causing the D/A output voltage to vary abruptly.

By setting the integration full scale, you can change the active power integration D/A output full-scale value.

Waveform output

- The instrument will generate instantaneous waveforms for the input voltage and current.
- Voltage input and current input (current sensor input) are isolated from each other.
- The instrument can be used in combination with an oscilloscope or another device to observe input waveforms, such as equipment rush current.

Specifications

Output voltage (Output range)	Can choose between ± 1 V and ± 2 V Crest factor: 2.5 or greater
Output resistance	100 Ω ± 5 Ω
Output update interval	1 MHz (16-bit)

- It will take approximately 20 μ s (i.e., the delay time) from receiving a signal inputted in a voltage/current input terminal to output a signal from the D/A output connector.
- Waveforms are clipped at approximately ± 7 V.
- The instrument may generate a maximum output voltage of approximately ± 12 V in the event of a malfunction.

8.2 Waveform/Analog Output (Waveform and D/A Output Option)

- When a VT ratio or CT ratio is used, the instrument will output the voltage obtained by multiplying the range by the VT ratio or CT ratio.
- Waveform output consists of continuous instantaneous value output, without regard to hold, peak hold, or average operation.
- When the measurement range has been set to auto-ranging, the analog output rate will vary with range switching. In instances such as abruptly fluctuating measured values, exercise care to avoid making any mistakes in range conversion. In addition, it is recommended to fix the range during such measurement.

Output rates

Analog output is generated as a voltage of ± 5 V DC for a value of the full scale.

At full scale, the voltage listed in the following table will be output.

✓ : Has polarity

Selected output parameter	Notation	Output voltage polarity	Rated output voltage
Voltage RMS value	Urms		0 V to +5 V DC for a value of 0% to 100% of the range
RMS equivalent of voltage average rectified value	Umn		0 V to +5 V DC for a value of 0% to 100% of the range
Voltage AC component	Uac		0 V to +5 V DC for a value of 0% to 100% of the range
Voltage simple average	Udc	✓	± 5 V DC for a value of $\pm 100\%$ of the range
Voltage fundamental wave component	Ufnd		0 V to +5 V DC for a value of 0% to 100% of the range
Voltage waveform peak (+)	Upk+	✓	± 5 V DC for a value of $\pm 300\%$ of the range
Voltage waveform peak (-)	Upk-	✓	± 5 V DC for a value of $\pm 300\%$ of the range
Total voltage harmonic distortion	Uthd		0 V to +5 V DC for a value of 0% to 500%
Voltage ripple factor	Urf		0 V to +5 V DC for a value of 0% to 500%
Voltage unbalance rate	Uunb		0 V to +5 V DC for a value of 0% to 100%
Current RMS value	Irms		0 V to +5 V DC for a value of 0% to 100% of the range
RMS equivalent of average rectified current value	Imn		0 V to +5 V DC for a value of 0% to 100% of the range
Current AC component	Iac		0 V to +5 V DC for a value of 0% to 100% of the range
Current simple average	Idc	✓	± 5 V DC for a value of $\pm 100\%$ of the range
Current fundamental wave component	Ifnd		0 V to +5 V DC for a value of 0% to 100% of the range
Current waveform peak (+)	Ipk+	✓	± 5 V DC for a value of $\pm 300\%$ of the range
Current waveform peak (-)	Ipk-	✓	± 5 V DC for a value of $\pm 300\%$ of the range
Total harmonic current distortion	Ithd		0 V to +5 V DC for a value of 0% to 500%
Current ripple factor	Irf		0 V to +5 V DC for a value of 0% to 500%
Current unbalance rate	Iunb		0 V to +5 V DC for a value of 0% to 100%

8.2 Waveform/Analog Output (Waveform and D/A Output Option)

Selected output parameter	Notation	Output voltage polarity	Rated output voltage
Active power	P	✓	P1, P2, P3, P4: (Voltage range) × (Current range) P12, P23, P34: (Voltage range) × (Current range) × 2 P123, P234 of 3V3A, 3P3W3M: (Voltage range) × (Current range) × 2 P123, P234 of 3P4W: (Voltage range) × (Current range) × 3 Example: For 3P4W, P123, 300 V range, 10 A range 300 V × 10 A × 3 = 9 kW (Thus, the full scale is calculated.) ±5 V DC for a value of ±9 kW f.s.
Fundamental wave active power	Pfnd	✓	Same as active power (P)
Apparent power	S		S1, S2, S3, S4: (Voltage range) × (Current range) S12, S23, P34: (Voltage range) × (Current range) × 2 S123, S234 of 3V3A, 3P3W3M: (Voltage range) × (Current range) × 2 S123, S234 of 3P4W: (Voltage range) × (Current range) × 3 Example: For S34, 150 V range, 10 A range 150 V × 10 A × 2 = 3 kW (Thus, the full scale is calculated.) 0 V to +5 V DC for a value of 0 to 3 kW f.s.
Fundamental wave apparent power	Sfnd		Same as apparent power (S)
Reactive power	Q	✓	Same as active power (P)
Fundamental wave reactive power	Qfnd	✓	Same as active power (P)
Power factor	λ	✓	±5 V DC for a power factor of ±1
Fundamental wave power factor	λfnd	✓	±5 V DC for a fundamental wave power factor of ±1
Voltage phase angle	θU	✓	±5 V DC for a voltage phase angle of ±180°
Current phase angle	θI	✓	Same as voltage phase angle (θU)
Power phase angle	∅	✓	Same as voltage phase angle (θU)
Voltage frequency, current frequency	fU, fI		+5 V DC for the upper frequency limit setting
Integrated positive current value	Ih+		Same as sum of positive and negative current values (Ih)
Integrated negative current value	Ih-	*4	Same as sum of positive and negative current values (Ih)
Sum of positive and negative current values	Ih		(Current range) × (Integration full scale) Example: If integrating for 1 h with the 10 A range, the current integration full scale is determined to be 10 Ah.*2 ±5 V DC for a value of ±10 Ah
Integrated positive power value	WP+		Same as sum of positive and negative power values (WP)

8.2 Waveform/Analog Output (Waveform and D/A Output Option)

Selected output parameter	Notation	Output voltage polarity	Rated output voltage
Integrated negative power value	WP-	*4	Same as sum of positive and negative power values (WP)
Sum of integrated positive and negative power values	WP	✓	<p>WP1, WP2, WP3, WP4: (Voltage range) × (Current range) × (Integration full scale)</p> <p>WP12, WP23, WP34: (Voltage range) × (Current range) × (Integration full scale) × 2</p> <p>WP123, WP234 of 3V3A, 3P3W3M: (Voltage range) × (Current range) × (Integration full scale) × 2</p> <p>WP123, WP234 of 3P4W: (Voltage range) × (Current range) × (Integration full scale) × 3</p> <p>Example: If integrating the power value for 1 hour with the 300 V range and the 10 A range for WP123, the integrated active power full scale is determined to be 9 kWh. ±5 V DC for a value of ±9 kWh</p>
Efficiency	η		0 V to +5 V DC for a value of 0% to 200%
Loss value	Loss	✓	<p>Pin = Pin1 + Pin2 + Pin3 + Pin4 + Pin5 + Pin6, Pout = Pout1 + Pout2 + Pout3 + Pout4 + Pout5 + Pout6</p> <p>The larger of Pin and Pout is used as the P range. ±5 V DC for a value of ±100% of the P range</p> <p>Example: With the 3 kW P range, ±5 V DC for a value of ±100% of 3 kW</p>
Torque	Tq	✓	<p>Analog DC input: (Voltage range) × (Scale value) = (Rated torque)</p> <p>±5 V DC for a value of ±100% of the rated torque</p> <p>Frequency input: (Scale value) = (Rated torque)</p> <p>±5 V DC for a value of ±100% of the rated torque</p>
RPM	Spd	✓	<p>Analog DC input: (Voltage range) × (Scale value) = (Rated RPM)</p> <p>Pulse input: $[60 \times (\text{Upper frequency limit})] / (\text{Pulse count setting}) = (\text{Rated RPM})$</p> <p>±5 V DC for a value of ±100% of the rated RPM</p>
Motor power	Pm	✓	±5 V DC for a value of ±100% of the Pm range*3
Slip	Slip	✓	± 5 V DC for a value of ±100%
Free input during independent input mode operation	CH*	✓	<p>Analog DC input: ±5 V DC for a value of ±100% of the voltage range</p> <p>Pulse input: ±5 V DC for a value of ±100% of the upper frequency limit</p>
User-defined formula	UDF	✓	±5 V DC for a value of ±100% of the maximum value set for each user-defined formula

*1 Analog DC input has polarity, but pulse frequency input does not.

*2 If the voltage for the integrated value exceeds ±5 V, analog output will switch to 0 V before continuing to vary again.

*3 The Pm range is calculated by substituting the rated torque and rated RPM respectively for the torque and RPM of the motor power equation.

*4 Value always has a negative sign.

Examples of D/A output

Voltage/current (dc), active power, reactive power

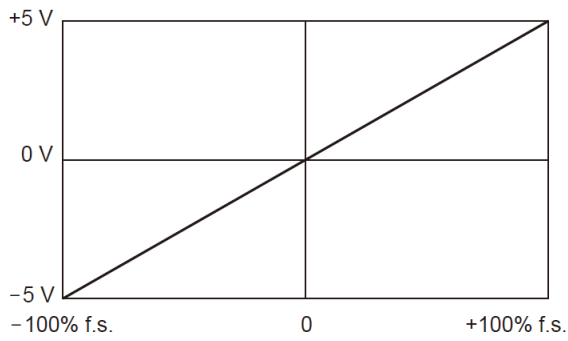

Voltage/current (rms, mn, ac, fnd, unb), apparent power

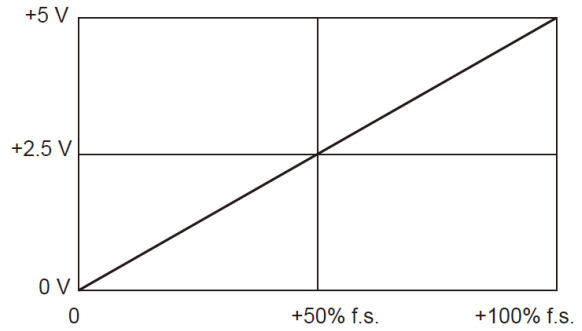

Power factor

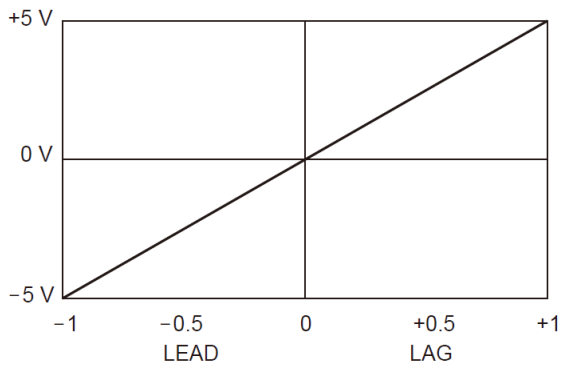

Voltage, current, power phase angle

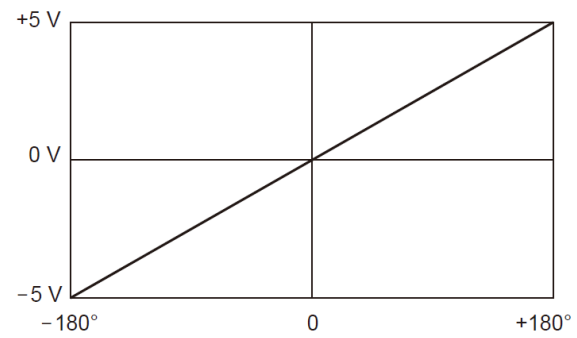

Frequency

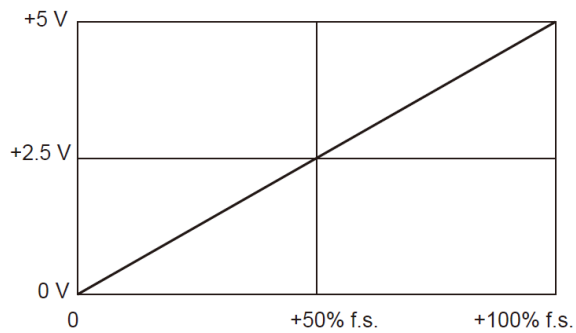

The upper frequency limit setting is used as 100% f.s.

Integrated current, integrated power

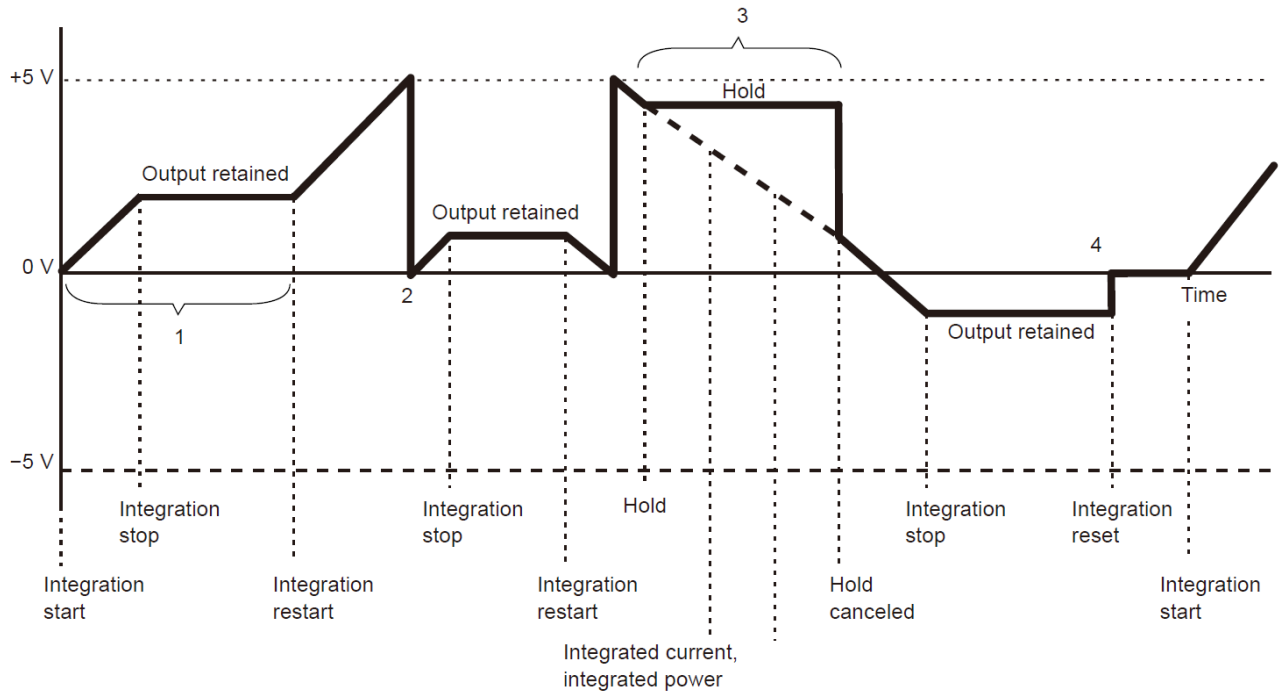

1. Analog output varies with the start of integration. Analog output is retained when integration stops.
2. If the voltage for the integrated value exceeds ± 5 V, analog output will switch to 0 V before continuing to vary again.
3. Analog output is retained when the display is frozen during integration. When the hold operation is canceled, analog output will vary based on the original integrated value.
4. When the integrated value is reset, analog output will switch to 0 V.

8.3 Controlling Integration with External Signals

Integration can be started and stopped, and integration data can be reset with 2-level (0 to 5 V) logic signals or by shorting/opening contact signals of the instrument's external control interface.

CAUTION





■ **Use Hioki-specified cables. Alternatively, use cables that provide sufficient withstand voltage and current capacity.**

Failure to follow this guidance could result in damage to the instrument.

Cable connections

Tools to be prepared

<input type="checkbox"/> Cables	
<input type="checkbox"/> Flat-head screwdriver <ul style="list-style-type: none"> • Shaft diameter: $\varnothing 3$ mm • Blade width: 2.6 mm 	

Applicable wire

Single wire: $\varnothing 0.65$ mm (AWG22)

Stranded wire: 0.32 mm² (AWG22)

Stranded wire diameter: $\varnothing 0.12$ mm or more

Usable wires

Single wire: $\varnothing 0.32$ mm to $\varnothing 0.65$ mm (AWG28 to AWG22)

Stranded wire: 0.08 mm² to 0.32 mm² (AWG28 to AWG22)

Stranded wire diameter: $\varnothing 0.12$ mm or more

Standard bare wire length: 9 mm to 10 mm

How to connect cables

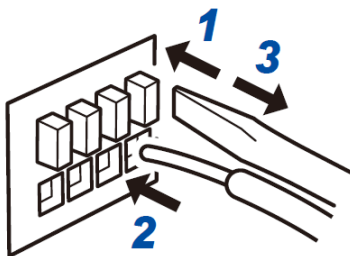

- 1** Press in the terminal buttons using a tool such as a flat-head screwdriver.
- 2** With the button pressed in, insert the cable into the cable connection hole.
- 3** Release the button.
This locks the cable in.

Device for controlling this instrument

Prepare a device and the cable so that the functions are assigned to the pins listed below.

Pin No.	Function
1	GND
2	Resetting integrated values When this pin's level has been low for at least 200 ms, integrated values will be reset. This function is valid only while integration is stopped.
3	Hold When this pin's level changes from high (5 V or open) to low (0 V or shorted), the display will be held. When it changes from low to high, the hold will be canceled.
4	Starting/stopping the integration When this pin's level changes from high (5 V or open) to low (0 V or shorted), integration will start. When it changes from low to high, integration will stop.

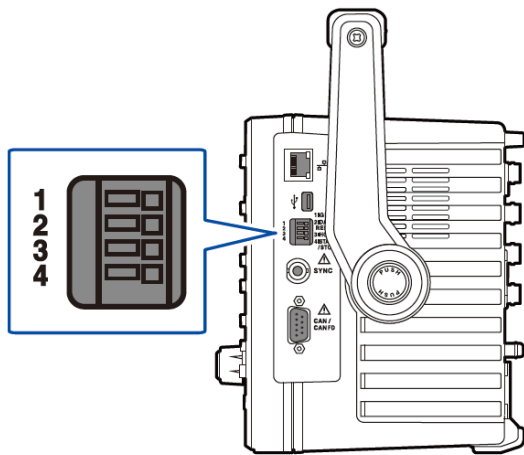

Internal circuit diagram of each external control terminal

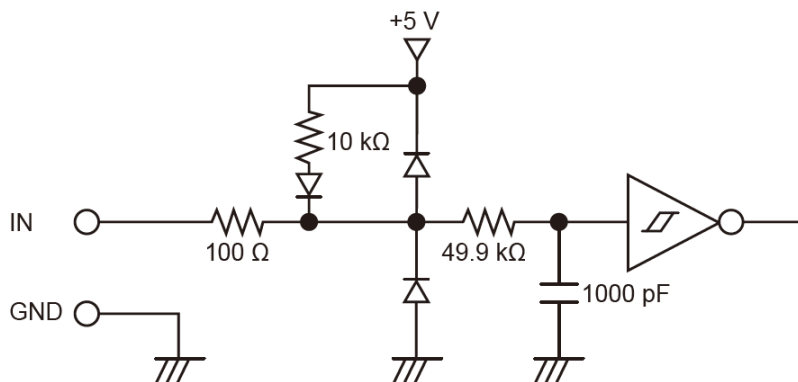

Control signal timing

External control interface signals are detected during the intervals shown on the timing chart below. Updating on-screen information may delay depending on the frequency being measured and the synchronization state between the instrument and external device.

Starting/stopping the integration

Using this signal can start/stop integration.

This operation is the same as that performed by the **START/STOP** key on the instrument's panel.

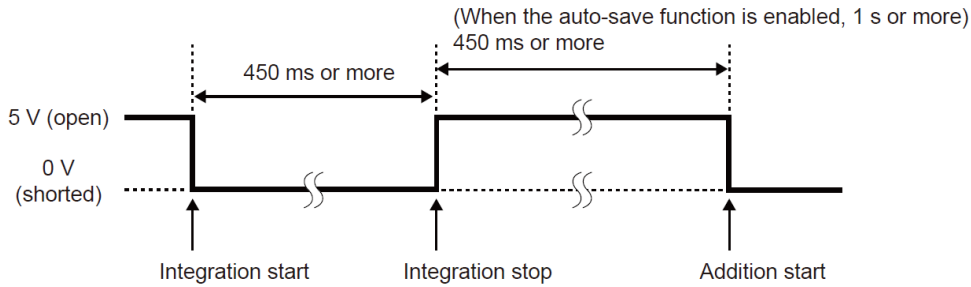

Resetting integrated values

Using this signal can reset integrated values to zero.

This operation is the same as that performed by the **DATA RESET** key on the instrument's panel.

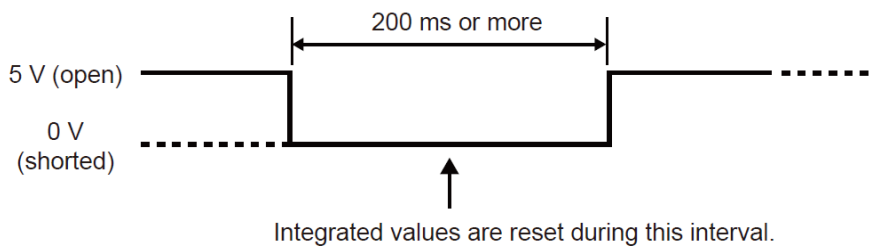

This signal is ignored while integration is being performed.

Input this signal at least 450 ms (or at least 1 s when the auto-save operation is enabled) after integration stops.

Hold

This operation is the same as that performed by the **HOLD** key on the instrument's panel.

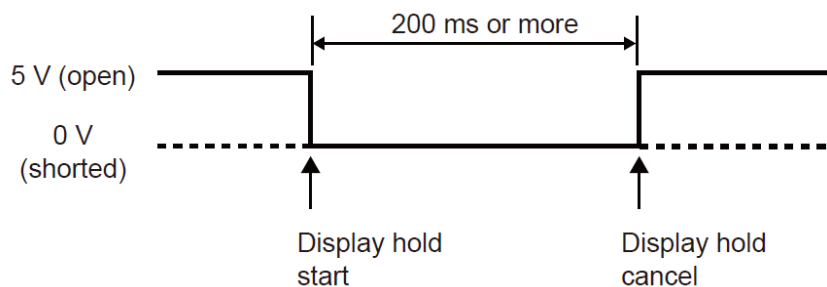

To avoid instrument damage, do not input a signal at a voltage of 5.5 V or more. Use chatter-free control signals.

8.4 CAN output function

Overview of the CAN output function

What is a CAN?

A CAN, which stands for controller area network, is a serial communication protocol established as a standard by the International Organization for Standardization (ISO).

Using this communication protocol, the instrument's CAN output function can output measured data on a CAN bus in real time so that it can be recorded together with data from electronic control units (ECUs).

Consolidating data on a CAN logger enables data to be centralized without degrading accuracy, resulting in a comprehensive evaluation.

CAN data output procedure

1 Prepare for measurement.

🔍 See "2 Preparing for measurement" (p.51)

2 Configure CAN output settings.

🔍 See "Setting CAN output" (p.257)

Setting a destination device

Create the DBC file.

🔍 See "Creating a DBC file" (p.262)

Load the DBC file in the destination device.

3 Wire the CAN bus.

4 Perform CAN output.

🔍 See "Outputting CAN signals" (p.264)

Setting CAN output

Setting CAN communications

To enable the instrument to communicate correctly with a device to which CAN signals are sent, set the CAN protocol setting, the communication speed, and the terminator resistor.

Display screen: **SYSTEM** key > **[CAN]**



1 Tap the **[Use]** box to select ON or OFF.

ON	Enable CAN communication
OFF	Disable CAN communication

Set to ON when communicating with the CAN bus. When not communicating with the CAN bus, you should turn it OFF to prevent the unintentional transmission of error frames.

8.4 CAN output function

- 2 Tap the **[Mode]** box and select the CAN protocol from the list.

CAN	CAN mode
CAN FD (ISO)	CAN FD mode (in conformity with ISO 11898-1:2015)
CAN FD (nonISO)	CAN FD mode (not in conformity with ISO)

When the CAN protocol is changed, the settings of the CAN output parameters, described below, are initialized.

- 3 When CAN mode is selected

Tap the **[Communication speed]** box and select the communication speed from the list.

125 kbps, 250 kbps, 500 kbps, 1 Mbps

When CAN FD mode is selected

Tap the **[Arbitration speed]** box and select the communication speed.

500 kbps, 1 Mbps

Tap the **[Data speed]** box and select the communication speed.

500 kbps, 1 Mbps, 2 Mbps, 4 Mbps

- 4 Tap the **[Sampling point]** box and set the sampling point using the numeric keypad.

0.0% to 99.9%

- 5 Tap **[Other settings]**.

The **[Other settings]** window will be displayed.

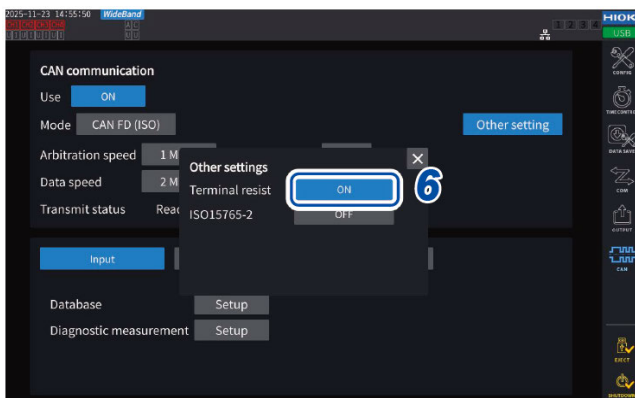

- 6 Tap the **[Terminal resist]** box to set it to ON or OFF.

ON	Use a terminator resistor.
OFF	Do not use a terminator resistor.

Setting the CAN database

Set CAN signals output from the instrument.

Display screen: **SYSTEM** key > **[CAN]**

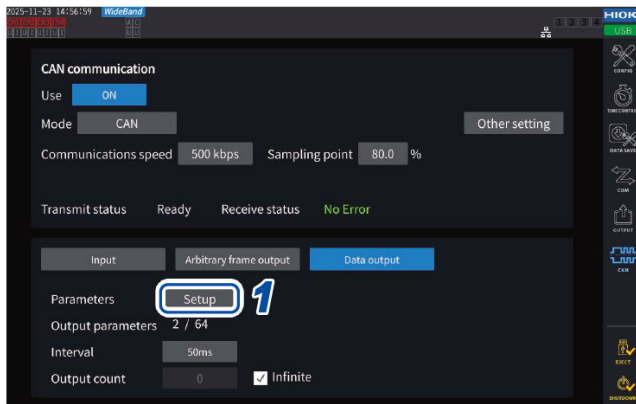

- 1 Tap **[Setup]** in the **[Parameters]** box
The setting window will be displayed.

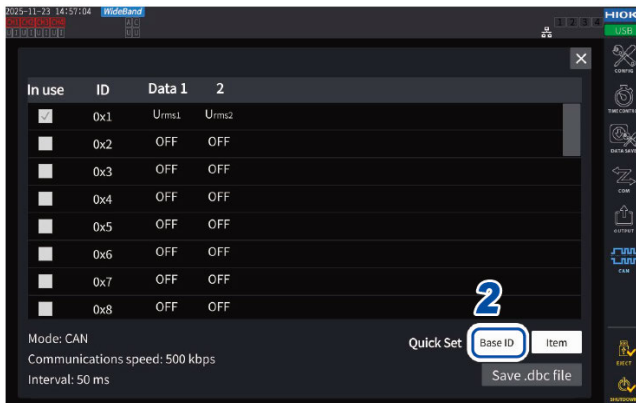

- 2 Tap **[Base ID]** in the **[Quick Set]** box
You can collectively set the IDs of CAN signals.

8.4 CAN output function

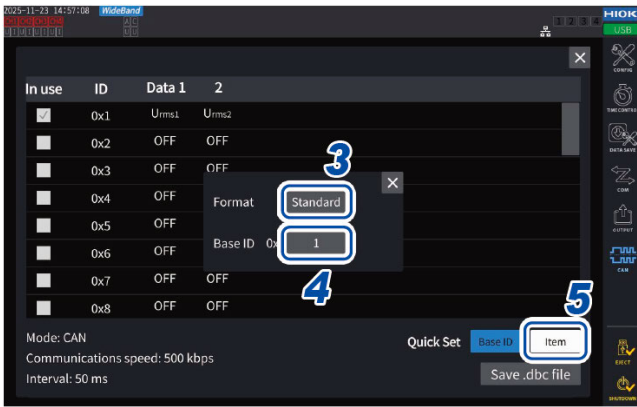

- Tap the **[Format]** box and select a format from the list.

Standard	Use a standard format.
Extension	Use an extended format.

- Tap the **[Base ID]** box and set a reference ID using the numeric keypad.

When **[Standard]** is selected

0 to 7FF (enter in hexadecimal)

When **[Extension]** is selected

0 to 1FFFFFFF (enter in hexadecimal)

The output CAN signals' IDs are added by one based on the set ID.

Set the IDs of the CAN signals transmitted over the CAN buses used for communications so that they are unique.

- Tap **[Item]**.

The setting window will be displayed.

- Select the measured data to output.

- Tap **[Apply and save .dbc file]**.

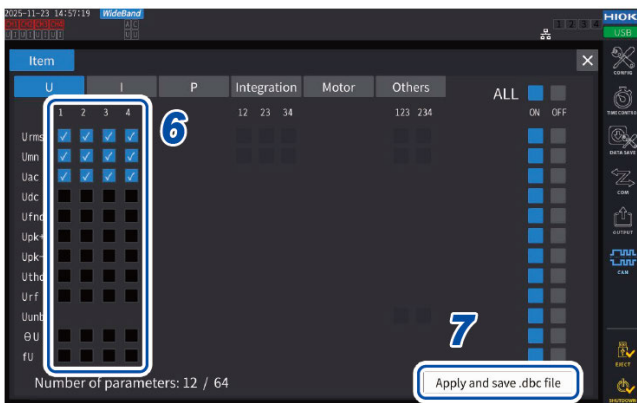

- Set a filename using a keyboard.

Saves to a USB flash drive or the internal memory.

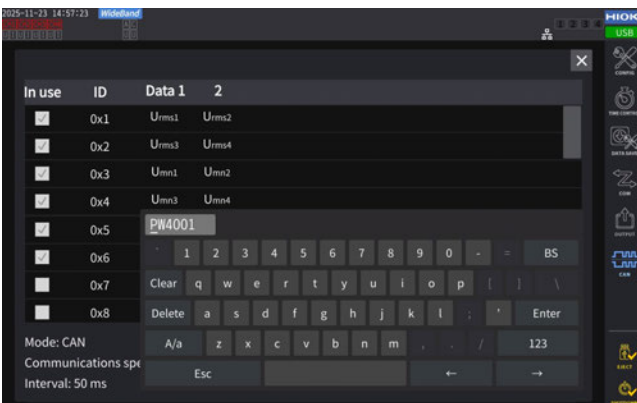

Selectable measurement data types

Basic measurement items	Data measured with the instrument (except the flicker measurement items)
Time (Select on the Others tab)	The time elapsed after CAN output has been started is divided into hours, minutes, seconds, and milliseconds before being output.
Count (Select on the Others tab)	Outputs the number of times the signals were output after CAN output started.

Number of selectable measurement data sets

The number of selectable measurement data sets is determined by the settings of the CAN protocol, communication speed, and output interval. If you want to change the number of selectable sets, change the settings of the CAN protocol, communication speed, and output interval.

CAN protocol	Communications speed	Number of selectable data sets		
		1 ms interval setting	10 ms interval setting	50 ms interval setting
CAN	125 kbps	0	4	20
	250 kbps	0	8	40
	500 kbps	2	16	64 (maximum number)
	1 Mbps	4	32	64 (maximum number)
CAN FD	□ - 500 kbps	0	32	160
	□ - 1 Mbps	0	64	320 (all selectable parameters)
	□ - 2 Mbps	16* ¹	128	512 (all selectable parameters)
	□ - 4 Mbps	16	256 (all selectable parameters)	512 (all selectable parameters)

- The number with a 100 ms interval becomes twice as many as that with a 50 ms interval, and that with a 200 ms interval becomes four times as many as that with a 50 ms interval.
- The number of CAN FD data sets that can be output depends only on the communication speed in the data area. It does not change with the communication speed in the arbitration field.
- The □ characters in the table indicate any numerical values.

*1 When the CAN FD communications speed is □ - 2 Mbps and the set interval is 1 ms, the signal will not be resent if the CAN output is not received normally.

Creating a DBC file

After setting the CAN output parameters, you can move to the DBC file creation screen. You can also move to the DBC file creation window by tapping **[Save .dbc file]**.

Display screen: **SYSTEM** key > **[CAN]**

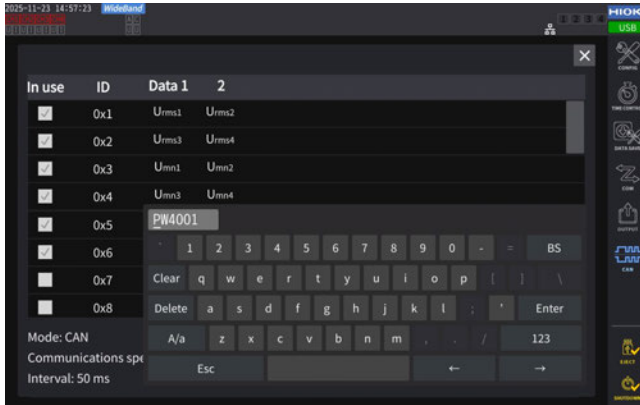

- 1 Tap **[Save .dbc file]**.
- 2 Set a filename using a keyboard.
(Up to 8 alphanumeric characters and symbols)

Save destination	USB flash drive, internal memory
Filename	Enter as desired (up to 8 characters), with DBC extension Example: PW4001.DBC
Remark	Files are saved in the folder specified as the save destination in the manual save settings. See "Manually saving measured data" (p.210)

Tips What is a DBC file?

A DBC file contains the definitions of the CAN database needed to decode output CAN signals by the destination device.

Use this file as the CAN definitions for the device to which the CAN signals are sent.

DBC files are created based on the present of the CAN database settings. Thus, always set the CAN database before creating a DBC file; if you change the CAN database, recreate a DBC file each time.

Setting CAN output

Set a method to output CAN signals from the instrument.

Display screen: **SYSTEM** key > **[CAN]**

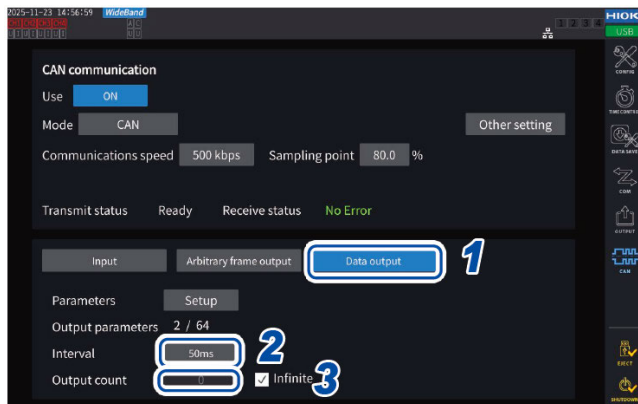

1 Tap **[Data output]**.

2 Tap the **[Interval]** box and select a CAN-signal-outputting interval from the list.

(For the data update interval of 1 ms)

1 ms, 10 ms, 50 ms, 100 ms, 200 ms, 500 ms, 1 s, 5 s, 10 s, 15 s, 30 s, 1 min, 5 min, 10 min, 15 min, 30 min, 60 min

(For the data update interval of 10 ms)

10 ms, 50 ms, 100 ms, 200 ms, 500 ms, 1 s, 5 s, 10 s, 15 s, 30 s, 1 min, 5 min, 10 min, 15 min, 30 min, 60 min

(For the data update interval of 50 ms)

50 ms, 100 ms, 200 ms, 500 ms, 1 s, 5 s, 10 s, 15 s, 30 s, 1 min, 5 min, 10 min, 15 min, 30 min, 60 min

(For the data update interval of 200 ms)

200 ms, 1 s, 5 s, 10 s, 15 s, 30 s, 1 min, 5 min, 10 min, 15 min, 30 min, 60 min

(For IEC measurement mode)

100 ms, 200 ms, 500 ms, 1 s, 5 s, 10 s, 15 s, 30 s, 1 min, 5 min, 10 min, 15 min, 30 min, 60 min

The actual data update intervals have an error of ± 1 ms from the data update interval setting. If you need to acquire data at set update intervals, select the **Time** data output.

3 Tap the **[Output count]** box and select the number of times the CAN signals are output using the numeric keypad.

When the **[Infinite]** check box is selected, the CAN signals are output infinitely many times.

If the check box is cleared, the number of times the CAN signals are output can be set as desired.

0 to 10000 (0: infinite)

Outputting CAN signals

Complete the following procedure before outputting the CAN signals from the instrument.

1 Load the created DBC file to the device to which the CAN signals are sent.

 See "Creating a DBC file" (p.262)

2 Connect the instrument to the CAN-signal destination device using a CAN bus.

Start

Press the **START/STOP** key to output CAN signals.

- Integration starts in conjunction with CAN-signal output.
- The setting cannot be changed until the integration is reset.

Stop

CAN output is stopped by either of the following measures:

- Press the **START/STOP** key again.
- CAN signals have been output the set number of times.

Integration stops in conjunction with CAN-signal output stop.

Over value and error value in the output data

Measurement data output from the instrument is replaced with an over value or an error value in the following circumstances.

Over value +99999.9E+30	Indicates the maximum displayable value corresponding to the presently set range has been exceeded.
Error value +77777.7E+30	Indicates calculation was impossible because it was attempted immediately after the setting changed.

Checking the output status

The output status can be checked with the **[Transmit status]** field.

None	The CAN interface is stopped.
SetupError	CAN interface startup failed.
Ready	The CAN interface is booting. Press the START/STOP key to start to output the CAN signals.
OK	The CAN signals are outputting normally.
Warning	A CAN output error occurred most recently.
Send error	The CAN output has an anomaly.
Bus OFF	The instrument has been disconnected from the CAN bus due to a CAN error.

Tips If the CAN output status does not become OK

Check the following items.

- The instrument is properly connected to the CAN bus.
- The device to which the CAN signals are sent is properly connected.
- The terminator resistor is positioned properly.
- The CAN communications have been set properly.
- The CAN protocol, communications speed, and sampling point settings are the same as those of the device to which the instrument connects.

If the output CAN signal data shows an abnormal value

Check the following items.

- The instrument's CAN database settings have not been changed after creating the DBC file.
- If another device sent a CAN signal, its ID number is unique.

8.5 Arbitrary Frame Output Function

The instrument's arbitrary frame output function enables the outputting of CAN signals containing arbitrary data to the connected CAN bus. For some CAN communications, a CAN frame called a "query" must be sent in order to obtain the CAN data. Using this function enables support for CAN input.

When using the arbitrary frame output function, set the data update interval to a value other than 1 ms. It cannot be used with 1 ms.

Arbitrary frame output settings

Display screen: **SYSTEM** key > **[CAN]**

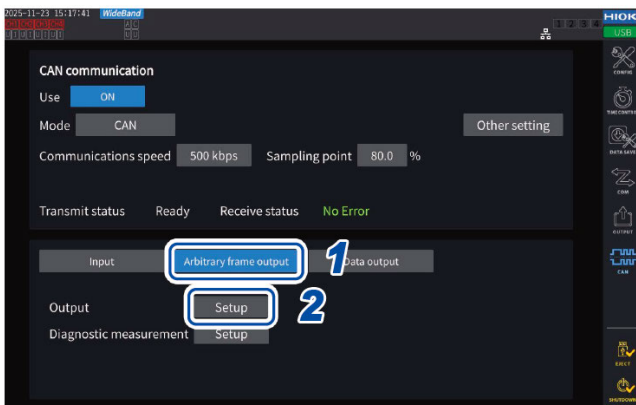

1 Tap the **[Arbitrary frame output]** tab.

2 Tap **[Setup]** in the **[Output]** box.

The arbitrary frame output settings window will be displayed.

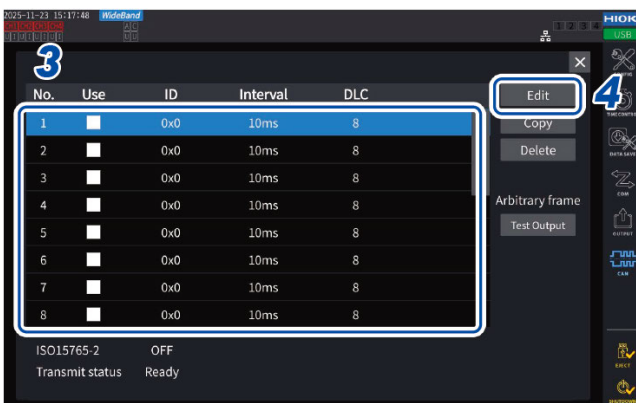

3 Select a number from No. 1 to No. 20.

Up to 20 types of arbitrary frames can be output.

4 Tap **[Edit]**.

The advanced arbitrary frame output settings window will be displayed.

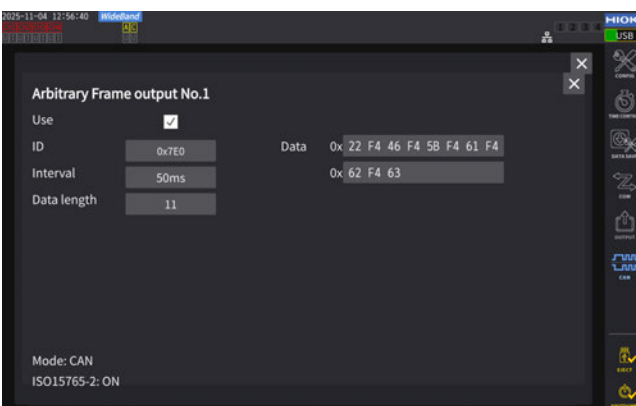

5 Configure each of the advanced arbitrary frame output settings.

Advanced arbitrary frame output settings

Item	Available selections	Description
Use	Checked/Not checked	Select whether to output arbitrary frames.
ID		
Format	Standard/Extension	Select the format of the CAN frame(s) to be output.
ID	When [Standard] is selected 0 to 7FF (enter in hexadecimal) When [Extension] is selected 0 to 1FFFFFFF (enter in hexadecimal)	Select the ID of the CAN frame(s) to be output.
Interval	10ms/50ms/200ms/START/STOP	Select the output interval of the CAN frame(s). START or STOP is output when integration starts or stops.
DLC (When ISO15765-2 is turned off*1)	When [CAN] is selected 0, 1, 2, 3, 4, 5, 6, 7, 8 When [CAN FD (ISO/nonISO)] is selected 0, 1, 2, 3, 4, 5, 6, 7, 8, 12, 16, 20, 24, 32, 48, 64	Select the number of data bytes of the CAN frame(s).
Data length (When ISO15765-2 is turned on*1)	0 to 41	Select the number of data bytes of the CAN frame(s).
Data	00 to FF (enter in hexadecimal)	Select the CAN frame data.

*1 For ISO15765-2 settings, see “8.6 CAN Input Function” (p.269).

Copying advanced arbitrary frame output settings



- 1** Tap **[Copy]** while the No. of the advanced arbitrary frame output setting to be copied is highlighted.
The window for selecting a copy destination will appear.
- 2** Select the copy destination.
- 3** Tap **[OK]**.

Deleting advanced arbitrary frame output settings

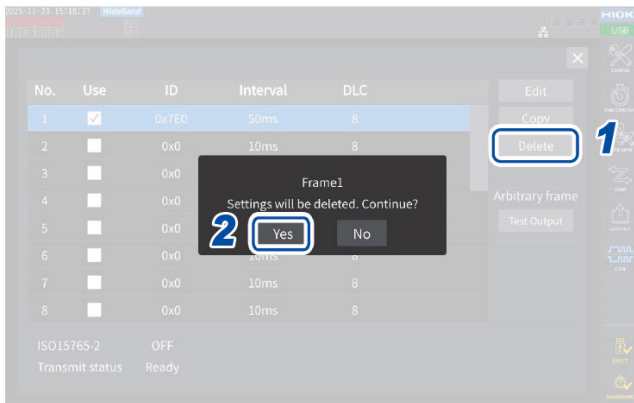

1 Tap **[Delete]** while the No. of the advanced arbitrary frame output setting to be deleted is highlighted.

The deletion window will appear.

2 Tap **[Yes]**.

Checking arbitrary frame settings (when already connected to the CAN bus)

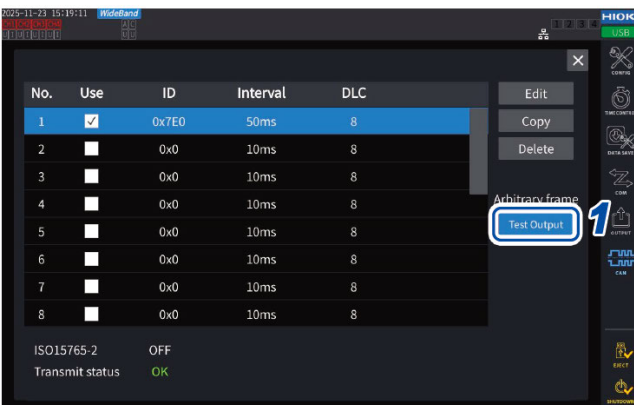

1 Tap **[Test Output]**.

The arbitrary frame(s) will be output.

If the output arbitrary frame(s) were properly received, **[OK]** will be shown next to **[Transmit status]**. If **[Send Error]** is shown next to **[Transmit status]**, the CAN communication settings must be revised. Output will stop once the arbitrary frame output settings window is closed.

Outputting arbitrary frames

Start

Press the **START/STOP** key to start outputting arbitrary frames.

- Integration starts in conjunction with arbitrary frame output.
- The setting cannot be changed until the integration is reset.
- When the interval is 10 ms, 50 ms, or 200 ms, frames are output at the specified period.
- When the interval is START, one frame is output at the start of integration.

Stop

Press the **START/STOP** key to stop outputting arbitrary frames.

- When the interval is STOP, one frame is output at the stop of integration.
- Integration stops in conjunction with CAN-signal output stop.

8.6 CAN Input Function

Overview of the CAN input function

The instrument's CAN input function can acquire CAN signals transmitted over the CAN bus in real time, convert them into data by referencing the CAN database, and record them on the instrument. It also enables comprehensive analysis by centralizing the data measured by the sensors and the data acquired from the CAN bus.

When the data update interval is set to 1 ms, [-----] is always displayed as the CAN input value. When using the CAN input function, set the data update interval to a value other than 1 ms.

If no CAN signal matching the CAN input database conditions is obtained during a single data update, the previous CAN input value will be retained. If two or more CAN signals matching the same CAN input database conditions are obtained, the latest data will be reflected in the CAN input value.

CAN data input procedure

1 Configure CAN input settings.

🔍 See “CAN input settings” (p.269)

To configure using the CAN editor, see the “CAN Editor Instruction Manual.”

If necessary, also refer to:

🔍 See “Arbitrary frame output settings” (p.266)

2 Wire the CAN bus.

3 Perform CAN input.

🔍 See “Outputting arbitrary frames (when arbitrary frame output settings are already configured)” (p.274)

CAN input settings

Setting CAN communications

To enable the instrument to communicate correctly with a device to which CAN signals are sent, set the CAN protocol setting, the communication speed, and the terminator resistor.

Display screen: **SYSTEM** key > [CAN]



1 Tap the [Use] box to select ON or OFF.

ON	Enable CAN communication
OFF	Disable CAN communication

Set to ON when communicating with the CAN bus. When not communicating with the CAN bus, you should turn it OFF to prevent the unintentional transmission of error frames.

8.6 CAN Input Function

- 2 Tap the **[Mode]** box and select the CAN protocol from the list.

CAN	CAN mode
CAN FD (ISO)	CAN FD mode (in conformity with ISO 11898-1:2015)
CAN FD (nonISO)	CAN FD mode (not in conformity with ISO)

When the CAN protocol is changed, the settings of the CAN output parameters are initialized.

- 3 When CAN mode is selected

Tap the **[Communication speed]** box and select the communication speed from the list.

125 kbps, 250 kbps, 500 kbps, 1 Mbps

When CAN FD mode is selected

Tap the **[Arbitration speed]** box and select the communication speed.

500 kbps, 1 Mbps

Tap the **[Data speed]** box and select the communication speed.

500 kbps, 1 Mbps, 2 Mbps, 4 Mbps

- 4 Tap the **[Sampling point]** box and set the sampling point using the numeric keypad.

0.0% to 99.9%

- 5 Tap **[Other settings]**.

The **[Other settings]** window will be displayed.

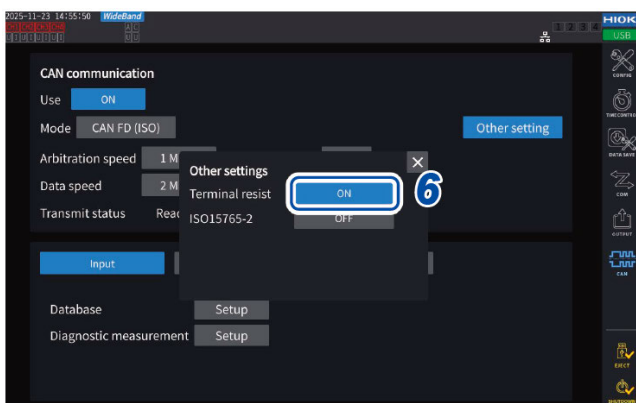

- 6 Tap the **[Terminal resist]** box to set it to ON or OFF.

ON	Use a terminator resistor.
OFF	Do not use a terminator resistor.

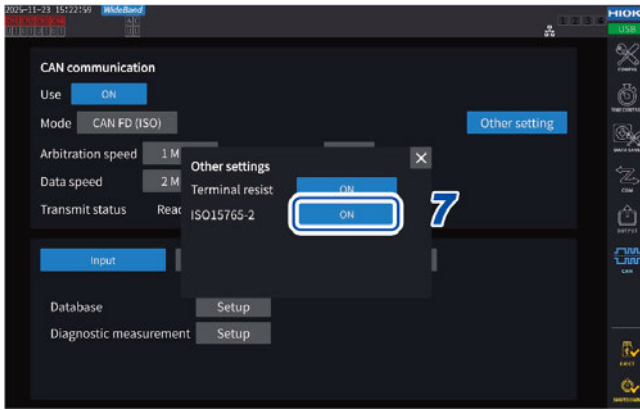

7 Tap the **[ISO15765-2]** box to select ON or OFF.

ON	CAN measurements are performed in accordance with the ISO15765-2 standard.
OFF	CAN measurements are not performed in accordance with the ISO15765-2 standard.

ISO15765-2 is a standard for dividing long messages into multiple frames for transmission. It is typically used to communicate with OBD-II equipped vehicles.

8.6 CAN Input Function

CAN input database settings

Configure analysis parameters for the CAN signals input to the instrument.

Display screen: **SYSTEM** key > **[CAN]**

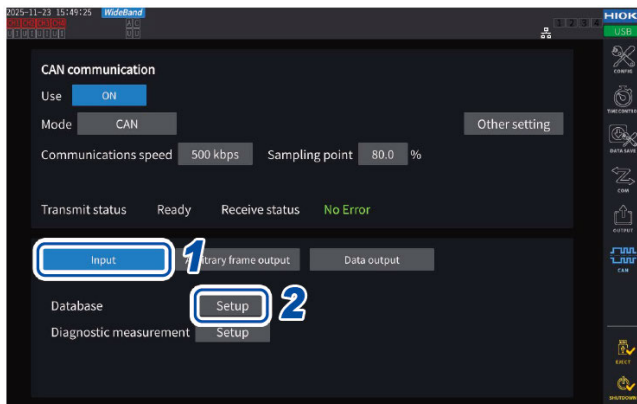

1 Tap **[Input]**.

2 Tap **[Setup]** in the **[Database]** box.

The settings window for the CAN input database will appear.

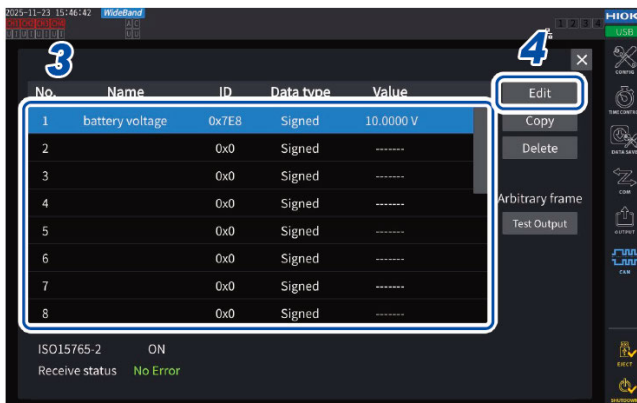

3 Select a number from No. 1 to No. 20.

No. 1 to No. 20 correspond to the measurement parameters for CAN1 to CAN20.

Up to 20 CAN input items can be selected.

4 Tap **[Edit]**.

The advanced CAN input settings window will appear.

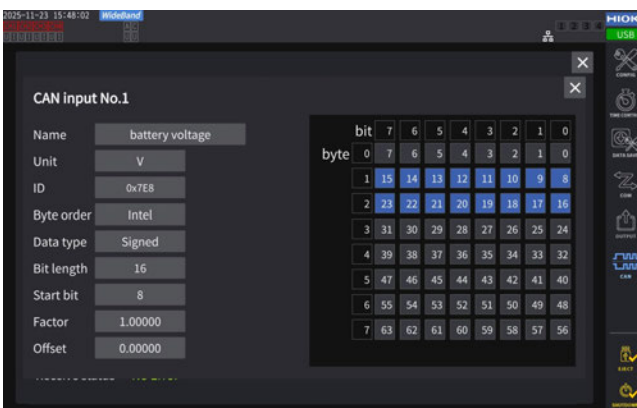

5 Configure each of the advanced CAN input settings.

Advanced CAN input settings

Item	Available selections	Description
Name	Up to 40 one-byte character strings Example: Speed	Enter a name for the CAN signal to be analyzed.
Unit	Up to 8 one-byte character strings Example: km/h	Select the unit for the CAN signal.
ID		

Item	Available selections	Description
Format	Standard/Extension	Select the CAN frame format.
ID	When [Standard] is selected 0 to 7FF (enter in hexadecimal) When [Extension] is selected 0 to 1FFFFFFF (enter in hexadecimal)	Input the ID of the CAN frame that contains the CAN signal to be analyzed.
Byte order	Little endian (Intel)/Big endian (Motorola)	Select the byte order of the CAN signal.
Data type	Unsigned/Signed/Float/Double	Select the data type for converting the CAN signal to a numerical value.
Bit length	1 to 64	Set the bit length of the CAN signal. Fixed as 32 when Float is selected as the data type or as 64 when Double is selected.
Start bit	0 to 5119	Set the data start bit position of the CAN signal.
Factor	Enter the value using the numeric keypad window.	Set the factor value for converting the CAN signal to a numerical value.
Offset	Enter the value using the numeric keypad window.	Set the offset value for converting the CAN signal to a numerical value.

The bit positions of the CAN signals to be analyzed are displayed on the right side of the window based on the advanced CAN input settings for the byte order, bit length, and start bit. Bit positions are highlighted in blue if there are no errors in the settings, and in red if there are errors.

Copying advanced CAN input settings

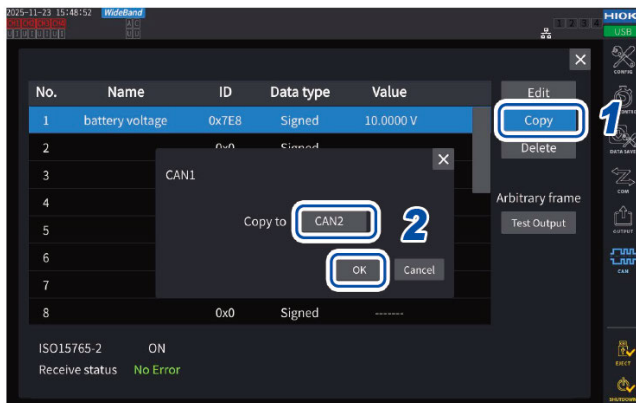

- 1 Tap **[Copy]** while the No. of the advanced CAN input setting to be copied is highlighted.
- 2 Select the copy destination in the copy window and tap **[OK]**.

Deleting advanced CAN input settings

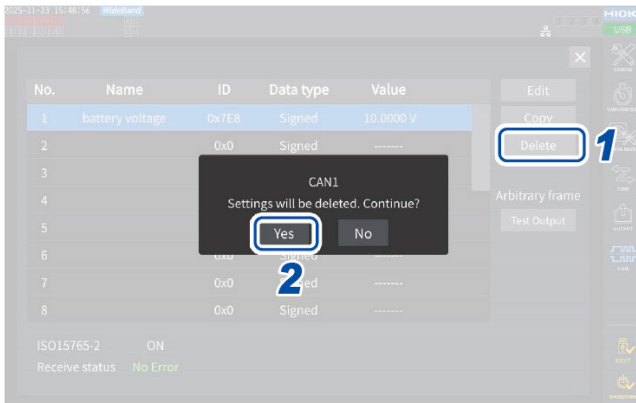

- 1 Tap **[Delete]** while the No. of the advanced CAN input setting to be deleted is highlighted. The deletion window will appear.
- 2 Tap **[Yes]**.

Outputting arbitrary frames (when arbitrary frame output settings are already configured)

If a query is required for the CAN signal request, the item(s) being queried must be set in an arbitrary frame and sent to the object under measurement. This will enable you to confirm whether the CAN signal in question has been received.

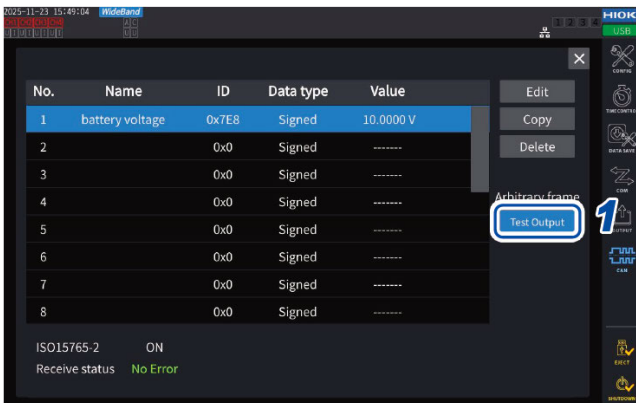

- 1 Tap **[Test Output]**.
The arbitrary frame(s) will be output.

IMPORTANT

The outputting of arbitrary frame(s) triggered by tapping **[Test Output]** is canceled when the CAN input database settings window is closed. Press the **START/STOP** key to officially start outputting the arbitrary frame(s).

Overview of the diagnostic measurement setup

Data can be acquired from the in-vehicle ECU (Electronic Control Unit) via CAN communication. This method is called “diagnostic measurement” and involves first sending the queried CAN signal to the ECU and then receiving data in response to that query from the ECU. Because the received data may exceed the 8 bytes that can be stored in a CAN frame, the ISO15765-2*1 communication standard is used. Using this diagnostic measurement setup function, the data to be retrieved from the ECU can be configured, enabling the simultaneous configuration of both the CAN input database settings and the output settings for the queried arbitrary frame.

Be aware that using this setup will enable ISO15765-2, causing the pre-configured CAN input database settings and the output settings for the arbitrary frame to be initialized.

*1 This standard was created by ISO (International Organization for Standardization) and defines a method for dividing a long message into multiple frames for transmission via CAN communication and then reassembling the original message on the receiving side.

Diagnostic measurement setup procedure

Display screen: **SYSTEM** key > **[CAN]**

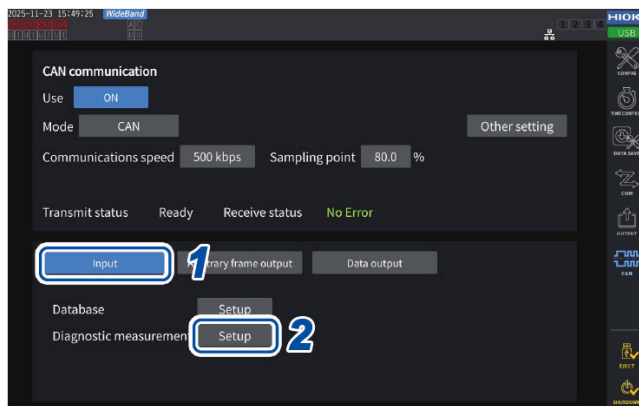

1 Tap **[Input]**.

2 Tap **[Setup]** in the **[Diagnostic measurement]** box.

A confirmation dialog box will be displayed regarding the enabling of ISO15765-2 and the overwriting of the CAN input database settings and the output settings for the arbitrary frame.

3 Tap **[Yes]**.

8.6 CAN Input Function

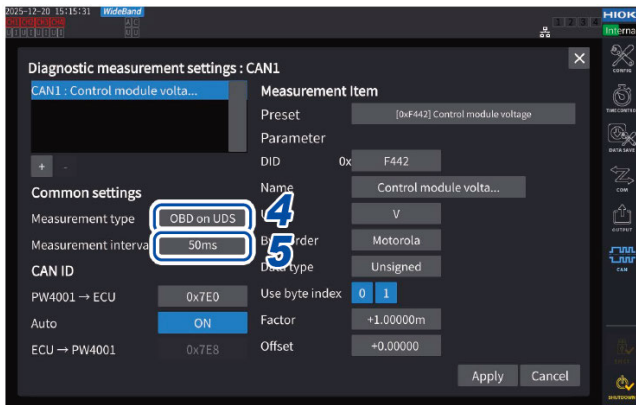

- *1 OBD II (On-board diagnostics II) is a self-diagnosis function programmed into the ECU. Diagnostic measurement enables data stored in the ECU to be acquired.
- *2 OBD on UDS (Unified Diagnostic Services) is a new diagnostic function that uses UDS to read OBD data.

- 4 Tap the **[Measurement type]** box and select a measurement type.

OBD II*1, OBD on UDS*2

- 5 Tap the **[Measurement Interval]** box and select the interval for data querying.

50 ms, 200 ms

IMPORTANT

The measurement type and measurement interval settings will be the same for all diagnostic measurements.

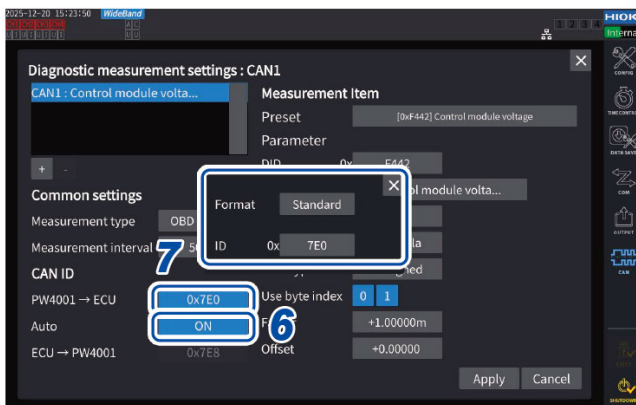

- 6 Tap the **[Auto]** box to select the automatic setting of the format and ID of the CAN signal returned as a response from the ECU.

ON	Set by predicting the format and ID of the set PW4001 → ECU.
OFF	The format and ID can be set as desired.

- 7 Tap the **[PW4001→ECU]** box and set the format and ID that the ECU requesting the data can accept.

Format		Standard/Extension
ID	[Auto]: When [ON] is selected	When [Standard] is selected: 0 to 7F7 (enter in hexadecimal) When [Extension] is selected: 0 to 1FFFFFFF (enter in hexadecimal)
	[Auto]: When [OFF] is selected	When [Standard] is selected: 0 to 7FF (enter in hexadecimal) When [Extension] is selected: 0 to 1FFFFFFF (enter in hexadecimal)

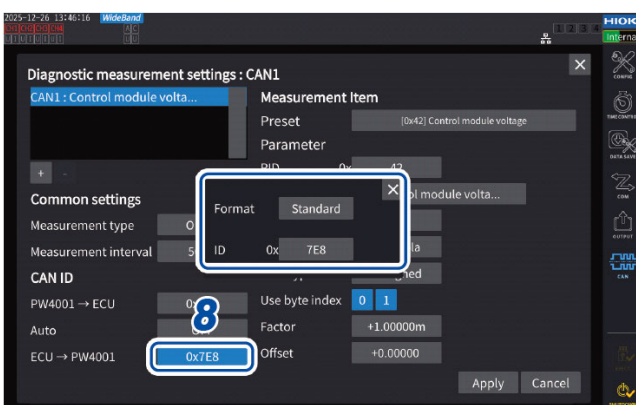

- 8 When **[OFF]** is selected for **[Auto]**, tap the **[ECU→PW4001]** box to set the format and ID of the CAN signal returned as a response from the ECU.

Format		Standard/Extension
ID		When [Standard] is selected: 0 to 7FF (enter in hexadecimal) When [Extension] is selected: 0 to 1FFFFFFF (enter in hexadecimal)

IMPORTANT

In diagnostic measurement, the CAN ID sent to the ECU includes a physical address directed to a single specific ECU and a functional address directed to multiple ECUs. When using this diagnostic measurement setup function, set the CAN ID of the physical address.

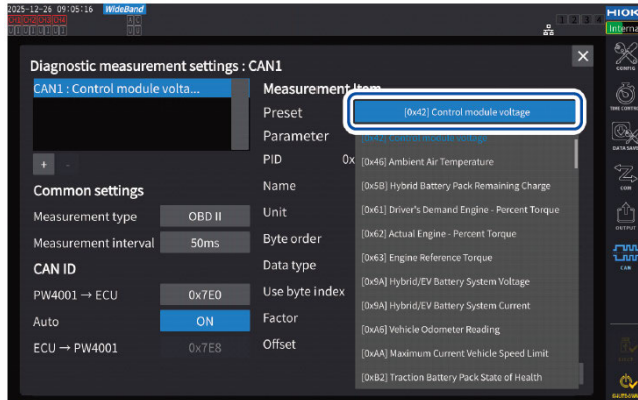

- 9 Configure each of the data items to be acquired.

If selecting from among OBD II standard PID or OBD on UDS standard DID:

Tap the **[Preset]** box and select the items to be acquired.

A list of items defined in SAE J1979 or J1979-2 will be displayed. The settings for the items shown below will be configured based on your selections.

If setting arbitrarily:

Configure the settings for each item.

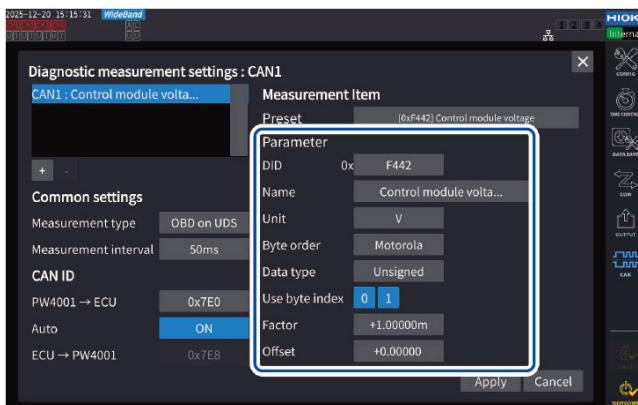

Acquired data settings

Item	Available selections	Description
PID (When measurement type [OBD II] is selected)	00 to FF (enter in hexadecimal)	Configure the parameter ID of the data to be acquired.
DID (When measurement type [OBD on UDS] is selected)	0000 to FFFF (enter in hexadecimal)	Configure the data ID of the data to be acquired.
Name	Up to 40 one-byte character strings Example: Speed	Set the name of the data to be acquired.
Unit	Up to 8 one-byte character strings Example: km/h	Set the unit of the data to be acquired.
Byte order	Little endian (Intel)/Big endian (Motorola)	Set the byte order of the data to be acquired.
Data type	Unsigned/Signed/Float/Double	Set the type of the data to be acquired. The number of bytes used is fixed at 4 bytes when the data type is Float and at 8 bytes when the data type is Double.
Use byte index		
No. of response bytes	1 to 64	Set the total number of bytes of data that the ECU returns for the specified PID/DID.
Start of used bytes	0 to 63	Set the start point of the use byte index from the data that the ECU returns. The start point cannot be set beyond the end point.
End of used bytes	0 to 63	Set the end point of the use byte index from the data that the ECU returns. The end point cannot be set before the start point.
Factor	Enter the value using the numeric keypad window.	Set the factor value of the data to be acquired.
Offset	Enter the value using the numeric keypad window.	Set the offset value of the data to be acquired.

IMPORTANT

- When any of the data acquisition settings are changed, **[Preset]** will be set to **[Custom]**.
- Depending on the specified PID/DID, multiple types of data may be returned together. In that case, the required data can be extracted by configuring the **[Use byte index]** setting to specify the number of response bytes and the byte index where the necessary data is stored.

Example: PID 0x9A specifies the hybrid EV system data, the 3rd and 4th bytes represent voltage, and the 5th and 6th bytes represent current. To acquire voltage data, set **[No. of response bytes]** as 6, **[Start of used bytes]** as 2, and **[End of used bytes]** as 3.

Example: PID 0x9A

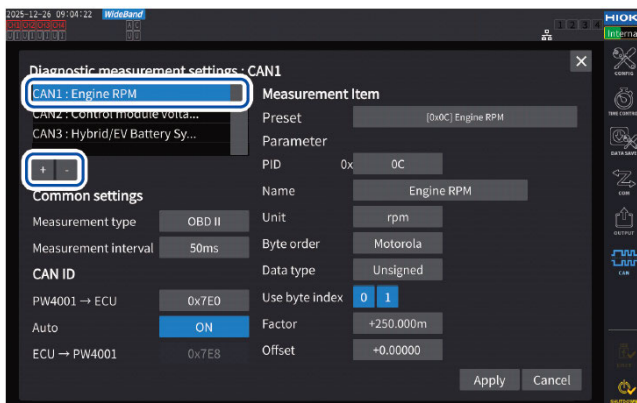
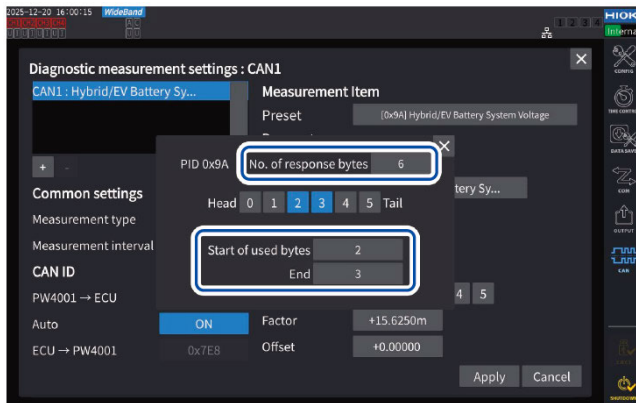
**10** (To also acquire other CAN data)

Tap **[+]** at the top left of the diagnostic measurement setting window to add a CAN setting.

Tap the CAN number to be configured and then proceed with the settings from step 6 onward while the CAN number is highlighted. Settings for up to six types of CAN data can be configured.

11 (To delete CAN data settings)

Tap on the CAN number to delete, and while it is highlighted, tap **[-]** to delete the CAN data setting.

The setting for the highlighted CAN number will be deleted and settings that follow the deleted CAN number will be moved forward.

8.6 CAN Input Function

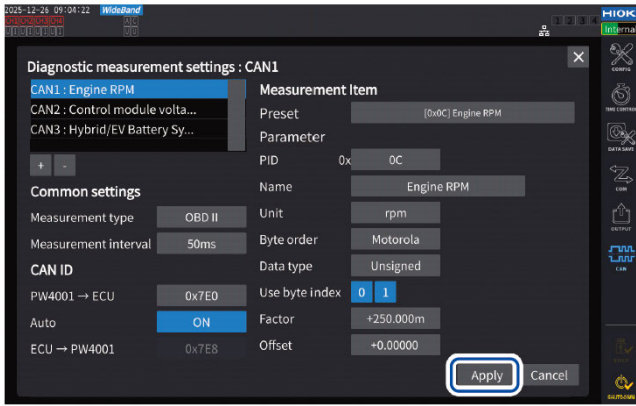

12 Tap **[Apply]** to apply the setting.

Settings will not be applied if you navigate to another screen without tapping **[Apply]**. Once settings are applied by tapping **[Apply]**, the CAN communication ISO15765-2 setting will be turned ON, and the CAN input database settings and optional frame output settings will be overwritten.

IMPORTANT

- Communication may not be performed correctly if CAN input settings and arbitrary frame output settings are changed after performing the diagnostic measurement setup. If performing diagnostic measurement after making changes, please perform the diagnostic measurement setup again.
- When querying the same ECU for multiple types of data, data IDs are sent together in a single query. Measurement will not be performed correctly if the order of the data IDs stored in the query differs from the order of the data returned from the ECU.

8.7 VT1005 AC/DC High Voltage Divider

The VT1005 is an AC/DC high voltage divider that converts an input voltage of up to 5 kV (no measurement category) into a one-thousandth for output with high accuracy.

The device has good flatness in frequency characteristics and stable temperature characteristics. It can be used not only for voltage measurement but also for high-precision power measurement by combining it with a wattmeter.

Display screen: **INPUT** key > **[CHANNEL]**



- 1 Tap the channel detail display area for the channel you wish to configure to open the settings window.

8.7 VT1005 AC/DC High Voltage Divider

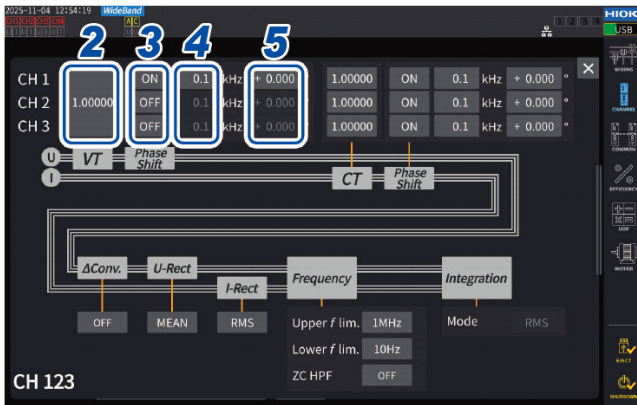

- 2 Tap the **[VT]** box and enter **[1000.00]** using the numeric keypad.
You can directly read values input from the VT1005 by setting the VT1005's dividing ratio to the Power Analyzer.
- 3 Set the voltage phase compensation to **[ON]**.
- 4 Set the frequency to **[100.0]** kHz.
- 5 Enter a phase compensation value appropriate for the length of the L9217 Connection Cord used with the VT1005.

Model name (length)	Compensation value of phase difference between input and output (°)
L9217 (1.6 m)	-4.01
L9217-01 (3.0 m)	-4.26
L9217-02 (10 m)	-5.52

By setting the phase compensation value in the Power Analyzer, the instrument can perform phase compensation for the Divider and reduce errors in power measurement in the high-frequency region.

The setting varies with the Power Analyzer in use.

IMPORTANT

Enter the phase compensation value accurately. Mistaken settings can cause the compensation process to increase measurement error.

9

Connecting with Computers

The instrument comes with LAN and USB interfaces. When connected to a computer, the instrument can be controlled using communications commands and measured data can be transferred to the computer.

CAUTION



- **Do not disconnect the communication cable or remove the SD memory card while the device is sending or receiving data.**

Doing so could damage the instrument and the computer.

- **Ground the ground terminals of the instrument and the computer at the same location.**

Connecting the cable when there is a difference in ground potentials between them could cause damage or malfunction.



- **Turn off the instrument and computer before connecting or disconnecting cables.**

Failure to do so could damage the instrument and the computer being connected or cause them to malfunction.

- **After connecting the communications cable, tighten the screws on the connectors.**

Otherwise, data may not be transferred properly.

IMPORTANT

- Use one of the above interfaces. Simultaneous use of multiple interfaces may cause the instrument to malfunction, such as communication interruption.
- If both a LAN cable and a USB cable are connected, USB communication will take priority.

Interface function list

Interface	Function	See
USB	Download data saved on the internal memory to a computer using USB mass storage mode	p.285
	Control the instrument by sending communications commands	p.310
	Transfer measured data to a computer using PW Data Receiver (PC application software)	p.312
LAN	Remotely operate the instrument (settings, screen monitoring) from a general web browser, such as Microsoft Edge using the HTTP server function	p.292
	Download data saved on a USB flash drive or in the internal memory to a computer using the FTP server function	p.295
	Automatically send waveform data saved on the USB flash drive connected to the instrument to a computer on the network or the FTP server of a remote computer using the FTP client function	p.298
	Control the instrument by sending communications commands (You can control the instrument TCP/IP-connected with a computer through the communications command port by sending communications commands from a program you created.)	p.310
	Remotely operate the instrument and transfer measured data to a computer using GENNECT One (PC application software)	p.311
	Use the Modbus/TCP communication function to acquire the control and measured data of the instrument in real time	p.315
	Remotely operate the instrument and transfer measured data to a computer using PW Data Receiver (PC application software)	p.312

Please download the PW Data Receiver (with the instruction manual) and GENNECT One (with the instruction manual), as well as the Modbus/TCP Communications instruction manual and Communication Command Instruction Manual from the Hioki website.

 See "Information on download site" (p.7)

9.1 USB Connections and Settings

Instrument settings and measurement data can be acquired by using a USB cable to connect the instrument with a computer.

IMPORTANT

- Data cannot be read from a USB flash drive connected to the instrument using a USB cable. To read data from a USB flash drive, insert the USB memory stick into the computer's USB port.
- Control via USB communication is possible using a computer equipped with the following operating systems. Because the standard Windows driver is used, there is no need to install a dedicated driver.
Windows 10, Windows 11

USB cable connections

- 1 Check the orientation of the USB cable before inserting it into the instrument's USB port.
- 2 Connect the other end of the USB cable to the computer's USB port.

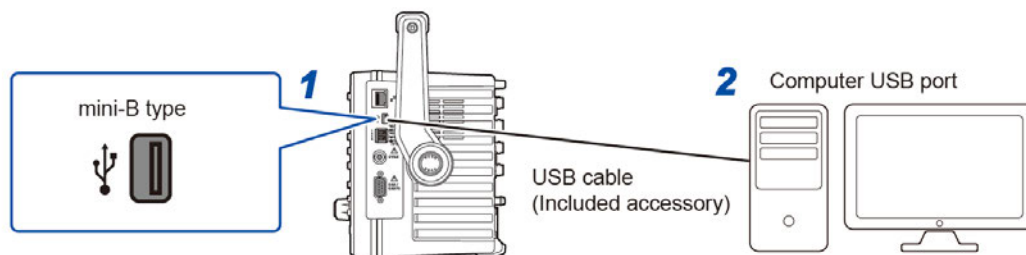

Once the connection with the computer is established, the USB icon will be displayed in the upper right corner of the instrument screen.

Acquiring data in USB mass storage mode

Display screen: **SYSTEM** key > **[COM]**

9.1 USB Connections and Settings

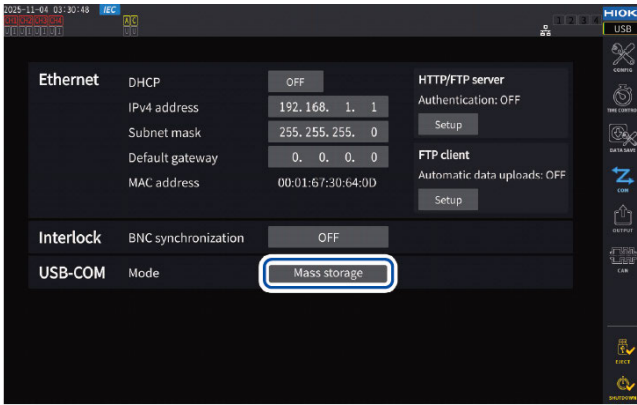

1 Select **[Mass storage]** in the **[Mode]** box for **[USB COM]**.

2 Connect the instrument to a computer using a USB cable.

The mode will automatically switch to USB mass storage mode when a USB communication connection is established while the **[Mode]** for **[USB COM]** is set to **[Mass storage]**.

IMPORTANT

The instrument cannot be operated while in USB mass storage mode. Communication commands can also not be executed.

Exiting USB mass storage mode

Take the instrument out of USB mass storage mode.

- 1 Click the USB icon ([**Safely Remove Hardware and Eject Media**]) shown in the computer task tray.
- 2 Click [**- Eject INTERNAL**].

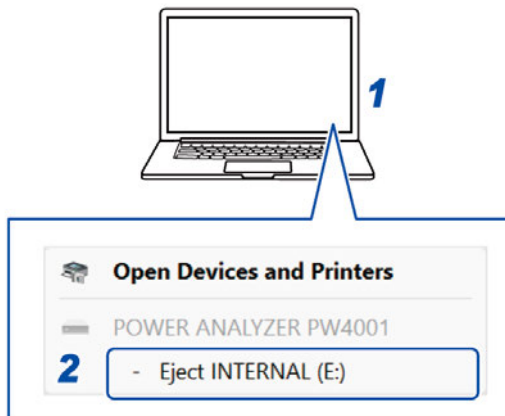

The [**Safe To Remove Hardware**] window will be displayed.

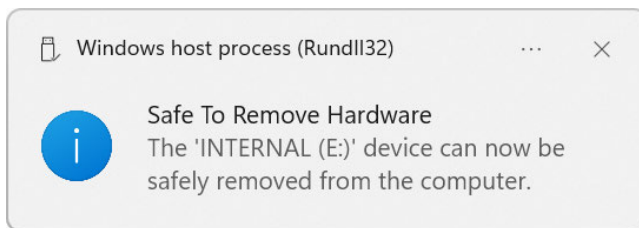

- 3 Disconnect the USB cable.

9.2 LAN Connections and Settings

The instrument ships standard with a LAN interface. Use a LAN cable to connect the instrument and a computer.

🔍 See “Interface function list” (p.284)

Connecting a LAN cable

Connect a LAN cable to the RJ-45 (Gigabit Ethernet) connector of the instrument.

⚠️ CAUTION



■ **If routing a LAN cable outdoors or over 30 m, attach a LAN surge protector or another suitable protective device.**

Failure to do so could cause damage to the instrument due to increased susceptibility to the effects of induced lightning.

IMPORTANT

When using the LAN interface, do not use USB communication. Simultaneous use of multiple interfaces may cause the instrument to malfunction, such as communication interruption.

📌 Tips

If communication with the computer is unstable

Depending on the measurement environment, communication between the instrument and computer may become unstable due to noise. In such a case, use a Category 6A or higher STP (Shielded Twisted-Pair) LAN cable.

How to connect a LAN cable

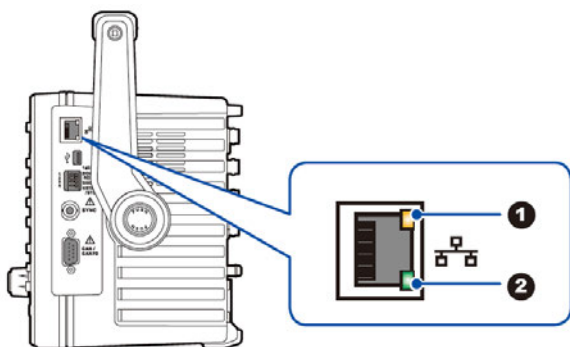

RJ-45 connector

1	ACT LED (orange)	Flashing: Sending/receiving data
----------	------------------	----------------------------------

②	LINK LED (green)	On: Connection established Off: Connection not established
---	------------------	---

Once the connection with the computer is established, the LAN icon will be displayed in the upper right corner of the instrument screen.

Example connection: Connecting one instrument and one computer (connecting the instrument to a computer)

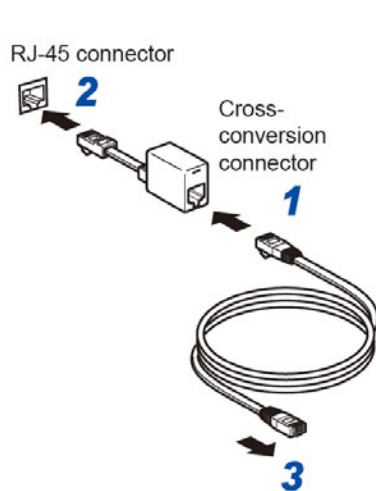

- 1** Connect the cross-conversion connector to the LAN cable.
- 2** Connect the cross-conversion connector to the instrument's LAN interface.
- 3** Connect the LAN cable to the computer's 100Base-TX connector.



When a cross-conversion connector is not available

The instrument can be connected to a computer using a hub.

Configuring LAN settings and building a network environment

LAN settings (for the instrument)

You must configure the LAN settings before connecting the instrument to a network. If you change the LAN settings while the instrument is connected to a network, the instrument may have the same IP address as another device on the LAN, causing incorrect address information to be sent to the LAN.

Display screen: **SYSTEM** key > **[COM]**

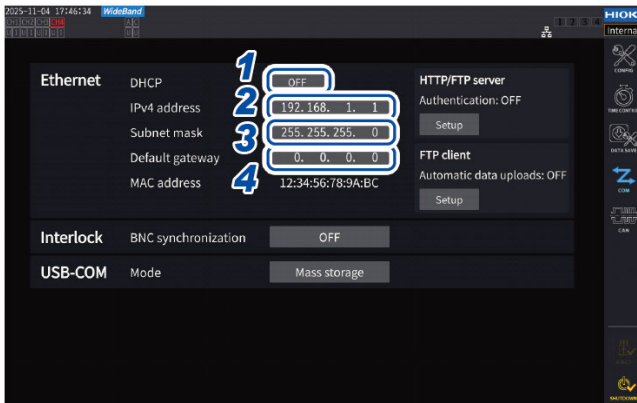

1 Tap the **[DHCP]** box to set it to ON or OFF.

The Dynamic Host Configuration Protocol (DHCP) is a method by which devices can automatically acquire and configure themselves with an IP address and other information. When this DHCP function is enabled and there is a DHCP server operating on the same network, the instrument can automatically acquire the settings of IP address, subnet mask, and default gateway.

(Follow the steps below only when set to OFF.)

2 Tap the **[IPv4 address]** box and then enter the IPv4 address using the numeric keypad.

The IP address is used to identify individual devices connected to the network. Use a unique address that no other device on the network is using.

The instrument uses IP version 4, and IP addresses are expressed as a series of four decimal numbers separated by periods, such as 192.168.1.1. If the DHCP setting is enabled, the IP address will be configured automatically by DHCP.

3 Tap the **[Subnet mask]** box and then enter the subnet mask using the numeric keypad.

The subnet mask is used to separate the IP address into the portion that indicates the network and the other portion that indicates the device.

The subnet mask typically consists of a series of four decimal numbers separated by periods, such as 255.255.255.0.

If you enter an invalid value, the subnet mask is not changed.

If the DHCP setting is enabled, the IP address will be configured automatically by DHCP.

4 Tap the **[Default gateway]** box and enter the default gateway using the numeric keypad.

The default gateway specifies the IP address of the device that serves as the gateway when the computer with which you are communicating is on a different network than the instrument.

When not using a gateway (for example, when using a one-to-one connection), set the instrument's gateway to 0.0.0.0.

If the DHCP setting is enabled, the default gateway will be configured automatically by DHCP.

Example network environment architectures

Example 1: Connecting the instrument to an existing network

When connecting the instrument to an existing network, you must first have the network system administrator (department) allocate the following settings. Ensure that the instrument uses a unique address not being used by any other device on the network.

IP address	_____ . _____ . _____ . _____
Subnet mask	_____ . _____ . _____ . _____
Default gateway	_____ . _____ . _____ . _____

Example 2: Adding a LAN port to a computer connected to an existing network and connecting the instrument to the new port

Configure the IP address, subnet mask, and default gateway of the new LAN port after verifying the proper settings with your network system administrator.

Example 3: Connecting one computer and multiple instruments using a hub

When creating a local network not connected externally, it is recommended to use private IP addresses such as those shown in the example.

When creating a network with a network address of 192.168.1.0/24

IP address	Computer: 192.168.1.1 Instrument: 192.168.1.2, 192.168.1.3, 192.168.1.4, etc. (progressing in order)
Subnet mask	255.255.255.0
Default gateway	0.0.0.0

Example 4: Connecting a computer and the instrument one-to-one

When connecting a computer and the instrument one-to-one, you may set the IP address as desired. However, it is recommended to use a private IP address.

IP address	Computer: 192.168.1.1 Instrument: 192.168.1.2 (Use a different value for the IP address.)
Subnet mask	255.255.255.0
Default gateway	0.0.0.0

9.3 Remotely Operating the Instrument Through the HTTP Server

The instrument comes with the HTTP server function. This function enables the instrument to be controlled remotely using a general web browser, such as Microsoft Edge. The web browser will display the instrument's screen and control panel. The control panel also allows you to check the channel indicators' on/off status.

The remote operation can be performed in the same manner as with the actual instrument. However, the control panel does not allow the keys to be held down or pressed simultaneously.

When operating the instrument remotely from an HTTP server, do not control the instrument using communication commands or using GENNECT One. Controlling the instrument from multiple devices simultaneously may cause malfunctions, such as stopping communication.

When you set the clock of the instrument while connecting the HTTP server, the communication may be lost.

Connecting to the HTTP server

- 1 Open a web browser, such as Microsoft Edge.
- 2 Enter the instrument's address in the address bar (e.g., http://192.168.10.11).
- 3 (When **[HTTP/FTP server authentication]** on the instrument is set to **[ON]**)
Enter the username and password to log in.
Display of the main page indicates that you have successfully connected to the instrument.

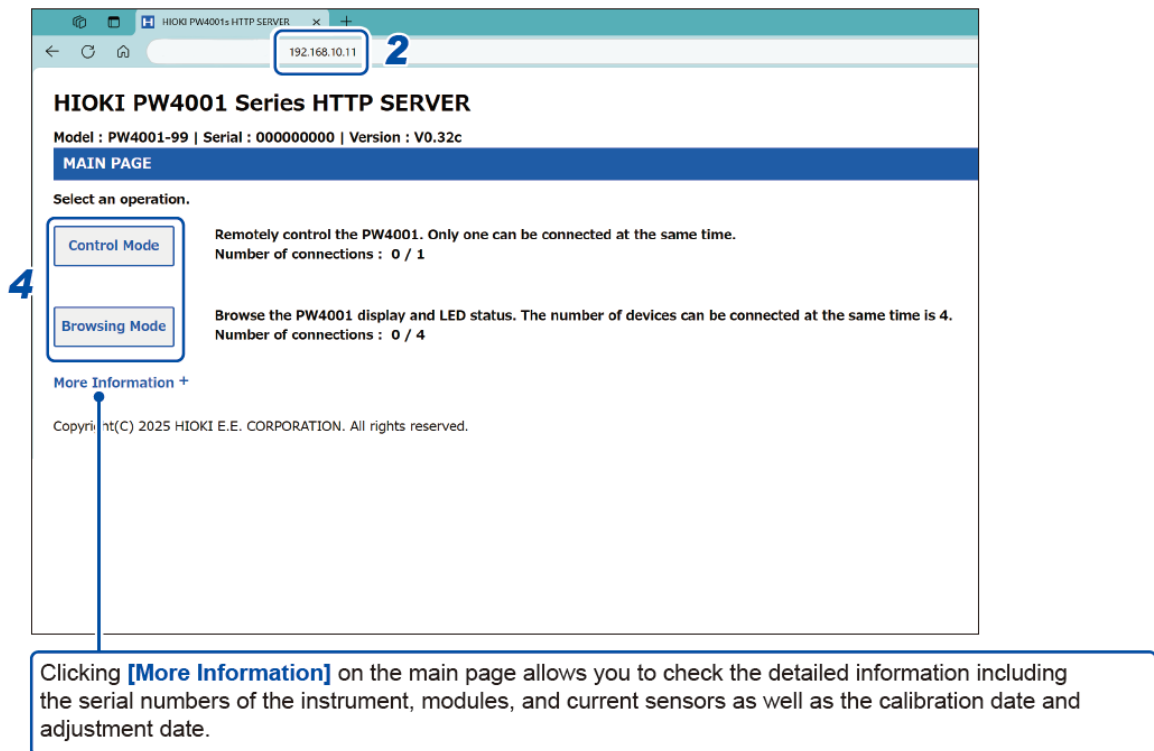

- 4 Choose between **[Control Mode]** and **[Browsing Mode]**.

Up to five computers can connect to a single PW4001.

<p>Control Mode</p>	<p>Allows you to check the instrument screen, control panel, and channel indicator's on/off status in a web browser.</p> <p>Clicking the screen in the web browser enables you to operate the instrument in the same manner as with the touchscreen and control panel.</p> <p>Rotating the cursor while pointing to the X or Y rotary knob can operate the X or Y rotary knob, respectively.</p> <p>Display update interval: 200 ms, 1 s, 5 s, 10 s</p>
<p>Browsing Mode</p>	<p>Allows you to check the instrument screen, control panel, and channel indicator's on/off status in a web browser.</p> <p>Keys cannot be tapped or operated.</p> <p>Up to four computers can connect to a single PW4001.</p> <p>Display update interval: 200 ms, 1 s, 5 s, 10 s</p>

9.3 Remotely Operating the Instrument Through the HTTP Server

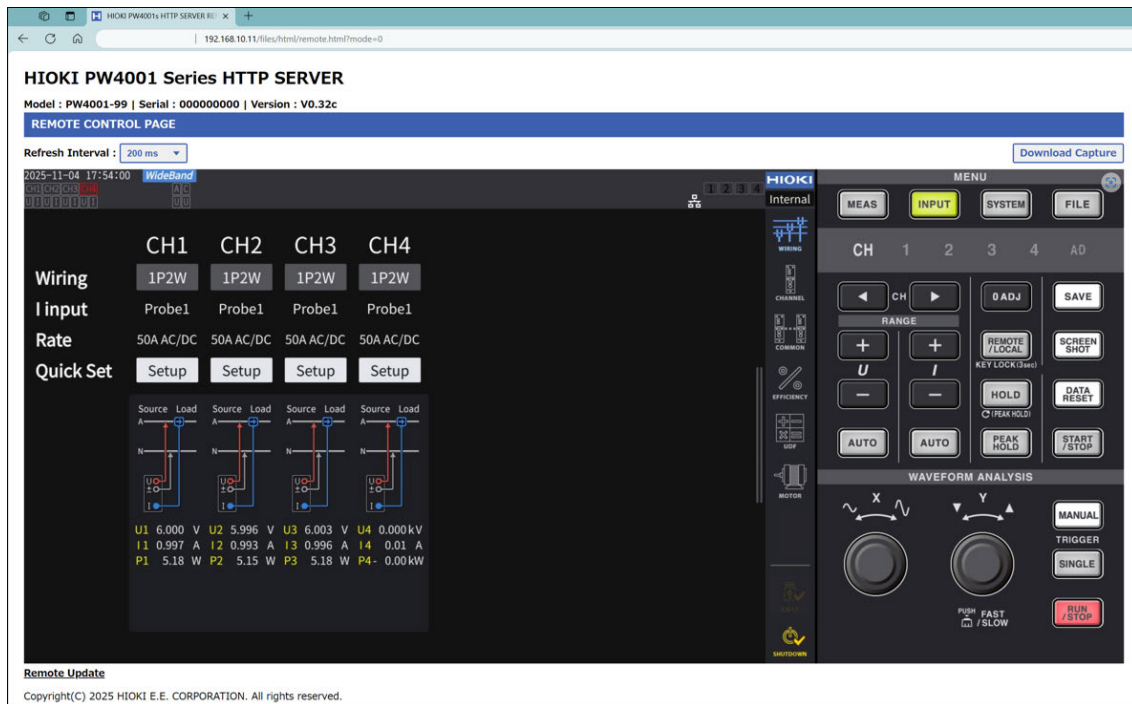

Tips If the main page is not displayed

- Check the instrument's LAN settings and the computer's IP address.
[See](#) "Configuring LAN settings and building a network environment" (p.290)
- Make sure that the LAN interface's LINK UP LED is lit up and that the LAN icon (📶) is shown on the instrument's screen.
[See](#) "Connecting a LAN cable" (p.288)
- Proper operation may not be possible with some web browsers. Try to use other web browsers.

To save screenshots

Pressing the **[Download Capture]** button in the upper right allows you to save the currently displayed screen.

9.4 Acquiring Data through the FTP Server

With the FTP server function, files stored on a USB flash drive or in the internal memory can be acquired on a computer.

- The instrument has a built-in FTP (file transfer protocol, RFC959-compliant) server.
- Various free software programs are available for use as an FTP client.
- File update dates and times may not be displayed correctly depending on the FTP client.
- The instrument's FTP server supports only one connection. It is not possible to access it simultaneously from multiple computers.
- The FTP connection may be disconnected if one minute or more has elapsed without a command being sent after the connection is established. In this case, connect to the FTP server again.
- Disconnect the FTP connection before inserting and ejecting a USB flash drive.
- Do not perform file operation on the instrument while there is an active FTP connection.

You must configure the instrument and connect it to a computer using a LAN cable in order to use the FTP server function.

🔍 See “9.2 LAN Connections and Settings” (p.288)

IMPORTANT

Some computer's FTP clients and web browsers delete all files and folders being moved if the move operation is canceled, regardless of whether the files and folders had been transferred or not. Exercise caution when using the move command. It is recommended to copy (download) the files and folders and then delete them.

Be aware of the following items before using the FTP server function:

Relationship of media and directories	All media is shown as directories in the FTP session. /usb USB flash drive
Restriction	Files cannot be accessed while measurement is in progress.

Accessing the instrument's FTP server

This example explains how to access the FTP server using File Explorer in Windows. Launch File Explorer on the computer and enter the instrument's address into the address bar.

When **[HTTP/FTP server authentication]** on the instrument is set to **[ON]**, enter the username and password to log in.

Set the username and password to prevent third parties from deleting files by accident.

🔍 See “FTP server connection restriction (FTP authentication)” (p.296)

[ftp://Username:Password@Instrument's IP address]

For the username “HIOKI” and the password “PW4001”

Enter ftp://HIOKI:PW4001@192.168.10.11

If the instrument's IP address is 192.168.10.11

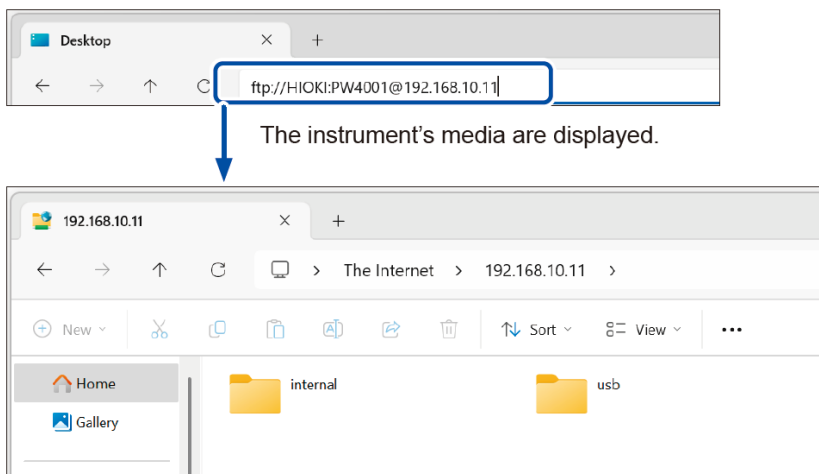

If connection is not possible

Check the instrument's communications settings.

🔍 See “9.2 LAN Connections and Settings” (p.288)

FTP server connection restriction (FTP authentication)

Access to the HTTP/FTP server can be restricted.

Normally the FTP server of the instrument is controlled by anonymous authentication and can be accessed from all the devices in the network.

Enable **[HTTP/FTP server authentication]** and set the username and password to restrict connection to the FTP server.

It is recommended to set the username and password and restrict access to prevent third parties from deleting files by accident.

Display screen: **SYSTEM** key > **[COM]**

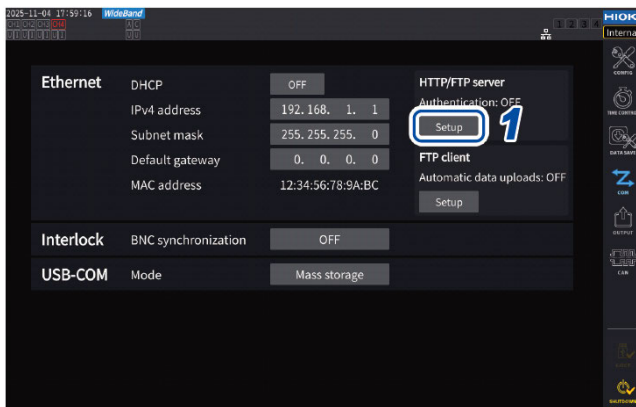

- 1 Tap the **[Set up]** under **[HTTP/FTP server]** box to open the setting window.

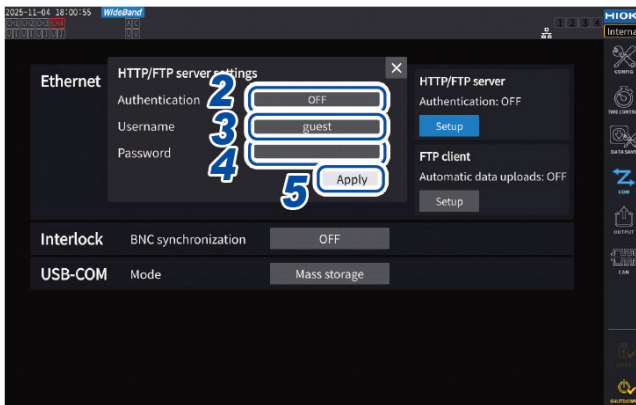

- 2 Tap the **[Authentication]** box to set it to **[ON]**.
- 3 Tap the **[Username]** box and then set the username using the numeric keypad window. (Up to 12 one-byte characters)
- 4 Tap the **[Password]** box and then set the Password using the numeric keypad window. (Up to 12 one-byte characters)
- 5 Tap **[Apply]** to confirm.

9.5 Sending Data Using the FTP Client Function

Any files saved on the instrument's media (USB flash drive or internal memory) can be sent to the FTP server of the computer.

Specify the IP address of the computer with the FTP server on the instrument.

Register the username and password of the instrument in the FTP server of the computer as well.

You can use some FTP servers, such as a Windows FTP server.



When uploading data with low available space on the media

Press the **SYSTEM** key to access the **[COM]** screen and then set **[Delete files after upload]** to **[ON]**.

The files of the instrument are deleted after they are uploaded to the FTP server.

Data can be uploaded automatically or manually.

See "Sending files manually" (p.305)

Setting automatic file upload

Any files saved in the instrument's media can be automatically uploaded to the FTP server of the computer. The following shows an example of uploading data to FTP server with the IP address of 192.168.1.1.

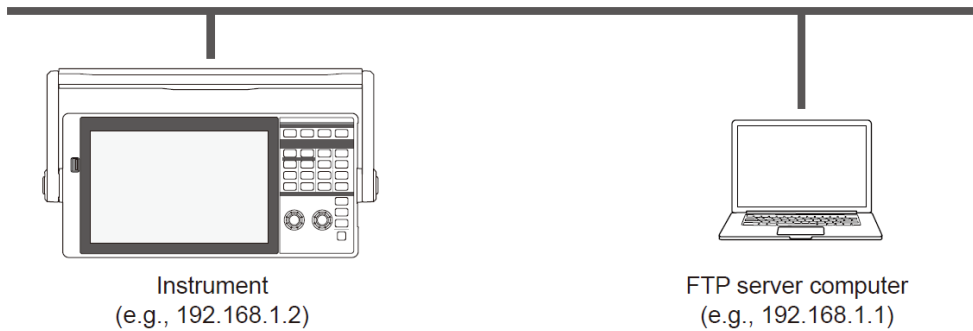

Operating procedure

- 1** Configure the LAN settings using the instrument and connect the instrument to LAN.

🔍 See “9.2 LAN Connections and Settings” (p.288)

- 2** Configure the FTP server settings using the receiving side equipment (computer).

- 3** Perform automatic FTP upload using the instrument.

- 4** Configure the auto-save settings using the instrument.

🔍 See “Setting automatic file upload” (p.299)

- 5** Start measurement using the instrument.

When the instrument has finished automatically saving a file, it will be automatically sent to the FTP server of the computer.

- 6** Check communications status between the instrument and the computer.

🔍 See “Checking FTP communication status” (p.303)

Display screen: **SYSTEM** key > **[COM]**

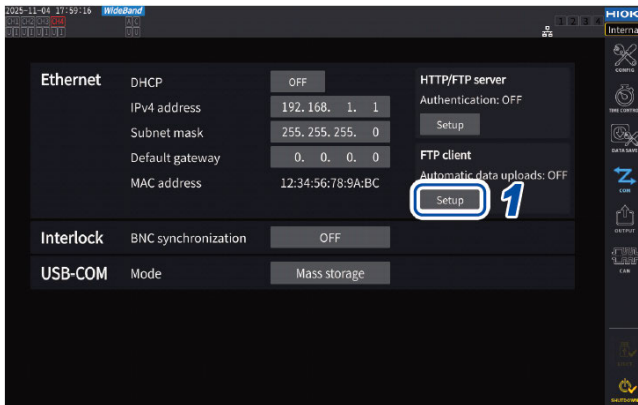

- 1 Tap the **[Setup]** box under **[FTP client]** to open the setting window.



- 2 Set each item under **[FTP client settings]**.
- 3 When the FTP setting is completed, tap **[Test Upload]**.
 See “File upload test” (p.301)

FTP client settings

Item	Available selections	Description
Automatic file upload	ON or OFF	
FTP server name	Up to 45 one-byte character strings Example 1: FTPSERVER Example 2: 192.168.1.1	Host name or IP address of the FTP server
Port number	1 to 65535	Port number of the FTP server
Username	Up to 32 one-byte character strings Example: HIOKI	Username for logging in to the FTP server
Password	Up to 32 one-byte character strings Example: PW4001	Password for logging in to the FTP server The password is displayed as [●●●●●].
Destination directory	Up to 45 one-byte character strings Example: data	Directory on the FTP server for saving data
Passive mode	ON or OFF	Allows you to select whether or not to use the PASV mode during communication.

Delete files after upload	ON or OFF	Select whether to delete the original file after it is successfully uploaded.
Filename extension Serial number IP address Date and time	ON or OFF	Adds identifiers whose boxes are checked to ON to the filename.

Filename example

When the **[Serial number]**, **[IP address]**, and **[Time and date]** check boxes are set to **[ON]**, the file is named **[123456789_192-168-1-2_210110-123005_01100000.CSV]**.

Files can be identified when multiple wattmeters are used.

Serial number	123456789
IP address	192.168.1.2
Date and time	21-01-10 12:30:05
Auto-save filename	01100000.CSV

File upload test

Check whether files can be uploaded using the FTP client.

Display screen: **SYSTEM** key > **[COM]**

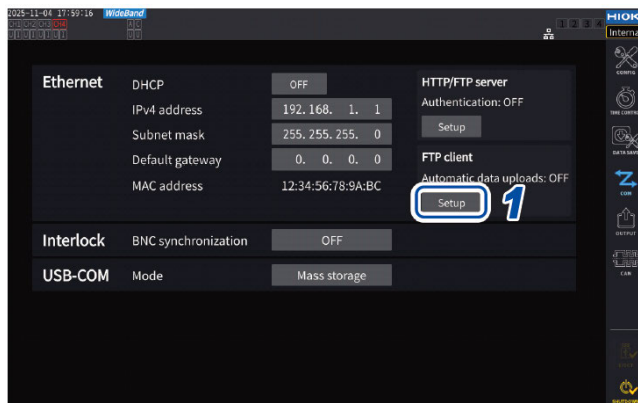

- 1 Tap the **[Setup]** box under **[FTP client]** to open the setting window.

The identification name selected under **[Filename extension]** is added to the test filename.

9.5 Sending Data Using the FTP Client Function

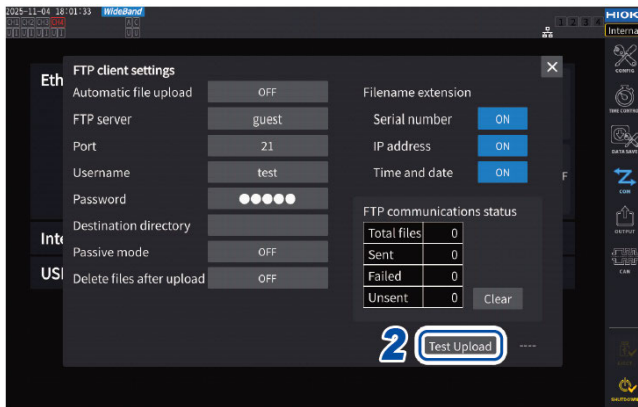

2 Tap [Test Upload].

Test file [FTP_TEST.TXT] is uploaded to the folder specified in [Destination directory].

When [PASS] is displayed, the file has been successfully uploaded.

When [FAIL] is displayed, the file upload has failed.

When the test file cannot be uploaded, check the automatic file upload settings of the instrument and the FTP settings of the computer.

3 Start measurement when the result of the test upload is [PASS].

The instrument automatically uploads the data of the measured waveforms to the FTP server.

Files to be uploaded automatically

The following files are automatically uploaded after being created.

- Auto-save file
- Settings file
- Waveform file
- Screenshot file

Data send time

(Transfer time [s]) = (File size [KB]) / (Transfer speed [KB/s]) + (Transfer preparation time [s])

For more information about file sizes, see “Recordable time and data” (p.214).

For reference, assume that the transfer speed is 4 MB/s and the transfer preparation time is 3 s.

Example: When the file size is 40 MB

$$(Transfer\ time) = 40\ (MB) / 4\ (MB/s) + 3\ (s)$$

$$= 10 + 3\ (s) = 13\ (s)$$

Checking FTP communication status

The FTP communication status can be checked.

The numbers of files, such as those the FTP client successfully sent and failed to send, are displayed.

Display screen: **SYSTEM** key > **[COM]**

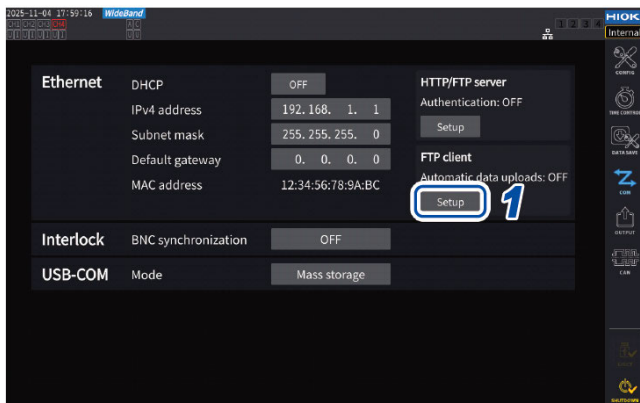

- 1 Tap the **[Setup]** box under **[FTP client]** to open the setting window.

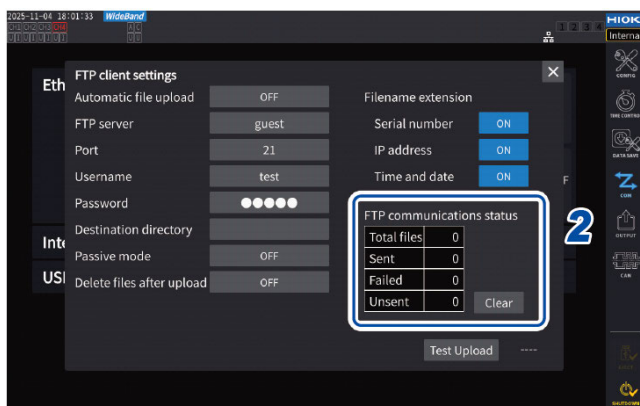

- 2 Check the number of files under **[FTP communications status]**.

The following zeros the counters.

9.5 Sending Data Using the FTP Client Function

- When **[Clear]** is tapped
- When the instrument is turned on

Once a file fails to be sent, the Unsent count increases by one. After a certain period, the file is retransmitted, reducing the Unsent count by one. Successful transmission of this file increments the Sent count by one, and failure increments the Failed count by one.

Tapping **[Clear]** zeros all counters and stops the retransmission of unsent files.

Sending files manually

Any files saved in the USB flash drive connected to the instrument can be sent to the FTP server of the computer anytime.

Only files can be sent manually. Folders cannot be sent manually.

Operating procedure

- 1** Configure the LAN settings using the instrument and connect the instrument to LAN.
 🔍 See “9.2 LAN Connections and Settings” (p.288)
- 2** Configure the FTP server settings using the receiving side equipment (computer).
- 3** Configure the FTP client using the instrument.
 🔍 See “9.5 Sending Data Using the FTP Client Function” (p.298)
- 4** Send files to the FTP server on the **[FILE]** screen.
 🔍 See “Manual file transfer (uploading to an FTP server)” (p.227)

Display screen: **FILE** key

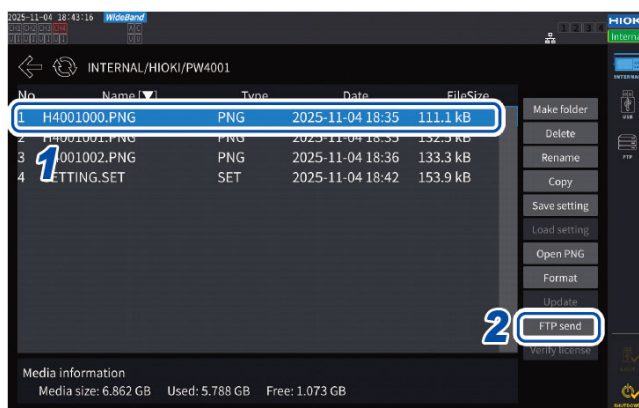

- 1** Tap the file to be sent.
- 2** Tap **[FTP send]** to open the setting window.



- 3** Configure the FTP client.
 🔍 See “Setting automatic file upload” (p.299)
- 4** Tap **[Send]**.
 The file is transferred to the specified FTP server.

9.6 FTP Server Mounting Function

Some of the files that can be created by the instrument can be created directly on the FTP server by communicating with the FTP server on a computer and without using media (USB flash drive or internal memory). You can also load settings files on the FTP server to the instrument.

Register the username and password of the instrument on the FTP server before using this function.

You can use some FTP servers, such as a Windows FTP server.

Settings for saving files on the FTP server

Files can be created directly on the FTP server without using the instrument's media.

The following shows an example of uploading data to FTP server with the IP address of 192.168.1.1.

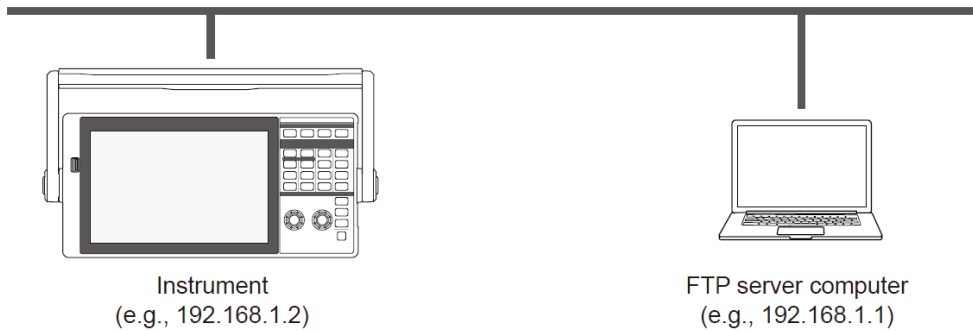

Only settings files and screenshot files can be created on the FTP server.

Other files are created on the instrument's media.

Operating procedure

- 1 Configure the LAN settings using the instrument and connect the instrument to LAN.
 🔍 See "9.2 LAN Connections and Settings" (p.288)
- 2 Configure the FTP server settings using the receiving side equipment (computer).
- 3 Configure the file saving settings for the FTP server using the instrument.
 🔍 See "FTP client settings" (p.308)
- 4 Create a settings file or a screenshot file with the instrument.

Display screen: **SYSTEM** key > **[DATA SAVE]**

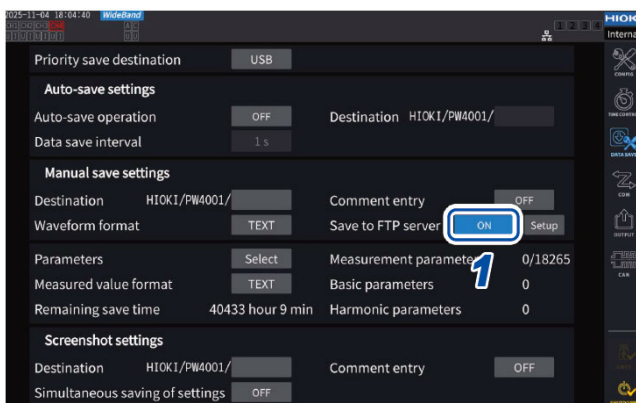

- 1 Tap the **[Save to FTP server]** box to set it to **[ON]**.

9.6 FTP Server Mounting Function

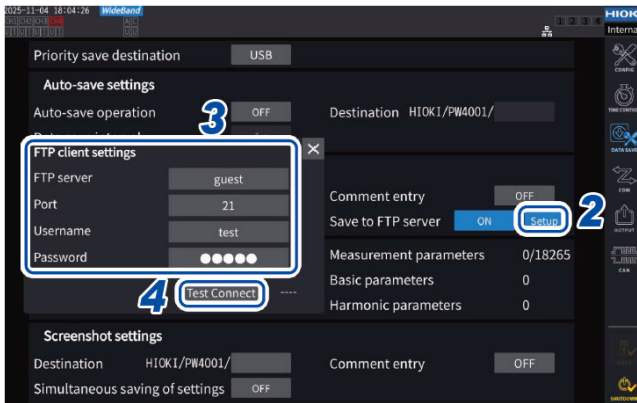

- 2 Tap **[Setup]**.
The setting window will be displayed.
- 3 Set each item under **[FTP client settings]**.
- 4 When the FTP client settings are completed, tap **[Test Connect]**.
When it successfully communicates, the instrument displays **[PASS]**.

FTP client settings

Item	Available selections	Description
FTP server name	Up to 45 one-byte character strings Example 1: FTPSERVER Example 2: 192.168.1.1	Host name or IP address of the FTP server
Port number	1 to 65535	Port number of the FTP server
Username	Up to 32 one-byte character strings Example: HIOKI	Username for logging in to the FTP server
Password	Up to 32 one-byte character strings Example: PW4001	Password for logging in to the FTP server. The password is displayed as [●●●●●] .

These settings are common to those used when automatically uploading files using the FTP client.

Save destination folders for created files

Save destination folders for files created on the FTP server vary depending on the file type.

File type	Save destination folder
Instrument settings file (extension: SET)	Folder of the FTP server currently displayed on the [FILE] screen Tap [Save setting] and enter a filename to create.
UDF (User-defined formula) settings file (extension: JSON) CAN database settings file (extension: DBC)	Folder specified as the save destination for manual save settings
Screenshot file	Folder specified as the save destination for screenshot settings

Loading settings files from the FTP server

A saved settings file on the FTP server is loaded to restore settings.

Display screen: **FILE** key

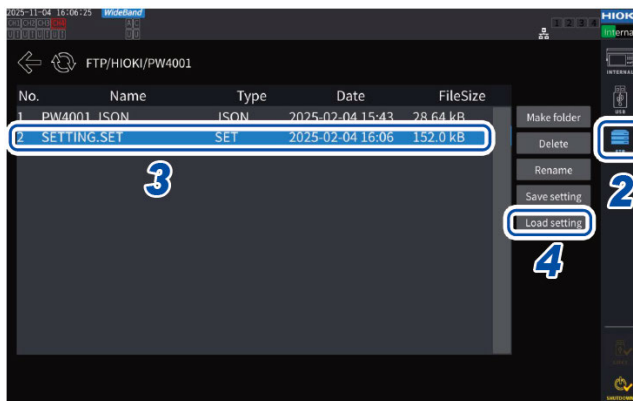

1 Tap **[Setup]** in **[Save to FTP Server]** to configure the settings for the destination FTP server.

🔍 See “Settings for saving files on the FTP server” (p.307)

2 Tap the **[FTP]** icon.

3 Tap a settings file to select it.

4 Tap **[Load setting]**.

A confirmation dialog box is displayed.

5 Tap **[Yes]**.

The combination of options, etc., must be identical to restore the settings. If not, the settings cannot be restored.

9.7 Controlling the Instrument with Communications Commands

The computer sends communications commands, which can control the instrument and communicate with it.

Connect the instrument and computer via LAN or USB cable.

For details about communication commands, see the Communication Command Instruction Manual.

Do not operate the instrument remotely from an HTTP server or control the instrument from GENNECT One while communication commands control the instrument. Controlling the instrument from multiple devices simultaneously may cause malfunctions, such as stopping communication.

9.8 GENNECT One (PC Application Software)

GENNECT One is application software for observing measured values in real time and acquiring measurement files with the instrument and computer connected with a LAN cable.

Do not operate the instrument remotely from an HTTP server or control the instrument using communication commands while GENNECT One controls the instrument. Controlling the instrument from multiple devices simultaneously may cause malfunctions, such as stopping communication.

Please download GENNECT One from Hioki's website.

🔍 See "Information on download site" (p.7)

Main functions

Function	Description
Logging	You can log measured values of the LAN-connected measuring instrument at specified intervals, enabling the displaying of graphs and lists in real time.
Dashboard	This function places measured values over any background image, enabling measurement conditions to be visually monitored easily. Threshold values can be set for each measurement item and alarm information can be saved in the computer when a measured value exceeds the threshold value.
Remote operation	You can operate the LAN-connected measuring instrument using its HTTP server function.
File acquisition Automatic file transfer	You can acquire files from external storage devices connected with the measuring instrument. Files created on the measuring instrument can be received on the computer using the FTP function between the measuring instrument and computer. This function can also be used for measured value data from other Hioki measuring instruments. For GENNECT One compatible models, check the Hioki website.

For more information, visit the Hioki website.

System requirements

Supported operating systems	Windows 8.1 (32-bit, 64-bit) Windows 10 (32-bit, 64-bit) Windows 11
Software requirements	Microsoft .NET Framework 4.6.2 or later
CPU	Operation clock of 2 GHz or more
Memory	4 GB or more
Display	Resolution of 1366 × 768 dots or more
Hard disk	1 GB or more of free space

See the "GENNECT One User's Manual" for details about how to use GENNECT One.

Select Help on the GENNECT One information menu to display the manual.

9.9 PW Data Receiver (PC Application Software)

PW Data Receiver is an application that enables up to eight PW4001 units to be connected to a computer via LAN or USB in order to acquire measured values, create files, and control the instruments remotely. Do not operate the instrument remotely from an HTTP server or control the instrument using communication commands during communication with the PW Data Receiver. Controlling the instrument from multiple devices simultaneously may cause malfunctions, such as stopping communication. Please download PW Data Receiver from Hioki's website.

🔍 See "Information on download site" (p.7)

Main functions

Function	Description
Save measured values	Acquire measured values for selected measurement items at specified intervals and save them to a file.
Save waveforms	Save currently displayed waveform data to a file.
Remote operation	Use the HTTP server function to control the instrument during communication.
File acquisition	Use the FTP server function to acquire files from the instrument's internal memory or from external storage during communication.

For more information, see the PW Data Receiver Instruction Manual (PDF, included with application software).

System requirements

	Minimal	Recommended
Operating system	Windows 11 (64-bit), Windows 10 (64-bit) Version 21H2 and later	
Processor	Intel® Core i3 or higher, or an equivalent processor	Intel® Core i7 or higher, or an equivalent processor
Memory	4 GB or more	8 GB or more
Storage	250 GB or more	SSD of 500 GB or more
Display	High definition (1366×768) or higher	Full HD (1920×1080) or higher
Interface	LAN	
Input devices	Keyboard, mouse or touchpad	

Installation procedure

- 1 Double-click **[Setup_PWDataReceiver_x.xx.x.exe]** to run it.



Start the installation.

- 2 If the following warning message appears, click **[Yes]**.

The warning message may not be displayed depending on your settings.

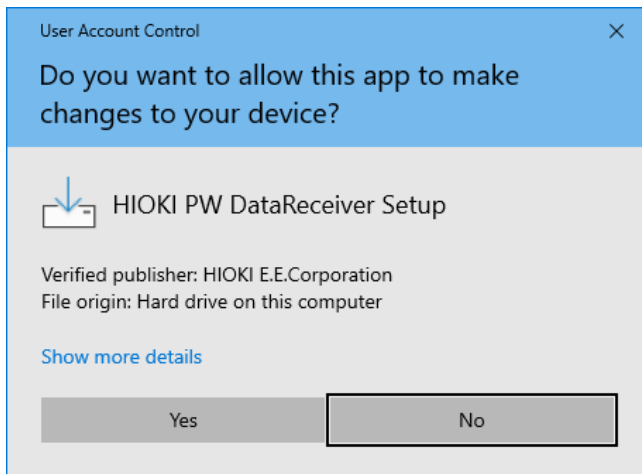

The setup screen will be displayed.

3 Click **[Next]**.



4 To create a shortcut on the computer desktop, check the **[Create a desktop shortcut]** check box.

5 Click **[Next]**.

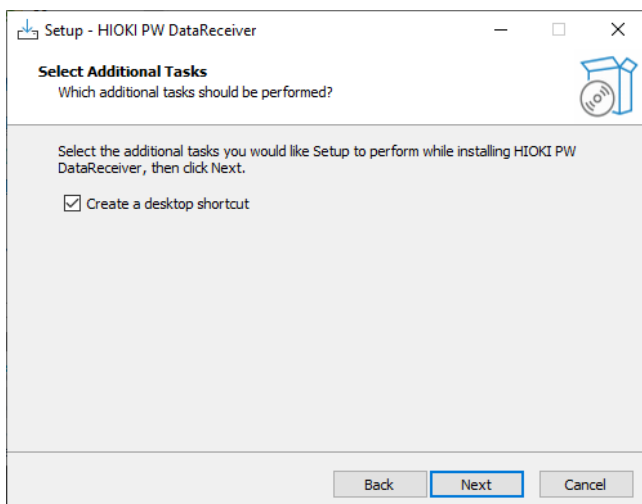

6 Click **[Install]**.

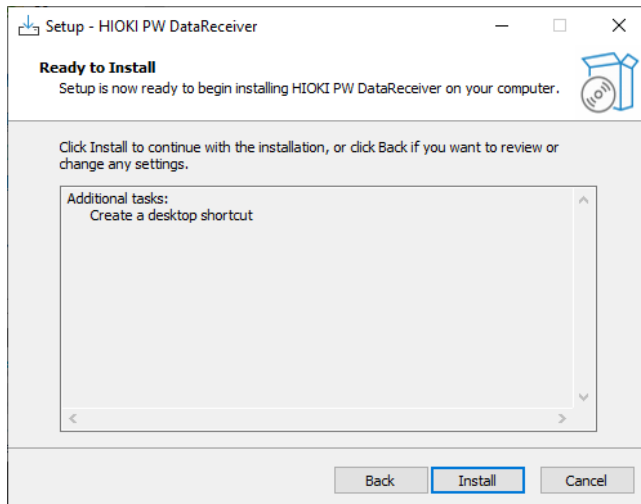

7 Click **[Finish]**.



That completes the installation process.

9.10 Controlling the Instrument and Acquiring Data Using Modbus/TCP Server Communications

Modbus is a communications protocol developed for use with programmable logic controllers (PLCs). You can acquire data and control connected devices through reading and writing registers. Communications using the TCP/IP protocol via Ethernet are called Modbus/TCP communications.

The instrument's Modbus/TCP communications function has a server function that responds to commands sent from connected external devices (client devices). This function enables real-time control of the instrument and acquisition of measurement data.

How to connect

Connect a LAN cable to the RJ-45 connector (Gigabit Ethernet) of the instrument to connect the instrument with a Modbus client equipment.

[Q See "9.2 LAN Connections and Settings" \(p.288\)](#)

Modbus specifications

Function	Modbus/TCP server
IPv4 address	IPv4 address presently set (To change and confirm settings, see "9.2 LAN Connections and Settings" (p.288).)
Port number	502 (fixed)
Server address	1 (fixed)
Related function codes	(0x03) Read holding register (0x04) Read input register (0X06) Write comment to holding register

For information about assigning registers, see the "Modbus/TCP Communications Instruction Manual".

9.11 Sending Measurement Data Via XCP on Ethernet

This instrument only supports the measurement mode of XCP on Ethernet and can be connected to higher-level tools that comply with the ASAM standard.

A LAN connection must be configured and connected to send measurement data via XCP on Ethernet. To establish an XCP connection, save instrument-specific settings file (A2L) on the PW4001 file screen. If instrument settings are changed after creating the A2L file, create and use a new A2L file.

Number of data items that can be sent via XCP (reference value)

This is only a reference value as it depends on environmental factors such as the network and computer on which the XCP master is operating.

Data update interval	No. of channels
1 ms	Not available
10 ms	1000
50 ms	4000
200 ms	20,000

How to connect

Connect a LAN cable to the RJ-45 connector (Gigabit Ethernet) of the instrument to connect the instrument with an XCP client device.

🔍 See “9.2 LAN Connections and Settings” (p.288)

Settings on the client software for ECU measurement and calibration

Load the A2L file created on the instrument, initialize and generate the DAQ list, and configure the data to be measured in the ODT entry. The DAQ list cannot be initialized or generated while the instrument is measuring.

IMPORTANT

- PW4001 measurement data is output to the XCP client in batches over a fixed period of time, making it unsuitable for real-time control.
- The instrument does not support the asynchronous uploading of measurement data.
- Calibration functions in XCP are not supported.
- If measurement items that cannot be calculated due to factors such as instrument unit configurations or wiring settings are configured on the client software for ECU measurement and calibration, the instrument will transmit an error value (77777.7E+30). Also, if an overload or peak-over occurs during measurement, the device will transmit an overflow value (99999.9E+30).

10 Specifications

10.1 General Specifications

Operating environment	Indoor use, pollution level 2, altitude up to 2000 m
Operating temperature and humidity range	-20°C to 50°C (-4°F to 122°F), 80% RH or less (non-condensing) When using below 0°C (32°F), pre-warm the device in an environment between 0°C and 50°C (32°F to 122°F) beforehand.
Storage temperature and humidity range	-20°C to 50°C (-4°F to 122°F), 80% RH or less (non-condensing)
Conforming standards	Safety: EN 61010 EMC: EN 61326 Class A
Complying standards (PW9006 option)	The instrument in IEC measurement mode complies with IEC 61000-4-7:2002 (Ed. 2.0). The instrument in IEC measurement mode complies with IEC 61000-4-15:2010 (Ed. 2.0).
Vibration resistance	JIS D 1601:1995 5.3 (1) Type 1: Passenger cars, Condition: Equivalent to Type A Vibration acceleration: 45 m/s ² (4.6 G) for 4 h in the X direction and 2 h in the Y and Z directions
Power supply	<ul style="list-style-type: none"> Commercial power supply Rated supply voltage: 100 to 240 V AC (Assuming voltage fluctuation of ±10%) Rated power-supply frequency: 50 Hz, 60 Hz Anticipated transient overvoltage: 2500 V Maximum rated power: 120 VA Typical power consumption (reference value): 47 W (Conditions: Power supply voltage of 100 V/60 Hz. Voltage of 800 V DC and current of 200 A DC (CT6834) measured on all channels.) <ul style="list-style-type: none"> DC power supply (optional) Rated supply voltage: 10.5 V to 28 V DC (Operating temperature range: -20°C to 40°C (-4°F to 104°F)) 10.5 V to 20 V DC (Operating temperature range: 40°C to 50°C (104°F to 122°F)) Maximum rated power: 95 VA
Backupbattery life	Lithium battery: About 10 years (Reference value at 23°C (73°F)) The battery is used to back up the time and setting conditions.
Dimensions	Approx. 361W × 176H × 135D mm (14.2"W × 6.9"H × 5.3"D) (excluding protruding parts)
Weight	Approx. 4.6 kg (10.1 lb.) (for PW4001-05)
Product warranty duration	3 years

10.1 General Specifications

Accuracy guarantee conditions	<p>Accuracy guarantee duration: 12 months (The accuracy guarantee duration for voltage, current, and power measurements, as well as for voltage accuracy of the motor analysis option, is 6 months. The 12-month accuracy is calculated by multiplying the reading error specified in each accuracy specification by 1.5.)</p> <p>Accuracy guarantee temperature and humidity range: 23°C ±3°C (73°F ±5°F), 80% RH or less</p> <p>Warm-up time: 30 minutes or longer</p> <p>Other conditions: Within the effective measurement ranges, sine waveforms or DC input, a line-to-earth voltage of 0 V, after zero adjustment has been performed and a change in ambient temperature does not exceed ±1°C after zero adjustment</p>
Accessories	🔍 See p.9
Options	🔍 See p.10

10.2 Specifications of Input, Output, and Measurement

Basic specifications

(1) Specifications common to voltage, current, and power measurement

Number of input channels	Voltage: 4 channels (U1 to U4) Current: 4 channels (I1 to I4)
Wiring configuration to be measured	Single-phase 2-wire (1P2W), single-phase 3-wire (1P3W), 3-phase 3-wire (3P3W2M, 3V3A, 3P3W3M), 3-phase 4-wire (3P4W)
Wiring configuration	Input channels can be assigned to any wiring channels. (However, only adjacent channels can be used in the same wiring configuration.) Different types of current sensors cannot coexist in the same wiring configuration.
Measurement method	Voltage/current simultaneous digital sampling with zero-crossing synchronized calculation
Sampling frequency, sampling bit rate	2.5 MHz, 16-bit
Frequency flatness	$\pm 0.1\%$ amplitude band: 50 kHz (typical) $\pm 0.1^\circ$ phase band: 100 kHz (typical)
Effective measurement range	Voltage, current, and active power For DC: 0% to 110% of the range For AC: 1% to 110% of the range
Effects of conducted radio-frequency electromagnetic field	For current and active power measurement, 6% of full scale or less at 10 V Current full scale means the sensor's rated current Active power full scale means the voltage range \times current sensor rating
Effects of radiated radio-frequency electromagnetic field	For current and active power measurement, 6% of full scale or less at 10 V/m Current full scale means the current sensor rating Active power full scale means the voltage range \times current sensor rating
Display range	 See "10.4 Detailed Specifications of Measurement Parameters" (p.358)
Measurement mode	<ul style="list-style-type: none"> Wideband measurement mode IEC measurement mode (PW9006 option)
Data update interval	1 ms, 10 ms, 50 ms, 200 ms The harmonic data update interval is specified separately. Average and user-defined operations are unavailable when the data update interval is set to 1 ms. In IEC measurement mode, the data update interval is fixed at approx. 200 ms (10 waves for 50 Hz measurement-frequency setting and 12 waves for 60 Hz).

10.2 Specifications of Input, Output, and Measurement

LPF	<p>Cutoff frequency f_c 500 Hz, 1 kHz, 5 kHz, 10 kHz, 50 kHz, 100 kHz, off</p> <p>Digital LPF Add $\pm 0.05\%$ of the reading to the accuracy except if the LPF is set to off. The accuracy specifications are specified for frequencies less than or equal to one tenth the set cutoff frequency. The peak value is based on the LPF-processed values, whereas the peak-over judgment uses not-digital-LPF processed values.</p>
Synchronization source	<p>U1 to U4, I1 to I4, DC (fixed at the data update interval for DC only)</p> <p>Models equipped with the motor analysis option Ext1 to Ext2: When the input settings of the following channels are set to Speed (pulse input) and the remainder left over when the pulse count is divided by half the number of poles is zero. Ext1: Ch. B, Ext2: Ch. D Zph1: When the Ch. D input setting is set to Origin (pulse input) Ch. B, Ch. D: When the corresponding channel enters [Individual input] operating mode</p> <ul style="list-style-type: none"> • Can be selected for each wiring configuration. (U and I of the same channel are measured in sync with the same synchronization source.) • The zero-crossing point of the waveform after passing through the zero-cross filter is used as the reference when U or I is selected. • In IEC measurement mode, only U or I can be selected.
Effective frequency range of synchronization source	DC, 0.1 Hz to 200 kHz
Effective input range of synchronization source	1% to 110% of the range
Zero-cross filter	<p>Used in zero-crossing detection for voltage and current waveforms. Does not affect measured waveforms. Consists of a digital LPF and HPF filters. Cutoff frequencies are automatically determined based on the settings of the measurement upper and lower frequency limits as well as measurement frequencies. HPF is selectable between on and off (fixed to off in IEC measurement mode).</p>
Lower measurement frequency limit	<p>Choose from the following frequency values for each wiring configuration: 0.1 Hz, 1 Hz, 10 Hz, 100 Hz, 1 kHz, 10 kHz, 100 kHz The frequency is fixed in IEC measurement mode. (It cannot be selected.)</p>
Upper measurement frequency limit	<p>Choose from the following frequency values for each wiring configuration: 100 Hz, 500 Hz, 1 kHz, 5 kHz, 10 kHz, 50 kHz, 100 kHz, 500 kHz, 1 MHz The frequency is fixed in IEC measurement mode. (It cannot be selected.)</p>
Polarity detection	Voltage/current zero-crossing timing comparison method
Measurement items	<p>Voltage (U), current (I), active power (P), apparent power (S), reactive power (Q), power factor (λ), phase angle (\varnothing), voltage frequency (fU), current frequency (fI), efficiency (η), loss (Loss), voltage ripple factor (Urf), current ripple factor (Irf), current integration (Ih), power integration (WP), voltage peak (Upk), current peak (Ipk)</p> <p> See "10.4 Detailed Specifications of Measurement Parameters" (p.358)</p>

(2) Specifications for voltage measurement

Input terminal profile	Plug-in terminal (safety terminal)
Input method	Isolated input, resistance voltage division
Range	6 V, 15 V, 30 V, 60 V, 150 V, 300 V, 600 V, 1500 V
Crest factor	3 relative to voltage range rating (however, 1.35 for 1500 V range)
Input resistance, input capacity	3 M Ω \pm 30 k Ω , 1 pF typical
Maximum input voltage	1000 V AC, 1500 V DC or \pm 2000 V peak
Maximum rated line-to-ground voltage	600 V AC, 1000 V DC in measurement category III, Anticipated transient overvoltage: 8000 V 1000 V AC, 1500 V DC in measurement category II, Anticipated transient overvoltage: 8000 V

(3) Specifications for current measurement

Input terminal profile	Dedicated connector (ME15W)	
Input method	Current sensor input method	
Range	<ul style="list-style-type: none"> Probe 1: Automatically recognizes the sensor's rated current 	
	40 mA, 80 mA, 200 mA, 400 mA, 800 mA, 2 A	With a 2 A sensor
	400 mA, 800 mA, 2 A, 4 A, 8 A, 20 A	With a 20 A sensor
	4 A, 8 A, 20 A, 40 A, 80 A, 200 A	With a 200 A sensor
	40 A, 80 A, 200 A, 400 A, 800 A, 2 kA	With a 2000 A sensor
	100 mA, 200 mA, 500 mA, 1 A, 2 A, 5 A	With a 5 A sensor
	1 A, 2 A, 5 A, 10 A, 20 A, 50 A	With a 50 A sensor
	10 A, 20 A, 50 A, 100 A, 200 A, 500 A	With a 500 A sensor
	100 A, 200 A, 500 A, 1 kA, 2 kA, 5 kA	With a 5000 A sensor
	20 A, 40 A, 100 A, 200 A, 400 A, 1 kA	With a 1000 A sensor
	<ul style="list-style-type: none"> CT9920: The sensor output rate can be selected 	
	40 mA, 80 mA, 200 mA, 400 mA, 800 mA, 2 A	1 V/A
	400 mA, 800 mA, 2 A, 4 A, 8 A, 20 A	100 mV/A
	4 A, 8 A, 20 A, 40 A, 80 A, 200 A	10 mV/A
	40 A, 80 A, 200 A, 400 A, 800 A, 2 kA	1 mV/A
	400 A, 800 A, 2 kA, 4 kA, 8 kA, 20 kA	0.1 mV/A
Selectable for each wiring (Only when the same sensors are used for all channels of the same wiring configuration)		
Crest factor	3 relative to voltage range rating	
Input resistance	1 M Ω \pm 50 k Ω	
Maximum input	8 V, \pm 12 V peak (10 ms or less)	

10.2 Specifications of Input, Output, and Measurement

Maximum number of connected channels	<p>Up to 4</p> <p>Up to three CT6877A, CT6876A, or CT6904A series current sensors can be connected when using an AC or DC power supply (power supply voltage: 10.5 V to 20 V) and with an operating temperature of 40°C to 50°C (104°F to 122°F).</p> <p>Up to three CT6877A, CT6876A, or CT6904A series current sensors can be connected when using a DC power supply (power supply voltage: 20 V to 28 V) and with an operating temperature of 30°C to 40°C (86 to 104°F).</p>
--------------------------------------	--

(4) Voltage, current, power accuracy specifications

Measurement accuracy for voltage, current, active power, and power phase angle

Accuracy	±[(% of the reading) + (% of the range)]	
	Voltage (U)	Current (I)
DC	0.03% + 0.01%	0.03% + 0.01%
0.1 Hz ≤ f < 30 Hz	0.10% + 0.20%	0.10% + 0.20%
30 Hz ≤ f < 45 Hz	0.10% + 0.10%	0.10% + 0.10%
45 Hz ≤ f ≤ 440 Hz	0.03% + 0.01%	0.03% + 0.01%
440 Hz < f ≤ 1 kHz	0.05% + 0.05%	0.05% + 0.05%
1 kHz < f ≤ 10 kHz	0.20% + 0.05%	0.20% + 0.05%
10 kHz < f ≤ 50 kHz	0.40% + 0.10%	0.40% + 0.10%
50 kHz < f ≤ 100 kHz	0.01 × f% + 0.2%	0.01 × f% + 0.2%
100 kHz < f ≤ 200 kHz	0.025 × f% + 0.3%	0.025 × f% + 0.3%
Frequency band	600 kHz (−3 dB typical)	600 kHz (−3 dB typical)

Accuracy	±[(% of the reading) + (% of the range)]	°
	Active power (P)	Power phase angle (∅) (Phase difference)
DC	0.03% + 0.01%	–
0.1 Hz ≤ f < 30 Hz	0.10% + 0.20%	±0.05°
30 Hz ≤ f < 45 Hz	0.10% + 0.10%	±0.05°
45 Hz ≤ f ≤ 440 Hz	0.03% + 0.01%	±0.05°
440 Hz < f ≤ 1 kHz	0.05% + 0.05%	±0.05°
1 kHz < f ≤ 10 kHz	0.20% + 0.05%	±0.20°
10 kHz < f ≤ 50 kHz	0.40% + 0.10%	±(0.02 × f) degrees
50 kHz < f ≤ 100 kHz	0.01 × f% + 0.2%	±(0.02 × f) degrees
100 kHz < f ≤ 200 kHz	0.025 × f% + 0.3%	±(0.02 × f) degrees

- In the expressions listed above, the unit “f” is kilohertz.
- DC values of voltage and current are specified by U_{dc} and I_{dc} .
Frequencies other than DC are specified by U_{rms} and I_{rms} .
- When U or I is selected as the synchronization source, accuracy is specified for a source input of at least 5% of the range.
- The power phase angle is specified for a power factor of zero during 100% input.

- For current, active power, and power phase angle, add the current sensor accuracy to the accuracy figures listed above.
- When $0.1 \text{ Hz} \leq f < 10 \text{ Hz}$, the accuracy figures for voltage, current, active power, and power phase angle are values for reference purposes.
- When $10 \text{ Hz} \leq f < 16 \text{ Hz}$, the accuracy figures for voltage, active power, and power phase angle over 220 V are values for reference purposes.
- When $16 \text{ Hz} < f \leq 30 \text{ kHz}$, the accuracy figures for voltage, active power, and power phase angle over 1000 V are reference values.
- When $30 \text{ kHz} < f \leq 100 \text{ kHz}$, the accuracy figures for voltage, active power, and power phase angle over 750 V are reference values.
- When $100 \text{ kHz} < f \leq 200 \text{ kHz}$, the accuracy figures for voltage, active power, and power phase angle over $(22000 / f \text{ [kilohertz]})$ volts are values for reference purposes.
- For the 6 V range, add $\pm 0.02\%$ of the range to the accuracy of voltage and active power.
- For the 15 V range, add $\pm 0.005\%$ of the range to the accuracy of voltage and active power.
- Add $\pm 0.02\%$ of the range to the accuracy of the current and active power for the 1/25 and 1/50 range of the current sensor rating.
- Add $\pm 0.01\%$ of the range to the accuracy of the current and active power for the 1/10 range of the current sensor rating.
- The effective measurement range of the current sensor (9272-05, CT7642, CT7742, CT7044, CT7045, CT7046) is between 0.5% of full scale and 100% of full scale.
- If a voltage is over 1000 V DC, add 0.05% of the reading to the DC accuracy for voltage and active power.
- When the input magnitude is between 100% of the range (exclusive) and 110% of the range (inclusive), multiply the range error by 1.1.
- If a voltage is over 600 V, add the following values to the power phase angle accuracy:

0.1 Hz < f ≤ 500 Hz: ±0.1°

500 Hz < f ≤ 5 kHz: ±0.3°

5 kHz < f ≤ 20 kHz: ±0.5°

20 kHz < f ≤ 200 kHz: ±1°

- Add the following value to the accuracy figures for voltage and active power if a voltage of 600 V or more is measured.
 $\pm(0.003 \times V^2)\%$ of the reading $\pm(1 \times V^2) \text{ mV}$ (V is input voltage [kV])
 Even when the voltage input value decreases, the effect of self-heating persists until the input resistance temperature drops. If the input voltage is over 900 V, other measurement channels (up to 600 V) will also have half the influence.
- If zero adjustment is performed with a warm-up time of less than 60 minutes, add $\pm 0.02\%$ of the range to the voltage, current, and active power accuracy.
- When the data update interval is 1 ms, add $\pm 0.1\%$ of the range to the voltage, current, and active power accuracy.
- Also see "Effects of temperature" (p.324).

Apparent power (S) measurement accuracy	(voltage accuracy) + (current accuracy) ±10 digits
---	--

10.2 Specifications of Input, Output, and Measurement

Reactive power (Q) measurement accuracy	For any condition except if $\varnothing = 0^\circ$ or $\pm 180^\circ$ (Apparent power accuracy) $\pm \{1 - \sin[\varnothing + (\text{Power phase angle accuracy})] / \sin \varnothing\} \times (100\% \text{ of the reading})$ $\pm [\sqrt{(1.001 - \lambda^2)} - \sqrt{(1 - \lambda^2)}] \times 100\% \text{ of range}$ For $\varnothing = 0^\circ$ and $\pm 180^\circ$ (Apparent power accuracy) $\pm [\sin(\text{Power phase angle accuracy})] \times (100\% \text{ of the range}) \pm (3.16\% \text{ of the range})$ The symbol λ designates the display value of the power factor.
Power factor (λ) measurement accuracy	For any condition except if $\varnothing = \pm 90^\circ$ $\pm \{1 - \cos[\varnothing + (\text{Power phase angle accuracy})] / \cos \varnothing\} \times (100\% \text{ of the reading}) \pm 50 \text{ digits}$ For $\varnothing = \pm 90^\circ$ $\pm \cos[\varnothing + (\text{Power phase angle accuracy})] \times (100\% \text{ of the range}) \pm 50 \text{ digits}$ The symbol \varnothing designates the display value of the power phase angle. Both of the above are specified at voltage/current range rating input.
Waveform peak measurement accuracy	Voltage and current RMS value accuracy $\pm 1\%$ of the range (300% of the range is applied as a peak range)
Effects of temperature	Add $\pm 0.005\%$ of the reading/ $^\circ\text{C}$ to the voltage, current, and active power accuracy within the range of -20°C to 20°C (-4°F to 68°F) or 26°C to 50°C (79°F to 122°F). Add $\pm 0.005\%$ of the range/ $^\circ\text{C}$ to DC accuracy of the voltage, current, and active power if a change in operating temperature range reaches or exceeds $\pm 1^\circ\text{C}$ ($\pm 2^\circ\text{F}$) after zero adjustment. For the 6 V range, add another $\pm 0.005\%$ of the reading/ $^\circ\text{C}$ to the DC accuracy of the voltage and active power.
Common-mode voltage rejection ratio (Effects of common-mode voltage)	50 Hz/60 Hz: 80 dB or more Specified for CMRR when the maximum input voltage is applied between the voltage input terminals and the enclosure for all measurement ranges.
Effects of external magnetic fields	$\pm 1\%$ of the range or less (in a magnetic field of 400 A/m, DC or 50 Hz/60 Hz)
Effects of the power factor on the active power	For any condition except if $\varnothing = \pm 90^\circ$ $\pm \{1 - \cos[\varnothing + (\text{Phase accuracy})] / \cos \varnothing\} \times (100\% \text{ of the reading})$ For $\varnothing = \pm 90^\circ$ $\pm \cos[\varnothing + (\text{Phase accuracy})] \times (100\% \text{ of VA})$

Specially Specified Combinatorial Accuracy With Optional Products for Current Measurement

For the following optional products for current measurement, the combinatorial accuracy with the PW4001 is specified specially.

For details, see “10.6 Specially Specified Combinatorial Accuracy With Optional Products for Current Measurement” (p.384) and specifications of optional products for current measurement.

Outline of the special combinatorial accuracy

Reading accuracy	Simple addition of the reading accuracy of the PW4001 and that of optional products for current measurement
Range accuracy	Simple addition of the range accuracy of the PW4001 and full-scale accuracy of optional products for current measurement (Regardless of the PW4001 range setting)

However, the above-listed combinatorial accuracy is specified only for DC and a frequency of between 45 Hz and 66 Hz (for some optional products for current measurement, 45 Hz and 65 Hz).

High accuracy, clamp

CT6841A	AC/DC Current Probe (20 A)
CT6843A	AC/DC Current Probe (200 A)
CT6833	AC/DC Current Probe (200 A)
CT6833-01	AC/DC Current Probe (200 A)
CT6834	AC/DC Current Probe (500 A)
CT6834-01	AC/DC Current Probe (500 A)
CT6844A	AC/DC Current Probe (500 A)
CT6845A	AC/DC Current Probe (500 A)
CT6846A	AC/DC Current Probe (1000 A)

High accuracy, pass-through

CT6872	AC/DC Current Sensor (50 A)
CT6872-01	AC/DC Current Sensor (50 A)
CT6873	AC/DC Current Sensor (200 A)
CT6873-01	AC/DC Current Sensor (200 A)
CT6904A	AC/DC Current Sensor (500 A)
CT6904A-1	AC/DC Current Sensor (500 A), Product manufactured on a per-order basis
CT6875A	AC/DC Current Sensor (500 A)
CT6875A-1	AC/DC Current Sensor (500 A)
CT6904A-2	AC/DC Current Sensor (800 A), Product manufactured on a per-order basis
CT6904A-3	AC/DC Current Sensor (800 A), Product manufactured on a per-order basis
CT6876A	AC/DC Current Sensor (1000 A)
CT6876A-1	AC/DC Current Sensor (1000 A)
CT6877A	AC/DC Current Sensor (2000 A)
CT6877A-1	AC/DC Current Sensor (2000 A)

High accuracy, direct wiring

PW9100A-3	AC/DC Current Box (50 A)
PW9100A-4	AC/DC Current Box (50 A)

(5) Frequency measurement specifications

Number of measurement channels	Up to 4 channels (fU1 to fU4, fI1 to fI4)
Measurement method	Reciprocal method The waveforms processed with the zero-cross filter are measured.

10.2 Specifications of Input, Output, and Measurement

Measurable range	0.1 Hz to 500 kHz (The display shows 0.00000 Hz or ----- Hz if measurement was not possible.) The range is limited by the measurement lower frequency limit setting.
Measurement accuracy	± 0.005 Hz (Assuming all the following conditions are met: Measurement parameter: voltage frequency, Data update interval: 50 ms or more, Voltage range: 15 V range or higher, Inputted waveform: a sine wave with a magnitude of at least 50% of the range, Frequency range: 45 Hz to 66 Hz) Under conditions other than listed above: $\pm 0.05\%$ of the reading (With a sine wave at least 30% of the measurement range of the measurement source. However, add $\pm 0.05\%$ of the reading for the data update interval of 1 ms.)
Display resolution	0.10000 Hz to 9.99999 Hz, 9.9000 Hz to 99.9999 Hz, 99.000 Hz to 999.999 Hz, 0.99000 kHz to 9.99999 kHz, 9.9000 kHz to 99.9999 kHz, 99.000 kHz to 999.999 kHz

(6) Integration measurement specifications

Measurement mode	Can be chosen between RMS and DC for each wiring. (The DC mode is selectable for the 1P2W wiring configuration only.)
Measurement items	Current integration (Ih+, Ih-, Ih), Active power integration (WP+, WP-, WP) The instrument measures Ih+ and Ih- only in DC mode; Ih only in RMS mode.
Measurement method	Digital calculation based on current and active power. (Calculations are performed using not-averaged values during averaging.) In DC mode: Integrates current values and instantaneous power values for each polarity at every sampling point. In RMS mode: Integrates current RMS values and active power values at the measurement intervals. Only the active power is integrated by polarity. (Active power is integrated by polarity at every period of the synchronization source.) (The sum of integrated active power values of a polyphase wiring configuration is the sum of effective power values by polarity at the measurement intervals.)
Measurement interval	Same as the data update interval
Display resolution	999999 (6 digits + decimal point), Starts from the resolution assuming 1% of each range to be 100% of the range.
Measurable range	0 Ah/Wh to ± 99.9999 PAh/PWh
Integration time	0 s to 9999 h 59 min. 59 s Integration stops if the integration time exceeds the range.
Integration time accuracy	$\pm 0.02\%$ of the reading (-20°C to 50°C [-4°F to 122°F])
Integration accuracy	$\pm(\text{Current or active power}) \pm(\text{Integration time accuracy})$
Backup function	None If a power outage occurs during integration, the integration stops after power is restored and the integration data is reset.

Integration control	<p>All-channel synchronized integration:</p> <ul style="list-style-type: none"> • Manual (keys, communications commands, external) control: Start, stop, data reset • Real time control: Start, stop • Timer control: Stop after a lapse of the set time. <p>Configuration-specific independent integration: (No data will be saved.) (Unavailable in IEC measurement mode and during BNC synchronization)</p> <ul style="list-style-type: none"> • Manual (keys, communications commands, external) control: Start, stop, and data reset by the wiring configuration • Real time control: Start and stops by the wiring configuration • Timer control: Stop by the wiring configuration after a specified time <p>Cumulative integration available (Restarting after integration stop is available. Integration resumes, adding values to the previous integrated values.)</p> <p>Unavailable in IEC measurement mode (restart not possible)</p>
---------------------	---

(7) Specifications common to harmonic measurement

Number of measurement channels	Up to 4
Synchronization source	<p>Same as those specified in the basic measurement specifications.</p> <p>Based on the synchronization source setting of the voltage, current, and power measurement selected for each wiring configuration.</p> <p>However, for the wiring configuration with Zph1 respectively selected as the synchronization source of the voltage, current, and power measurement, you can choose whether harmonic measurement is in sync with Ext1 or in sync with Zph1.</p>
Measurement mode	Selectable between wideband measurement mode (PW9006 option) and IEC measurement mode (setting common to all channels)
Measurement items	<p>Harmonic voltage RMS value, harmonic voltage content percentage, harmonic voltage phase angle, harmonic current RMS value, harmonic current content percentage, harmonic current phase angle, harmonic active power, harmonic power content percentage, harmonic voltage-vs.-current phase difference, total harmonic voltage distortion, total harmonic current distortion, voltage unbalance rate, current unbalance rate</p> <p>(Only in IEC measurement mode)</p> <p>Inter-harmonic voltage RMS value, inter-harmonic current RMS value</p>
FFT processing word length	32 bits
Anti-aliasing	Digital filter (automatically set based on synchronization frequency)
Window function	Rectangular
Grouping	Off, Type 1 (harmonic sub-group), Type 2 (harmonic group) (Setting common to all channels)
THD calculation method	<p>THD_F, THD_R</p> <p>Select the calculation order from between 2nd and 500th. (However, limited to the maximum analysis order of each mode.)</p> <p>(Setting common to all channels)</p>

(8) Specifications of IEC-compliant harmonic measurement in IEC measurement mode (PW9006 option)

Measurement method	Compliant with IEC 61000-4-7:2002 (Ed. 2.0), without gaps or overlaps
Measurement frequency setting	50 Hz/60 Hz
Synchronization frequency range	For 50 Hz setting: 45 Hz to 55 Hz For 60 Hz setting: 56 Hz to 66 Hz
Data update interval	Fixed at approx. 200 ms (10 waves for 50 Hz measurement-frequency setting; 12 waves for 60 Hz)
Analysis order	Harmonics: 0th to 200th orders Inter-harmonic: 0.5th to 200.5th orders
Window wave number	10 waves for 50 Hz measurement-frequency setting; 12 waves for 60 Hz
Number of FFT points	8192 points
Measurement accuracy	Add $\pm 0.04\%$ of the range to the following measurement accuracy within the synchronous frequency range of each frequency setting: voltage, current, and power. For a frequency of 10 kHz or more, add another $\pm 0.04\%$ of the range.

(9) Specifications of wideband harmonic measurement in wideband measurement mode

Measurement method	Zero-crossing sync calculation method (the same window for each synchronization source), with gaps Fixed sampling interpolation calculation method		
Synchronization frequency range	0.1 Hz to 600 kHz		
Data update interval	Fixed at 50 ms. When it is set to 10 ms, only harmonic data is updated at 50 ms intervals. When it is set to 200 ms, values are obtained by averaging four sets of 50 ms data.		
Maximum analysis order and the window wave number	Fundamental wave frequency	Window wave number	Maximum analysis order
	$0.1 \text{ Hz} \leq f \leq 2 \text{ kHz}$	1	500th
	$2 \text{ kHz} < f \leq 5 \text{ kHz}$	1	300th
	$5 \text{ kHz} < f \leq 10 \text{ kHz}$	2	150th
	$10 \text{ kHz} < f \leq 20 \text{ kHz}$	4	75th
	$20 \text{ kHz} < f \leq 50 \text{ kHz}$	8	30th
	$50 \text{ kHz} < f \leq 100 \text{ kHz}$	16	15th
	$100 \text{ kHz} < f \leq 200 \text{ kHz}$	32	7th
	$200 \text{ kHz} < f \leq 300 \text{ kHz}$	64	5th
	$300 \text{ kHz} < f \leq 500 \text{ kHz}$	128	3rd
	$500 \text{ kHz} < f \leq 600 \text{ kHz}$	256	1st

Phase zero-adjustment function	<p>Phase zero-adjustment can be started by using keys or communications commands. (Only available when the synchronization source is set to Ext) Phase zero-adjustment values can be set automatically or manually. Valid setting range of the phase zero-adjustment: 0.000° to ±180.000° (in 0.001° increments)</p>																				
Number of FFT points	Automatically selected from among 2048, 4096, and 8192 points.																				
Measurement accuracy	<p>Add the following values to the voltage, current, power, and phase difference accuracy. When the fundamental frequency is 100 Hz or more, add another ±0.1% of the range to the following voltage, current, and power accuracies, and add ±0.1° to the phase difference accuracy. When the fundamental frequency is 2 kHz or more, add another ±0.05% of the reading and ±0.1% of the range to the following voltage, current, and power accuracies, and add ±0.1° to the phase difference accuracy.</p>																				
	<table border="1" data-bbox="448 651 1428 1048"> <thead> <tr> <th data-bbox="448 651 839 734">Frequency</th> <th data-bbox="839 651 1134 734">Voltage, current, power ±(% of the reading)</th> <th data-bbox="1134 651 1428 734">Phase difference ±(°)</th> </tr> </thead> <tbody> <tr> <td data-bbox="448 734 839 786">DC</td> <td data-bbox="839 734 1134 786">0.05%</td> <td data-bbox="1134 734 1428 786">–</td> </tr> <tr> <td data-bbox="448 786 839 837">0.1 Hz ≤ f ≤ 100 Hz</td> <td data-bbox="839 786 1134 837">0.01%</td> <td data-bbox="1134 786 1428 837">0.1°</td> </tr> <tr> <td data-bbox="448 837 839 889">100 Hz < f ≤ 1 kHz</td> <td data-bbox="839 837 1134 889">0.03%</td> <td data-bbox="1134 837 1428 889">0.1°</td> </tr> <tr> <td data-bbox="448 889 839 940">1 kHz < f ≤ 10 kHz</td> <td data-bbox="839 889 1134 940">0.08%</td> <td data-bbox="1134 889 1428 940">0.6°</td> </tr> <tr> <td data-bbox="448 940 839 992">10 kHz < f ≤ 50 kHz</td> <td data-bbox="839 940 1134 992">0.15%</td> <td data-bbox="1134 940 1428 992">(0.020 × f) ±0.5°</td> </tr> <tr> <td data-bbox="448 992 839 1043">50 kHz < f ≤ 200 kHz</td> <td data-bbox="839 992 1134 1043">0.20%</td> <td data-bbox="1134 992 1428 1043">(0.030 × f) ±2.0°</td> </tr> </tbody> </table> <ul data-bbox="448 1070 1439 1456" style="list-style-type: none"> • In the expressions listed above, the unit of frequency (f) is kilohertz (kHz). • The figures for voltage, current, power, and phase difference for frequencies over 200 kHz are values for reference purposes. • When the fundamental wave has a frequency within the range of 16 Hz to 850 Hz, the figures for voltage, current, power, and phase difference over 6 kHz are values for reference purposes. • When the fundamental wave has a frequency outside the range of 16 Hz to 850 Hz, the figures for voltage, current, power, and phase difference for frequencies other than the fundamental wave are values for reference purposes. • Accuracy values for phase difference are specified for input with the voltage and current of the same order that have an amplitude of at least 10% of the range. 	Frequency	Voltage, current, power ±(% of the reading)	Phase difference ±(°)	DC	0.05%	–	0.1 Hz ≤ f ≤ 100 Hz	0.01%	0.1°	100 Hz < f ≤ 1 kHz	0.03%	0.1°	1 kHz < f ≤ 10 kHz	0.08%	0.6°	10 kHz < f ≤ 50 kHz	0.15%	(0.020 × f) ±0.5°	50 kHz < f ≤ 200 kHz	0.20%
Frequency	Voltage, current, power ±(% of the reading)	Phase difference ±(°)																			
DC	0.05%	–																			
0.1 Hz ≤ f ≤ 100 Hz	0.01%	0.1°																			
100 Hz < f ≤ 1 kHz	0.03%	0.1°																			
1 kHz < f ≤ 10 kHz	0.08%	0.6°																			
10 kHz < f ≤ 50 kHz	0.15%	(0.020 × f) ±0.5°																			
50 kHz < f ≤ 200 kHz	0.20%	(0.030 × f) ±2.0°																			

Specifications of waveform recording

Measurement channels	Voltage and current waveforms: Up to 4 channels (up to 8 waveforms can be displayed) Motor waveform: Up to 2 analog DC channels + up to 4 pulse channels
Recording capacity	(5 megawords) × [(Number of measured items, including voltage and current) × (Number of channels, up to 4) + (Number of motor waveforms)] No memory segmentation function
Waveform resolution	16-bit
Sampling speed	<ul style="list-style-type: none"> Voltage and current waveform Motor waveform (analog DC) (1 MS/s is interpolated with 0th held when 2.5 MS/s of data is sampled.) Motor waveform (pulse) 2.5 MS/s, 1.0 MS/s, 500 kS/s, 250 kS/s, 100 kS/s, 50 kS/s, 25 kS/s, 10 kS/s
Recording length	1 kiloword, 5 kilowords, 10 kilowords, 50 kilowords, 100 kilowords, 500 kilowords, 1 megaword, 5 megawords
Storage mode	Peak-to-peak compression
Trigger mode	Single, normal (auto-trigger setting available)
Pre-trigger	0% to 100% of the recording length, in 10 percent increments
Trigger detection method	<ul style="list-style-type: none"> Level trigger (detects triggers based on fluctuations in the level of storage waveforms) Trigger source: Voltage and current waveforms, voltage and current waveforms processed by the zero-cross filter, manual trigger, motor waveform, motor pulse Trigger slope: Rising edge, falling edge Trigger level: ±300% of the range for waveforms in 0.1 percent increments Event trigger Triggers are detected based on fluctuations in the values of basic measurement items. The trigger-detecting conditions are determined based on the logical OR and AND of the following four events. The logical AND takes precedence over the logical OR. Events: Composed of basic measurement items, inequality signs (<, >), and numerical values (0 to ±99999.9T). Ev n: Item □ X.XXXXX y (n: 1 to 4, Item: basic measurement item, □: inequality sign, X.XXXXX: six-digit constant, y: SI prefix)

Specifications of flicker measurement (PW9006 option)

Measurement channels	Up to 4
Measurement method	Compliant with IEC 61000-4-15:2010 (Ed. 2.0) Flickermeter Class F1
Measurement items	Short-term flicker (Pst) Maximum short-term flicker value (PstMax) Long-term flicker value (Plt) Maximum instantaneous flicker value (PinstMax) Minimum instantaneous flicker value (PinstMin) Relative steady-state voltage change (dc) Maximum relative voltage change (dmax) Period during which the relative voltage change exceeds the threshold (Tmax)
Measurement frequency	50 Hz, 60 Hz (measurable in IEC measurement mode only)
Measurement range	Pst, Plt: 0.0001 P.U. to 6400 P.U. (logarithmic 1400-way split)
Flicker filter	230 V lamp, 120 V lamp
Measurement accuracy	dc, dmax: $\pm 4\%$ (at a dmax of 4%) Pst: $\pm 5\%$ (Pst = 0.2 to 5)

Specifications of motor analysis (optional)

(1) Specifications common to analog DC input, frequency input, and pulse input

Number of input channels	4 channels																			
	Channel	Input parameter																		
	Ch. A, Ch. C	Analog DC, frequency, pulse																		
	Ch. B, Ch. D	Frequency, pulse																		
Operating mode	<ul style="list-style-type: none"> Motor analysis mode <table border="1"> <thead> <tr> <th></th> <th>Measurement or detection item (input type)</th> <th>Maximum number of analysis parameters</th> </tr> </thead> <tbody> <tr> <td>Pattern 1</td> <td>Torque (analog/frequency), speed (pulse)</td> <td>2 motors</td> </tr> <tr> <td>Pattern 2</td> <td>Torque (analog/frequency), speed (pulse), direction, origin (pulse)</td> <td>1 motor</td> </tr> <tr> <td>Pattern 3</td> <td>Torque (analog/frequency), speed (pulse), direction</td> <td>1 motor</td> </tr> <tr> <td>Pattern 4</td> <td>Torque (analog/frequency), speed (pulse), origin (pulse)</td> <td>1 motor</td> </tr> <tr> <td>Pattern 5</td> <td>Torque (analog/frequency), speed (analog)</td> <td>1 motor</td> </tr> </tbody> </table> <ul style="list-style-type: none"> Individual input mode <p>Ch. A, Ch. C: DC voltage measurement, frequency measurement Ch. B, Ch. D: Frequency measurement</p>			Measurement or detection item (input type)	Maximum number of analysis parameters	Pattern 1	Torque (analog/frequency), speed (pulse)	2 motors	Pattern 2	Torque (analog/frequency), speed (pulse), direction, origin (pulse)	1 motor	Pattern 3	Torque (analog/frequency), speed (pulse), direction	1 motor	Pattern 4	Torque (analog/frequency), speed (pulse), origin (pulse)	1 motor	Pattern 5	Torque (analog/frequency), speed (analog)	1 motor
		Measurement or detection item (input type)	Maximum number of analysis parameters																	
	Pattern 1	Torque (analog/frequency), speed (pulse)	2 motors																	
	Pattern 2	Torque (analog/frequency), speed (pulse), direction, origin (pulse)	1 motor																	
	Pattern 3	Torque (analog/frequency), speed (pulse), direction	1 motor																	
	Pattern 4	Torque (analog/frequency), speed (pulse), origin (pulse)	1 motor																	
	Pattern 5	Torque (analog/frequency), speed (analog)	1 motor																	
Input terminal profile	Isolated BNC connector																			
Input method	Function-isolated input and single-end input Between-channels function isolation																			
Input resistance (DC)	1 MΩ ±50 kΩ																			
Maximum input voltage	20 V																			
Maximum rated line-to-ground voltage	30 V (50 Hz/60 Hz)																			
Measurement items	Voltage, torque, RPM, frequency, slip, motor power																			
Synchronization source	<p>Same as those specified in the basic measurement specifications (The effective frequency range and effective input range are also the same.) (However, there are no restrictions in IEC measurement mode.)</p> <ul style="list-style-type: none"> In motor analysis mode <ul style="list-style-type: none"> Pattern 1: Two types, for Ch. A and Ch. B as well as Ch. C and Ch. D, can be set in [A-D]. Pattern 2 to Pattern 5: One type can be set in each of [A-D]. In individual input mode <ul style="list-style-type: none"> Two types, for Ch. A and Ch. B as well as Ch. C and Ch. D, can be set in [A-D]. 																			

Lower measurement frequency limit	Select from among the following frequency values for each motor synchronization source: 0.1 Hz, 1 Hz, 10 Hz, 100 Hz
Upper measurement frequency limit	Select from among the following frequency values for each motor synchronization source: 100 Hz, 500 Hz, 1 kHz, 5 kHz, 10 kHz, 50 kHz, 100 kHz, 500 kHz, 1 MHz, 2 MHz
Input frequency source	Selectable between fU1 to fU4 and fI1 to fI4. The frequency for slip calculation can be set.
Number of motor poles	2 to 254
Z-phase pulse detection reference	The reference for detecting Zph of the synchronization source can be set in operating mode 2 or 4. Rising edge, falling edge

(2) Analog DC input specifications (Ch. A, Ch. C)

Measurement range	1 V, 5 V, 10 V
Crest factor	1.5
Effective input range	1% to 110% of the range
Sampling frequency, sampling bit rate	1 MHz, 16-bit
LPF	1 kHz, off (20 kHz)
Response speed	0.2 ms (when the LPF is disabled)
Measurement method	Simultaneous digital sampling, zero-crossing synchronization calculation method (Between-zero-crossing averaging)
Measurement accuracy	$\pm 0.03\%$ of the reading $\pm 0.03\%$ of the range
Effects of temperature	Add $\pm 0.005\%$ of the reading/ $^{\circ}\text{C}$ within the range of -20°C to 20°C (-4°F to 68°F) or 26°C to 50°C (79°F to 122°F). Also, add $\pm 0.005\%$ of the range/ $^{\circ}\text{C}$ for temperature changes of $\pm 1^{\circ}\text{C}$ ($\pm 2^{\circ}\text{F}$) or more after zero adjustment.
Effects of common-mode voltage	$\pm 0.01\%$ of the range or less When a voltage of 30 V (DC, 50 Hz/60 Hz) is applied between the input terminals and the enclosure
Effects of external magnetic fields	$\pm 0.1\%$ of the range or less (in a magnetic field of 400 A/m, DC or 50 Hz/60 Hz)
Display range	 See "(4) Motor analysis measurement items (only when the motor analysis option is installed)" (p.362) in "10.4 Detailed Specifications of Measurement Parameters" (p.358)
Scaling	For torque: ± 0.01 to 9999.99 For RPM: ± 0.00001 to 99999.9
Zero adjustment	Scaled input offsets less than or equal to $\pm 10\%$ of the range are compensated for to zero. When the torque meter correction is enabled, input offsets are compensated to zero after adding the calibration values.

10.2 Specifications of Input, Output, and Measurement

Torque meter correction	<p>Off/on (selectable by motor)</p> <ul style="list-style-type: none"> • Nonlinearity correction Torque values are corrected using an 11-point (at a maximum) correction table of torque calibration points (N•m) vs. torque calibration values (N•m). • Friction correction Torque values are corrected using an 11-point (at a maximum) correction table of RPM values (r/min.) with consideration of rotation directions vs. torque calibration values (N•m). <p>Each interval between torque calibration values is linearly interpolated. The unit for the correction table depends on the setting. Enter a 6-digit calibration value. The signs of torque calculation are used for detecting rotation directions: forward (plus sign) and backward (minus sign).</p>
Torque calculation and correction	<p>When disabled: (Torque value) = S × [X - (Zero-correction value)] When enabled: (Torque value) = S × [X - (Zero-correction value)] - At - Bt</p> <p>S:Scaling X: Input signal-to-torque converted value At: Nonlinearity correction value Bt: Friction correction value</p>

(3) Frequency input specifications (Ch. A, Ch. B, Ch. C, Ch. D)

Detection level	Low: approx. 0.8 V or less; High: approx. 2.0 V or more
Measurement frequency band	0.1 Hz to 2 MHz (when the duty ratio is set at 50%)
Minimum detection width	0.25 μs or more
Measurement range	<p>The zero-point frequency f_c and frequency f_d at rated torque in $f_c \pm f_d$ (Hz) can be set. Set f_c and f_d using 7-digit figures in the range of 1 kHz to 500 kHz. However, values must be set so that both the inequalities $(f_c + f_d) \leq 500$ kHz and $(f_c - f_d) \geq 1$ kHz are met.</p>
Measurement accuracy	<p>±0.01% of the reading When the data update interval is set to 1 ms, add ±0.01% of the reading to the measuring accuracy.</p>
Display range	1.000 kHz to 500.000 kHz
Scaling	±0.01 to 9999.99
Zero adjustment	<p>Offsets of input within the range of $f_c \pm 1$ kHz can be compensated to zero. When the torque meter correction is enabled, calibration values are added to compensate for offsets to zero.</p>
Unit	mN•m, N•m, kN•m

Torque meter correction	<p>Off/on</p> <ul style="list-style-type: none"> Nonlinearity correction Torque values are corrected using an 11-point (at a maximum) correction table of torque calibration points (N•m) vs. torque calibration values (N•m). Friction correction Torque values are corrected using the 11-point (at a maximum) correction table of RPM values (r/min.) with consideration of rotation directions vs. torque calibration values (N•m). <p>Each interval between torque calibration values is linearly interpolated. The unit for the correction table depends on the setting. Enter a 6-digit calibration value. The signs of torque calculation are used for detecting rotation directions: forward (plus sign) and backward (minus sign).</p>
Torque calculation and correction	<p>When disabled: (Torque value) = S × [X - (Zero-correction value)] When enabled: (Torque value) = S × [X - (Zero-correction value)] - At - Bt</p> <p>S: Scaling X: Input signal-to-torque converted value At: Nonlinearity correction value Bt: Friction correction value</p>

(4) Pulse input specifications (Ch. A, Ch. B, Ch. C, Ch. D)

Detection level	Low: approx. 0.8 V or less; High: approx. 2.0 V or more
Measurement frequency band	0.1 Hz to 2 MHz (when the duty ratio is set at 50%)
Minimum detection width	0.25 μs or more
Pulse-noise filter (PNF)	Off, weak, strong (positive/negative pulses of less than 0.25 μs are ignored with the weak setting, as are those less than 5 μs with the strong setting)
Measurement range	2 MHz
Measurement accuracy	±0.01% of the reading When the data update interval is set to 1 ms, add ±0.01% of the reading to the measuring accuracy.
Display range	0.1 Hz to 2.00000 MHz
Unit	Hertz (Hz), revolutions per minute (r/min.)
Frequency division setting range	±1 to 60000
Rotation direction detection	Individually settable in [A-D] Pattern 2 to Pattern 5 of motor analysis mode Detects direction based on lead/lag of Ch. B and Ch. C in [A-D] .
Mechanical angle origin detection	Individually settable in [A-D] Pattern 2 to Pattern 5 of motor analysis mode Ch. B frequency division is cleared at the Ch. D rising or falling edge in [A-D] .

Specifications of waveform and D/A output (optional)

Number of output channels	16 channels
Output terminal profile	D-sub 25-pin connector × 1
Output details	Switchable between waveform output and analog output (selectable from basic measurement items except the flicker measurement items)
D/A conversion resolution	16-bit (polarity + 15 bits)
Output update interval	Waveform output: 1 MHz Analog output: 1 ms, 10 ms, 50 ms, 200 ms (depending on data update intervals of selected items, with an error of ±1 ms)
Output voltage	Waveform output: Switchable between ±2 V f.s. and ±1 V f.s., crest factor: 2.5 or more The settings affect all channels. Analog output: ±5 V DC f.s. (approx. up to ±12 V DC)
Maximum output voltage	Approx. ±12 V
Output resistance	100 Ω ± 5 Ω
Output accuracy	Waveform output: Add ±0.5% f.s. to measurement accuracy with the ±2 V f.s. setting. Add ±1.0% f.s. to measurement accuracy at the ±1 V f.s. setting. Specified assuming DC to 50 kHz output. Analog output: Add ±0.2% f.s. to the measurement accuracy of output measurement items (DC level).
Temperature coefficient	±0.05% f.s./°C

Pin assignment

Pin No.	Output	Pin No.	Output
1	GND	14	GND
2	D/A1	15	D/A13
3	D/A2	16	D/A14
4	D/A3	17	D/A15
5	D/A4	18	D/A16
6	D/A5	19	GND
7	D/A6	20	GND
8	D/A7	21	GND
9	D/A8	22	GND
10	D/A9	23	GND
11	D/A10	24	GND
12	D/A11	25	GND
13	D/A12		

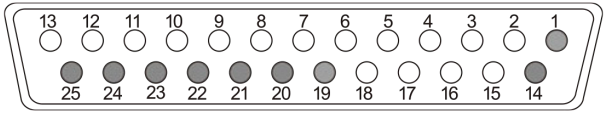

Display specifications

Display language	Japanese, English, Simplified Chinese, Traditional Chinese
Display	10.1" WXGA TFT color LCD (1280 × 800 dots)
Dot pitch	0.1695 (V) mm × 0.1695 (H) mm
Display value resolution	999999 count (including integrated values)
Display update interval	Measured values: Approx. 200 ms (independent of internal data update interval) Waveforms: Based on waveform recording settings
Screen	Measurement screen, Input Settings screen, System Settings screen, File Operation screen
Warning display	When an input-channel voltage or current peak-over condition is detected, when no synchronization source is detected. Warning icons for all channels will be displayed on any page of the screen.

Specifications of operating parts

Control device	Power button ×1, rubber keys ×23, rotary knobs ×2, touchscreen
Touchscreen	Analog resistive film
Rotary knob	30 notches, 15 pulses, lamp-equipped
Keys	Mechanical switch type, lamp-equipped ×12, no-lamp-equipped ×12 <ul style="list-style-type: none"> Lamp-equipped <p>Green: MEAS, INPUT, SYSTEM, FILE, AUTO ×2, SINGLE</p> <p>Red: HOLD, PEAK HOLD, REMOTE/LOCAL</p> <p>Red/green: START/STOP, RUN/STOP</p> No-lamp-equipped: <p>Pages (left and right), SAVE, SCREEN SHOT, U-UP, U-DOWN, I-UP, I-DOWN, 0 ADJ, DATA RESET, MANUAL, POWER</p>
Key lock	Holding down the REMOTE/LOCAL key for 3 s can turn the key lock on/off. While the key lock is engaged, the key lock icon is displayed on the screen.
System reset	The instrument setting is reset to the initial state. However, the language and communications settings are not reset.
Boot-key reset	The instrument's settings are reverted to their factory defaults if the instrument is turned on while the SYSTEM key is held down. All settings, including the language and communications settings, are reverted to their factory defaults.
File operation	Displaying data list stored on a USB flash drive, formatting a USB flash drive, creating new folders, renaming folders/files, copying/deleting files, updating the firmware, displaying screenshots, creating/loading settings files

External interface specifications

(1) USB flash drive

Connector	USB Type A receptacle connector × 1
Standard/method	USB 3.0 (Super Speed)
Device to be connected	USB flash drive
Data to be recorded on USB flash drives	Saving/loading settings files Saving measured values and automatically recorded data Saving waveform data and screenshots

(2) LAN

Connector	RJ-45 connector × 1
Standard/method	IEEE 802.3 compliant
Transmission method	100Base-TX, 1000Base-T (automatic detection)
Protocol	TCP/IP (with DHCP function)
Function	HTTP server (remote operation) Dedicated port (data transfer, command control) FTP server (file transfer) FTP client Modbus/TCP server XCP on Ethernet (compliant with ASAM e.V.MCD-1 v 1.5.0)
Recommended cable	Category 6A or higher STP cable, maximum cable length: 5 m

(3) USB (function)

Connector	Series Mini B receptacle × 1
Electrical specifications	USB2.0 (Full Speed / High Speed)
Class	Proprietary (USB488h)
Connected device	Computer (Windows 10 (32-bit, 64-bit) / Windows 11 (64-bit))
Function	Data transfer, command control, USB mass storage LAN cannot be used simultaneously. If connected simultaneously, the USB connection will take priority. Operation and communication are not possible during USB mass storage

(4) External control

Connector	4-terminal screwless terminal block × 1
Pin assignment	No. 1 pin: Ground No. 2 pin: Data reset No. 3 pin: Hold No. 4 pin: Start/stop
Electrical specifications	Logic signal of 0 / 5 V (2.5 V to 5 V) or contact signals by shorting/opening the terminal

Maximum input voltage	5.5 V
Function	Same operation as the START/STOP key, DATA RESET key, or HOLD key on the control panel

(5) BNC synchronization

Connector	BNC
Number of instruments that can be synchronized	8 (one primary and seven secondary)
Function	<p>Primary instrument Transmitting control signals to secondary instruments</p> <p>Secondary instruments Synchronizing the following functions and operations with those of the primary instrument</p> <ul style="list-style-type: none"> • Timing of internal calculations and data updating • Starting and stopping integration and resetting integration data • Freezing displays (HOLD/PEAK HOLD) and updating data during the display freeze • Zero adjustment • Operating the instrument using the SAVE and SCREEN SHOT keys • Present time (Synchronizable items cannot be controlled; their settings cannot be change during synchronization) <p>The primary and secondary instruments can synchronize only when they have the same settings of the measurement mode and data update interval; those with a data update interval of 10 ms or less cannot.</p>

(6) CAN/CAN FD

Protocol	CAN (classical) CAN FD (in conformity with ISO 11898-1:2015) CAN FD (not in conformity with ISO)
Function	Data output Data input
CAN port	1 port
Number of installed modules	1
CAN transceiver	MCP2544 FD

10.2 Specifications of Input, Output, and Measurement

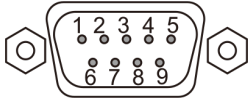
Communication connector	D-sub 9-pin connector (male)			
	Locking screw (hexagonal pillar): Inch screw #4-40 UNC			
	Pin assignment			
				
	Pin	Assignment	I/O	Function
	1	N.C.	-	Unused
	2	CAN_L	OUT	CAN_Low communication line
	3	GND	-	GND
	4	N.C.	-	Unused
	5	Shield	-	Shield (internally connected to GND)
6	N.C.	-	Unused	
7	CAN_H	OUT	CAN_High communication line	
8	N.C.	-	Unused	
9	N.C.	-	Unused	

Common data I/O settings		
Baud rate	CAN:	125 k, 250 k, 500 k, 1 Mbps
	CAN FD: (The baud rate options are common to the following two CAN FD protocols: ISO-compliant and ISO-non-compliant.)	Arbitration area: 500 k, 1 Mbps Data area: 500 k, 1 M, 2 M, 4 Mbps
Sample point setting	0.0% to 99.9%	
Terminal resistance	ON/OFF Resistance value: 120 Ω ±10 Ω	
ISO15765-2	ON/OFF	
CAN communication	ON/OFF	
Data output settings		
Data frame output	Continuous	

Continuous	Output interval:	<p>1 ms, 10 ms, 50 ms, 100 ms, 200 ms, 500 ms, 1 s, 5 s, 10 s, 15 s, 30 s, 1 min, 5 min, 10 min, 15 min, 30 min, 60 min With an error of ± 1 ms from each data update interval setting However, the interval cannot be set to less than the data update interval. The output interval of 500 ms is unavailable with the data update interval of 200 ms. In IEC measurement mode, the output intervals of 100 ms and 500 ms are available with the data update interval of 200 ms.</p>	
	Repeated output count:	0 to 10000 (0: infinite)	
Format	Standard, extended		
Setting ID	Standard format:	0x000 to 0x7FF	
	Extended format:	0x00000000 to 0x1FFFFFFF	
Output parameters	See "Output parameters" (p.344)		
Data conversion	Measured data:	Floating-point type (IEEE Float: 4 bytes)	
	Output count, output time:	Unsigned integer	
Byte order (Endianness)	Intel (little-endian)		
Data input settings			
Number of receiving channels	Up to 20		
Receiving channel definition	Format:	Standard / extended	
	ID:	Standard format	0x000 to 0x7FF
		Extended format	0x00000000 to 0x1FFFFFFF
	Name		
	Unit		
	Factor / offset		
	Start bit:	0 to 5119 (bit)	
	Bit length:	1 to 64 (bits)	
	Data type:	Unsigned integer/signed integer/single-precision floating-point/double-precision floating-point	
	Byte order:	Motorola (big)/Intel (little)	
No. of transmitted arbitrary frames	Up to 20		

10.2 Specifications of Input, Output, and Measurement

Arbitrary frame transmission definition	Cyclic transmission:	ON/OFF		
	Cyclic transmission interval:	10 ms, 50 ms, 200 ms, START, STOP		
	Format:	Standard / extended		
	ID:	Standard format	0x000 to 0x7FF	
		Extended format	0x00000000 to 0x1FFFFFFF	
	DLC (when ISO15765-2 is turned off):	CAN	0 to 8 bytes	
		CAN FD (The baud rate options are common to the following two CAN FD protocols: ISO-compliant and ISO-non-compliant.)	0 to 8 bytes 12, 16, 20, 24, 32, 48, 64 bytes	
	Data length (when ISO15765-2 is turned on):	0 to 41 bytes		
Transmitted data:	Entered in hexadecimal			
Diagnostic measurement setup settings				
Number of applicable channels	Up to 6			
Common settings	Measurement type	OBD II / OBD on UDS		
	Measurement interval	50 ms / 200 ms		
Channel-specific settings				

CAN ID settings	PW4001 to ECU	Format	Standard / extended	
		ID	Standard format	0x000 to 0x7FF ECU to PW4001 with automatic setting ON 0x000 to 0x7F7
			Extended format	0x00000000 to 0x1FFFFFFF
	Automatic setting, ECU to PW4001	ON / OFF		
	ECU to PW4001	Format	Standard / extended	
ID		Standard format	0x000 to 0x7FF	
		Extended format	0x00000000 to 0x1FFFFFFF	
Measurement item settings	Preset	Some items defined in SAE J1979/J1979-2 are cited.		
	PID ^{*1}	0x00 to 0xFF		
	DID ^{*2}	0x0000 to 0xFFFF		
	Name			
	Unit			
	Byte order	Motorola (big) / Intel (little)		
	Data type	Unsigned integer/signed integer/single-precision floating-point/double-precision floating-point		
	No. of response bytes ^{*1, *2}	1 to 64 bytes		
	Position of start of used bytes ^{*1, *2}	0 to 63 bytes		
	Position of end of used bytes ^{*1, *2}	0 to 63 bytes		
	Factor / offset			

*1 Settable when the measurement type is set to OBD II.

*2 Settable when the measurement type is set to OBD on UDS.

Output parameters

Selected output parameter	Notation	Selected output parameter	Notation
Voltage RMS value	Urms	Reactive power	Q
Voltage mean value rectification RMS equivalent	Umn	Fundamental wave reactive power	Qfnd
Voltage AC component	Uac	Power factor	λ
Voltage simple average	Udc	Fundamental wave power factor	λ_{fnd}
Voltage fundamental wave component	Ufnd	Voltage phase angle	θ_U
Voltage waveform peak (+)	Upk+	Current phase angle	θ_I
Voltage waveform peak (-)	Upk-	Power phase angle	\varnothing
Total voltage harmonic distortion	Uthd	Voltage frequency	fU
Voltage ripple factor	Urf	Current frequency	fI
Voltage unbalance rate	Uunb	Integrated positive current value	Ih+
Current RMS value	Irms	Integrated negative current value	Ih-
RMS equivalent of average rectified current value	Imn	Sum of positive and negative current values	Ih
Current AC component	Iac	Integrated positive power value	WP+
Current simple average	Idc	Integrated negative power value	WP-
Current fundamental wave component	Ifnd	Sum of integrated positive and negative power values	WP
Current waveform peak (+)	Ipk+	Efficiency	η
Current waveform peak (-)	Ipk-	Loss value	Loss
Total harmonic current distortion	Ithd	Torque	Tq
Current ripple factor	Irf	RPM	Spd
Current unbalance rate	Iunb	Motor power	Pm
Active power	P	Slip	Slip
Fundamental wave active power	Pfnd	Output count	Count
Apparent power	S	Output time	Time
Fundamental wave apparent power	Sfnd	User-defined formula	UDF
		CAN input value	CAN

10.3 Function Specifications

Auto-ranging

Function	The voltage and current ranges for each wiring configuration are automatically switched in response to the input. (excluding motor input ranges)
Operating mode	Off/on (selectable for each wiring configuration)
Operation	Measured values for the corresponding wiring configuration or motor input when the range changes become invalid. However, data for other wiring configurations is not affected. The waveform's period may become longer than the invalidation period if the synchronization frequency is low. In this case, measured values will take longer to stabilize than the invalid data display period. This affects not only auto-range switching, but also manual range switching.
Switching ranges Conditions	<p>Switch to the range immediately above</p> <p>When either of the following conditions is satisfied in any one of the channels in the connection:</p> <ul style="list-style-type: none"> • The RMS value is greater than or equal to 110% of the range. • The absolute value of the peak value is greater than or equal to 300% of the range. <p>Switch to the range immediately below</p> <p>When all channels in a connection satisfy both the following conditions:</p> <ul style="list-style-type: none"> • The RMS value is less than or equal to 40% of the range. • The absolute value of the peak value is less than or equal to 280% of the range immediately below. <p>The following values are used to determine which range to use:</p> <ul style="list-style-type: none"> • RMS value: Instantaneous value (not averaged). When Δ-Y conversion is set to on, multiply the voltage range by $1/\sqrt{3}$. • Peak value: Value before passing through the digital LPF and used for internal calculation

Time control

Function	Other functions are controlled based on the time. Timer control, real time control
Operation	Timer control: Stops once the set amount of time has elapsed. Real time control: Starts at the specified time and stops at the specified time.
Timer control	Off, 1 s to 9999 h 59 min. 59 s (in 1 s increments)
Real time control	Off, start time, stop time (in 1 s increments)

Hold function

(1) Hold

Function	Stops updating display of all measured values, freezing the presently on-screen figures. However, updating continues for waveforms, the clock, and on-screen peak-over conditions. Internal calculations, for example integration and averaging, continue. Cannot be used in combination with the peak hold function.
Operating mode	Off/On
Operation	Pressing the HOLD key can activate the function, lighting up the HOLD key and displaying the hold icon on the screen. Pressing the HOLD key again can turn the function off. Pressing the PEAK HOLD key can update data when the hold function has been enabled. Data is updated at the internal data intervals (which is distinct from the display update interval).
Output data	Internally retained frozen data is outputted as analog output and stored on a USB flash drive. (However, waveform output continues).
Backup	None (The function is disabled when the instrument is turned off.)
Constraint	While the hold function is activated, settings that affect measured values cannot be changed.

(2) Peak hold

Function	The display is updated by replacing all measured values with the maximum values obtained by comparing the absolute values for each measured value. However, the waveform display and integrated values continue to be updated by being replaced with instantaneous data. During average operation, the maximum value affects values measured after averaging. Cannot be used in combination with the hold function.
Operating mode	Off/On
Operation	Pressing the PEAK HOLD key can activate the function, lighting up the PEAK HOLD key and displaying the peak hold icon on the screen. Pressing the PEAK HOLD key again can turn the function off. When the peak hold function is enabled, data is updated when the HOLD key is pressed.
Output data	During the peak-hold operation, internally retained peak-hold data is outputted as analog output and stored on a USB flash drive. (However, waveform output continues).
Backup	None (The function is disabled when the instrument is turned off.)
Constraint	While the peak-hold function is activated, settings that affect measured values cannot be changed.

Calculation function

(1) Rectification method

Function	The voltage and current values used to calculate apparent and reactive power and power factor can be selected.
Operating mode	RMS, mean (Can be selected for each wiring configuration's voltage and current.)

(2) Scaling

Function	The VT ratio and CT ratio can be set so that they can affect measured values.
VT (PT) ratio	Can be set for each wiring configuration. 0.00001 to 9999.99 (The settings cannot be configured such that $(VT \times CT)$ is greater than $1.0E+06$.)
CT ratio	Can be set for each channel. 0.00001 to 9999.99 (The settings cannot be configured such that $(VT \times CT)$ is greater than $1.0E+06$.)
Display	While scaling is enabled, the [VT] and [CT] icons are displayed on the screen.

(3) Average (AVG)

Function	<p>All instantaneous measured values, including harmonics, are averaged. (Excluding peak values, integrated values, and harmonic data during the 10 ms interval data update.) Voltage (U), current (I), and power (P) values are averaged. Calculated values are computed from those values. For harmonics, instantaneous values are averaged for RMS values and content percentages. The phase angles are calculated from the average results of FFT-processed real and imaginary parts. The phase difference, distortion, and unbalance rate are calculated from data obtained by the above averaging. The ripple factor is calculated from data computed by averaging the difference between the positive and negative peak values. Measured motor-analysis values are calculated from data computed by averaging the Ch. A to Ch. D values. When the data update interval is set to 1 ms, no measurements are averaged (averaging is forcibly set to off). Moving average is not selectable in IEC measurement mode. Averaging for all flicker measurement items is not performed.</p>	
Operating mode	Off, exponential average, moving average	
Operation	Exponential average:	Data is exponentially averaged using a time constant specified by the data update intervals and the exponential average response speed. During average operation, averaged data affects all analog output and save data.
	Moving average:	Averaging is performed for the moving averaging count at the data update interval to update the output data. Same as the data update interval without averaging

10.3 Function Specifications

Exponential average response speed	Averaging count	FAST	MID	SLOW
	10 ms	0.1 s	0.8 s	5 s
	50 ms	0.5 s	4 s	25 s
	200 ms	2.0 s	16 s	100 s

These values indicate the time required for the final stabilized value to converge on the range of $\pm 1\%$ when the input changes from 0% to 90% of the range.
 Although harmonic data is not averaged when the data update interval is set at 10 ms, harmonic data contained in basic measurement items is averaged using the exponential average coefficient every 10 ms.
 The speed is fixed in IEC measurement mode.

Moving average count	2, 4, 8, 16, 32, 64 times
----------------------	---------------------------

(4) Efficiency-loss calculations

Function	The efficiency η (%) and loss (W) of each channel are calculated between wiring configurations' active power values.	
Calculation items	Active power value (P), fundamental wave active power (P _{fnd}), motor power (P _m), and user-defined formula (UDF) of each channel and wiring configuration	
Calculation precision	Performs 32-bit floating-point arithmetic operation for measured values of the parameters substituted into equations. When performing calculations between wiring configurations with different power range settings, the largest range in the same calculation is used.	
Calculation interval	Calculations are updated at the data update intervals. When performing calculations between wiring configurations with different synchronization sources, the most recent data at the time of the calculation is used.	
Number of calculations that can be performed	Four for each efficiency and loss	
Mode	Fixed mode:	In the case of items set on the input and output sides, the position in the equation is fixed, regardless of the measured value.
	Auto mode:	In the case of items set on the input and output sides, the position in the equation changes according to the positive and negative of the measured value.
Equation	Fixed mode:	Calculation items can be substituted for Pin(n) and Pout(n). Pin = Pin1 + Pin2 + Pin3 + Pin4 + Pin5 + Pin6 Pout = Pout1 + Pout2 + Pout3 + Pout4 + Pout5 + Pout6
		$\eta = 100 \times \frac{ P_{out} }{ P_{in} }$, Loss = Pin - Pout
	Auto mode:	Pin = (Sum of the absolute values of the positive parameter of the input and that of the negative parameter of the output) Pout = (Sum of the absolute values of the positive parameter of the output and that of the negative parameter of the input)
		$\eta = 100 \times \frac{ P_{out} }{ P_{in} }$, Loss = Pin - Pout

(5) User-defined formula (UDF)

Function	Calculates specified equations into which set basic measurement items (except the flicker measurement items) are substituted. No calculation can be performed if the data update interval is set to 1 ms. ([-----] is displayed.)
Calculation items	Basic measurement items (except the flicker measurement items) or 16 terms of constants with up to 6 digits, where the operators are the four fundamental operations $UDFn = ITEM1 \square ITEM2 \square ITEM3 \square ITEM4 \square \dots \square ITEM16$ ITEMn: Basic measurement items (including UDFn, excluding the flicker measurement items) or constants of up to six digits The \square characters indicate one of the following operators: plus sign (+), minus sign (-), multiplication sign (*), and division sign (/). ITEMn functions: Neg (negative sign), sin, cos, tan, abs, log10 (common logarithm), log (logarithm), exp, sqrt, asin, acos, atan, sqr Equations UDFns are calculated in the order of letters n; if a letter n on the right-hand side of an equation is more than that on the left-hand side, the previously calculated value is substituted.
Number of calculations that can be performed	20 (UDF1 to UDF20)
Maximum value setting	Set Fixed or Auto for each UDFn. Fixed: Can be set within the range of 1.000 n to 999.999 T. Auto: The first 6 digits are always displayed. (effective display range: 0 to ± 999.999 Y) The maximum value operates as a range of the UDFn.
UDF name	Up to 8 ASCII characters per UDFn
Unit	Up to 8 ASCII characters per UDFn
Integration	OFF/Positive/Negative/Total Can be set for each UDFn Off: Displays the calculated value of the UDFn. Positive: Displays the integrated value of the polarity (+) of the UDFn calculation value in UDFn. Negative: Displays the integrated value of the polarity (-) of the UDFn calculation value in UDFn. Total: Displays the integrated value of the UDFn equation in UDFn. (effective display range: 0 to ± 999.999 Y) Other values are not added if the integrated value exceeds the effective display range.

(6) Delta conversion

Function	Δ -Y:	In 3P3W3M or 3V3A wiring mode, the line voltage waveforms are converted into phase voltage waveforms using a virtual neutral point.
	Y- Δ :	In 3P4W wiring mode, the phase voltage waveforms are converted into line voltage waveforms. All voltage parameters with harmonics components, including voltage RMS values, are calculated using the converted voltages.
However, the peak-over judgment uses not-converted values. During Y- Δ conversion, if the converted value exceeds the peak threshold, it is determined as being peak-over.		
Equation	Δ -Y 3P3W3M:	$U(i)s = (u(i)s - u(i+2)s) / 3$, $U(i+1)s = (u(i+1)s - u(i)s) / 3$, $U(i+2)s = (u(i+2)s - u(i+1)s) / 3$
	Δ -Y 3V3A:	$U(i)s = (u(i)s - u(i+2)s) / 3$, $U(i+1)s = (u(i+2)s + u(i+1)s) / 3$, $U(i+2)s = (-u(i+1)s - u(i)s) / 3$
	Y- Δ :	$u(i)s = U(i)s - U(i+1)s$, $u(i+1)s = U(i+1)s - U(i+2)s$, $u(i+2)s = U(i+2)s - U(i)s$
	(i): measurement channel, u(x)s: sampled line-voltage value, U(x)s: sampled phase-voltage value	

(7) Power calculation method selection

Function	Equations for reactive power, power factor, and power phase angle can be selected. See "10.5 Specifications of Equations" (p.375)	
Equation	Type 1, Type 2, Type 3	
	Type 1:	Compatible with the Type 1 for each of the PW3390, 3193 and 3390.
	Type 2:	Compatible with the Type 2 for each of the 3192 and 3193.
	Type 3:	The active power's sign can be used as the power factor's sign.
	(Type 1, Type 2, and Type 3 are compatible with each equation of the PW6001.)	

(8) Current sensor phase compensation

Function	Current sensor harmonic phase characteristics can be compensated using calculations.	
Operating mode	Off, on, automatic (set for each channel) Automatic mode can be selected when a current sensor with the automatic recognition function is connected.	
Compensation value settings	Compensation points can be set using frequencies and phase differences.	
	Frequency:	0.1 kHz to 5000.0 kHz (in 0.1 kHz increments)
	Phase difference:	0.000° to ±180.000° (in 0.001° increments)
	The compensation value is automatically set when the current sensor is connected in the automatic operation mode.	
Maximum compensation range	Approx. 60 μ s	

(9) Voltage probe phase compensation

Function	Voltage probes harmonic phase characteristics can be compensated using calculations.	
Operating mode	Off/on (can be set for each channel)	
Compensation value settings	Compensation points can be set using frequencies and phase differences.	
	Frequency:	0.1 kHz to 5000.0 kHz (in 0.1 kHz increments)
	Phase difference:	0.000° to ±180.000° (in 0.001° increments)
Maximum compensation range	Approx. 60 μs	

Display function

(1) Wiring configuration confirmation screen

Function	Wiring diagrams as well as vector diagrams of voltage and current (for wiring configurations other than the single-phase wiring configuration only) can be displayed based on the selected measured line patterns. The on-screen vector diagram shows the vector ranges for correct connections, enabling the operator to check for proper connections.
Startup mode	The setting can be made so that the instrument always show the wiring configuration confirmation screen at startup (startup screen setting).
Simple settings	Settings can be switched over those appropriate for objects under measurement selected for each wiring configuration. [50/60Hz], [DC/WLTP], [PWM], [HIGH FREQ], [GENERAL]

(2) Vector diagram screen

Function	The screen can display wiring-specific vector graphs along with associated level values and phase angles. The display orders and vector magnification can be selected.	
Display pattern	1-vector-diagram:	Vectors can be drawn for up to four channels.
	2-vector-diagram, 4-vector-diagram:	Vectors can be drawn for each selected wiring configuration.

(3) Numerical display screen

Function	The screen can display measured power values and motor values for up to four installed channels.	
Display pattern	Basic display for each wiring configuration:	The screen can display measured values of the lines under measurement and motors connected to the instrument. In addition to the four patterns, U, I, P, and Integ as well as motor is available. On-screen values are linked to the channel indicators.
	Selective display:	The screen can display values of any measurement items selected from all basic measurement items at any positions. There are 8-, 16-, 36-, and 64-display patterns available.

(4) Harmonic display screen

Function	The screen can display measured harmonic values.	
Display pattern	Bar-graph display:	The screen can display measured harmonic items for user-specified channels as bar graphs. (up to 500th)
	List display:	The screen can display numerical values for user-specified parameters of user-specified channels.

(5) Waveform display screen

Function	The screen can display the motor waveform as well as the voltage and current waveforms.
----------	---

Display pattern	All-waveform display Waveform + numerical value display Zoom display Cursor measurement supported
-----------------	--

(6) Warning indicator

Function	Displays a warning indicator to prevent excessive input.
Overload	Lights up in yellow when the following conditions are met RMS value is greater than 150% of the range. 100% of range only in 1500 V range
Peak-over	Lights up in red when the following conditions are met Peak value is greater than 300% of the range. Peak values are those before passing through the digital LPF and are used for internal calculation.

Trend graph function

Function	Displays a graph of measured values selected as output parameters in a time series. The waveform is plotted by compressing the data at the data update interval using peak-to-peak compression based on the time axis setting, and without the data being stored.
Operation	Use the START/STOP key to start or stop plotting. Display values are plotted during hold or peak hold. Plotted data can be cleared by pressing the DATA RESET key after stopping using the STOP key, or by changing the time axis setting.
Plotted items	Up to 8 items
Time axis	50 ms/div to 24 h/div, plotting area: 20 div
Vertical axis	Auto scale (adjusts to fit data within the time axis display range within the screen), Manual (maximum and minimum display values are set by the user)

Automatic data-saving function

Function	The user-specified measured values can be saved periodically. Auto-save operation is controlled by the time control function. Data is recorded in the same file until the DATA RESET key is pressed.
Auto-save control	Off/on
Priority save destination	USB flash drive, internal memory (capacity approx.: 15 GB) Select the media to be used for saving when auto-save control is on. If there is no USB flash drive, saving will take place on the internal memory. A folder created on a USB flash drive or in the internal memory can be specified as the destination to save data.
Parameters to be saved	Selectable from all measured values, including measured harmonic values. Harmonic readings are not saved automatically when the interval is set to 1 ms.
Maximum number of parameters to be saved	Variable with the interval setting.
Interval	OFF, 1 ms, 10 ms, 50 ms, 100 ms, 200 ms, 500 ms, 1 s, 5 s, 10 s, 15 s, 30 s, 1 min, 5 min, 10 min, 15 min, 30 min, 60 min However, the interval cannot be set to less than the data update interval. The output interval of 500 ms is unavailable with the data update interval of 200 ms. <ul style="list-style-type: none"> In IEC measurement mode, the output intervals of 100 ms and 500 ms are available with the data update interval of 200 ms.
Maximum data size to be saved	Approx. 500 MB per file (automatically segmented) × 1000 files No function is provided for automatically erasing files when the media is full.
Data format	Delimiters can be selected. CSV: Measured data is delimited with commas (,) and periods (.) represent decimal points. SSV: Measured data is delimited with semicolons (;) and commas (,) represent decimal points. BIN: Common file-format that can be loaded by GENNECT One
Filename	Automatically generated based on the time and date at which measurement started.

Manual data-saving function

(1) Measured data

Function	Pressing the SAVE key can save values measured at the moment. The data is outputted to the same file until the setting is changed, or the DATA RESET key is pressed.
Save destination	USB flash drive, internal memory
Parameters to be saved	Selectable from all measured values, including measured harmonic values.
Maximum data size to be saved	500 MB per file (automatically segmented)
Data format	CSV, SSV
Filename	Automatically generated

(2) Waveform data

Function	When the Save button is tapped on the waveform screen of the touchscreen, the waveform is saved in the specified format.
Save destination	USB flash drive, internal memory
Parameters to be saved	Waveform data on the waveform screen
Maximum number of parameters to be saved	Same as the number of on-screen items
Maximum data size to be saved	Approx. 400 MB (in binary format) Approx. 2 GB (in text format) 500 MB per file (automatically segmented)
Data format	CSV, SSV, BIN, MAT
Filename	Automatically generated

(3) Screenshot

Function	Pressing the SCREEN SHOT key can save the screen displayed at the moment in PNG format. Setting list screenshot function Comment entering function Free drawing function (Concurrent use of the comment entering function and free drawing function is not available.)
Save destination	USB flash drive, internal memory, FTP server
Parameters to be saved	Screenshot data
Data format	PNG
Filename	Automatically generated

(4) Settings data

Function	Saves various settings information as settings files using the [FILE] screen. In addition, loading a settings file saved using the [FILE] screen can restore settings. However, the language and communications settings are not restored. Settings data can be opened with the image viewer because it is inserted into an image that displays a settings list.
Save destination	USB flash drive, internal memory, FTP server
Parameters to be saved	Settings data
Data format	SET
Filename	Filenames set at the time of saving (up to 8 characters)

(5) CAN output settings data

Function	Data-output settings can be saved as DBC-files using the [CAN] screen.
Save destination	USB flash drive, internal memory, FTP server
Parameters to be saved	Output settings data
Data format	DBC
Filename	Filenames set at the time of saving (up to 8 characters)

(6) User-defined formula data

Function	User-defined formulas can be saved as JSON files using the [UDF] screen. Loading a JSON file saved using the [UDF] or [FILE] screen can restore the equations. Calculation is not possible if the loaded equations include calculation items that are invalid (items that cannot be selected according to the module, option configuration, or other setting). ([-----] is displayed)
Save destination	USB flash drive, internal memory, FTP server
Parameters to be saved	User-defined formula
Data format	JSON
Filename	Filenames set at the time of saving (up to 8 characters)

Other functions

Clock function	Auto-calendar, automatic leap-year detection, 24-hour clock	
Real time accuracy	When the instrument is turned on:	± 100 ppm
	When the instrument is turned off:	Within ± 3 s/day (at 25°C [77°F])

Sensor identification	<p>Current sensors connected to input modules can be identified automatically.</p> <p>The instrument can detect sensor ranges and the connection/disconnection of sensors, displaying warning dialog boxes.</p> <p>Data compensation values provided by current sensors affect phase compensation data.</p>
Zero suppress function	<p>Selectable between OFF and ON.</p> <p>When enabled, the setting is 0.01 to 1.00% of full scale.</p> <p>When this function is enabled, values of measurement items less than the set value are replaced with zero.</p> <p>Target measurement items are listed in “10.4 Detailed Specifications of Measurement Parameters” (p.358).</p>

10.4 Detailed Specifications of Measurement Parameters

Basic measurement items

(1) Power measurement items

Measurement items		Notation	1P2W	1P3W/3P3W2M	3P3W3M/3V3A	3P4W
Voltage	RMS value	Urms	i	i, i+1, (i, i+1)	i, i+1, i+2, (i, i+1, i+2)	i, i+1, i+2, (i, i+1, i+2)
	RMS equivalent of average rectified value	Umn	i	i, i+1, (i, i+1)	i, i+1, i+2, (i, i+1, i+2)	i, i+1, i+2, (i, i+1, i+2)
	AC component	Uac	i	i, i+1	i, i+1, i+2	i, i+1, i+2
	Simple average	Udc	i	i, i+1	i, i+1, i+2	i, i+1, i+2
	Fundamental wave component	Ufnd	i	i, i+1	i, i+1, i+2	i, i+1, i+2
	Waveform peak +	Upk+	i	i, i+1	i, i+1, i+2	i, i+1, i+2
	Waveform peak -	Upk-	i	i, i+1	i, i+1, i+2	i, i+1, i+2
	Total harmonic distortion	Uthd	i	i, i+1	i, i+1, i+2	i, i+1, i+2
	Ripple factor	Urf	i	i, i+1	i, i+1, i+2	i, i+1, i+2
	Unbalance rate	Uunb	-	-	(i, i+1, i+2)	(i, i+1, i+2)
Current	RMS value	Irms	i	i, i+1, (i, i+1)	i, i+1, i+2, (i, i+1, i+2)	i, i+1, i+2, (i, i+1, i+2)
	RMS equivalent of average rectified value	Imn	i	i, i+1, (i, i+1)	i, i+1, i+2, (i, i+1, i+2)	i, i+1, i+2, (i, i+1, i+2)
	AC component	Iac	i	i, i+1	i, i+1, i+2	i, i+1, i+2
	Simple average	I _{dc}	i	i, i+1	i, i+1, i+2	i, i+1, i+2
	Fundamental wave component	Ifnd	i	i, i+1	i, i+1, i+2	i, i+1, i+2
	Waveform peak +	Ipk+	i	i, i+1	i, i+1, i+2	i, i+1, i+2
	Waveform peak -	Ipk-	i	i, i+1	i, i+1, i+2	i, i+1, i+2
	Total harmonic distortion	Ithd	i	i, i+1	i, i+1, i+2	i, i+1, i+2
	Ripple factor	Irf	i	i, i+1	i, i+1, i+2	i, i+1, i+2
	Unbalance rate	Iunb	-	-	(i, i+1, i+2)	(i, i+1, i+2)
Active power	P	i	i, i+1, (i, i+1)	i, i+1, i+2, (i, i+1, i+2)	i, i+1, i+2, (i, i+1, i+2)	

10.4 Detailed Specifications of Measurement Parameters

Measurement items		Notation	1P2W	1P3W/3P3W2M	3P3W3M/3V3A	3P4W
Fundamental wave active power		Pfnd	i	i, i+1, (i, i+1)	i, i+1, i+2, (i, i+1, i+2)	i, i+1, i+2, (i, i+1, i+2)
Apparent power		S	i	i, i+1, (i, i+1)	i, i+1, i+2, (i, i+1, i+2)	i, i+1, i+2, (i, i+1, i+2)
Fundamental wave apparent power		Sfnd	i	i, i+1, (i, i+1)	i, i+1, i+2, (i, i+1, i+2)	i, i+1, i+2, (i, i+1, i+2)
Reactive power		Q	i	i, i+1, (i, i+1)	i, i+1, i+2, (i, i+1, i+2)	i, i+1, i+2, (i, i+1, i+2)
Fundamental wave reactive power		Qfnd	i	i, i+1, (i, i+1)	i, i+1, i+2, (i, i+1, i+2)	i, i+1, i+2, (i, i+1, i+2)
Power factor		λ	i	i, i+1, (i, i+1)	i, i+1, i+2, (i, i+1, i+2)	i, i+1, i+2, (i, i+1, i+2)
Fundamental wave power factor		λ fnd	i	i, i+1, (i, i+1)	i, i+1, i+2, (i, i+1, i+2)	i, i+1, i+2, (i, i+1, i+2)
Phase angle	Voltage phase angle	θ_U	i	i, i+1	i, i+1, i+2	i, i+1, i+2
	Current phase angle	θ_I	i	i, i+1	i, i+1, i+2	i, i+1, i+2
	Power phase angle	\varnothing	i	i, i+1, (i, i+1)	i, i+1, i+2, (i, i+1, i+2)	i, i+1, i+2, (i, i+1, i+2)

i: Channels Ch. 1 to Ch. 4

(): Indicates SUM values.

10.4 Detailed Specifications of Measurement Parameters

Measurement items		Notation	Unit	Display range	Polarity (+/-)
Voltage	RMS value	Urms	V	Zero to 150% of the U range*1	
	RMS equivalent of average rectified value	Umn	V	Zero to 150% of the U range*1	
	AC component	Uac	V	Zero to 150% of the U range*1	
	Simple average	Udc	V	Zero to 150% of the U range*2	✓
	Fundamental wave component	Ufnd	V	Zero to 150% of the U range*1	
	Waveform peak +	Upk+	V	Zero to 300% of the U range*2	✓
	Waveform peak -	Upk-	V	Zero to 300% of the U range*2	✓
	Total harmonic distortion	Uthd	%	0.000 to 500.000	
	Ripple factor	Urf	%	0.000 to 500.000	
	Unbalance rate	Uunb	%	0.000 to 100.000	
Current	RMS value	Irms	A	Zero to 150% of the I range	
	RMS equivalent of average rectified value	Imn	A	Zero to 150% of the I range	
	AC component	iac	A	Zero to 150% of the I range	
	Simple average	Idc	A	Zero to 150% of the I range	✓
	Fundamental wave component	Ifnd	A	Zero to 150% of the I range	
	Waveform peak +	Ipk+	A	Zero to 300% of the I range	✓
	Waveform peak -	Ipk-	A	Zero to 300% of the I range	✓
	Total harmonic distortion	lthd	%	0.000 to 500.000	
	Ripple factor	Irf	%	0.000 to 500.000	
	Unbalance rate	Iunb	%	0.000 to 100.000	
Active power		P	W	Zero to 150% of the P range	✓
Fundamental wave active power		Pfnd	W	Zero to 150% of the P range	✓
Apparent power		S	VA	Zero to 150% of the P range	

Measurement items		Notation	Unit	Display range	Polarity (+/-)
Fundamental wave apparent power		Sfnd	VA	Zero to 150% of the P range	
Reactive power		Q	Var	Zero to 150% of the P range	✓
Fundamental wave reactive power		Qfnd	Var	Zero to 150% of the P range	✓
Power factor		λ	–	0.00000 to 1.00000	✓
Fundamental wave power factor		λ fnd	–	0.00000 to 1.00000	✓
Phase angle	Voltage phase angle	θ_U	°	0.000 to 180.000	✓
	Current phase angle	θ_I	°	0.000 to 180.000	✓
	Power phase angle	\varnothing	°	0.000 to 180.000	✓

*1 135% only for the 1500 V range. This range does not change even when the delta conversion function is used.

*2 135% only for the 1500 V range

Zero: Zero suppress set value (Off: 0%, On, 0.01% to 1.00%)

(2) Integration measurement items

Measurement items		Notation	1P2W	1P3W/3P3W2M	3P3W3M/3V3A	3P4W
Integration	Integrated positive current value*1	lh+	i	–	–	–
	Integrated negative current value*1	lh–	i	–	–	–
	Sum of integrated positive and negative current values	lh	i	i	i	i
	Integrated positive power value	WP+	i	(i, i+1)	(i, i+1, i+2)	(i, i+1, i+2)
	Integrated negative power value	WP–	i	(i, i+1)	(i, i+1, i+2)	(i, i+1, i+2)
	Sum of integrated positive and negative power values	WP	i	(i, i+1)	(i, i+1, i+2)	(i, i+1, i+2)

i: Channels Ch. 1 to Ch. 4

(): Indicates SUM values.

*1 Only channels with the integration mode set to DC mode

10.4 Detailed Specifications of Measurement Parameters

Measurement items		Notation	Unit	Display range	Polarity (+/-)
Integration	Integrated positive current value	Ih+	Ah	Zero to 1% of the I range or more*2	
	Integrated negative current value	Ih-	Ah	Zero to 1% of the I range or more*2	*3
	Sum of integrated positive and negative current values	Ih	Ah	Zero to 1% of the I range or more*2	✓
	Integrated positive power value	WP+	Wh	Zero to 1% of the P range or more*2	
	Integrated negative power value	WP-	Wh	Zero to 1% of the P range or more*2	*3
	Sum of integrated positive and negative power values	WP	Wh	Zero to 1% of the P range or more*2	✓

*2 Positive, negative, and positive/negative values are acquired using the same range. They are displayed in the digits in which the maximum value of them can be displayed.

*3 Indicates a parameter whose sign is always negative.

Zero: Zero suppress set value (Off: 0%, On, 0.01% to 1.00%)

(3) Frequency and calculation measurement items

Measurement items	Notation	Unit	Channel	Display range	Polarity (+/-)
Voltage frequency	fU	Hz	i	0.00000 Hz to 2.00000 MHz	
Current frequency	fl	Hz	i	0.00000 Hz to 2.00000 MHz	
Efficiency	η	%	1, 2, 3, 4	0.000 to 200.000	
Loss	Loss	W	1, 2, 3, 4	150% of the P range	✓
User-defined formula	UDF	Free*1	1, 2, 3, 4, 5, 6, 7, 8, 9, 10, 11, 12, 13, 14, 15, 16, 17, 18, 19, 20	Set value	✓

i: Channels Ch. 1 to Ch. 4

*1 Can be set by the user.

(4) Motor analysis measurement items (only when the motor analysis option is installed)

Wiring pattern	Ch. A		Ch. B		Ch. C		Ch. D	
	Input parameter	Notation	Input parameter	Notation	Input parameter	Notation	Input parameter	Notation
Individual Input	Voltage, pulse	Ch. A	Pulse	Ch. B	Voltage, pulse	Ch. C	Pulse	Ch. D

Wiring pattern	Ch. A		Ch. B		Ch. C		Ch. D	
	Input parameter	Notation	Input parameter	Notation	Input parameter	Notation	Input parameter	Notation
	Motor 1				Motor 2			
Torque Speed (Pulse)	Torque* ¹	Tq1	RPM	Spd1	Torque* ¹	Tq2	RPM	Spd2
	Motor 1							
Torque Speed Direction Origin	Torque* ¹	Tq1	RPM	Spd1	Rotation direction	–	Z phase	–
Torque Speed Direction	Torque* ¹	Tq1	RPM	Spd1	Rotation direction	–	Off	–
Torque Speed Origin	Torque* ¹	Tq1	RPM	Spd1	Off	–	Z phase	–
Torque Speed (Analog)	Torque* ¹	Tq1	Off	–	RPM	Spd1	Off	–

*1 Switchable between analog DC input and frequency input.

Units and display ranges of measurement items

	Measurement items	Setting	Unit	Display range* ¹	Polarity (+/-)
Ch. A	Torque	Analog DC	N·m	Zero to 150% of the range	✓
		Frequency		0% to 150% of the rated torque setting	✓
	Voltage	Analog DC	V, user-specified	Zero to 150% of the range	✓
	Pulse frequency	Pulse	Hz		
Ch. B	RPM	Pulse	r/min		
	Pulse frequency	Pulse	Hz		
Ch. C	Torque	Analog DC	N·m	Zero to 150% of the range	✓
		Frequency		0% to 150% of the rated torque setting	✓
	RPM	Analog DC	r/min	Zero to 150% of the range	✓
	Voltage	Analog DC	V, user-specified	Zero to 150% of the range	✓
	Pulse frequency	Pulse	Hz		
Ch. D	RPM	Pulse	r/min		
	Pulse frequency	Pulse	Hz		

10.4 Detailed Specifications of Measurement Parameters

	Measurement items	Setting	Unit	Display range*1	Polarity (+/-)
Pm	Motor power		W	Zero to 150% of the Pm range	✓
Slip	Slip		%	0.000 to 100.000	✓

*1 When scaling is set, add the scaling value to the range.

Zero: Zero suppress set value (Off: 0%, On, 0.01% to 1.00%)

(5) Flicker measurement items (only in IEC measurement mode)

Measurement items	Notation	1P2W	1P3W/3P3W2M	3P3W3M/3V3A	3P4W
Short-term flicker value	Pst	i	i	i	i
Maximum short-term flicker value	PstMax	i	i	i	i
Long-term flicker value	Plt	i	i	i	i
Maximum instantaneous flicker value	PinstMax	i	i	i	i
Minimum instantaneous flicker value	PinstMin	i	i	i	i
Relative steady-state voltage change	dc	i	i	i	i
Maximum relative voltage change	dmax	i	i	i	i
Period during which the relative voltage change exceeds the threshold	Tmax	i	i	i	i

i: Channels Ch. 1 to Ch. 4

Measurement items	Notation	Unit	Display range	Polarity (+/-)
Short-term flicker value	Pst	–	From 0.001	None
Maximum short-term flicker value	PstMax	–	From 0.001	
Long-term flicker value	Plt	–	From 0.001	
Maximum instantaneous flicker value	PinstMax	–	From 0.001	
Minimum instantaneous flicker value	PinstMin	–	From 0.001	
Relative steady-state voltage change	dc	%	0.001 to 999.999	
Maximum relative voltage change	dmax	%	0.001 to 999.999	
Period during which the relative voltage change exceeds the threshold	Tmax	s	From 0.001 m	

(6) CAN measurement items

Measurement items	Notation	Unit	Channel	Display range	Polarity (+/-)
CAN input value	CAN	Free*1	1, 2, 3, 4, 5, 6, 7, 8, 9, 10, 11, 12, 13, 14, 15, 16, 17, 18, 19, 20	Set value	✓

*1 Can be set by the user.

Harmonic measurement items

Measurement items	Notation	1P2W	1P3W/3P3W2M	3P3W3M/3V3A	3P4W
Harmonic voltage RMS value	U _k	i	i	i	i
Harmonic voltage phase angle	θU _k	i	i	i	i
Harmonic current RMS value	I _k	i	i	i	i
Harmonic current phase angle	θI _k	i	i	i	i
Harmonic active power	P _k	i	i, (i, i+1)	i, (i, i+1, i+2)	i, (i, i+1, i+2)
Harmonic voltage/current phase difference	θ _k	i	i, (i, i+1)	i, (i, i+1, i+2)	i, (i, i+1, i+2)
Harmonic voltage content percentage	H _{DUk}	i	l	l	l
Harmonic current content percentage	H _{DIk}	i	l	l	l
Harmonic power content percentage	H _{DPk}	i	i, (i, i+1)	i, (i, i+1, i+2)	i, (i, i+1, i+2)

i: Channels Ch. 1 to Ch. 4

Measurement items	Notation	Unit	Display range	Polarity (+/-)
Harmonic voltage RMS value	U _k	V	0% to 150% of the U range	*
Harmonic voltage phase angle	θU _k	°	0.000 to 180.000	✓
Harmonic current RMS value	I _k	A	0% to 150% of the I range	*
Harmonic current phase angle	θI _k	°	0.000 to 180.000	✓
Harmonic active power	P _k	W	0% to 150% of the P range	✓
Harmonic voltage/current phase difference	θ _k	°	0.000 to 180.000	✓
Harmonic voltage content percentage	H _{DUk}	%	0.000 to 100.000	*
Harmonic current content percentage	H _{DIk}	%	0.000 to 100.000	*
Harmonic power content percentage	H _{DPk}	%	0.000 to 100.000	✓

*: Indicates an item in which only the 0th component is marked with a polarity sign (+/-).

Inter-harmonic measurement items (only in IEC measurement mode)

Measurement items	Notation	1P2W	1P3W/3P3W2M	3P3W3M/3V3A	3P4W
Inter-harmonic voltage RMS value	iU _k	i	i	i	i

10.4 Detailed Specifications of Measurement Parameters

Measurement items	Notation	1P2W	1P3W/3P3W2M	3P3W3M/3V3A	3P4W
Inter-harmonic voltage content percentage	iHDUk	i	i	i	i
Inter-harmonic current RMS value	ilk	i	i	i	i
Inter-harmonic current content percentage	iHDIk	i	i	i	i

i: Channels Ch. 1 to Ch. 4

Measurement items	Notation	Unit	Display range	Polarity (+/-)
Inter-harmonic voltage RMS value	iUk	V	0% to 150% of the U range	None
Inter-harmonic voltage content percentage	iHDUk	%	0.000 to 100.000	
Inter-harmonic current RMS value	ilk	A	0% to 150% of the I range	
Inter-harmonic current content percentage	iHDIk	%	0.000 to 100.000	

Power range configuration

(1) With a 20 A sensor

Voltage, wiring configuration, current		400.000 mA	800.000 mA	2.00000 A	4.00000 A	8.00000 A	20.0000 A
6.00000 V	1P2W	2.40000	4.80000	12.0000	24.0000	48.0000	120.000
	1P3W, 3V3A 3P3W (2M, 3M)	4.80000	9.60000	24.0000	48.0000	96.0000	240.000
	3P4W	7.20000	14.4000	36.0000	72.0000	144.000	360.000
15.0000 V	1P2W	6.00000	12.0000	30.0000	60.0000	120.000	300.000
	1P3W, 3V3A 3P3W (2M, 3M)	12.0000	24.0000	60.0000	120.000	240.000	600.000
	3P4W	18.0000	36.0000	90.0000	180.000	360.000	900.000
30.0000 V	1P2W	12.0000	24.0000	60.0000	120.000	240.000	600.000
	1P3W, 3V3A 3P3W (2M, 3M)	24.0000	48.0000	120.000	240.000	480.000	1.20000 k
	3P4W	36.0000	72.0000	180.000	360.000	720.000	1.80000 k
60.0000 V	1P2W	24.0000	48.0000	120.000	240.000	480.000	1.20000 k
	1P3W, 3V3A 3P3W (2M, 3M)	48.0000	96.0000	240.000	480.000	960.000	2.40000 k
	3P4W	72.0000	144.000	360.000	720.000	1.44000 k	3.60000 k
150.000 V	1P2W	60.0000	120.000	300.000	600.000	1.20000 k	3.00000 k
	1P3W, 3V3A 3P3W (2M, 3M)	120.000	240.000	600.000	1.20000 k	2.40000 k	6.00000 k
	3P4W	180.000	360.000	900.000	1.80000 k	3.60000 k	9.00000 k
300.000 V	1P2W	120.000	240.000	600.000	1.20000 k	2.40000 k	6.00000 k
	1P3W, 3V3A 3P3W (2M, 3M)	240.000	480.000	1.20000 k	2.40000 k	4.80000 k	12.0000 k
	3P4W	360.000	720.000	1.80000 k	3.60000 k	7.20000 k	18.0000 k
600.000 V	1P2W	240.000	480.000	1.20000 k	2.40000 k	4.80000 k	12.0000 k
	1P3W, 3V3A 3P3W (2M, 3M)	480.000	960.000	2.40000 k	4.80000 k	9.60000 k	24.0000 k
	3P4W	720.000	1.44000 k	3.60000 k	7.20000 k	14.4000 k	36.0000 k
1.50000 kV	1P2W	600.000	1.20000 k	3.00000 k	6.00000 k	12.0000 k	30.0000 k
	1P3W, 3V3A 3P3W (2M, 3M)	1.20000 k	2.40000 k	6.00000 k	12.0000 k	24.0000 k	60.0000 k
	3P4W	1.80000 k	3.60000 k	9.00000 k	18.0000 k	36.0000 k	90.0000 k

The following units of measurement are used: watt (W) for active power (P), volt-ampere (VA) for apparent power (S), and volt-ampere reactive (var) for reactive power (Q).

Multiply the figures given in this table by 1/10 if using a 2 A sensor, by 10 if using a 200 A sensor, or by 100 if using a 2 kA sensor.

(2) With a 50 A sensor

Voltage, wiring configuration, current		1.00000 A	2.00000 A	5.00000 A	10.0000 A	20.0000 A	50.0000 A
6.00000 V	1P2W	6.00000	12.0000	30.0000	60.0000	120.000	300.000
	1P3W, 3V3A 3P3W (2M, 3M)	12.0000	24.0000	60.0000	120.000	240.000	600.000
	3P4W	18.0000	36.0000	90.0000	180.000	360.000	900.000
15.0000 V	1P2W	15.0000	30.0000	75.0000	150.000	300.000	750.000
	1P3W, 3V3A 3P3W (2M, 3M)	30.0000	60.0000	150.000	300.000	600.000	1.50000 k
	3P4W	45.0000	90.0000	225.000	450.000	900.000	2.25000 k
30.0000 V	1P2W	30.0000	60.0000	150.000	300.000	600.000	1.50000 k
	1P3W, 3V3A 3P3W (2M, 3M)	60.0000	120.000	300.000	600.000	1.20000 k	3.00000 k
	3P4W	90.0000	180.000	450.000	900.000	1.80000 k	4.50000 k
60.0000 V	1P2W	60.0000	120.000	300.000	600.000	1.20000 k	3.00000 k
	1P3W, 3V3A 3P3W (2M, 3M)	120.000	240.000	600.000	1.20000 k	2.40000 k	6.00000 k
	3P4W	180.000	360.000	900.000	1.80000 k	3.60000 k	9.00000 k
150.000 V	1P2W	150.000	300.000	750.000	1.50000 k	3.00000 k	7.50000 k
	1P3W, 3V3A 3P3W (2M, 3M)	300.000	600.000	1.50000 k	3.00000 k	6.00000 k	15.0000 k
	3P4W	450.000	900.000	2.25000 k	4.50000 k	9.00000 k	22.5000 k
300.000 V	1P2W	300.000	600.000	1.50000 k	3.00000 k	6.00000 k	15.0000 k
	1P3W, 3V3A 3P3W (2M, 3M)	600.000	1.20000 k	3.00000 k	6.00000 k	12.0000 k	30.0000 k
	3P4W	900.000	1.80000 k	4.50000 k	9.00000 k	18.0000 k	45.0000 k
600.000 V	1P2W	600.000	1.20000 k	3.00000 k	6.00000 k	12.0000 k	30.0000 k
	1P3W, 3V3A 3P3W (2M, 3M)	1.20000 k	2.40000 k	6.00000 k	12.0000 k	24.0000 k	60.0000 k
	3P4W	1.80000 k	3.60000 k	9.00000 k	18.0000 k	36.0000 k	90.0000 k
1.50000 kV	1P2W	1.50000 k	3.00000 k	7.50000 k	15.0000 k	30.0000 k	75.0000 k
	1P3W, 3V3A 3P3W (2M, 3M)	3.00000 k	6.00000 k	15.0000 k	30.0000 k	60.0000 k	150.000 k
	3P4W	4.50000 k	9.00000 k	22.5000 k	45.0000 k	90.0000 k	225.000 k

The following units of measurement are used: watt (W) for active power (P), volt-ampere (VA) for apparent power (S), and volt-ampere reactive (var) for reactive power (Q).

10.4 Detailed Specifications of Measurement Parameters

Multiply the figures given in this table by 1/10 if using a 5 A sensor, by 10 if using a 500 A sensor, or by 100 if using a 5 kA sensor.

(3) With a 1 kA sensor

Voltage, wiring configuration, current		20.0000 A	40.0000 A	100.000 A	200.000 A	400.000 A	1.00000 kA
6.00000 V	1P2W	120.000	240.000	600.000	1.20000 k	2.40000 k	6.00000 k
	1P3W, 3V3A 3P3W (2M, 3M)	240.000	480.000	1.20000 k	2.40000 k	4.80000 k	12.0000 k
	3P4W	360.000	720.000	1.80000 k	3.60000 k	7.20000 k	18.0000 k
15.0000 V	1P2W	300.000	600.000	1.50000 k	3.00000 k	6.00000 k	15.0000 k
	1P3W, 3V3A 3P3W (2M, 3M)	600.000	1.20000 k	3.00000 k	6.00000 k	12.0000 k	30.0000 k
	3P4W	900.000	1.80000 k	4.50000 k	9.00000 k	18.0000 k	45.0000 k
30.0000 V	1P2W	600.000	1.20000 k	3.00000 k	6.00000 k	12.0000 k	30.0000 k
	1P3W, 3V3A 3P3W (2M, 3M)	1.20000 k	2.40000 k	6.00000 k	12.0000 k	24.0000 k	60.0000 k
	3P4W	1.80000 k	3.60000 k	9.00000 k	18.0000 k	36.0000 k	90.0000 k
60.0000 V	1P2W	1.20000 k	2.40000 k	6.00000 k	12.0000 k	24.0000 k	60.0000 k
	1P3W, 3V3A 3P3W (2M, 3M)	2.40000 k	4.80000 k	12.0000 k	24.0000 k	48.0000 k	120.000 k
	3P4W	3.60000 k	7.20000 k	18.0000 k	36.0000 k	72.0000 k	180.000 k
150.000 V	1P2W	3.00000 k	6.00000 k	15.0000 k	30.0000 k	60.0000 k	150.000 k
	1P3W, 3V3A 3P3W (2M, 3M)	6.00000 k	12.0000 k	30.0000 k	60.0000 k	120.000 k	300.000 k
	3P4W	9.00000 k	18.0000 k	45.0000 k	90.0000 k	180.000 k	450.000 k
300.000 V	1P2W	6.00000 k	12.0000 k	30.0000 k	60.0000 k	120.000 k	300.000 k
	1P3W, 3V3A 3P3W (2M, 3M)	12.0000 k	24.0000 k	60.0000 k	120.000 k	240.000 k	600.000 k
	3P4W	18.0000 k	36.0000 k	90.0000 k	180.000 k	360.000 k	900.000 k
600.000 V	1P2W	12.0000 k	24.0000 k	60.0000 k	120.000 k	240.000 k	600.000 k
	1P3W, 3V3A 3P3W (2M, 3M)	24.0000 k	48.0000 k	120.000 k	240.000 k	480.000 k	1.20000 M
	3P4W	36.0000 k	72.0000 k	180.000 k	360.000 k	720.000 k	1.80000 M
1.50000 kV	1P2W	30.0000 k	60.0000 k	150.000 k	300.000 k	600.000 k	1.50000 M
	1P3W, 3V3A 3P3W (2M, 3M)	60.0000 k	120.000 k	300.000 k	600.000 k	1.20000 M	3.00000 M
	3P4W	90.0000 k	180.000 k	450.000 k	900.000 k	1.80000 M	4.50000 M

The following units of measurement are used: watt (W) for active power (P), volt-ampere (VA) for apparent power (S), and volt-ampere reactive (var) for reactive power (Q).

Special values

The measurement item will be replaced with a special value when the following conditions are met. If the conditions for each special value are met simultaneously, the error value will take priority.

Special values	Value	Conditions
Error value	77777.7E+99*1	When settings related to a measurement item are changed Or, when measurement is not possible immediately after startup or due to setting-imposed restrictions
Over value	99999.9E+99*1	Voltage peak-over

*1 [-----] is displayed on the screen.

Target measurement items

Targeted: ✓ , Not targeted: –

Measurement items		Measurement items	Error value	Over value	
				Screen	File/Communication
Voltage	RMS value	Urms	✓	–	✓
	RMS equivalent of average rectified value	Umn	✓	–	✓
	AC component	Uac	✓	–	✓
	Simple average	Udc	✓	–	✓
	Fundamental wave component	Ufnd	✓	–	✓
	Waveform peak +	Upk+	✓	✓	✓
	Waveform peak –	Upk–	✓	✓	✓
	Total harmonic distortion	Uthd	✓	–	✓
	Ripple factor	Urf	✓	–	✓
	Unbalance rate	Uunb	✓	–	✓
	Voltage frequency	fU	✓	–	✓

10.4 Detailed Specifications of Measurement Parameters

Measurement items		Measurement items	Error value	Over value	
				Screen	File/Communication
Current	RMS value	Irms	✓	–	✓
	RMS equivalent of average rectified value	Imn	✓	–	✓
	AC component	Iac	✓	–	✓
	Simple average	I _{dc}	✓	–	✓
	Fundamental wave component	I _{fnd}	✓	–	✓
	Waveform peak +	I _{pk+}	✓	✓	✓
	Waveform peak –	I _{pk-}	✓	✓	✓
	Total harmonic distortion	I _{thd}	✓	–	✓
	Ripple factor	I _{rf}	✓	–	✓
	Unbalance rate	I _{unb}	✓	–	✓
	Current frequency	f _i	✓	–	✓
Power	Active power	P	✓ *1	–	✓ *1
	Fundamental wave active power	P _{fnd}	✓ *1	–	✓ *1
	Apparent power	S	✓ *1	–	✓ *1
	Fundamental wave apparent power	S _{fnd}	✓ *1	–	✓ *1
	Reactive power	Q	✓ *1	–	✓ *1
	Fundamental wave reactive power	Q _{fnd}	✓ *1	–	✓ *1
	Power factor	λ	✓ *1	–	✓ *1
	Fundamental wave power factor	λ _{fnd}	✓ *1	–	✓ *1
Phase angle	Voltage phase angle	θ _U	✓	–	✓
	Current phase angle	θ _I	✓	–	✓
	Power phase angle	∅	✓ *1	–	✓ *1

Measurement items		Measurement items	Error value	Over value	
				Screen	File/Communication
Integration	Integrated positive current value	Ih+	✓	–	–
	Integrated negative current value	Ih–	✓	–	–
	Sum of integrated positive and negative current values	Ih	✓	–	–
	Integrated positive power value	WP+	✓ *1	–	–
	Integrated negative power value	WP–	✓ *1	–	–
	Sum of integrated positive and negative power values	WP	✓ *1	–	–
Motor analysis	Voltage	Ch. A, Ch. C	✓	–	–
	Pulse	Ch. B, Ch. D	✓	–	–
	Torque	Tq	✓	–	–
	RPM	Spd	✓	–	–
	Motor power	Pm	✓	–	–
	Slip	Slip	✓	–	–
Flicker	Short-term flicker value	Pst	✓	–	–
	Maximum short-term flicker value	PstMax	✓	–	–
	Long-term flicker value	Plt	✓	–	–
	Maximum instantaneous flicker value	PinstMax	✓	–	–
	Minimum instantaneous flicker value	PinstMin	✓	–	–
	Relative steady-state voltage change	dc	✓	–	–
	Maximum relative voltage change	dmax	✓	–	–
	Period during which the relative voltage change exceeds the threshold	Tmax	✓	–	–
Efficiency	η	✓ *2	–	–	
Loss	Loss	✓ *2	–	–	
User-defined formula	UDF	✓ *2	–	–	
CAN input	CAN	✓	–	–	

10.4 Detailed Specifications of Measurement Parameters

Measurement items		Measurement items	Error value	Over value	
				Screen	File/Communication
Harmonics	Harmonic voltage RMS value	U _k	✓	–	–
	Harmonic voltage phase angle	θU _k	✓	–	–
	Harmonic current RMS value	I _k	✓	–	–
	Harmonic current phase angle	θI _k	✓	–	–
	Harmonic active power	P _k	✓	–	–
	Harmonic voltage/current phase difference	θ _k	✓	–	–
	Harmonic voltage content percentage	H _{DUk}	✓	–	–
	Harmonic current content percentage	H _{DIk}	✓	–	–
	Harmonic power content percentage	H _{DPk}	✓	–	–
Intermediate harmonic	Inter-harmonic voltage RMS value	iU _k	✓	–	–
	Inter-harmonic voltage content percentage	iH _{DUk}	✓	–	–
	Inter-harmonic current RMS value	iI _k	✓	–	–
	Inter-harmonic current content percentage	iH _{DIk}	✓	–	–

*1 If either the voltage or current is a special value, it will be replaced with a special value.

*2 If even there is one channel with an error value, it will be replaced with an error value.

Measurement items that exceed the display range will be replaced with an over value.

10.5 Specifications of Equations

Equations for basic measurement items

Item	Wiring configuration					
	1P2W	1P3W	3P3W2M	3V3A	3P3W3M	3P4W
Voltage RMS value	$U_{rms(i)} = \sqrt{\frac{1}{M} \sum_{s=0}^{M-1} (U_{(i)s})^2}$	$U_{rms(i)(i+1)} = \frac{1}{2} (U_{rms(i)} + U_{rms(i+1)})$		$U_{rms(i)(i+1)(i+2)} = \frac{1}{3} (U_{rms(i)} + U_{rms(i+1)} + U_{rms(i+2)})$		
RMS equivalent of voltage average rectified value	$U_{mn(i)} = \frac{\pi}{2\sqrt{2}} \frac{1}{M} \sum_{s=0}^{M-1} U_{(i)s} $	$U_{mn(i)(i+1)} = \frac{1}{2} (U_{mn(i)} + U_{mn(i+1)})$		$U_{mn(i)(i+1)(i+2)} = \frac{1}{3} (U_{mn(i)} + U_{mn(i+1)} + U_{mn(i+2)})$		
Voltage AC component	$U_{ac(i)} = \sqrt{(U_{rms(i)})^2 - (U_{dc(i)})^2}$					
Voltage simple average	$U_{dc(i)} = \frac{1}{M} \sum_{s=0}^{M-1} U_{(i)s}$					
Voltage fundamental wave component	Harmonic voltage $U_{1(i)}$ in harmonic equation					
Voltage peak	$U_{pk+(i)} = U_{(i)s} \text{ maximum of } M \text{ data points}$ $U_{pk-(i)} = U_{(i)s} \text{ minimum of } M \text{ data points}$					
Total voltage harmonic distortion	$U_{thd(i)}$ in harmonic equation					
Voltage ripple factor	$\frac{(U_{pk+(i)} - U_{pk-(i)})}{(2 \times U_{dc(i)})} \times 100$					
Voltage phase angle	$\theta U_{1(i)}$ in harmonic equation					

10.5 Specifications of Equations

Item	Wiring configuration					
	1P2W	1P3W	3P3W2M	3V3A	3P3W3M	3P4W
Voltage unbalance rate				$U_{umb(i)(i+1)(i+2)} = \sqrt{\frac{1-\sqrt{3-6\beta}}{1+\sqrt{3-6\beta}}} \times 100$ $\beta = \frac{U_{(i)(i+1)}^4 + U_{(i+1)(i+2)}^4 + U_{(i+2)(i)}^4}{(U_{(i)(i+1)}^2 + U_{(i+1)(i+2)}^2 + U_{(i+2)(i)}^2)^2}$ <p>Example: When using Ch. 1 to Ch. 3</p> $\beta = \frac{U_{12}^4 + U_{23}^4 + U_{31}^4}{(U_{12}^2 + U_{23}^2 + U_{31}^2)^2}$ <p>U_{12}, U_{23}, and U_{31} are fundamental wave voltage RMS values (line current), which are obtained from harmonic calculation results.</p>		
(i): measurement channel, M: number of samples between sync timings, s: sample point number						

Item	Wiring configuration					
	1P2W	1P3W	3P3W2M	3V3A	3P3W3M	3P4W
Current RMS value	$I_{rms(i)} = \sqrt{\frac{1}{M} \sum_{s=0}^{M-1} (I_{(i)s})^2}$	$I_{rms(i)(i+1)} = \frac{1}{2} (I_{rms(i)} + I_{rms(i+1)})$		$I_{rms(i)(i+1)(i+2)} = \frac{1}{2} (I_{rms(i)} + I_{rms(i+1)})$		
RMS equivalent of average rectified current value	$I_{mn(i)} = \frac{\pi}{2\sqrt{2}} \frac{1}{M} \sum_{s=0}^{M-1} I_{(i)s} $	$I_{mn(i)(i+1)} = \frac{1}{2} (I_{mn(i)} + I_{mn(i+1)})$		$I_{mn(i)(i+1)(i+2)} = \frac{1}{3} (I_{mn(i)} + I_{mn(i+1)} + I_{mn(i+2)})$		
Current AC component	$I_{ac(i)} = \sqrt{(I_{rms(i)})^2 - (I_{dc(i)})^2}$					
Current simple average	$I_{dc(i)} = \frac{1}{M} \sum_{s=0}^{M-1} I_{(i)s}$					
Current fundamental wave component	Harmonic current $I_{1(i)}$ in harmonic equation					
Current peak	$I_{pk+(i)} = I_{(i)s}$ maximum of M data points $I_{pk-(i)} = I_{(i)s}$ minimum of M data points					
Total current harmonic distortion	$I_{thd(i)}$ in harmonic equation					
Current ripple factor	$\frac{(I_{pk+(i)} - I_{pk-(i)})}{(2 \times I_{dc(i)})} \times 100$					

Item	Wiring configuration					
	1P2W	1P3W	3P3W2M	3V3A	3P3W3M	3P4W
Current phase angle	$\theta_{I_{(i)}}$ in harmonic equation					
Current unbalance rate					$I_{umb_{(i)(i+1)(i+2)}} = \sqrt{\frac{1-\sqrt{3-6\beta}}{1+\sqrt{3-6\beta}}} \times 100$ $\beta = \frac{I_{(i)(i+1)}^4 + I_{(i+1)(i+2)}^4 + I_{(i+2)(i)}^4}{\left(I_{(i)(i+1)}^2 + I_{(i+1)(i+2)}^2 + I_{(i+2)(i)}^2\right)^2}$ <p>Example: When using Ch. 1 to Ch. 3</p> $\beta = \frac{I_{12}^4 + I_{23}^4 + I_{31}^4}{\left(I_{12}^2 + I_{23}^2 + I_{31}^2\right)^2}$ <p>I_{12}, I_{23}, and I_{31} are fundamental wave current RMS values (line current), which are obtained from harmonic calculation results.</p>	
(i): measurement channel, M: number of samples between sync timings, s: sample point number						

Item	Wiring configuration					
	1P2W	1P3W	3P3W2M	3V3A	3P3W3M	3P4W
Active power	$P_{(i)} = \frac{1}{M} \sum_{s=0}^{M-1} (U_{(i)s} \times I_{(i)s})$	$P_{(i)(i+1)} = P_{(i)} + P_{(i+1)}$		$P_{(i)(i+1)(i+2)} = P_{(i)} + P_{(i+1)}$	$P_{(i)(i+1)(i+2)} = P_{(i)} + P_{(i+1)} + P_{(i+2)}$	
	<ul style="list-style-type: none"> In 3P3W3M and 3P4W wiring modes, voltage waveform $U_{(i)s}$ is phase voltage. In 3P3W3M wiring mode, sampled voltage, which is line voltage, is converted into phase voltage. $U_{(i)s} = (u_{(i)s} - u_{(i+2)s})/3$, $U_{(i+1)s} = (u_{(i+1)s} - u_{(i)s})/3$, $U_{(i+2)s} = (u_{(i+2)s} - u_{(i+1)s})/3$ $u_{(i)s}$: sampled line voltage value of channel (i) $U_{(i)s}$: calculated phase voltage of channel (i) In 3P4W wiring mode, sampled voltage is phase voltage, which does not need conversion. In 3V3A mode with Δ-Y conversion set to on, the 3P3W3M or 3P4W equation is used. In 3V3A wiring mode, voltage $U_{(i)}$ is line voltage. (3P3W2M and 3V3A wiring modes performs the same calculation.) The polarity sign of active power P indicates the flowing direction of power: $+P$ indicates consumption, whereas $-P$ indicates regeneration. 					
Apparent power	$S_{(i)} = U_{(i)} \times I_{(i)}$	$S_{(i)(i+1)} = S_{(i)} + S_{(i+1)}$	$S_{(i)(i+1)} = \frac{\sqrt{3}}{2} (S_{(i)} + S_{(i+1)})$	$S_{(i)(i+1)(i+2)} = \frac{\sqrt{3}}{3} (S_{(i)} + S_{(i+1)} + S_{(i+2)})$	$S_{(i)(i+1)(i+2)} = S_{(i)} + S_{(i+1)} + S_{(i+2)}$	
	<ul style="list-style-type: none"> For $U_{(i)}$ and $I_{(i)}$ the rectification method can be selected between rms and mean. If $S_{(i)} < P_{(i)}$, then $S_{(i)} = P_{(i)}$, $Q_{(i)} = 0$, and $\Lambda_{(i)} = 1$. In 3P3W3M and 3P4W wiring modes, voltage $U_{(i)}$ is phase voltage. In 3V3A wiring mode, voltage $U_{(i)}$ is line voltage. 					

10.5 Specifications of Equations

Item	Wiring configuration					
	1P2W	1P3W	3P3W2M	3V3A	3P3W3M	3P4W
Reactive power	When equation Type 1 or Type 3 is selected					
	$Q_{(i)} = si_{(i)} \sqrt{S_{(i)}^2 - P_{(i)}^2}$	$Q_{(i)(i+1)} = Q_{(i)} + Q_{(i+1)}$		$Q_{(i)(i+1)(i+2)} = Q_{(i)} + Q_{(i+1)}$	$Q_{(i)(i+1)(i+2)} = Q_{(i)} + Q_{(i+1)} + Q_{(i+2)}$	
	When equation Type 2 is selected					
	$Q_{(i)} = \sqrt{S_{(i)}^2 - P_{(i)}^2}$	$Q_{(i)(i+1)} = \sqrt{S_{(i)(i+1)}^2 - P_{(i)(i+1)}^2}$		$Q_{(i)(i+1)(i+2)} = \sqrt{S_{(i)(i+1)(i+2)}^2 - P_{(i)(i+1)(i+2)}^2}$		
	<ul style="list-style-type: none"> When equation Type 1 or Type 3 is selected, the polarity sign si for the reactive power Q indicates the lead/lag polarity; no sign indicates lag, whereas a negative sign (-) indicates lead. The polarity sign $si_{(i)}$ is acquired based on the lead/lag between voltage waveform $U_{(i)s}$ and current waveform $I_{(i)s}$ for each measurement channel (i). In 3P3W3M and 3P4W wiring modes, voltage waveform $U_{(i)s}$ is phase voltage. In 3P3W3M wiring mode, sampled voltage, which is line voltage, is converted into phase voltage. $U_{(i)s} = (u_{(i)s} - u_{(i+2)s})/3$, $U_{(i+1)s} = (u_{(i+1)s} - u_{(i)s})/3$, $U_{(i+2)s} = (u_{(i+2)s} - u_{(i+1)s})/3$ $u_{(i)s}$: sampled line voltage value of channel (i) $U_{(i)s}$: calculated phase voltage of channel (i) In 3P4W wiring mode, sampled voltage is phase voltage, which does not need conversion. When equation Type 2 is selected, results are unsigned. 					
	When equation Type 1 is selected					
$\lambda_{(i)} = si_{(i)} \left \frac{P_{(i)}}{S_{(i)}} \right $	$\lambda_{(i)(i+1)} = si_{(i)(i+1)} \left \frac{P_{(i)(i+1)}}{S_{(i)(i+1)}} \right $		$\lambda_{(i)(i+1)(i+2)} = si_{(i)(i+1)(i+2)} \left \frac{P_{(i)(i+1)(i+2)}}{S_{(i)(i+1)(i+2)}} \right $			
When equation Type 2 is selected						
$\lambda_{(i)} = \left \frac{P_{(i)}}{S_{(i)}} \right $	$\lambda_{(i)(i+1)} = \left \frac{P_{(i)(i+1)}}{S_{(i)(i+1)}} \right $		$\lambda_{(i)(i+1)(i+2)} = \left \frac{P_{(i)(i+1)(i+2)}}{S_{(i)(i+1)(i+2)}} \right $			
When equation Type 3 is selected						
$\lambda_{(i)} = \frac{P_{(i)}}{S_{(i)}}$	$\lambda_{(i)(i+1)} = \frac{P_{(i)(i+1)}}{S_{(i)(i+1)}}$		$\lambda_{(i)(i+1)(i+2)} = \frac{P_{(i)(i+1)(i+2)}}{S_{(i)(i+1)(i+2)}}$			
<ul style="list-style-type: none"> When equation Type 1 is selected, the polarity sign si for power factor λ indicates the lead/lag polarity; no sign indicates lag, whereas negative sign (-) indicates lead. The polarity sign $si_{(i)}$ is acquired based on the lead/lag between voltage waveform $U_{(i)s}$ and current waveform $I_{(i)s}$ for each measurement channel (i). The signs of si_{12}, si_{34}, and si_{123} are acquired from those of Q_{12}, Q_{34}, and Q_{123}, respectively. When equation Type 3 is selected, the sign of active power P is used without being reversed for a polarity sign. 						

Item	Wiring configuration					
	1P2W	1P3W	3P3W2M	3V3A	3P3W3M	3P4W
Power phase angle	When equation Type 1 is selected					
	$\phi_{(i)} = si_{(i)} \cos^{-1} \lambda_{(i)} $	$\phi_{(i)(i+1)} = si_{(i)(i+1)} \cos^{-1} \lambda_{(i)(i+1)} $			$\phi_{(i)(i+1)(i+2)} = si_{(i)(i+1)(i+2)} \cos^{-1} \lambda_{(i)(i+1)(i+2)} $	
	When equation Type 2 is selected					
	$\phi_{(i)} = \cos^{-1} \lambda_{(i)} $	$\phi_{(i)(i+1)} = \cos^{-1} \lambda_{(i)(i+1)} $			$\phi_{(i)(i+1)(i+2)} = \cos^{-1} \lambda_{(i)(i+1)(i+2)} $	
	When equation Type 3 is selected					
	$\phi_{(i)} = \cos^{-1} \lambda_{(i)}$	$\phi_{(i)(i+1)} = \cos^{-1} \lambda_{(i)(i+1)}$			$\phi_{(i)(i+1)(i+2)} = \cos^{-1} \lambda_{(i)(i+1)(i+2)}$	
	<ul style="list-style-type: none"> When equation Type 1 is selected, polarity sign si indicates the lead/lag polarity; no sign indicates lag, whereas negative sign (-) indicates lead. The polarity sign $si_{(ij)}$ is acquired based on the lead/lag between voltage waveform $U_{(ij)s}$ and current waveform $I_{(ij)s}$ for each measurement channel (i). The signs of si_{12}, si_{34}, and si_{123} are acquired from those of Q_{12}, Q_{34}, and Q_{123}, respectively. In equation Type 1 and Type 2, the expression $\cos^{-1} \lambda$ is used when the inequality $P \geq 0$ is true; the expression $180 - \cos^{-1} \lambda$ is used instead when $P < 0$. 					
<p>(i): measurement channel, M: number of samples between sync timings, s: sample point number The 3P4W equations are used for Y-Δ conversion in 3V3A and 3P3W3M wiring modes. The 3P4W equations are also used as-is for Y-Δ conversion in 3P4W wiring mode.</p>						

Item	Wiring configuration					
	1P2W	1P3W	3P3W2M	3V3A	3P3W3M	3P4W
Fundamental wave active power	$P_{1(i)}$ of harmonic active power	$P_{1(i)(i+1)}$ of harmonic active power			$P_{1(i)(i+1)(i+2)}$ of harmonic active power	
Fundamental wave apparent power	$Sfnd_{(i)} = \sqrt{(P_{1(i)})^2 + (Q_{1(i)})^2}$	$Sfnd_{(i)(i+1)} = \sqrt{(P_{1(i)(i+1)})^2 + (Q_{1(i)(i+1)})^2}$			$Sfnd_{(i)(i+1)(i+2)} = \sqrt{(P_{1(i)(i+1)(i+2)})^2 + (Q_{1(i)(i+1)(i+2)})^2}$	
Fundamental wave reactive power	$Q_{1(i)} \times (-1)^{*1}$ of harmonic reactive power	$Q_{1(i)(i+1)} \times (-1)^{*1}$ of harmonic reactive power			$Q_{1(i)(i+1)(i+2)} \times (-1)^{*1}$ of harmonic reactive power	
Fundamental wave power factor	$\lambda fnd_{(i)} = si_{(i)} \cos \theta_{1(i)} $	$\lambda fnd_{(i)(i+1)} = si_{(i)(i+1)} \cos \theta_{1(i)(i+1)} $			$\lambda fnd_{(i)(i+1)(i+2)} = si_{(i)(i+1)(i+2)} \cos \theta_{1(i)(i+1)(i+2)} $	
<p>When equation Type 1 is selected, the polarity sign si is acquired based on the sign of the fundamental wave reactive power; if equation Type 3 is selected, based on the sign of the fundamental wave active power. When equation Type 2 is selected, results are unsigned.</p> <p>*1 When equation Type 2 is selected, take the absolute value.</p>						

Equations for motor analysis option

Measurement items	Setting	Equation
Voltage	Analog DC	$\frac{1}{M} \sum_{s=0}^{M-1} A_s$
Pulse frequency	Pulse	Pulse frequency
Torque	Analog DC	$\frac{1}{M} \sum_{s=0}^{M-1} A_s \times (\text{Scaling setting value})$
	Frequency	$\frac{[(\text{Measurement frequency}) - (f_c \text{ setting})] \times (\text{Rated torque value})}{f_d \text{ setting value}}$
RPM	Analog DC	$\frac{1}{M} \sum_{s=0}^{M-1} A_s \times (\text{Scaling setting value})$
	Pulse	$s_i \frac{60 \times (\text{Pulse frequency})}{(\text{Pulse count setting})}$ <p>If the direction of rotation detection is enabled in single mode, the polarity sign s_i is acquired based on the A-phase pulse's rising/falling edge and the B-phase pulse's logic level (high/low).</p>
Motor power	—	$(\text{Torque}) \times \frac{2 \times \pi \times (\text{RPM})}{60} \times (\text{Unit coefficient})$ <p>The unit coefficient is 1 if the unit of torque measurement is newton-meter (N•m), 1/1000 if it is millinewton-meter (mN•m), and 1000 if it is kilonewton-meter (kN•m).</p>
Slip	—	$100 \times \frac{2 \times 60 \times (\text{Input frequency}) - \text{RPM} \times (\text{Pole number setting})}{2 \times 60 \times (\text{Input frequency})}$ <p>The input frequency can be selected from among fU1 to fU8 and fL1 to fL8</p>
<p><i>M</i>: number of samples during synchronized timing period; <i>s</i>: sample number, <i>A</i>: analog waveform</p>		

Equations for harmonic measurement items

Item	Wiring configuration					
	1P2W	1P3W	3P3W2M	3V3A	3P3W3M	3P4W
Harmonic voltage	$U_{k(i)} = \sqrt{(U_{kr(i)})^2 + (U_{ki(i)})^2}$					
Harmonic voltage phase angle	$\theta U_{k(i)} = \tan^{-1} \left(\frac{U_{kr(i)}}{-U_{ki(i)}} \right)$					
Harmonic current	$I_{k(i)} = \sqrt{(I_{kr(i)})^2 + (I_{ki(i)})^2}$					
Harmonic current phase angle	$\theta I_{k(i)} = \tan^{-1} \left(\frac{I_{kr(i)}}{-I_{ki(i)}} \right)$					
Harmonic active power	$P_{k(i)} = U_{kr(i)} \times I_{kr(i)} + U_{ki(i)} \times I_{ki(i)}$			$P_{k(i)} = \frac{1}{3} (U_{br(i)} - U_{br(i+2)}) \times I_{br(i)} + \frac{1}{3} (U_{kb(i)} - U_{kb(i+2)}) \times I_{kb(i)}$ $P_{k(i+1)} = \frac{1}{3} (U_{br(i+1)} - U_{br(i)}) \times I_{br(i+1)} + \frac{1}{3} (U_{kb(i+1)} - U_{kb(i)}) \times I_{kb(i+1)}$ $P_{k(i+2)} = \frac{1}{3} (U_{br(i+2)} - U_{br(i+1)}) \times I_{br(i+2)} + \frac{1}{3} (U_{kb(i+2)} - U_{kb(i+1)}) \times I_{kb(i+2)}$		Same as 1P2W
	–	$P_{k(i)(i+1)} = P_{k(i)} + P_{k(i+1)}$			$P_{k(i)(i+1)(i+2)} = P_{k(i)} + P_{k(i+1)} + P_{k(i+2)}$	
Harmonic reactive power (used in internal calculations only)	$Q_{k(i)} = U_{kr(i)} \times I_{ki(i)} - U_{ki(i)} \times I_{kr(i)}$			$Q_{k(i)} = \frac{1}{3} (U_{br(i)} - U_{br(i+2)}) \times I_{kb(i)} - \frac{1}{3} (U_{kb(i)} - U_{kb(i+2)}) \times I_{br(i)}$ $Q_{k(i+1)} = \frac{1}{3} (U_{br(i+1)} - U_{br(i)}) \times I_{kb(i+1)} - \frac{1}{3} (U_{kb(i+1)} - U_{kb(i)}) \times I_{br(i+1)}$ $Q_{k(i+2)} = \frac{1}{3} (U_{br(i+2)} - U_{br(i+1)}) \times I_{kb(i+2)} - \frac{1}{3} (U_{kb(i+2)} - U_{kb(i+1)}) \times I_{br(i+2)}$		Same as 1P2W
	–	$Q_{k(i)(i+1)} = Q_{k(i)} + Q_{k(i+1)}$			$Q_{k(i)(i+1)(i+2)} = Q_{k(i)} + Q_{k(i+1)} + Q_{k(i+2)}$	
Harmonic voltage/current phase difference	$\theta_{k(i)} = \theta I_{k(i)} - \theta U_{k(i)}$					
	–	$\theta_{k(i)(i+1)} = \tan^{-1} \left(\frac{Q_{k(i)(i+1)}}{P_{k(i)(i+1)}} \right)$			$\theta_{k(i)(i+1)(i+2)} = \tan^{-1} \left(\frac{Q_{k(i)(i+1)(i+2)}}{P_{k(i)(i+1)(i+2)}} \right)$	
<ul style="list-style-type: none"> (i): measurement channel, k: analysis order, r: real part of FFT processed waveform, i: imaginary part of FFT processed waveform For the harmonic voltage phase angle and harmonic current phase angle, the fundamental wave of the harmonic synchronization source that serves as the phase reference is corrected to 0°. (However, this compensation is not performed when the harmonic synchronization source is set to Ext.) When the synchronization source is DC, the data update timing is defined as 0°. If the synchronization source is set to Ext, Zph, Ch. B or Ch. D, the rising edge or falling edge of the pulse used for synchronization is defined as 0°. For the harmonic voltage-vs.-current phase difference, each phase difference in 3P3W3M or 3P4W wiring mode is calculated based on the phase voltage, regardless of whether delta conversion is set to on or off. 						

10.5 Specifications of Equations

Item	Wiring configuration					
	1P2W	1P3W	3P3W2M	3V3A	3P3W3M	3P4W
Harmonic voltage content percentage	$Uhd_{k(i)} = \frac{U_k}{U_1} \times 100$					
Harmonic current content percentage	$Ihd_{k(i)} = \frac{I_k}{I_1} \times 100$					
Harmonic power content percentage	$Phd_{k(i)} = \frac{P_k}{P_1} \times 100$					
Total voltage harmonic distortion	$Uthd_{(i)} = \frac{\sqrt{\sum_{k=2}^K (U_k)^2}}{U_1} \times 100$ (with THD-F setting) of $\frac{\sqrt{\sum_{k=2}^K (U_k)^2}}{\sqrt{\sum_{k=1}^K (U_k)^2}} \times 100$ (with THD-R setting)					
Total harmonic current distortion	$Ithd_{(i)} = \frac{\sqrt{\sum_{k=2}^K (I_k)^2}}{I_1} \times 100$ (with THD-F setting) $\frac{\sqrt{\sum_{k=2}^K (I_k)^2}}{\sqrt{\sum_{k=1}^K (I_k)^2}} \times 100$ (with THD-R setting)					

(i): measurement channel, k: harmonic order, K: maximum analysis order (varies with synchronization frequency)

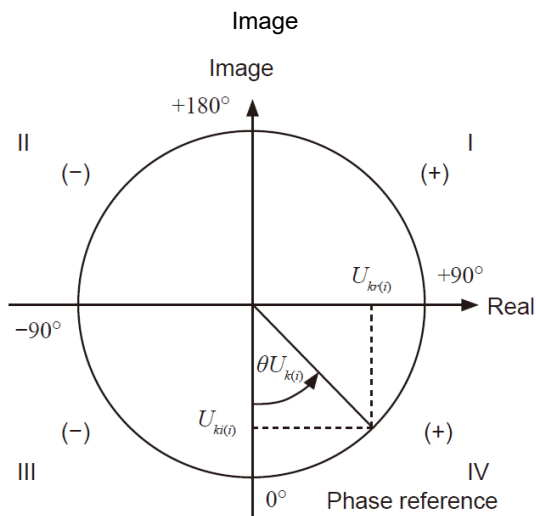

Example: for harmonic voltage

I	$\tan^{-1} \left(\frac{U_{kr(i)}}{-U_{ki(i)}} \right) + 180^\circ$
III, IV	$\tan^{-1} \left(\frac{U_{kr(i)}}{-U_{ki(i)}} \right)$
II	$\tan^{-1} \left(\frac{U_{kr(i)}}{-U_{ki(i)}} \right) - 180^\circ$
$U_{ki(i)} = 0, U_{kr(i)} < 0$	-90°
$U_{ki(i)} = 0, U_{kr(i)} > 0$	$+90^\circ$
$U_{ki(i)} < 0, U_{kr(i)} = 0$	0°
$U_{ki(i)} = 0, U_{kr(i)} = 0$	0°
$U_{ki(i)} > 0, U_{kr(i)} = 0$	$+180^\circ$

Equations for integration measurement

Item	Wiring configuration					
	1P2W	1P3W	3P3W2M	3V3A	3P3W3M	3P4W
WP+	$WP_{i+} = k \sum_1^h (P_i(+))$	$WP_{sum+} = k \sum_1^h (P_{sum}(+))$				
WP-	$WP_{i-} = k \sum_1^h (P_i(-))$	$WP_{sum-} = k \sum_1^h (P_{sum}(-))$				
WP	$WP_i = (WP_{i+}) + (WP_{i-})$	$WP_{sum} = (WP_{sum+}) + (WP_{sum-})$				
Ih+	$Ih_{i+} = k \sum_1^h (I_i(+))$	$Ih_{sum+} = k \sum_1^h (I_{sum}(+))$				
Ih-	$Ih_{i-} = k \sum_1^h (I_i(-))$	$Ih_{sum-} = k \sum_1^h (I_{sum}(-))$				
Ih	$Ih_i = (Ih_{i+}) + (Ih_{i-})$	$Ih_{sum} = (Ih_{sum+}) + (Ih_{sum-})$				
<p>h: measurement time, k: conversion coefficient for 1 h</p> <ul style="list-style-type: none"> (+): Only a positive (consumption) value is used. (-): Only a negative value (regeneration) value is used. 						

10.6 Specially Specified Combinatorial Accuracy With Optional Products for Current Measurement

For the following optional products for current measurement, the combinatorial accuracy with the PW4001 is specified specially.

For information on other specifications, see the instruction manuals for optional products for current measurement.

CT6841A

Frequency	Current, power		Phase
	% of the reading	% of the range	
DC	0.23	0.06	–
45 Hz ≤ f ≤ 65 Hz	0.23	0.02	PW4001 accuracy + sensor accuracy
Bands other than DC and 45 Hz ≤ f ≤ 65 Hz	PW4001 + sensor accuracy (full scale errors also take into account sensor ratings)		PW4001 accuracy + sensor accuracy

- The accuracies in this table only apply for the PW4001 data update intervals of 200 ms and 50 ms. For 10 ms or 1 ms: PW4001 accuracy + sensor accuracy (full scale errors also take into account sensor ratings)
- For other measurement items: PW4001 accuracy + sensor accuracy (full scale errors also take into account sensor ratings)
- For the 0.4 A range: Add ±0.36% of the range (range = PW4001 range).
- For the 0.8 A range: Add ±0.16% of the range (range = PW4001 range).
- For the 2 A range: Add ±0.05% of the range (range = PW4001 range).
- For the 4 A range: Add ±0.02% of the range (range = PW4001 range).
- Additions to accuracy are also applied based on the conditions of power analyzer and sensor specifications.

CT6843A

Frequency	Current, power		Phase
	% of the reading	% of the range	
DC	0.23	0.03	–
45 Hz ≤ f ≤ 65 Hz	0.23	0.02	PW4001 accuracy + sensor accuracy
Bands other than DC and 45 Hz ≤ f ≤ 65 Hz	PW4001 + sensor accuracy (full scale errors also take into account sensor ratings)		PW4001 accuracy + sensor accuracy

- The accuracies in this table only apply for the PW4001 data update intervals of 200 ms and 50 ms. For 10 ms or 1 ms: PW4001 accuracy + sensor accuracy (full scale errors also take into account sensor ratings)

10.6 Specially Specified Combinatorial Accuracy With Optional Products for Current Measurement

- For other measurement items: PW4001 accuracy + sensor accuracy (full scale errors also take into account sensor ratings)
- For the 4 A range: Add $\pm 0.16\%$ of the range (range = PW4001 range).
- For the 8 A range: Add $\pm 0.06\%$ of the range (range = PW4001 range).
- For the 20 A range: Add $\pm 0.01\%$ of the range (range = PW4001 range).
- Additions to accuracy are also applied based on the conditions of power analyzer and sensor specifications.

CT6833, CT6833-01

Frequency	Current, power		Phase
	% of the reading	% of the range	
DC	0.1	0.02	–
45 Hz \leq f \leq 65 Hz	0.1	0.017	PW4001 accuracy + sensor accuracy
Bands other than DC and 45 Hz \leq f \leq 65 Hz	PW4001 + sensor accuracy (full scale errors also take into account sensor ratings)		PW4001 accuracy + sensor accuracy

- The accuracies in this table only apply for the PW4001 data update intervals of 200 ms and 50 ms. For 10 ms or 1 ms: PW4001 accuracy + sensor accuracy (full scale errors also take into account sensor ratings)
- For other measurement items: PW4001 accuracy + sensor accuracy (full scale errors also take into account sensor ratings)
- For the 4 A range: Add $\pm 0.133\%$ of the range (range = PW4001 range).
- For the 8 A range: Add $\pm 0.048\%$ of the range (range = PW4001 range).
- For the 20 A range: Add $\pm 0.007\%$ of the range (range = PW4001 range).
- Additions to accuracy are also applied based on the conditions of power analyzer and sensor specifications.

CT6834, CT6834-01

Frequency	Current, power		Phase
	% of the reading	% of the range	
DC	0.1	0.02	–
45 Hz \leq f \leq 65 Hz	0.1	0.017	PW4001 accuracy + sensor accuracy
Bands other than DC and 45 Hz \leq f \leq 65 Hz	PW4001 + sensor accuracy (full scale errors also take into account sensor ratings)		PW4001 accuracy + sensor accuracy

- The accuracies in this table only apply for the PW4001 data update intervals of 200 ms and 50 ms. For 10 ms or 1 ms: PW4001 accuracy + sensor accuracy (full scale errors also take into account sensor ratings)
- For other measurement items: PW4001 accuracy + sensor accuracy (full scale errors also take into account sensor ratings)
- For the 10 A range: Add $\pm 0.133\%$ of the range (range = PW4001 range).

10.6 Specially Specified Combinatorial Accuracy With Optional Products for Current Measurement

- For the 20 A range: Add $\pm 0.048\%$ of the range (range = PW4001 range).
- For the 50 A range: Add $\pm 0.007\%$ of the range (range = PW4001 range).
- Additions to accuracy are also applied based on the conditions of power analyzer and sensor specifications.

CT6844A

Frequency	Current, power		Phase
	% of the reading	% of the range	
DC	0.23	0.03	-
$45 \text{ Hz} \leq f \leq 65 \text{ Hz}$	0.23	0.02	PW4001 accuracy + sensor accuracy
Bands other than DC and $45 \text{ Hz} \leq f \leq 65 \text{ Hz}$	PW4001 + sensor accuracy (full scale errors also take into account sensor ratings)		PW4001 accuracy + sensor accuracy

- The accuracies in this table only apply for the PW4001 data update intervals of 200 ms and 50 ms. For 10 ms or 1 ms: PW4001 accuracy + sensor accuracy (full scale errors also take into account sensor ratings)
- For other measurement items: PW4001 accuracy + sensor accuracy (full scale errors also take into account sensor ratings)
- For the 10 A range: Add $\pm 0.16\%$ of the range (range = PW4001 range).
- For the 20 A range: Add $\pm 0.06\%$ of the range (range = PW4001 range).
- For the 50 A range: Add $\pm 0.01\%$ of the range (range = PW4001 range).
- Additions to accuracy are also applied based on the conditions of power analyzer and sensor specifications.

CT6845A

Frequency	Current, power		Phase
	% of the reading	% of the range	
DC	0.23	0.03	-
$45 \text{ Hz} \leq f \leq 65 \text{ Hz}$	0.23	0.02	PW4001 accuracy + sensor accuracy
Bands other than DC and $45 \text{ Hz} \leq f \leq 65 \text{ Hz}$	PW4001 + sensor accuracy (full scale errors also take into account sensor ratings)		PW4001 accuracy + sensor accuracy

- The accuracies in this table only apply for the PW4001 data update intervals of 200 ms and 50 ms. For 10 ms or 1 ms: PW4001 accuracy + sensor accuracy (full scale errors also take into account sensor ratings)
- For other measurement items: PW4001 accuracy + sensor accuracy (full scale errors also take into account sensor ratings)
- For the 10 A range: Add $\pm 0.16\%$ of the range (range = PW4001 range).
- For the 20 A range: Add $\pm 0.06\%$ of the range (range = PW4001 range).
- For the 50 A range: Add $\pm 0.01\%$ of the range (range = PW4001 range).

10.6 Specially Specified Combinatorial Accuracy With Optional Products for Current Measurement

- Additions to accuracy are also applied based on the conditions of power analyzer and sensor specifications.

CT6846A

Frequency	Current, power		Phase
	% of the reading	% of the range	
DC	0.23	0.03	–
45 Hz ≤ f ≤ 65 Hz	0.23	0.02	PW4001 accuracy + sensor accuracy
Bands other than DC and 45 Hz ≤ f ≤ 65 Hz	PW4001 + sensor accuracy (full scale errors also take into account sensor ratings)		PW4001 accuracy + sensor accuracy

- The accuracies in this table only apply for the PW4001 data update intervals of 200 ms and 50 ms. For 10 ms or 1 ms: PW4001 accuracy + sensor accuracy (full scale errors also take into account sensor ratings)
- For other measurement items: PW4001 accuracy + sensor accuracy (full scale errors also take into account sensor ratings)
- For the 20 A range: Add ±0.16% of the range (range = PW4001 range).
- For the 40 A range: Add ±0.06% of the range (range = PW4001 range).
- For the 100 A range: Add ±0.01% of the range (range = PW4001 range).
- Additions to accuracy are also applied based on the conditions of power analyzer and sensor specifications.

CT6872, CT6872-01

Frequency	Current, power		Phase
	% of the reading	% of the range	
DC	0.06	0.012	–
45 Hz ≤ f ≤ 65 Hz	0.06	0.017	PW4001 accuracy + sensor accuracy
Bands other than DC and 45 Hz ≤ f ≤ 65 Hz	PW4001 + sensor accuracy (full scale errors also take into account sensor ratings)		PW4001 accuracy + sensor accuracy

- The accuracies in this table only apply for the PW4001 data update intervals of 200 ms and 50 ms. For 10 ms or 1 ms: PW4001 accuracy + sensor accuracy (full scale errors also take into account sensor ratings)
- For other measurement items: PW4001 accuracy + sensor accuracy (full scale errors also take into account sensor ratings)
- For the 1 A range: Add ±0.088% of the range (range = PW4001 range).
- For the 2 A range: Add ±0.028% of the range (range = PW4001 range).
- For the 5 A range: Add ±0.002% of the range (range = PW4001 range).
- Additions to accuracy are also applied based on the conditions of power analyzer and sensor specifications.

10.6 Specially Specified Combinatorial Accuracy With Optional Products for Current Measurement

CT6873, CT6873-01

Frequency	Current, power		Phase
	% of the reading	% of the range	
DC	0.06	0.012	–
45 Hz ≤ f ≤ 65 Hz	0.06	0.017	PW4001 accuracy + sensor accuracy
Bands other than DC and 45 Hz ≤ f ≤ 65 Hz	PW4001 + sensor accuracy (full scale errors also take into account sensor ratings)		PW4001 accuracy + sensor accuracy

- The accuracies in this table only apply for the PW4001 data update intervals of 200 ms and 50 ms. For 10 ms or 1 ms: PW4001 accuracy + sensor accuracy (full scale errors also take into account sensor ratings)
- For other measurement items: PW4001 accuracy + sensor accuracy (full scale errors also take into account sensor ratings)
- For the 4 A range: Add ±0.088% of the range (range = PW4001 range).
- For the 8 A range: Add ±0.028% of the range (range = PW4001 range).
- For the 20 A range: Add ±0.002% of the range (range = PW4001 range).
- Additions to accuracy are also applied based on the conditions of power analyzer and sensor specifications.

CT6904A, CT6904A-1

Frequency	Current, power		Phase
	% of the reading	% of the range	
DC	0.055	0.017	–
45 Hz ≤ f ≤ 65 Hz	0.05	0.017	PW4001 accuracy + sensor accuracy
Bands other than DC and 45 Hz ≤ f ≤ 65 Hz	PW4001 + sensor accuracy (full scale errors also take into account sensor ratings)		PW4001 accuracy + sensor accuracy

- The accuracies in this table only apply for the PW4001 data update intervals of 200 ms and 50 ms. For 10 ms or 1 ms: PW4001 accuracy + sensor accuracy (full scale errors also take into account sensor ratings)
- For other measurement items: PW4001 accuracy + sensor accuracy (full scale errors also take into account sensor ratings)
- For the 10 A range: Add ±0.133% of the range (range = PW4001 range).
- For the 20 A range: Add ±0.048% of the range (range = PW4001 range).
- For the 50 A range: Add ±0.007% of the range (range = PW4001 range).
- Additions to accuracy are also applied based on the conditions of power analyzer and sensor specifications.

CT6904A-2, CT6904A-3

10.6 Specially Specified Combinatorial Accuracy With Optional Products for Current Measurement

Frequency	Current, power		Phase
	% of the reading	% of the range	
DC	0.06	0.0172	–
45 Hz ≤ f ≤ 65 Hz	0.055	0.0172	PW4001 accuracy + sensor accuracy
Bands other than DC and 45 Hz ≤ f ≤ 65 Hz	PW4001 + sensor accuracy (full scale errors also take into account sensor ratings)		PW4001 accuracy + sensor accuracy

- The accuracies in this table only apply for the PW4001 data update intervals of 200 ms and 50 ms. For 10 ms or 1 ms: PW4001 accuracy + sensor accuracy (full scale errors also take into account sensor ratings)
- For other measurement items: PW4001 accuracy + sensor accuracy (full scale errors also take into account sensor ratings)
- For the 20 A range: Add ±0.1348% of the range (range = PW4001 range).
- For the 40 A range: Add ±0.0488% of the range (range = PW4001 range).
- For the 100 A range: Add ±0.0072% of the range (range = PW4001 range).
- Additions to accuracy are also applied based on the conditions of power analyzer and sensor specifications.

CT6875A

Frequency	Current, power		Phase
	% of the reading	% of the range	
DC	0.07	0.018	-
45 Hz ≤ f ≤ 65 Hz	0.07	0.018	PW4001 accuracy + sensor accuracy
Bands other than DC and 45 Hz ≤ f ≤ 65 Hz	PW4001 + sensor accuracy (full scale errors also take into account sensor ratings)		PW4001 accuracy + sensor accuracy

- The accuracies in this table only apply for the PW4001 data update intervals of 200 ms and 50 ms. For 10 ms or 1 ms: PW4001 accuracy + sensor accuracy (full scale errors also take into account sensor ratings)
- For other measurement items: PW4001 accuracy + sensor accuracy (full scale errors also take into account sensor ratings)
- For the 10 A range: Add ±0.142% of the range (range = PW4001 range).
- For the 20 A range: Add ±0.052% of the range (range = PW4001 range).
- For the 50 A range: Add ±0.008% of the range (range = PW4001 range).
- Additions to accuracy are also applied based on the conditions of power analyzer and sensor specifications.

10.6 Specially Specified Combinatorial Accuracy With Optional Products for Current Measurement

CT6876A, CT6876A-1

Frequency	Current, power		Phase
	% of the reading	% of the range	
DC	0.07	0.018	–
45 Hz ≤ f ≤ 65 Hz	0.07	0.018	PW4001 accuracy + sensor accuracy
Bands other than DC and 45 Hz ≤ f ≤ 65 Hz	PW4001 + sensor accuracy (full scale errors also take into account sensor ratings)		PW4001 accuracy + sensor accuracy

- The accuracies in this table only apply for the PW4001 data update intervals of 200 ms and 50 ms. For 10 ms or 1 ms: PW4001 accuracy + sensor accuracy (full scale errors also take into account sensor ratings)
- For other measurement items: PW4001 accuracy + sensor accuracy (full scale errors also take into account sensor ratings)
- For the 20 A range: Add ±0.142% of the range (range = PW4001 range).
- For the 40 A range: Add ±0.052% of the range (range = PW4001 range).
- For the 100 A range: Add ±0.008% of the range (range = PW4001 range).
- Additions to accuracy are also applied based on the conditions of power analyzer and sensor specifications.

CT6877A, CT6877A-1

Frequency	Current, power		Phase
	% of the reading	% of the range	
DC	0.07	0.018	–
45 Hz ≤ f ≤ 65 Hz	0.07	0.018	PW4001 accuracy + sensor accuracy
Bands other than DC and 45 Hz ≤ f ≤ 65 Hz	PW4001 + sensor accuracy (full scale errors also take into account sensor ratings)		PW4001 accuracy + sensor accuracy

- The accuracies in this table only apply for the PW4001 data update intervals of 200 ms and 50 ms. For 10 ms or 1 ms: PW4001 accuracy + sensor accuracy (full scale errors also take into account sensor ratings)
- For other measurement items: PW4001 accuracy + sensor accuracy (full scale errors also take into account sensor ratings)
- For the 40 A range: Add ±0.142% of the range (range = PW4001 range).
- For the 80 A range: Add ±0.052% of the range (range = PW4001 range).
- For the 200 A range: Add ±0.008% of the range (range = PW4001 range).
- Additions to accuracy are also applied based on the conditions of power analyzer and sensor specifications.

PW9100A-3, PW9100A-4

10.6 Specially Specified Combinatorial Accuracy With Optional Products for Current Measurement

Frequency	Current, power		Phase
	% of the reading	% of the range	
DC	0.05	0.017	–
45 Hz ≤ f ≤ 65 Hz	0.05	0.015	PW4001 accuracy + sensor accuracy
Bands other than DC and 45 Hz ≤ f ≤ 65 Hz	PW4001 + sensor accuracy (full scale errors also take into account sensor ratings)		PW4001 accuracy + sensor accuracy

- The accuracies in this table only apply for the PW4001 data update intervals of 200 ms and 50 ms. For 10 ms or 1 ms: PW4001 accuracy + sensor accuracy (full scale errors also take into account sensor ratings)
- For other measurement items: PW4001 accuracy + sensor accuracy (full scale errors also take into account sensor ratings)
- For the 1 A range: Add ±0.115% of the range (range = PW4001 range).
- For the 2 A range: Add ±0.04% of the range (range = PW4001 range).
- For the 5 A range: Add ±0.005% of the range (range = PW4001 range).
- Additions to accuracy are also applied based on the conditions of power analyzer and sensor specifications.

11

Maintenance and Service

11.1 Repair, Inspection, and Cleaning

WARNING



- **Do not attempt to modify, disassemble, or repair the instrument yourself.**
The internal components of the instrument may carry high voltages. Failure to follow this guidance could cause bodily injury or fire.

CAUTION



- **If the protective function of the instrument is damaged, arrange for immediate repair or dispose of it.**
- **If storage is unavoidable, label it as damaged.**
Failure to do so could result in bodily injury.

IMPORTANT

Halt use in the event of the following conditions.

- If the instrument is clearly damaged
- If the instrument is not capable of measurement
- If the instrument has been stored for an extended period of time in an undesirable environment, for example under conditions of high temperature and humidity
- If the instrument has been subjected to stress due to shipment under harsh conditions
- If the instrument is wet or soiled with a large amount of oil or dust (If the instrument gets wet or oil and dust get inside it, internal insulation may deteriorate, posing a significant risk of electric shock or fire.)
- If the instrument is unable to save measurement conditions

Calibration

The calibration interval depends on factors such as the operating conditions and environment. Please determine the appropriate calibration interval based on your operating conditions and environment and have Hioki calibrate the instrument accordingly on a regular basis.

Backing up data

When repairing or calibrating the instrument, we may initialize it. It is recommended to back up (save/write) data such as the settings and measured data before requesting service.

Replaceable parts and service life

Some parts used in the instrument are characterized by performance that degrades over years of use. It is recommended to replace these parts regularly to ensure instrument functionality over the long term. To order replacements, please contact your authorized Hioki retailer or reseller. The service life of parts varies with the operating environment and frequency of use. These parts are not guaranteed to operate throughout the period defined by the recommended replacement interval.

Parts	Service life	Remarks and conditions
Electrolytic capacitor	About 10 years	Requires replacement of the printed circuit boards on which such parts are mounted.
Liquid crystal backlight (half life period of brightness)	About 50,000 hours	At an ambient temperature of 25°C (77°F)
Fan motor	About 10 years	At an ambient temperature of 23°C (73°F)
Backup battery	About 10 years	At an ambient temperature of 23°C (73°F) Requires replacement if the time and date are significantly deviated when the instrument is turned on.

Replacing fuses

The instrument's power supply has a built-in fuse. If the instrument cannot be turned on, the fuse may have blown. Fuses cannot be repaired or replaced by the customer. Please contact your authorized Hioki retailer or reseller.

Cleaning

PW4001 main body



CAUTION

- **Periodically clean the vents.**

When the vents become clogged, the internal cooling effect of the instrument is hampered, and this can lead to damage to the instrument.

- **To clean the instrument, wipe it using a soft cloth moistened with water or a neutral detergent.**



Using solvent-containing detergents, such as benzine, alcohol, acetone, ether, ketone, thinner, and gasoline, or wiping the product with excessive force could cause deformation or discoloration.

- **Gently wipe the touchscreen with a dry, soft cloth or a soft cloth soaked in ethanol. Do not use hard cloths, organic solvents, acids or alkalis.**







Doing so may cause the panel to become scratched, deformed, or discolored, causing it to not function properly.

11.2 Troubleshooting

If damage is suspected, refer to “Before Returning for Repair” (p.395) and “11.3 Error messages” (p.398) to address the issues. If the issue cannot be resolved, please contact your authorized Hioki retailer or reseller.

Before Returning for Repair

Check the following items.

Issue	Cause	Solution and where to find additional information
The time and date significantly deviated after the instrument was turned on.	The backup battery needs replacing. A backup lithium battery is installed in the instrument. The service life of the backup battery is about 10 years.	If the battery requires replacement, the battery cannot be replaced by the customer. Please contact your authorized Hioki retailer or reseller.
Nothing is shown on the screen when the power is turned on.	The power cord is not connected to the instrument. The power cord is improperly connected.	Verify that the power cord is connected properly.  See “2.4 Supplying Power to the Instrument” (p.60)
The keys are not functioning.	The instrument is in the key-lock state.	Press and hold the REMOTE/LOCAL key for at least 3 s to cancel the key-lock state.
The screen does not react even when you use the touchscreen.	The instrument is in the key-lock state. Foreign material, such as dust, settles on the touchscreen. The touch panel position has shifted.	<ul style="list-style-type: none"> Press and hold the REMOTE/LOCAL key for at least 3 s to cancel the key-lock state. Remove the dust or other foreign material.  See “Replaceable parts and service life” (p.394)  See “Touch panel calibration” (p.194)
The instrument’s settings cannot be changed.	The instrument is performing integration or stopped performing integration.	Perform an integrated value reset (data reset).  See “3.3 Integration Measurement” (p.98)
The instrument cannot display any measured voltage or current values.	The voltage cords and current sensors are improperly connected.	Check the connections.  See “2 Preparing for measurement” (p.51)
	The input channel and display channel do not match with each other. (For example, this issue will arise if the input channel has been set to Ch. 1 while a page other than the CH1 page has been displayed.)	Use the ◀ CH ▶ keys for channel selection to display the page for the input channel.  See “3.2 Measuring Power” (p.84)
The active power is not displayed.	The voltage and current range settings are improperly configured.	Set the voltage and current ranges properly.  See “Voltage range and current range” (p.86)

11.2 Troubleshooting

Issue	Cause	Solution and where to find additional information
Frequency cannot be measured, or measured values are unstable.	The input frequency is set outside the range of 0.1 Hz to 500 kHz.	Check the frequency by viewing the input waveform. See "4.1 Waveform Display Method" (p.149)
	The input frequency is lower than the set frequency.	Set the measurement lower frequency limit setting. See "Measurement upper frequency limit and lower frequency limit (configuring frequency measuring range)" (p.94)
	The synchronization source input is incorrect. The synchronization source input range is too large.	Check the synchronization source setting. See "Synchronization source" (p.91) See "Voltage range and current range" (p.86)
	A severely distorted waveform, such as a PWM waveform, is measured.	Set the zero-cross filter to ON. See "ZCF (Zero-cross filter)" (p.157)
Three-phase voltage measurement results are low.	Phase voltages are measured with the Δ -Y conversion function.	Turn off the Δ -Y conversion function. See " Δ -Y conversion" (p.175)
Measured power values are anomalous.	The instrument is incorrectly connected.	Check the instrument's connection. See "2.10 Checking Connections" (p.78)
	The rectifier and LPF settings is improperly configured.	Set the rectifier properly. If the LPF is enabled, set it to OFF. See "Rectification method" (p.96) See "Low-pass filter (LPF)" (p.93)
The current reading never falls to zero even when receiving zero-input.	A Universal Clamp On CT is used with a lower current range. The current sensor's high-frequency noise may be affecting the current reading.	Perform zero adjustment after setting the LPF to 100 kHz. See "Low-pass filter (LPF)" (p.93) See "2.9 Connecting Measurement Leads and Sensors to Lines to Be Measured" (p.75)
The apparent power, reactive power, and power factor readings on the secondary-side of an inverter differ from measurements obtained using other instruments. Voltage values are higher than expected.	The rectifier settings are not the same as those on the other instruments.	Use the same rectifier setting as with the other instruments. See "Rectification method" (p.96)
	The calculation methods differ.	Use the same calculation methods as with the other instruments. See "5.6 Power calculation method" (p.179)
Motor RPM cannot be measured.	The pulse output is set to other than voltage output. The instrument cannot detect open collector pulse output.	Set the device to voltage output to match the Ch. B pulse input setting.
	The pulse output contains noise.	Check the cable routing. Ground the encoder that generate the pulse output. Specify the pulse-noise filter (PNF). See "Pulse-noise filter (PNF)" (p.133)

Issue	Cause	Solution and where to find additional information
A large value exceeding the display range was recorded in the saved data.	An overload condition occurs.	Set an appropriate range. 🔍 See “4.1 Waveform Display Method” (p.149) 🔍 See “7.10 Measured Value Save Data Format” (p.228)
A large value exceeding the display range was recorded in the saved data. Large values such as [1.00E+104] or [7.78E+103] are included in the stored data.	The string [-----] is displayed because overload or peak overload has occurred, the range has been changed, or the measured value is invalid.	Set an appropriate range. 🔍 See “4.1 Waveform Display Method” (p.149) 🔍 See “7.10 Measured Value Save Data Format” (p.228) Do not change the range while saving data. Alternatively, treat it as invalid data.
The instrument cannot detect a USB flash drive.	The USB flash drive is damaged.	Press the reload button () on the [FILE] screen. Cycle the instrument.

If the cause of your problem remains unclear

If you are unsure of the cause, try a system reset.

All settings will be returned to their factory defaults.





[🔍 See “6 System Settings” \(p.189\)](#)

11.3 Error messages

- If damage is suspected, refer to “Before Returning for Repair” (p.395) and “Error messages” (p.398) to address the issues. If the issue cannot be resolved, please contact your authorized Hioki retailer or reseller.
- When an error is displayed, the instrument needs repair. Please contact your authorized Hioki retailer or reseller.
- Turning on the instrument while the lines to be measured are live may damage the instrument or cause an error to be displayed. Always turn the instrument on first and then activate power to the lines to be measured once you have verified that no error is being displayed by the instrument.



Message	Remedy
The option calibration data is corrupted.	The instrument is in need of repair. Please contact your authorized Hioki retailer or reseller.
The option configuration has changed.	
The unit calibration data is corrupted.	
The unit ID setting is incorrect.	
The instrument’s settings have been initialized.	If this message appears frequently, the instrument may be in need of repair. Please contact your authorized Hioki retailer or reseller.
The fan is broken. The system will shut down after 3 minutes due to a risk of overheating or malfunction.	The instrument is in need of repair. Please contact your authorized Hioki retailer or reseller.
Communication part of the Unit is broken.	
The internal memory cannot be recognized. It may be damaged.	If restarting the device does not improve the situation, it is in need of repair. Please contact your authorized Hioki retailer or reseller.

11.4 Warning messages

Message	Remedy	Reference
<p>The current sensor and wiring settings have changed. Settings can be restored by switching back to the current sensor below and pressing the Restore button. Caution: The restore will fail if the current sensor is different from the following.</p>	<p>If the current sensor was changed intentionally, tap the [OK] box to close the message.</p>	–
<p>Holding values...</p>	<p>While the hold function is activated, settings that affect measured values cannot be changed. If you wish to change settings, disable the hold function.</p>	<p> See “5.3 Hold function” (p.171)</p>
<p>Holding peak values...</p>	<p>While the peak hold function is activated, settings that affect measured values cannot be changed. If you wish to change settings, disable the peak hold function.</p>	<p> See “5.4 Peak hold function” (p.173)</p>
<p>Integration is ongoing, the instrument is standing by for integration, or integration is stopped.</p>	<p>If you want to reset integration while the instrument is integrating or standing by for integration, stop the integration, then press the DATA RESET key. During the integration, settings that affect other measured values cannot be changed.</p> <p>If you want to reset integration while integration has been stopped, press the DATA RESET key.</p>	<p> See “3.3 Integration Measurement” (p.98)  See “Integration measurement while using the time control function” (p.104)</p>
<p>The entered value is out of range. Please check the setting range and enter the value again.</p>	<p>Check the setting range and enter the value again.</p>	–
<p>Unable to switch wiring. The wiring includes one or more different current sensors.</p>	<p>Check the current sensor connection.</p>	<p> See “2.5 Setting Wiring Mode and Configuring Current Sensor Settings” (p.66)</p>
<p>The number of parameters that can be saved has been exceeded. Check the setting.</p>	<p>Set the data save interval to longer than the present setting or reduce the number of items to be saved.</p>	–
<p>Cannot perform zero adjustment.</p>	<p>Zero adjustment cannot be performed during hold, peak hold, or integration. To perform zero adjustment, cancel hold and peak hold, and reset the integration.</p>	–
<p>Out of the input range.</p>	<p>Check the setting range and enter the value again.</p>	–

11.4 Warning messages

Message	Remedy	Reference
The integration start time is in the past.	Check the integration start time of real time control.	🔍 See “5.1 Time Control Function” (p.165)
Unable to switch I input. The wiring includes one or more different current sensors.	Check the current sensor connection.	🔍 See “2.5 Setting Wiring Mode and Configuring Current Sensor Settings” (p.66)
Failed to delete.	Try again.	–
Failed to load the upgrade file.	The version-up file may be corrupt. Copy the version-file again and execute it.	–
There is not enough space on the media.	Delete any unnecessary files or change the media.	🔍 See “7.3 Data Save Destination” (p.203) 🔍 See “7.9 File and Folder Operation” (p.225)
Unable to automatically generate the filename.	Either specify a different destination folder or create a new folder and save the file in it. Otherwise, delete unnecessary files or replace the USB flash drive with another one.	🔍 See “7.9 File and Folder Operation” (p.225)
The name is already being used by a different file or folder.	Use another name for the file or folder.	🔍 See “Renaming a file or folder” (p.225)
Unable to find the media.	Confirm that the media to be saved to is recognized.	🔍 See “7.3 Data Save Destination” (p.203)
Unable to switch to the wiring described in the settings file due to differences in the sensor configuration.	The instrument cannot load a configuration file if the combination of options differs from the actual combination.	🔍 See “7.8 Saving and Loading the Settings Data” (p.223)
Unable to load the settings data. The option configuration is different.		–
Unable to load the settings data. The unit configuration is different.		–
The instrument's firmware version differs from the version for which the settings data was created.		–
Unable to load the settings file.	Put the instrument into an integration reset state, and a hold canceled state, and disable the synchronous control.	–
Failed to write data.	Try again.	–
Failed to load data.		–
Unable to create file.		–
Unable to create folder.		–
This USB flash drive is not supported and cannot be used with this instrument.	If the USB flash drive is formatted with a non-FAT file system, reformat it with FAT32.	🔍 See “7.2 USB flash drive” (p.201)

Message	Remedy	Reference
Unable to access the USB drive.	The instrument may not support the USB flash drive. Check that the instrument is compatible with the USB flash drive. Even if the instrument should support your USB flash drive, format it when it is not accessible.	<p> See “USB flash drive requirements for this instrument” (p.201)</p> <p> See “Formatting a USB flash drive or the internal memory” (p.227)</p>
No files were found for automatic FTP upload.	Check if there is a file to be sent.	–
Failed to copy data.	Try again.	–
The file on the device is being accessed.	If the instrument is automatically saving data, stop it. If the FTP server function is in use, disconnect the connection.	–
Auto-save operation has not completed. Reset the instrument.	Stop the auto-save operation.	–
Failed to rename.	You cannot rename a file the same as other files or leave the filename box blank. Enter a different name.	–
Failed to format.	Try again.	–
Sequential FILE screen processing is not possible while auto-save operation is in progress. Wait a moment.	Wait a moment.	–
Unable to execute screenshot while Auto-save operation.	Set the data save interval to 1 s or more. Alternatively, stop the auto-save operation.	–
Unable to save measured data manually while Auto-save operation.	Stop the auto-save operation.	–
Unable to save waveform data while Auto-save operation.		–
Unable to save settings data while Auto-save operation.		–
Unable to execute media operation while Auto-save operation.		–
Unable to make DBC file while Auto-save operation.		–
Unable to make UDF settings file while Auto-save operation.		–
Unable to make A2L file while Auto-save operation.		–
Unable to mount FTP server while Auto-save operation.		–

11.4 Warning messages

Message	Remedy	Reference
Failed to send the FTP file. It will be resent after a certain period of time.	Make sure that the FTP server is running. Otherwise, check the FTP client settings.	🔍 See “9.5 Sending Data Using the FTP Client Function” (p.298)
Failed to resend the FTP file.		–
Unable to send file. Too many unsent files.	Wait while files are sent.	–
Saved in a file. Wait a moment.	Wait a moment.	–
Unable to save data while storing waveform.	Record the waveforms with the SINGLE key and then save them.	🔍 See “4.3 Recording Waveforms” (p.159)
The waveform and settings are inconsistent. Please update with the SINGLE key and try again.		
Operating in the IEC measurement mode.	Unavailable in IEC measurement mode. Set the measurement mode to wideband measurement mode.	🔍 See “2.7 Measurement mode” (p.72)
Operating in or waiting for the BNC synchronization mode.	Unavailable during BNC synchronization mode or in the connection-ready state. Turn the BNC-sync setting off or restore the BNC synchronization.	🔍 See “BNC synchronization” (p.339) in “External interface specifications”
Operating in the BNC synchronization secondary mode.	Unavailable during the BNC-sync secondary operation. Turn the BNC-sync setting off.	
If conditions prevent UDF from being calculated, it will also not be possible to calculate efficiency and loss. In such a case, revise the UDF settings.	Confirm that the specified UDF can be calculated.	🔍 See “3.5 Measuring efficiency and loss” (p.116)
The specified efficiency or loss item cannot be calculated because the calculation settings include UDF.	Do not include UDF in the calculation settings for the specified efficiency or loss item.	
Unable to load because it is not a PW4001 configuration file.	Recreate the UDF configuration file.	🔍 See “Loading user-defined formula (UDF) setting data” (p.184)
Unable to load some settings.		
Cannot set because of the invalid combination.	Set [Data speed] to be equal to or higher than [Arbitration speed] .	🔍 See “Setting CAN output” (p.257)
Cannot set because the number of items has exceeded the limit.	Reduce the number of items selected.	
Unable to output arbitrary frames because the data update interval is 1 ms.	Set the data update interval to a value other than 1 ms.	🔍 See “Data update interval” (p.89)

Message	Remedy	Reference
Unable to output arbitrary frames because all settings for using arbitrary frames are turned off.	Turn ON [✓] the [Use] setting for at least one setting for arbitrary frame output.	See “8.5 Arbitrary Frame Output Function” (p.266)
A PID with a different number of response bytes is included. Make sure that the number of response bytes is the same for each PID type.	Specify the same number of response bytes for each PID type.	See “Diagnostic measurement setup procedure” (p.275)
The measurement ECU’s ID specification is out of range.	Specify a valid ID value.	
The factor or offset value is outside the valid input range.	Specify a value in the range of 999.999T to -999.999T.	
The license key file format is different. Confirm the filename and file format.	Confirm the filename and file format.	See “11.12 Adding Optional Functions” (p.416)
This added function is not supported by this product or by the current version. Update the version and try again.	Update the version and try again.	
The authentication credentials did not match. Confirm the serial number and expiration date.	Confirm the serial number and expiration date. If they match but the error still appears, please contact your authorized Hioki retailer or reseller.	

11.5 Frequently Asked Questions

The instrument has saved no measured data even though I measured with the auto-save setting. What should I do?

Do not press the **RUN/STOP** key but the **START/STOP** key to perform the auto-save measurement.

🔍 See “Automatically saving measured data” (p.212)

The message “Unable to automatically generate the filename.” has appeared during the auto-save operation. What should I do?

Create another folder to save further files.

Each folder can contain up to 1000 files.

🔍 See “Recordable time and data” (p.214)

My computer has failed to acquire the MAC address even though I have connected the instrument to the computer through our LAN. What should I do?

Check the IP address settings.

Except for the last three digits of the IP address, communications cannot be performed unless all the IP addresses are set to the same numbers as the computer’s IP address.

🔍 See “9.2 LAN Connections and Settings” (p.288)

The saved data includes unusual values, such as 1.00E+104 and 7.78E+103. What does this mean?

The value 1.00E+104 indicates that the data is overloaded or peaked. The value 7.78E+103 indicates that [-----] is displayed due to range change or operation disabled value.

The instrument outputs data of +99999.9E+99 and +77777.7E+99 for the values 1.00E+104 and 7.78E+103, respectively. These data are displayed after being changed to the notation (number of digits, etc.) according to the data format of the software used to display data.

🔍 See “7.10 Measured Value Save Data Format” (p.228)

Can I use password-protected (secure) USB flash drives with the instrument?

Password-protected USB flash drives cannot be used the instrument.

Use USB flash drives that accommodate the mass storage class standard.

🔍 See “7.2 USB flash drive” (p.201)

The instrument failed to detect my USB flash drive. What should I do?

Cycle the instrument. If the instrument cannot recognize the USB flash drive after the instrument was cycled, try a different USB flash drive. (Not all USB flash drives are supported.)

🔍 See “7.2 USB flash drive” (p.201)

11.6 Calculation of the Combinatorial Accuracy

If the combinatorial accuracy of PW4001 and the sensor is not specified

The measurement accuracy for the active power and current is the sum of the accuracy of the instrument and the current sensor to be used.

For example, measurement accuracy of active power can be calculated from the following equations:

(Reading accuracy) = (Reading accuracy of active power) + (Reading accuracy of sensors)

(Range accuracy) = (Range accuracy of active power) + [(Sensor's rated current) / (Current range)] × (Full-scale accuracy of sensor)

Sensor	CT6862 (rated current: 50 A), accuracy $\pm 0.05\%$ of reading $\pm 0.01\%$ of full scale
Instrument setting	Power range: 6.00000 kW, accuracy $\pm 0.03\%$ of reading $\pm 0.01\%$ of range Wiring: 1P2W Voltage range: 600 V Current range: 10 A
Object under measurement	400 V, 5 A, 2.00000 kW, 50 Hz

Reading accuracy = 0.03% of reading + 0.05% of reading = $\pm 0.08\%$ of reading

Range accuracy = 0.01% of range + (50 A / 10 A) × 0.01% of full scale = $\pm 0.06\%$ of range

The accuracy for active power is $\pm 0.08\%$ of reading and $\pm 0.06\%$ of range (with power range 6 kW).

11.7 External view

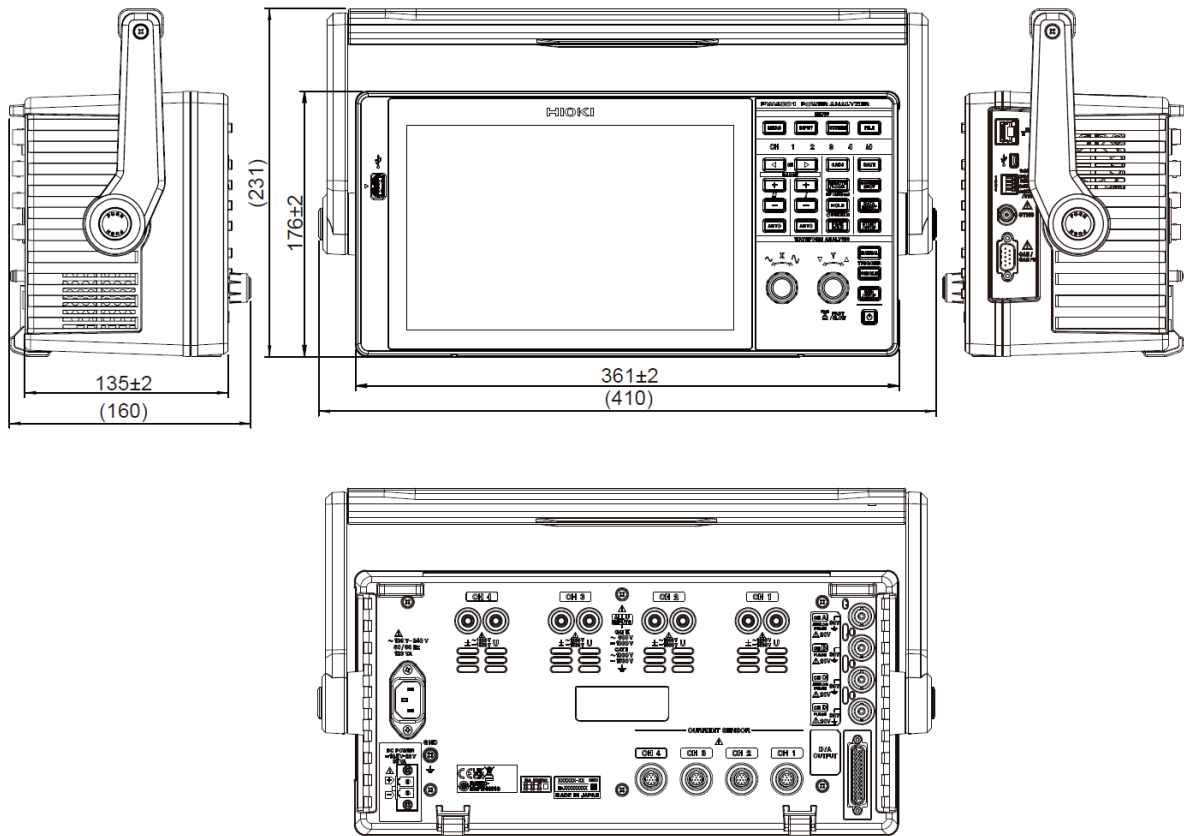

(Unit: mm)

11.8 Rackmount fittings

The instrument can be installed using rackmount fittings (optional).

JIS-compliant rackmount fitting

(Unit: mm)

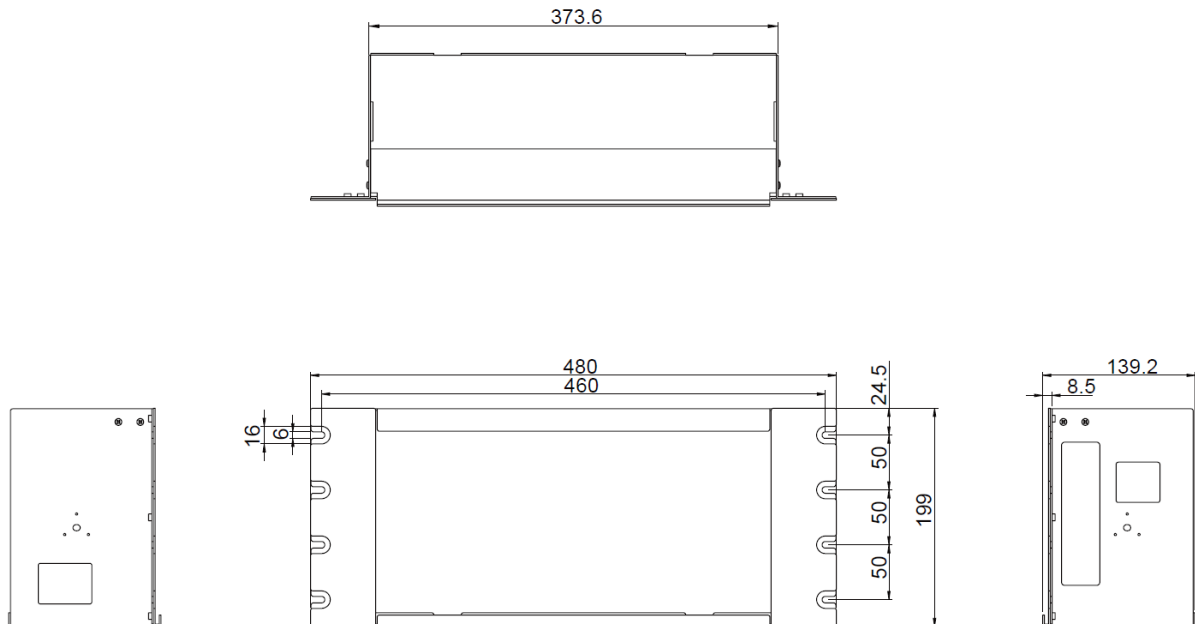

EIA-compliant rackmount fitting

(Unit: mm)

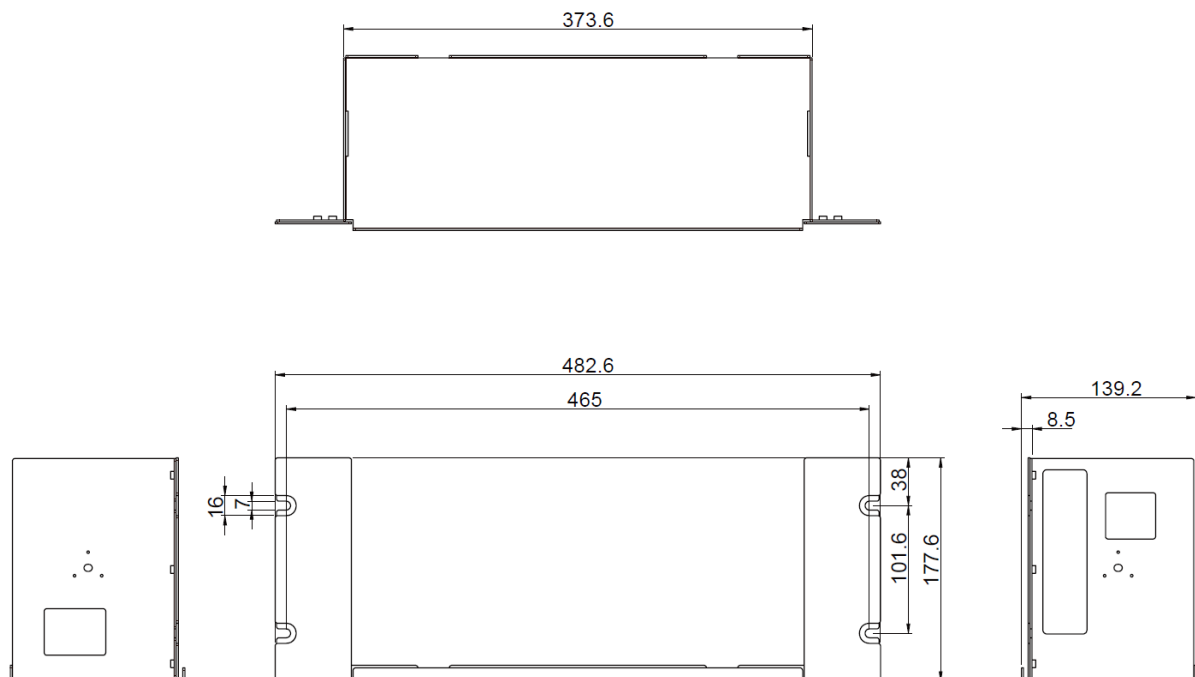

Installation instructions

WARNING

- Use the screws included with the rackmount fittings to secure the PW4001 main unit and rackmount fittings.



- When removing the rackmount fittings from the instrument and returning it to its original position, secure the handles in place with the screws attached to the instrument at the time of shipment.

Using any other screws could damage the instrument, resulting in bodily injury.

If any screw is lost or damaged, please contact your authorized Hioki retailer or reseller.

Tools to be prepared:

- Rackmount fittings (JIS-compliant: Z5303, EIA-compliant: Z5302)
- Phillips screwdriver (No. 2)
- Flat-head screwdriver

If mounting the instrument to a JIS-compliant rack

- 1 Remove the handle caps and screws.

The caps are secured with double-sided tape. Use a flat-head screwdriver to peel off the adhesive surface.

Use a Phillips screwdriver to remove the screws. Store the caps and screws together with the handle.

- 2 Spread open the handle and remove it from the main unit.

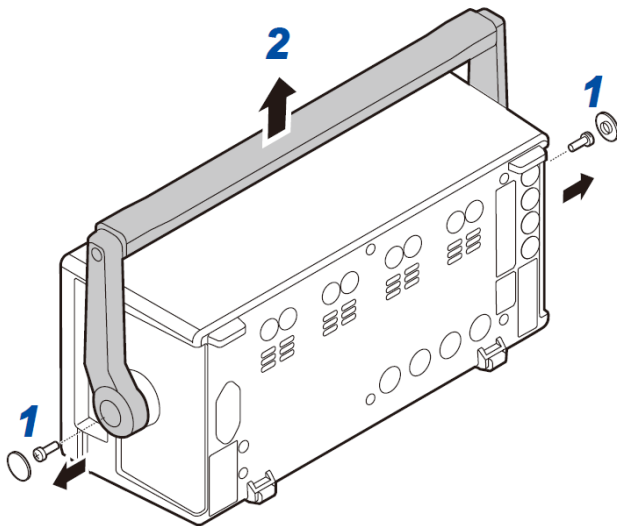

- 3 Attach the rackmount fittings to the main unit.

Use the Phillips screwdriver to attach using the M5×10 screws (included, one for each side).

- 4 Use the Phillips screwdriver to attach the connecting rackmount fittings with the M3×6 screws (included, two for each side).

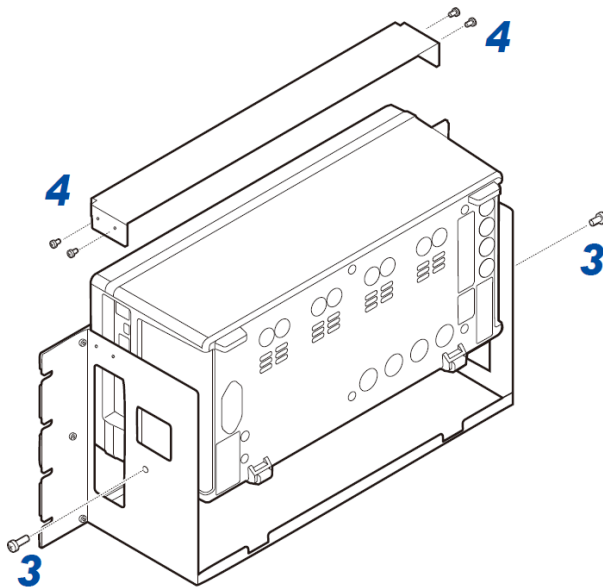

If mounting the instrument to an EIA-compliant rack

- 1** Remove the handle caps and screws.

The caps are secured with double-sided tape. Use a flat-head screwdriver to peel off the adhesive surface.

Use a Phillips screwdriver to remove the screws. Store the caps and screws together with the handle.
- 2** Spread open the handle and remove it from the main unit.

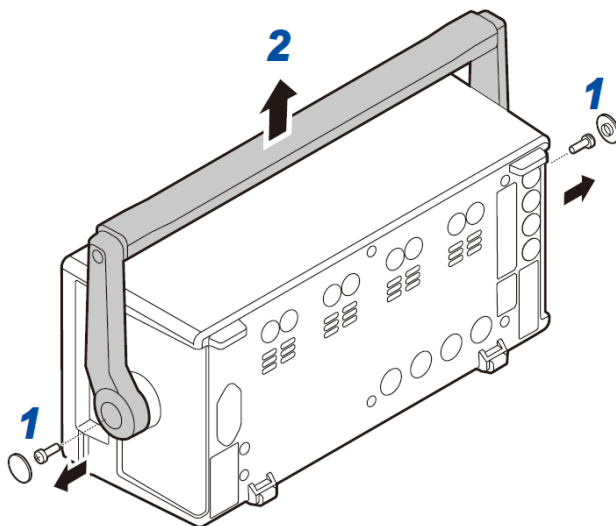

- 3** Attach the rackmount fittings to the main unit.

Use the Phillips screwdriver to attach using the M5×10 screws (included, one for each side).

11.8 Rackmount fittings

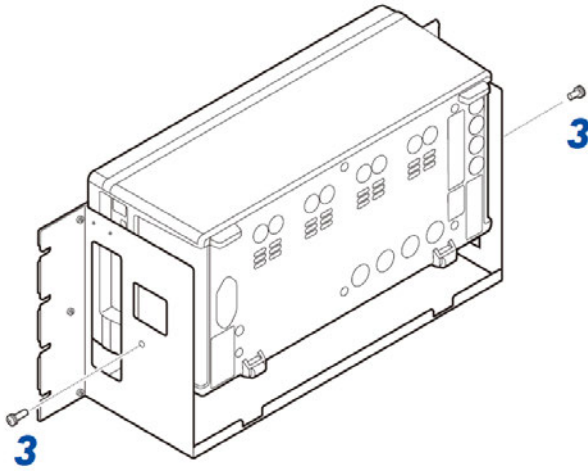

11.9 About Technical Information

Examples of technical information related to Hioki Power Analyzer are shown below. Please download this information from Hioki's website.

- Effectiveness of Current Sensor Phase Shift When Evaluating the Efficiency of High-efficiency Motor Drives
- Measurement of Loss in High-Frequency Reactors
- High-precision Power Measurement of SiC Inverters
- Current Measurement Methods that Deliver High Precision Power Analysis in the Field of Power Electronics
- Identification of PMSM Motor Parameters with a Power Analyzer
- Identification of PMSM Parameters with the Power Analyzer PW8001
- Real Operating Loss Measurement of Low-Loss Inductors Using High-Precision Wideband Power Analyzer and Current Sensor
- High-precision, Wideband, Highly Stable Current Sensing Technology

11.10 Block Diagram

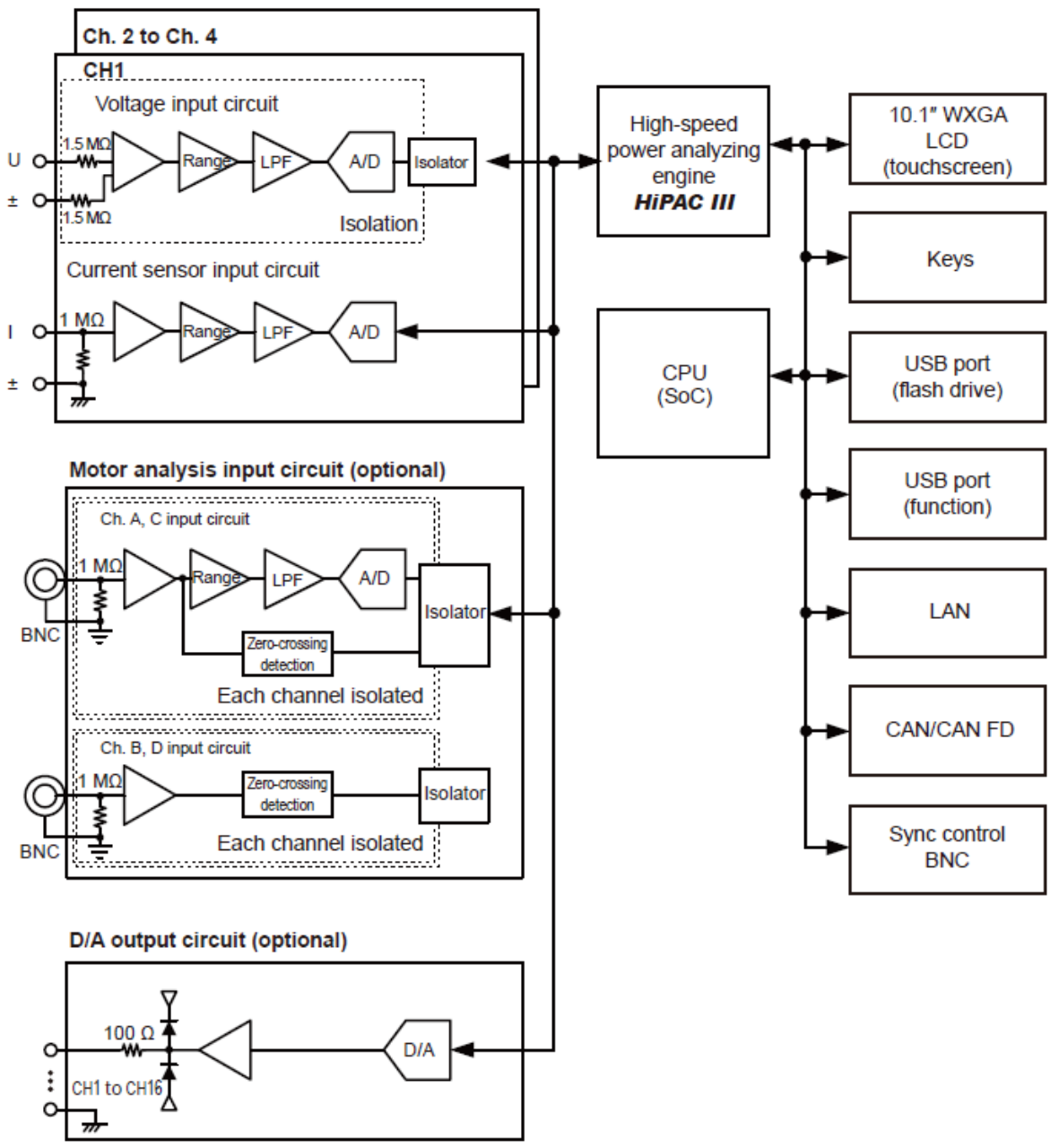

11.11 Updating the Firmware

IMPORTANT

- Updating the firmware will take about 5 minutes. Do not turn off the instrument until updating is completed. Turning off the instrument during the process will cause it to malfunction. In such a case, contact your authorized Hioki distributor or reseller for repair.
- It is recommended that you save a backup copy of your configuration conditions before updating the firmware.

1 Access our website and download the version upgrade file (PW4001_Vxxx.VER).

The letters “xxx” represent the version number.

(e.g., 120 for Ver. 1.20)

🔍 See “Information on download site” (p.7)

2 Save the version upgrade file to the HIOKI/PW4001/ directory on a USB flash drive.

3 Press the **FILE** key to move to the file operation screen.

4 Insert a USB flash drive into the instrument’s USB connector.

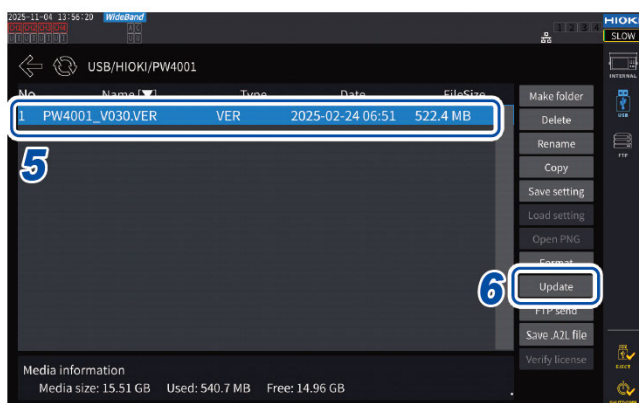

5 Tap the version upgrade file to select it.

6 Tap **[Update]**.

The confirmation window is displayed.

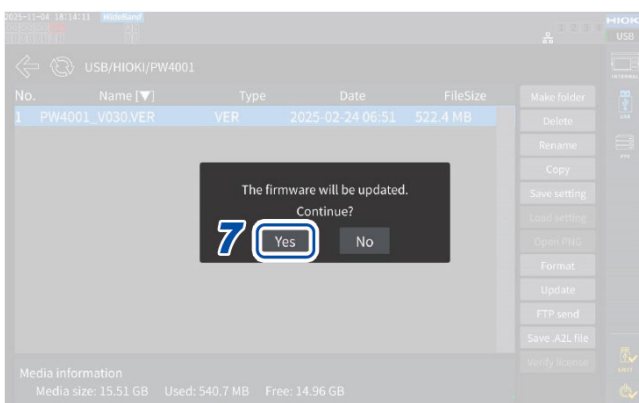

7 Tap **[Yes]**.

11.11 Updating the Firmware

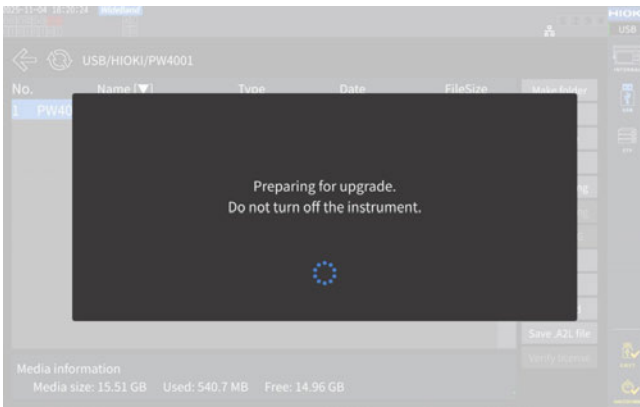

The window appears, indicating that an upgrade is being prepared.

After the window closes, the screen display disappears, and the firmware update begins.

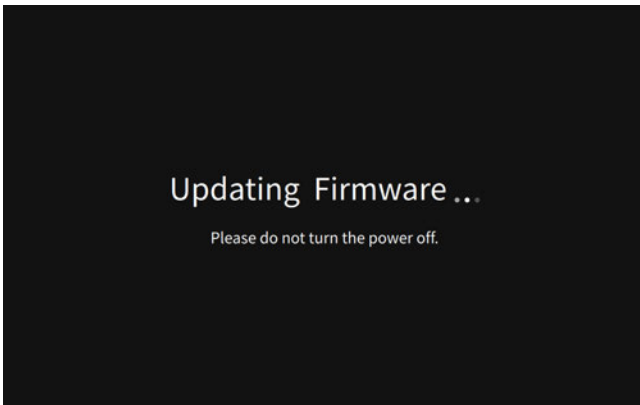

The message **[Updating Firmware...]** is displayed, and the instrument starts up.

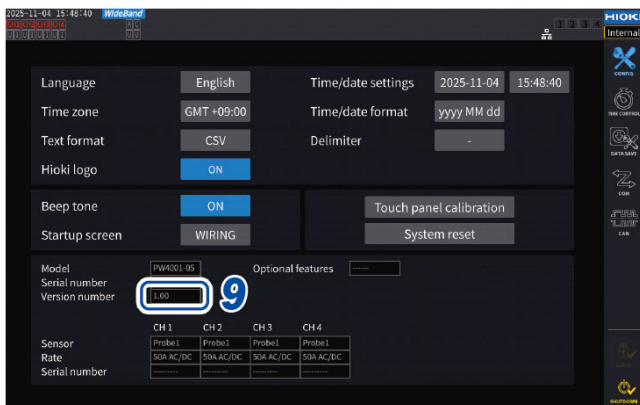

8 Press the **SYSTEM** key.

9 Check that the version number is correct on the **[CONFIG]** screen.

The following applications and functions can also be used to update the firmware without using a USB flash drive.

Application/Function	Overview
GENNECT One	Automatically update using GENNECT One. Q See “9.8 GENNECT One (PC Application Software)” (p.311)
HTTP remote operation	Automatically update using HTTP remote operation. Q See “9.3 Remotely Operating the Instrument Through the HTTP Server” (p.292)
FTP server	Manually update by transferring update files using the FTP server function. Q See “9.4 Acquiring Data through the FTP Server” (p.295)

GENNECT One

See the “GENNECT One User’s Manual (PDF)” for information on updates. Select Help on the GENNECT One information menu to display the manual.

HTTP remote operation

- 1 Click **[Control Mode]**.

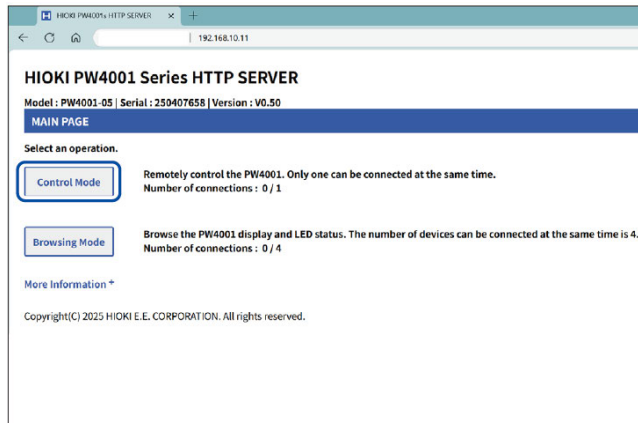

- 2 Click **[Remote Update]**.



- 3 Click **[Open...]** and select the update file.

- 4 Click **[UPDATE]**.

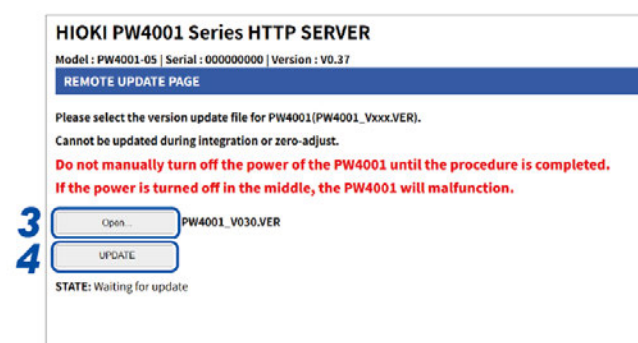

11.12 Adding Optional Functions

By purchasing additional optional licenses, the PW4001's functions can be expanded as follows.

Model name	Function overview	Target version
PW9006	IEC harmonics/flicker measurement function	V1.10 and later

Once expanded, optional functions will not be deleted even by a system reset or boot key reset.

Issuing a license key (performed on a computer)

- 1** Access the download site.
 See "Information on download site" (p.7)
- 2** Log into the download site.
You must log in to issue a license key. If you don't have an account, please create a new account.
- 3** Search for the model name of the optional function and click on it.

- 4 Input the registration code printed on your license card (1) to issue the license key.

For instructions on issuing a license key, refer to the Help section of the download site.

To issue a license key, you will need the serial number (2) of the PW4001 to which the optional. Make sure to confirm that in advance.



PW4001 rear

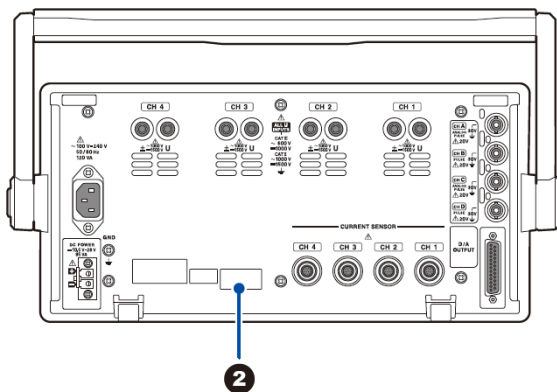

Display screen: **SYSTEM** key > **[CONFIG]**

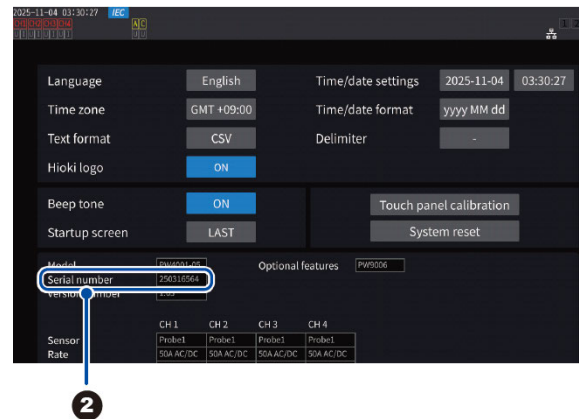

- 5 Save the license key to the media (USB flash drive or internal memory).

Do not change the filename. Changing it could prevent the PW4001 from authenticating the license key.

Authenticating the license key (performed on the PW4001)

Display screen: **SYSTEM** key > **[CONFIG]**

- 1 Upgrade to the latest version.
See "11.11 Updating the Firmware" (p.413)
- 2 Import the media into the PW4001.
- 3 Press the **FILE** key and tap on the media icon.

11.12 Adding Optional Functions

Display screen: **FILE** key



4 Select the license key.

The license key filename has the following format

“Serial number_Model name of the optional function.key”

Confirm that the serial number in the filename matches that of the PW4001 before proceeding to the next step.

5 Tap [Verify license].

Display screen: **SYSTEM** key > [CONFIG]

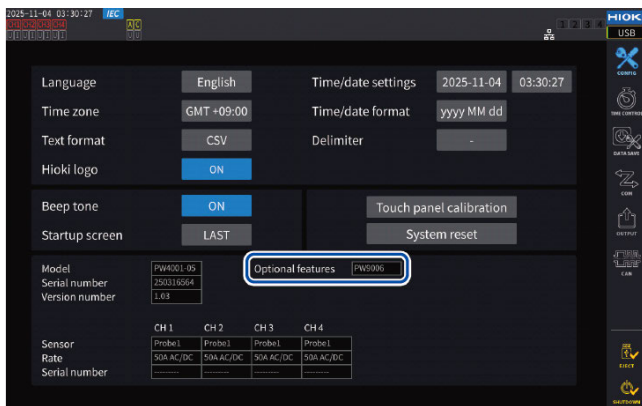

If successful, a message stating that authentication is complete will appear and the model name of the optional function can be viewed via the **SYSTEM** key > [CONFIG] screen.



If an error is displayed, carefully check the serial number and the compatible products for the optional function before starting over from step **1**.

If the error message is displayed even though the serial number and compatible product match, please contact your authorized Hioki retailer or reseller.

11.13 Disposal of the Instrument (How to Remove the Lithium Battery)

This instrument uses a lithium battery as a power source for storing measurement conditions. When disposing of the instrument, remove the lithium battery and dispose of the battery in accordance with local regulations. Dispose of all optional accessories in accordance with applicable instructions.

WARNING

-  **Do not short-circuit the battery.**
- Do not charge the Battery Pack.**
- Do not disassemble the Battery Pack.**
- Do not incinerate or heat it.**
Doing so can cause the battery to explode, resulting in bodily injury.
-  **Before removing the lithium battery, turn off the instrument and remove the power cord and the measurement cables from the object under measurement.**
Failure to do so could cause the operator to experience an electric shock.
- Store the removed batteries out of reach of young children.**
Failure to follow this guidance could lead to accidental ingestion of a battery by young children.

CALIFORNIA, USA ONLY

Perchlorate Material - special handling may apply.

Visit <https://dtsc.ca.gov/perchlorate/>

Tools to be prepared

- Phillips screwdriver (No. 2)
- Tweezers

- 1** Turn off the instrument.
- 2** Unplug current sensors, voltage cords, the power cord, and any other cords or cables.
- 3** Remove the six screws securing the rear cover using the Phillips screwdriver.

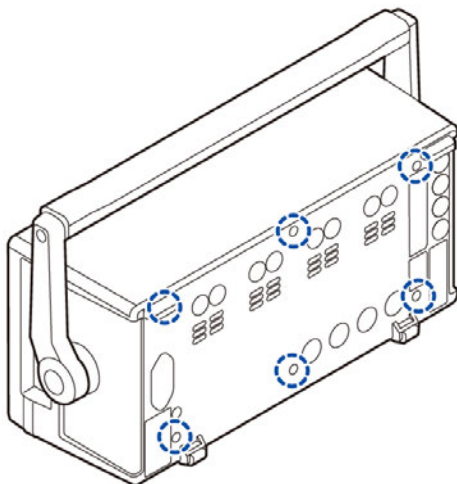

11.13 Disposal of the Instrument (How to Remove the Lithium Battery)

- 4** Slide back the rear cover to remove it.
- 5** Remove the six screws securing the front panel using the Phillips screwdriver.
- 6** Slide forward the front panel to remove it.

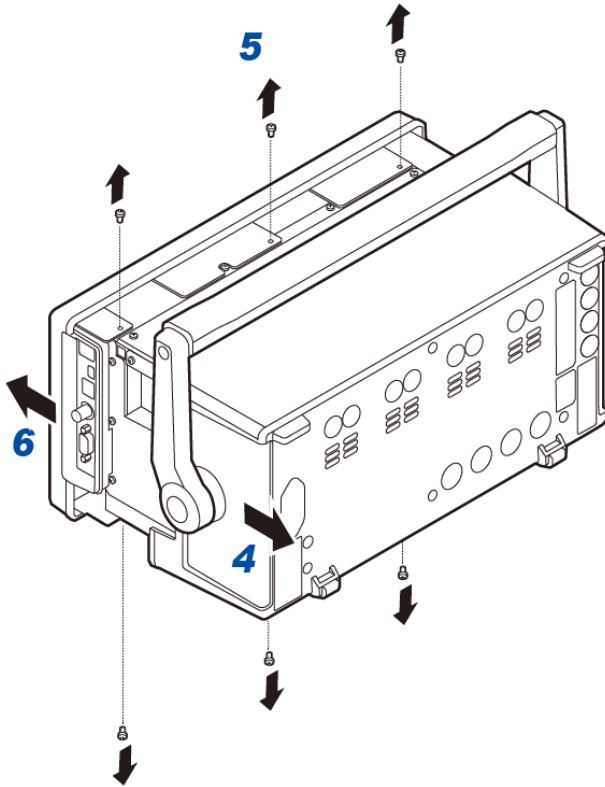

- 7** Insert the tweezers between the battery holder on the internal printed circuit board and the battery and lift up on the battery to remove it.

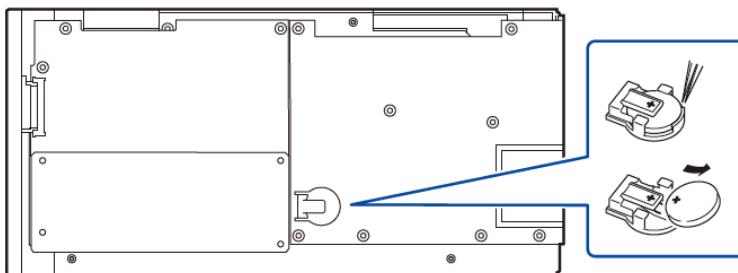

11.14 Open-Source Software

This product includes the GNU General Public License (GPL), the GNU Lesser General Public License, and other licensed software. Customers who have purchased this product have the right to obtain, modify or redistribute the source code of the software in accordance with these licenses.

For more information, visit the following website.

<https://www.hioki.com/global/support/oss>

Please do not inquire about the contents of the source code.

Index

#	
1P2W	67
1P3W	67
3P3W2M	67
3P3W3M	67
3P4W	67
3V3A	67
A	
Aliasing	153
Analog output	89, 245
A-phase pulses	142
Arbitration speed	258, 270
Auto trigger	156
Auto-ranging	31, 86
Auto-save	212
Average	44, 168
Averaging count	169
Averaging mode	169
B	
Bar graph	45
Beep tone	189
BIN format	206
BNC synchronization	239
Boot-key reset	193
B-phase pulses	142
By polarity	103
C	
CAN database	259
CAN output function	257
Carrier frequency	70
Center Frq.	135
Channel detailed display area	103
Channel indicators	31
Combinatorial accuracy	405
Comment entry	221
Communication Command Instruction Manual	7
Configuring the motor input settings	34, 123
Zero adjustment	131
Connection examples of motor analysis	127
CSV	189, 206
CSV format	206
CT	43, 97
Current input	55
Current sensors	
Auto-recognition function	67
Typical values of phase characteristics	69
Cursor	160
Cursor measurement	160
D	
Data update interval	43, 89
DBC file	257, 262
DC mode	102
Default gateway	290
Degaussing	74
Delta conversion	43, 175
Delta-Y conversion	175
Dimensions	406
Display icon	37
Displayable range	82
Displaying Waveforms	149
Disposal	419
DMAG	74
E	
Effective measurement range	82
Efficiency calculation	46, 117
Electrical angle	139
Error messages	398
Error value	264
Event (trigger detection method)	157
EXP	169
Extension	210, 212
External control terminal	255
External input	34
External signals	100, 254
External view	406
F	
Factory Default Settings	195
File	204
Firmware	
Update	413
Flicker	144
fnv value	106
Folder	205
Frequency measurement	94
FTP server function	296
Fundamental frequency	70
Fundamental wave component	106
G	
Graph display	45
Grouping	114

H

Harmonic group	113
Harmonic sub-group	113
Harmonics	45, 106
High-pass filter	95
Hold function	32
HTTP server	292

I

IEC	72
IEC harmonics/flicker measurement	144
IEC measurement mode	72, 106
Individual Input	125
Inlet	60
Input impedance	242
Integration	99
Integration mode	102
Intermediate harmonic	113
Internal memory	200
Inter-order harmonic	114
IP address	290

K

Key lock	31
Keyboard window	39

L

LAN interface	288
Level (trigger detection method)	157
List display	45
Loss	122
Lower measurement frequency limit	94
Low-pass filter	93, 133
LPF	43, 93, 133

M

MANUAL	159
Manual integration	104
Manual ranging	86
Manual save	210
MEAN	96
Measurement mode	72
Measurement screen	37
Measuring efficiency and loss	116
Auto	119
Fixed	117
Mechanical angle	136
Modbus specifications	315
Modbus/TCP	315
Motor power	130
MOV	169

N

Numeric keypad window	39
-----------------------------	----

O

Output impedance	242
Output range	245
Output rates	248
Over value	264

P

Peak hold function	32
Peak-to-peak compression	153
PHASE ADJ	139
Phase compensation	68
Phase Shift	69
Phase zero adjustment	139
PNF	133
Power calculation method	179
Power supply inlet	35
Pre-trigger	156
Pulse signal measurement	125
Pulse-noise filter	133

R

Rackmount fittings	407
Real time control	165
Real time control integration	105
Record length (Length)	152
Recording Waveforms	159
Rectification method	96
REMOTE/LOCAL	31
Repair	395
Response speed	169
Rotary encoder	136
Rotary knob	32
Rotation direction	142
RPM	130

S

Sampling speed (Freq.)	152
Scaling	43, 97
Screenshot	199, 220
Self-test	64
Settings data	223
Simple settings	70
SINGLE	159
Slip	130, 133
Special combinatorial accuracy	384
SSV	189, 206
Status data	234
Subnet mask	290
Synchronization source	43, 91
Synchronization-unlocked condition	92

Synchronous Measurement	239	Z-phase reference	139, 143
System reset	193		
System Settings	189		

T

Terminal resistance	258
Time axis setting	152
Timer control	165
Timer integration	104
Torque	130
Torque meter correction function	137
Trend	185
Trigger	156
Trigger level	157
Trigger slope	157
Trigger source	157
Typical values of phase characteristics	69

U

UDF	180
Upper measurement frequency limit	94
USB flash drive	41, 201
User-defined formula	180

V

Vector diagram display	45, 111
Virtual neutral point	175
Voltage input	54
Voltage input terminals	34
Voltage signal measurement	125
VT	43, 97

W

Warning messages	399
Waveform data	
Saving	218
WideBand	72
Wideband measurement mode	72, 106
Window wave number	114

Y

Y-delta conversion	177
--------------------------	-----

Z

Z phase	139
ZC HPF	95
ZCF	157
Zero adjustment	32, 74
Zero position	151
Zero suppress	88
Zero-cross	91
Zero-cross filter	157
ZOOM	162
Zoom function	162

HIOKI
www.hioki.com/



**All regional
contact
information**

HIOKI E.E. CORPORATION

81 Koizumi, Ueda, Nagano 386-1192 Japan

2402 EN

Edited and published by HIOKI E.E. CORPORATION

Printed in Japan

- Contents subject to change without notice.
- This document contains copyrighted content.
- It is prohibited to copy, reproduce, or modify the content of this document without permission.
- Company names, product names, etc. mentioned in this document are trademarks or registered trademarks of their respective companies.

Europe only

- EU declaration of conformity can be downloaded from our website.
- Contact in Europe: HIOKI EUROPE GmbH
Helfmann-Park 2, 65760 Eschborn, Germany hioki@hioki.eu