

# IM3523

Instruction Manual

# LCR METER



Be sure to read this manual before using the instrument.

▶ p.3



When using the instrument for the first time

Names and Functions of Parts ▶ p.10

Measurement Preparations ▶ p.21



Troubleshooting

Maintenance and Service ▶ p.215

Error display ▶ p.222





# Contents

Introduction.....	1	4.2	Setting Basic Settings of Measurement Conditions .....	31
Verifying Package Contents .....	1	4.2.1	Setting Display Parameters .....	31
Safety Information .....	3	4.2.2	Setting the Measurement frequency .....	33
Operating Precautions.....	5	4.2.3	Setting the Measurement signal level .....	37
<hr/>				
<b>Chapter 1 Overview</b>	<b>9</b>	4.2.4	Limiting the Voltage or Current Applied to the Sample (Limit Values) .....	41
1.1 Product Overview and Features .....	9	4.2.5	Setting the Measurement Range .....	43
1.2 Names and Functions of Parts .....	10	■	Setting AUTO Ranging .....	44
1.3 Screen Organization and Operation ..	12	■	AUTO range limit function .....	44
1.3.1 Initial Screen .....	12	■	Setting HOLD Ranging .....	45
1.3.2 Selecting the Measurement Mode .....	13	■	JUDGE SYNC setting .....	48
1.3.3 LCR Mode .....	14	4.2.6	Measuring at User-specified Timing (Trigger Measurement) .....	50
1.3.4 Continuous Measurement Mode .....	17	4.2.7	Setting Measurement Conditions for Individual Ranges .....	51
1.3.5 System Settings Screen .....	18	■	List screen layout .....	51
1.3.6 Comparator/BIN Settings Screen .....	19	■	Selecting range settings to change .....	52
1.3.7 Panel Load screen .....	19	■	Setting the Measurement speed .....	53
1.3.8 Compensation Settings Screen .....	19	■	Displaying Average Values (Average set) .....	54
1.3.9 Information Screen .....	20	■	Setting a delay before measurement data is acquired (trigger delay) .....	56
<hr/>				
<b>Chapter 2 Measurement Preparations</b>	<b>21</b>	■	Applying the signal to the sample during measurement only (Trigger Synchronous Output Function) ...	57
2.1 Preparation Flowchart .....	21	4.3	Setting DC Resistance Measurement .....	61
2.2 Pre-Operation Inspection .....	22	4.3.1	Setting the Measurement Range .....	62
2.3 Connecting the Power Cord .....	23	■	Setting AUTO Ranging .....	63
2.4 Connect measurement cables, optional Hioki probes or test fixture .....	24	■	AUTO range limit function .....	63
2.5 Connecting an Interface .....	25	■	Setting HOLD Ranging .....	64
2.6 Turning the Power On and Off .....	26	■	JUDGE SYNC setting .....	66
<hr/>				
<b>Chapter 3 Measurement Example</b>	<b>27</b>	4.3.2	Setting a Delay Time for DC Measurement (DC Delay) .....	67
<hr/>				
<b>Chapter 4 LCR Function</b>	<b>29</b>	4.3.3	Setting a Delay Time for Offset Measurement (Adjustment Delay) .....	69
4.1 About LCR function .....	29	4.3.4	Setting the Line Frequency .....	70
		4.3.5	Setting Measurement Conditions for Individual Ranges .....	71
		■	List screen layout .....	71
		■	Selecting the range setting you wish to change .....	72
		■	Setting the measurement speed .....	73



6.3	Adjusting Values Based on Reference Values(Load Compensation) .....	145
6.4	Compensating Measurement Cable Errors(Cable Length Compensation) .....	157
6.5	Converting Values (Scaling) .....	158

---

## Chapter 7 Saving and Reading Panel Information **161**

7.1	Saving Measurement Conditions (Panel Save Function) .....	162
7.2	Reading Measurement Conditions (Panel Load Function) .....	165
7.3	Changing a Panel Name .....	167
7.4	Deleting a Panel .....	169

---

## Chapter 8 Setting the SYSTEM **171**

8.1	Setting the Interface .....	171
8.2	Checking the Version of the Instrument .....	172
8.3	Self Checks (Self Diagnosis) .....	173

---

## Chapter 9 External Control **177**

9.1	External Input/Output Connector and Signals .....	177
■	Connector Type and Signal pin assignments .....	178
■	Signal Descriptions .....	182
9.2	Timing Chart .....	184
9.2.1	LCR Measurement .....	184
9.2.2	Continuous Measurement .....	187
9.3	Internal Circuitry .....	188
■	Electrical Specifications .....	189
■	Connection Examples .....	190
9.4	External I/O Settings .....	191
■	Setting Delay Time from Output of Comparator and BIN Judgment Results until Output of EOM (LOW) .....	191
■	Setting Reset of Judgment Results .....	191
■	Enabling Trigger Input for during Measurement .....	191
■	Setting Valid Edge of Trigger Input .....	191

9.5	External Control Q&A .....	192
9.6	Measurement Using a Computer .....	193

---

## Chapter 10 Printing **195**

10.1	Connecting the Printer .....	195
■	Connecting the Printer to the Instrument .....	196
10.2	Instrument and Printer Settings .....	197
■	Make Instrument Settings .....	197
10.3	Printing .....	198

---

## Chapter 11 Specifications **201**

11.1	General Specifications .....	201
11.2	Measurement Range and Accuracy .....	206
■	Example calculation .....	210
11.3	About Measurement Times and Measurement Speed .....	213

---

## Chapter 12 Maintenance and Service **215**

12.1	Inspection, Repair and Cleaning .....	215
12.2	Troubleshooting .....	217
12.3	Error display .....	222
12.4	Disposing of the Instrument .....	224

---

## Appendix **A1**

Appendix1	Measurement Parameters and Calculation formula .....	A 1
Appendix2	Measurement of High Impedance Components.....	A 3
Appendix3	Measuring In-circuit Elements..	A 4
Appendix4	Countermeasures Against Incorporation of External Noise	A 5
Appendix4.1	Countermeasures Against Incorporation of Noise from the Power Line .....	A 5
Appendix4.2	Countermeasures Against Noise from the measurement Cables .....	A 6

4

5

6

7

8

9

10

11

12

Appendix

Index

## Contents

---

---

Appendix5 Supplying DC Bias .....	A 7
Appendix5.1How to Supply a DC Bias Voltage .....	A 7
Appendix5.2How to Supply a DC Bias Current .....	A 8
Appendix6 The Residual Charge Protection Function .....	A 9
Appendix7 Series Equivalent Circuit Mode and Parallel Equivalent Circuit Mode .....	A 10
Appendix8 Open Circuit Compensation and Short Circuit Compensation ...	A 11
Appendix9 Rack Mounting .....	A 13
Appendix10Dimensional Diagram .....	A 15
Appendix11Initial Settings Table .....	A 16
Appendix12Device Compliance Statement .....	A 20

## Introduction

Thank you for purchasing the HIOKI Model IM3523 LCR Meter. To obtain maximum performance from the instrument, please read this manual first, and keep it handy for future reference.

## Verifying Package Contents

When you receive the instrument, inspect it carefully to ensure that no damage occurred during shipping. In particular, check the accessories, panel switches, and connectors. If damage is evident, or if it fails to operate according to the specifications, contact your dealer or Hioki representative.

### Confirm that these contents are provided.

IM3523 LCR Meter ..... 1

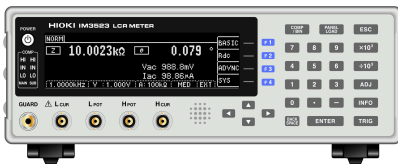

Power Cord (2-line + ground)..... 1

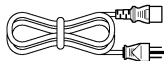

(p. 23)

Instruction Manual(This document)  
..... 1



LCR Application Disk ..... 1  
(Communication Instruction Manual (PDF-format), explanation of communications commands, USB driver, sample application)



The latest version can be downloaded from our web site.

### **NOTE**

- Probes, fixture are not supplied with the unit as standard equipment. You should order them separately, according to requirements.
- The instrument ships from the factory configured as described in "Appendix11 Initial Settings Table"(p. A16).

### Precautions when transporting the instrument

Use the original packing materials when transporting the instrument, if possible.

See "Transporting the instrument" (p. 216)

## Verifying Package Contents

### Options

The following options are available for the instrument. Contact your authorized Hioki distributor or reseller when ordering. The options are subject to change. Visit our website for updated information.

#### L2000 4-terminal Probe

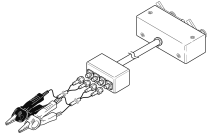

▼ Alligator-clip-type measurement probes. These general-purpose dual-electrode clips fit a wide range of conductor thicknesses.

Measurable range: DC to 8 MHz  
 Maximum voltage:  $\pm 42$  V<sub>peak</sub> (AC+DC)  
 Maximum current:  $\pm 1$  A<sub>peak</sub> (AC+DC)  
 Measurement terminal hole diameter: 0.3 to 5 mm

#### 9500-10 4-terminal Probe

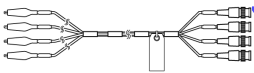

▼ Rubber-sheathed alligator clip type

Measurable range: DC to 200 kHz  
 Maximum voltage: DC $\pm 40$  V (42 V<sub>peak</sub> (Measurement signal + bias voltage))  
 Maximum current: 1 A<sub>peak</sub> (Measurement signal + bias current)  
 Measurement terminal hole diameter: 0.3 to 2 mm

#### 9261-10 Test Fixture

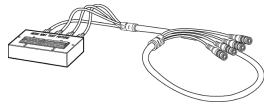

Measurable range: DC to 8 MHz  
 Maximum applied voltage: DC $\pm 40$  V  
 Measurement terminal hole diameter: 0.3 to 1.5 mm

#### 9263 SMD Test Fixture

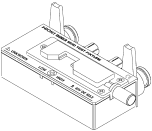

▼ This fixture is for measuring chip components. (less than 10 m $\Omega$  residual resistance after zero adjustment)

Measurable range: DC to 8 MHz  
 Maximum applied voltage: DC $\pm 40$  V  
 Test sample dimensions: Test sample width of 1 to 10 mm

#### 9268-10 DC Bias Voltage Unit

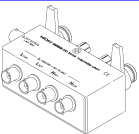

Measurable range: 40 Hz to 8 MHz  
 Maximum applied voltage: DC $\pm 40$  V

#### 9699 SMD Test Fixture

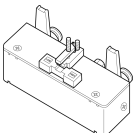

▼ This fixture is for the lower electrode.

Measurable range: DC to 120 MHz  
 Maximum applied voltage: DC $\pm 40$  V  
 Test sample dimensions: Test sample width of 1 to 4 mm  
 Test sample height of 1.5 mm or less

#### Z3000 GP-IB Interface



#### IM9100 SMD Test Fixture

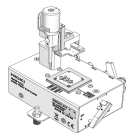

Measurable range: DC to 8 MHz  
 Maximum applied voltage:  $\pm 42$  V<sub>peak</sub> (AC+DC)  
 Maximum applied current:  $\pm 0.15$  A rms ( $\pm 0.15$  ADC)  
 Measurement test sample dimensions: 0.4 $\times$ 0.2 mm, 0.6 $\times$ 0.3 mm, 1.0 $\times$ 0.5 mm

#### Z3001 RS-232C Interface



#### IM9110 SMD Test Fixture

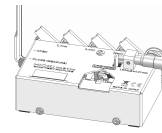

Measurable range: DC to 1 MHz  
 Maximum applied voltage:  $\pm 42$  V<sub>peak</sub> (AC+DC)  
 Maximum applied current:  $\pm 0.15$  A rms ( $\pm 0.15$  ADC)  
 Measurement test sample dimensions: 0.25  $\pm 20\%$   $\times$  0.125  $\pm 10\%$   $\times$  0.125  $\pm 10\%$  mm

#### Z3002 LAN Interface

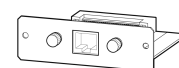

#### 9140-10 4-terminal Probe



Measurable range: DC to 200 kHz  
 Maximum voltage:  $\pm 42$  V<sub>peak</sub> (AC+DC)  
 Maximum current:  $\pm 1$  A<sub>peak</sub> (AC+DC)  
 Measurement terminal hole diameter: 0.3 to 5 mm

#### L2001 Pincher Probe

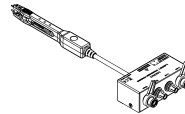

Measurable range: DC to 8 MHz  
 Maximum applied voltage:  $\pm 42$  V<sub>peak</sub> (AC+DC)  
 Maximum applied current:  $\pm 1$  A<sub>peak</sub> (AC+DC)  
 Electrode tip spacing: 0.3 to approx. 6 mm

#### 9262 Test Fixture

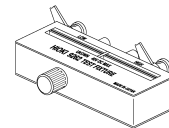

▼ This fixture is for measuring lead components. (less than 10 m $\Omega$  residual resistance after zero adjustment)

Measurable range: 42 Hz to 8 MHz  
 Maximum applied voltage: DC $\pm 40$  V  
 Test sample dimensions: Lead diameter of 0.3 to 2 mm  
 Lead pitch of 5 mm or more

#### 9677 SMD Test Fixture

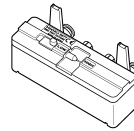

Measurable range: DC to 120 MHz  
 Maximum applied voltage: DC $\pm 40$  V  
 Test sample width of 3.5 $\pm$ 0.5 mm or less

#### 9269-10 DC Bias Current Unit

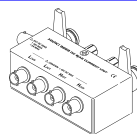

Measurable range: 40 Hz to 2 MHz  
 Maximum applied current: DC 2 A











## Safety Information

**! WARNING** This instrument is designed to comply with IEC 61010 Safety Standards, and has been thoroughly tested for safety prior to shipment. However, mishandling during use could result in injury or death, as well as damage to the instrument. Using the instrument in a way not described in this manual may negate the provided safety features.





Be certain that you understand the instructions and precautions in the manual before use. We disclaim any responsibility for accidents or injuries not resulting directly from instrument defects.

This manual contains information and warnings essential for safe operation of the instrument and for maintaining it in safe operating condition. Before using it, be sure to carefully read the following safety precautions.



## Safety Symbols

	In the manual, the  symbol indicates particularly important information that the user should read before using the instrument.
	The  symbol printed on the instrument indicates that the user should refer to a corresponding topic in the manual (marked with the  symbol) before using the relevant function.
	Indicates AC (Alternating Current).
	Indicates the ON side of the power switch.
	Indicates the OFF side of the power switch.

The following symbols in this manual indicate the relative importance of cautions and warnings.

	Indicates that incorrect operation presents a significant hazard that could result in serious injury or death to the user.
	Indicates that incorrect operation presents a significant hazard that could result in serious injury or death to the user.
	Indicates that incorrect operation presents a possibility of injury to the user or damage to the instrument.
	Indicates advisory items related to performance or correct operation of the instrument.

## Symbols for Various Standards

	WEEE marking: This symbol indicates that the electrical and electronic appliance is put on the EU market after August 13, 2005, and producers of the Member States are required to display it on the appliance under Article 11.2 of Directive 2002/96/EC (WEEE).
	This symbol indicates that the product conforms to regulations set out by the EU Directive.

### Notation

#### Symbols in this manual

	Indicates a prohibited action.
(p. )	Indicates the location of reference information.
*	Indicates that descriptive information is provided below.
[ ]	Menus, Pages, Setting items, dialogs, buttons in a dialog, and other names on the screen and the keys are indicated in brackets.
<b>Windows</b>	Unless otherwise specified, "Windows" represents Windows 95, 98, Me, Windows NT4.0, Windows 2000, Windows XP, Windows Vista or Windows 7.
<b>Dialogue</b>	Dialogue box represents a Windows dialog box.
	Indicates that digits may be entered. (p. 35)
	Indicates that values may be entered using the numeric keypad. (p. 33)
	Indicates that the same operation can be performed by pressing the ENTER key.
	The cursor key to be used is shown in black, while unused cursor keys are shown in gray. (In the example to the left, the  key is to be used.)

#### Accuracy

We define measurement tolerances in terms of f.s. (full scale), rdg. (reading) and dgt. (digit) values, with the following meanings.

<b>f.s. (maximum display value or scale length):</b>	The maximum displayable value or scale length. This is usually the name of the currently selected range.
<b>rdg.(reading or displayed value):</b>	The value currently being measured and indicated on the measuring instrument.
<b>dgt. (resolution):</b>	The smallest displayable unit on a digital measuring instrument, i.e., the input value that causes the digital display to show a "1" as the least-significant digit.

### Measurement categories

To ensure safe operation of measurement instruments, IEC 61010 establishes safety standards for various electrical environments, categorized as CAT II to CAT IV, and called measurement categories.

<b>CAT II</b>	Primary electrical circuits in equipment connected to an AC electrical outlet by a power cord (portable tools, household appliances, etc.) CAT II covers directly measuring electrical outlet receptacles.
<b>CAT III</b>	Primary electrical circuits of heavy equipment (fixed installations) connected directly to the distribution panel, and feeders from the distribution panel to outlets.
<b>CAT IV</b>	The circuit from the service drop to the service entrance, and to the power meter and primary overcurrent protection device (distribution panel).

Using a measurement instrument in an environment designated with a higher-numbered category than that for which the instrument is rated could result in a severe accident, and must be carefully avoided. Using a measurement instrument in an environment designated with a highernumbered category than that for which the instrument is rated could result in a severe accident, and must be carefully avoided.

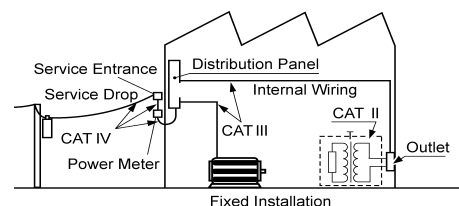

# Operating Precautions



Follow these precautions to ensure safe operation and to obtain the full benefits of the various functions.

## Preliminary Checks

Before using the instrument the first time, verify that it operates normally to ensure that no damage occurred during storage or shipping. If you find any damage, contact your dealer or Hioki representative.



**Before using the instrument, make sure that the insulation on the voltage cords is undamaged and that no bare conductors are improperly exposed. Using the instrument in such conditions could cause an electric shock, so contact your dealer or Hioki representative for replacements.**







## Instrument Installation

Operating temperature and humidity : 0 to 40°C, 20%RH to 80%RH, Indoors only (non-condensating)

Storing temperature and humidity : -10 to 55°C, 20%RH to 80%RH, Indoors only (non-condensating)

Temperature and humidity range for guaranteed accuracy : 0 to 40°C, 20%RH to 80%RH

Avoid the following locations that could cause an accident or damage to the instrument.

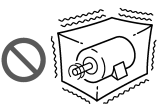
	Exposed to direct sunlight Exposed to high temperature		In the presence of corrosive or explosive gases
	Exposed to water, oil, other chemicals, or solvents Exposed to high humidity or condensation		Exposed to strong electromagnetic fields Near electromagnetic radiators
	Exposed to high levels of particulate dust		Near induction heating systems (e.g., high-frequency induction heating systems and IH cooking utensils)
	Subject to vibration		

- The instrument should be operated only with the bottom or rear side downwards.
- The instrument must not be placed on an unstable table or tilted surface.
- Vents must not be obstructed.

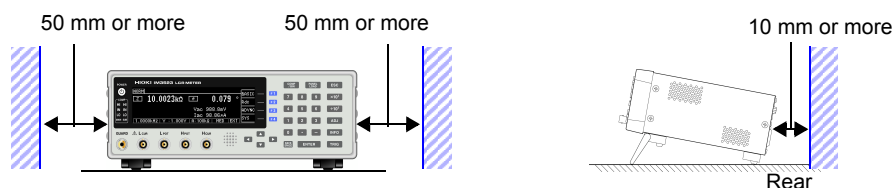

The instrument can be used with the stand.(p. 11)  
It can also be rack-mounted.(p.A13)

**Shipping precautions**

Hioki disclaims responsibility for any direct or indirect damages that may occur when this instrument has been combined with other devices by a systems integrator prior to sale, or when it is resold.

**Handling the Instrument**** DANGER**

- To avoid electric shock, do not remove the instrument's case. The internal components of the instrument carry high voltages and may become very hot during operation.
- Do not allow the instrument to get wet, and do not take measurements with wet hands. This may cause an electric shock.

** CAUTION**

- If the instrument exhibits abnormal operation or display during use, review the information in "Troubleshooting" (p. 217) and "Error display" (p. 222) before contacting your dealer or Hioki representative.
- Do not connect charged capacitors to measurement terminals or input voltages or currents from an external source. Doing so may damage the instrument.
- This instrument is not designed to be entirely water- or dust-proof. Do not use it in an especially dusty environment, nor where it might be splashed with liquid. This may cause damage.
- To avoid damage to the instrument, protect it from physical shock when transporting and handling. Be especially careful to avoid physical shock from dropping.
- Do not apply heavy downward pressure with the stand extended. The stand could be damaged.
- After use, always turn OFF the power.

**NOTE**

This instrument may cause interference if used in residential areas. Such use must be avoided unless the user takes special measures to reduce electromagnetic emissions to prevent interference to the reception of radio and television broadcasts.

**Before Turning Power On**** WARNING**

- Before turning the instrument on, make sure the supply voltage matches that indicated on its power connector. Connection to an improper supply voltage may damage the instrument and present an electrical hazard.
- Be careful to avoid connecting the supply voltage improperly. Doing so may damage the instrument's internal circuitry.
- To avoid electrical accidents and to maintain the safety specifications of this instrument, connect the power cord only to a 3-contact (two-conductor + ground) outlet.
- To avoid shock and short circuits, turn off all power before connecting probes.

## About Handling of Cords and Fixtures

### **CAUTION**

- For safety reasons, disconnect the power cord when the instrument is not used.
- To avoid damaging the power cord, grasp the plug, not the cord, when unplugging it from the power outlet.
- Do not apply a voltage to the measurement terminals. Doing so may damage the instrument.
- When disconnecting the BNC connector, be sure to release the lock before pulling off the connector. Forcibly pulling the connector without releasing the lock, or pulling on the cable, can damage the connector.
- To avoid breaking the cables or probes, do not bend or pull them.
- Avoid stepping on or pinching cables, which could damage the cable insulation.
- Keep the cables well away from heat sources, as bare conductors could be exposed if the insulation melts.
- Keep in mind that, in some cases, conductors to be measured may be hot.
- To avoid electric shock, do not exceed the lower of the ratings shown on the instrument and connection cords.

### **NOTE**

- Use only the specified connection cables. Using a non-specified cable may result in incorrect measurements due to poor connection or other reasons.
- Before using a fixture or the like, read the instruction manual supplied with the product to be used.

## Before Connecting EXT I/O

### **WARNING**

To avoid electric shock or damage to the equipment, always observe the following precautions when connecting to the EXT I/O connector.

- Always turn off the power to the instrument and to any devices to be connected before making connections.
- Be careful to avoid exceeding the ratings of external terminals.(p. 189)
- During operation, a wire becoming dislocated and contacting another conductive object can be serious hazard. Make sure that connections are secure and use screws to secure the external connectors.
- Properly insulate any devices and mechanisms to be connected to the EXT I/O connector.
- The ISO\_5 V pin of the EXT I/O connector is a 5 V power output. Do not apply external power to this pin.

**About interfaces (option)****Before switching interfaces**

- To avoid electric shock when adding or switching interfaces, turn off the instrument and disconnect all connection and power cords before installing or removing interfaces.
- Failure to secure the interface in place with screws may cause equipment failure or otherwise prevent the instrument from performing in a manner that satisfies its specifications.

**When not using the interface (option)**

- To avoid electric shock, do not use the instrument with the interface removed. When removing the interface, be sure to attach the blank panel in its place.

**Handling the LCR Application Disk**

- Always hold the disc by the edges, so as not to make fingerprints on the disc or scratch the printing.
- Never touch the recorded side of the disc. Do not place the disc directly on anything hard.
- Do not wet the disc with volatile alcohol or water, as there is a possibility of the label printing disappearing.
- To write on the disc label surface, use a spirit-based felt pen. Do not use a ball-point pen or hard-tipped pen, because there is a danger of scratching the surface and corrupting the data. Do not use adhesive labels.
- Do not expose the disc directly to the sun's rays, or keep it in conditions of high temperature or humidity, as there is a danger of warping, with consequent loss of data.
- To remove dirt, dust, or fingerprints from the disc, wipe with a dry cloth, or use a CD cleaner. Always wipe from the inside to the outside, and do not wipe with circular movements. Never use abrasives or solvent cleaners.
- Hioki shall not be held liable for any problems with a computer system that arises from the use of this LCR Application Disk, or for any problem related to the purchase of a Hioki product.

# Overview

# Chapter 1

1

Chapter 1 Overview

## 1.1 Product Overview and Features

The HIOKI IM3523 LCR Meter is an impedance measuring instrument that features high-speed, high-precision operation.

With measurement frequencies of 40 Hz to 200 kHz and measurement signal levels of 5 mV to 5 V, the instrument allows you to configure a broad range of measurement conditions. Additionally, the ability to perform tests using different measurement conditions with a single instrument while changing setup profiles easily makes the IM3523 well suited for use on production lines.

### Wide range of measurement conditions(p.31)

Capable of measurement under a wide range of measurement conditions: measurement frequencies from 1 mHz to 200 kHz and measurement signal levels from 5 mV to 5 V.

### Various interfaces supported

Supports the optimal external I/O (handler interfaces) for production lines: USB, GP-IB, RS-232C, and LAN. (GP-IB, RS-232C, and LAN interfaces are optional.)

### Comparator function(p.76)

Capable of making HI/IN/LO pass/fail judgments based on measurement values for two parameters.

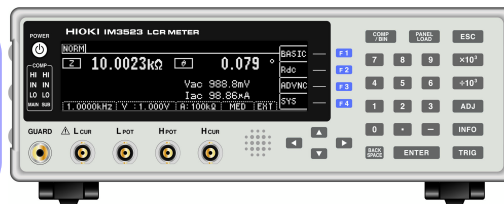

### Capable of high-speed measurement

High-speed measurement is possible. The IM3532 and IM3533-01 can perform measurements at speeds of up to 2 ms (typical values).

### BIN function(p.83)

Capable of easily ranking up to 10 samples based on measurement values.

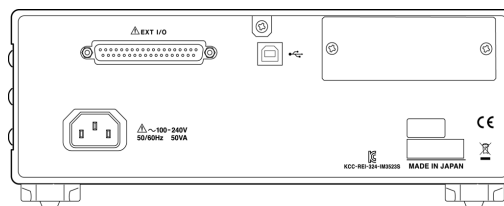

### Simple production line setup changes

Automatically sets the optimal range according to comparator or BIN judgment standards. Because the IM3523 also lets you set measurement conditions separately for each range, it is possible to automatically set the optimal measurement conditions in response to range changes.

### Continuous measurement function(p.119)

Capable of performing continuous measurement using previously stored measurement conditions. This function makes it possible to generate pass/fail judgments using different sets of measurement conditions. (For example, the instrument can perform C-D measurement at 120 Hz followed by Rs measurement at 100 kHz.)

# 1.2 Names and Functions of Parts

## Front

**Power Switch(p.26)**



- Unlit : power off (when no power supplied)
- Red light : power off (while power is supplied)
- Green light : power on

**Display Screen(p.12)**  
 Monochrome graphical LCD  
 Displays the Measurement screen, Basic Settings screen, and Advanced Settings screen.



**COMP/BIN Key(p.75)**  
 When the comparator/BIN function is enabled, displays the Comparator/BIN Settings screen.

**Panel Load Key(p.165)**  
 Loads measurement conditions saved with the panel save function.

**Entering numerical values(p.12)**

  Enter a numerical value. (we call these the “tenkeys”)

 Adds a minus sign to the value.

  Switches units.

 Deletes the value in the selected field.

 Accepts the value and settings.

 Cancels the measurement condition settings for each range and the comparator/BIN settings, and then returns to the screen that was displayed before you began configuring settings.

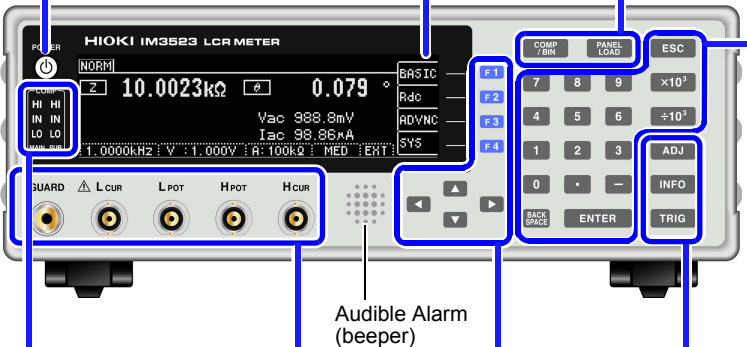



**COMP indicator LEDs**  
 Displays the measurement value judgment results for the main and sub parameters.

Comparator measurement  
 See (p.76)  
 BIN measurement  
 See (p.83)

**Measurement Terminals**  
 Connect measurement cables or a fixture.  
 (H<sub>CUR</sub> jack, H<sub>POT</sub> jack, L<sub>POT</sub> jack, L<sub>CUR</sub> jack, GUARD jack)



**ADJ Key(p.125)**  
 Lets you configure and use compensation functions and scaling.

**INFO Key(p.20)**  
 Lets you check previously configured measurement conditions.

**TRIG Key(p.50)**  
 Performs trigger measurement under the conditions for which the external trigger has been configured.

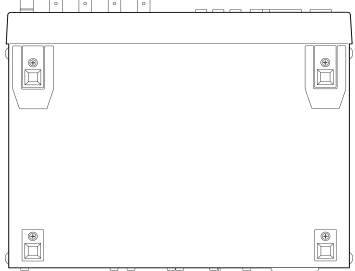
## Panel



**F keys**  
  Selects the corresponding item on the right side of the display.

**Cursor keys**  
 Selects items on the screen.

**This instrument can be rack mounted.**  
 See "Appendix9 Rack Mounting"(p. A13)

**Parts removed from this instrument should be stored in a safe place to enable future reuse.**



Rear

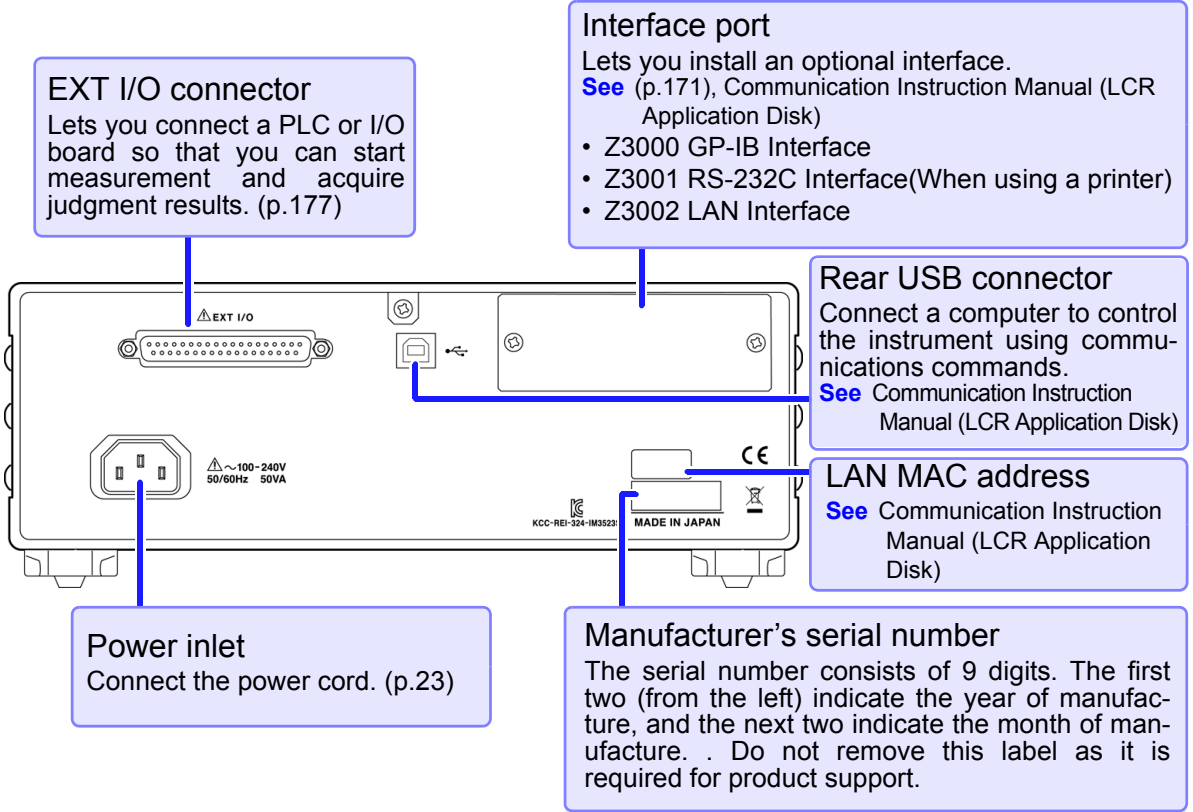

Left

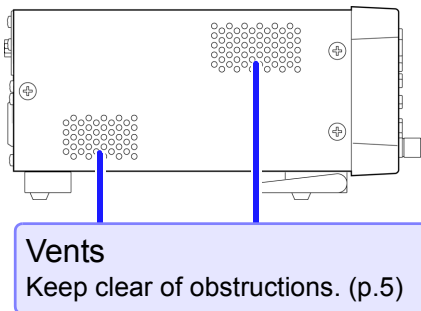

**CAUTION**  
Do not apply heavy downward pressure with the stand extended. The stand could be damaged.

Right

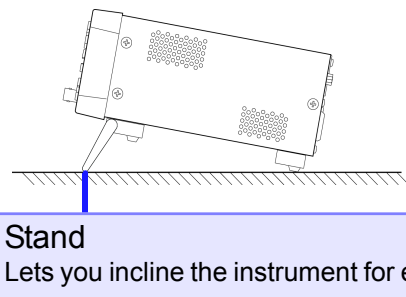

**When using the stand**  
Extend the stand until it clicks into place. Make sure to extend both legs of the stand.

**Collapsing the stand**  
Fold in the stand until it clicks into place.

### 1.3 Screen Organization and Operation

The instrument has two general display screen types: Measurement and Settings.  
 Refer to "12.3 Error display" (p. 222) for error displays.

The screen examples in this guide appear reversed (black on white) for best visibility on the printed page. However, the instrument screens can actually be displayed only as white characters on black background.

#### 1.3.1 Initial Screen

The initial screen, which is the first screen displayed when you turn on the instrument, allows you to perform measurement while checking measurement conditions. When the instrument is turned back on, the display will reflect the measurement mode that was in use when the power was turned off.

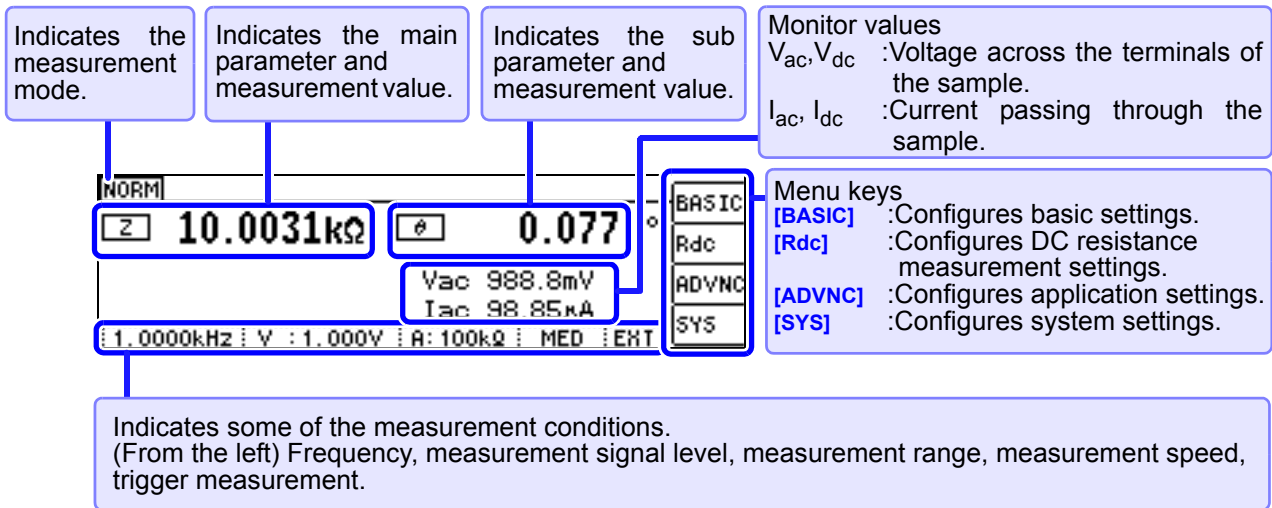

#### Key lock screen

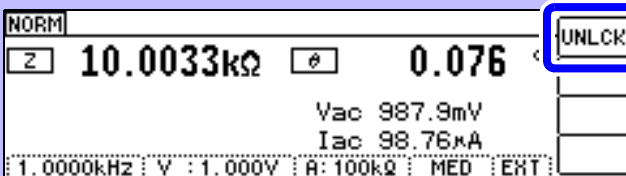

`F1`

The Pass Code Entry screen will be displayed.  
 See "Canceling key lock mode" (p. 117)

## 1.3.2 Selecting the Measurement Mode

This section describes how to select the measurement mode.

- 1 Open the Advanced Settings screen.

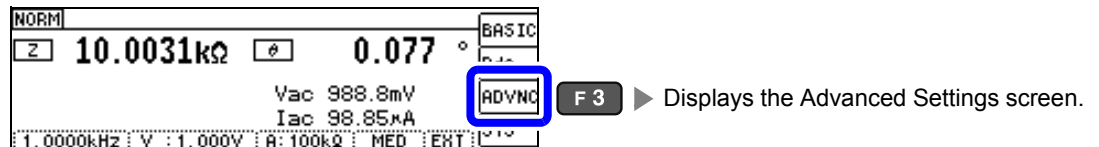

- 2 Select the [MODE].

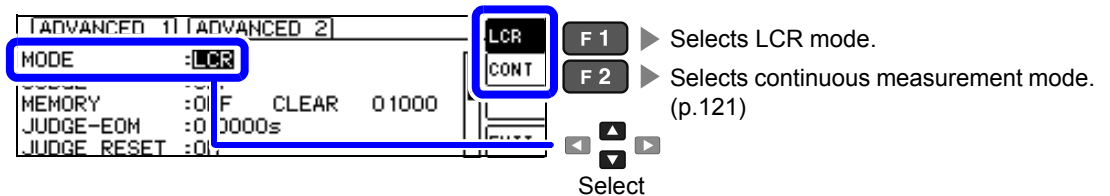

- 3 Set the mode.

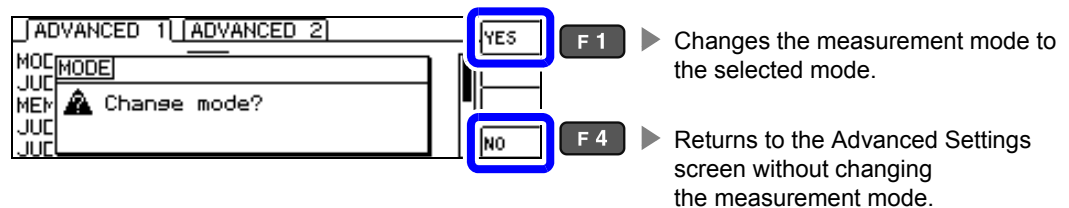

**NOTE** After changing the measurement mode, check all settings (including compensation) before performing measurement.

### 1.3.3 LCR Mode

#### Screen Organization

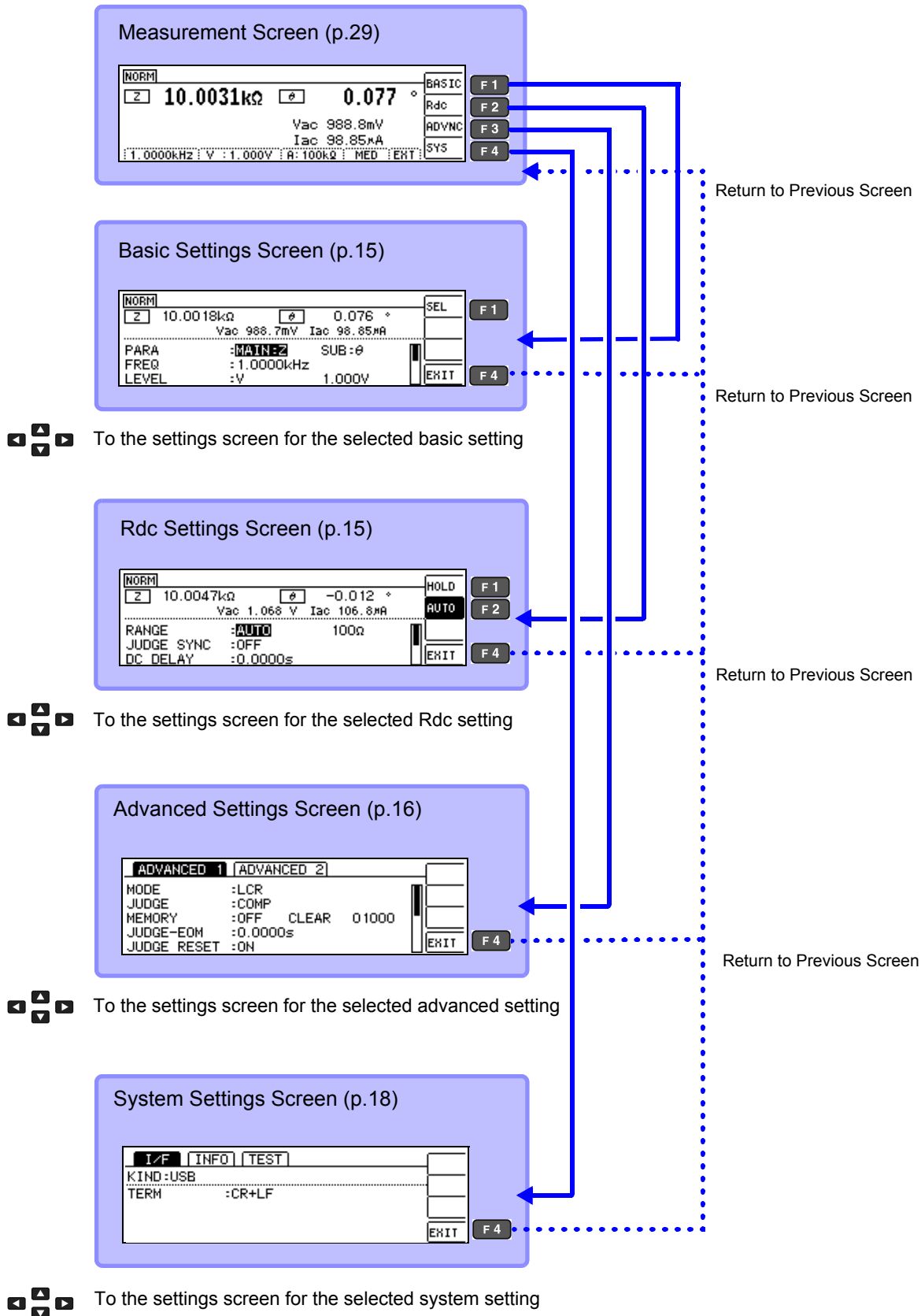

Basic Settings Screen

Basic Settings Screen

This screen allows you to configure basic settings for the measurement conditions.

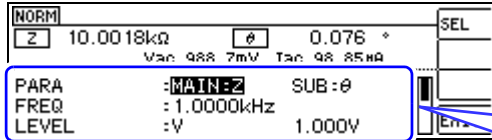

Settings

<b>PARA</b>	Measurement parameter setting (p.31)
<b>FREQ</b>	Measurement frequency setting (p.33)
<b>LEVEL</b>	Measurement signal level setting (p.37)
<b>LIMIT</b>	Voltage and current limit settings (p.41)
<b>RANGE</b>	Measurement range setting (p.43)
<b>JUDGE SYNC</b>	Judgment synchronization setting (p.48)
<b>TRIG</b>	Trigger setting (p.50)
<b>LIST</b>	Setting of measurement conditions for the respective ranges (p.51)

LIST Settings screen

This screen is displayed when you select [LIST] on the Basic Settings screen. It allows you to configure measurement conditions for each range.

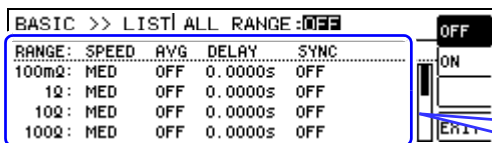

Settings

<b>SPEED</b>	Measurement speed setting (p.53)
<b>AVG</b>	Average setting (p.54)
<b>DELAY</b>	Trigger delay setting (p.56)
<b>SYNC</b>	Trigger synchronization output setting (p.57)

Rdc (DC resistance measurement) Settings screen

This screen allows you to configure measurement conditions for DC resistance measurement.

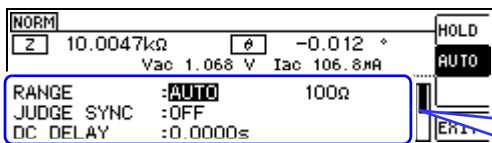

Settings

<b>RANGE</b>	Measurement range setting (p.62)
<b>JUDGE SYNC</b>	Judgment synchronization setting (p.66)
<b>DC DELAY</b>	DC delay setting (p.67)
<b>ADJ DELAY</b>	Adjustment delay setting (p.69)
<b>LINE FREQ</b>	Line frequency setting (p.70)
<b>LIST</b>	Setting of measurement conditions for the respective ranges (p.71)

LIST Settings screen

This screen is displayed when you select [LIST] on the Rdc Settings screen. It allows you to configure measurement conditions for each range.

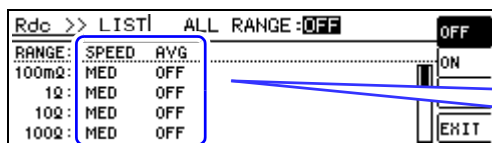

Settings

<b>SPEED</b>	Measurement speed setting (p.73)
<b>AVG</b>	Average setting (p.74)

### Advanced Settings Screen

#### Advanced 1 Settings Screen

This screen is used to configure LCR mode application settings.

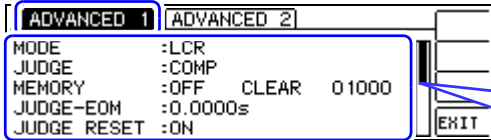

#### Settings

<b>MODE</b>	Measurement mode setting (p.13)
<b>JUDGE</b>	Measurement result judgment setting (p.75)
<b>MEMORY</b>	Save settings of measurement results (p.97)
<b>JUDGE-EOM</b>	JUDGE-EOM delay time setting (p.100)
<b>JUDGE RESET</b>	JUDGE-EOM reset setting (p.100)
<b>TRIG ENABLE</b>	IO trigger setting (p.101)
<b>TRIG EDGE</b>	IO trigger valid edge setting (p.101)
<b>EOM MODE</b>	EOM output method setting (p.102)
<b>EOM-ON-TIME</b>	EOM output time setting (p.102)
<b>CONTACT</b>	Contact check function setting (p.103)
<b>Hi Z</b>	Hi-Z reject function setting (p.105)

#### Advanced 2 Settings Screen

This screen is used to configure LCR mode application settings.

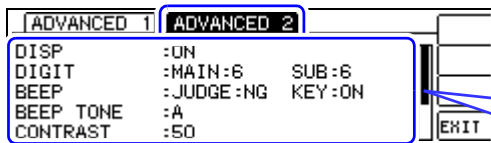

#### Settings

<b>DISP</b>	LCD settings (p.107)
<b>DIGIT</b>	Number of display digits setting (p.108)
<b>BEEP</b>	Beep enable/disable setting (p.110)
<b>BEEP TONE</b>	Beep tone setting (p.112)
<b>CONTRAST</b>	Screen contrast setting (p.113)
<b>KEYLOCK</b>	Key-lock setting (p.114)
<b>PANEL SAVE</b>	Panel save (p.162)
<b>RESET</b>	System reset (p.118)

#### Panel Save Screen

This screen is used to configure continuous measurement mode application settings.

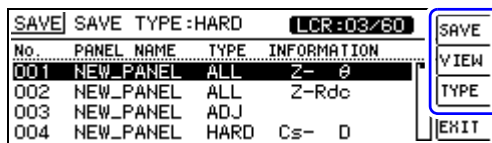

#### Settings

<b>SAVE</b>	Panel save (p.163)
<b>VIEW</b>	Panel information display (p.164)
<b>TYPE</b>	Panel save type setting (p.162)

### 1.3.4 Continuous Measurement Mode

#### Screen Organization

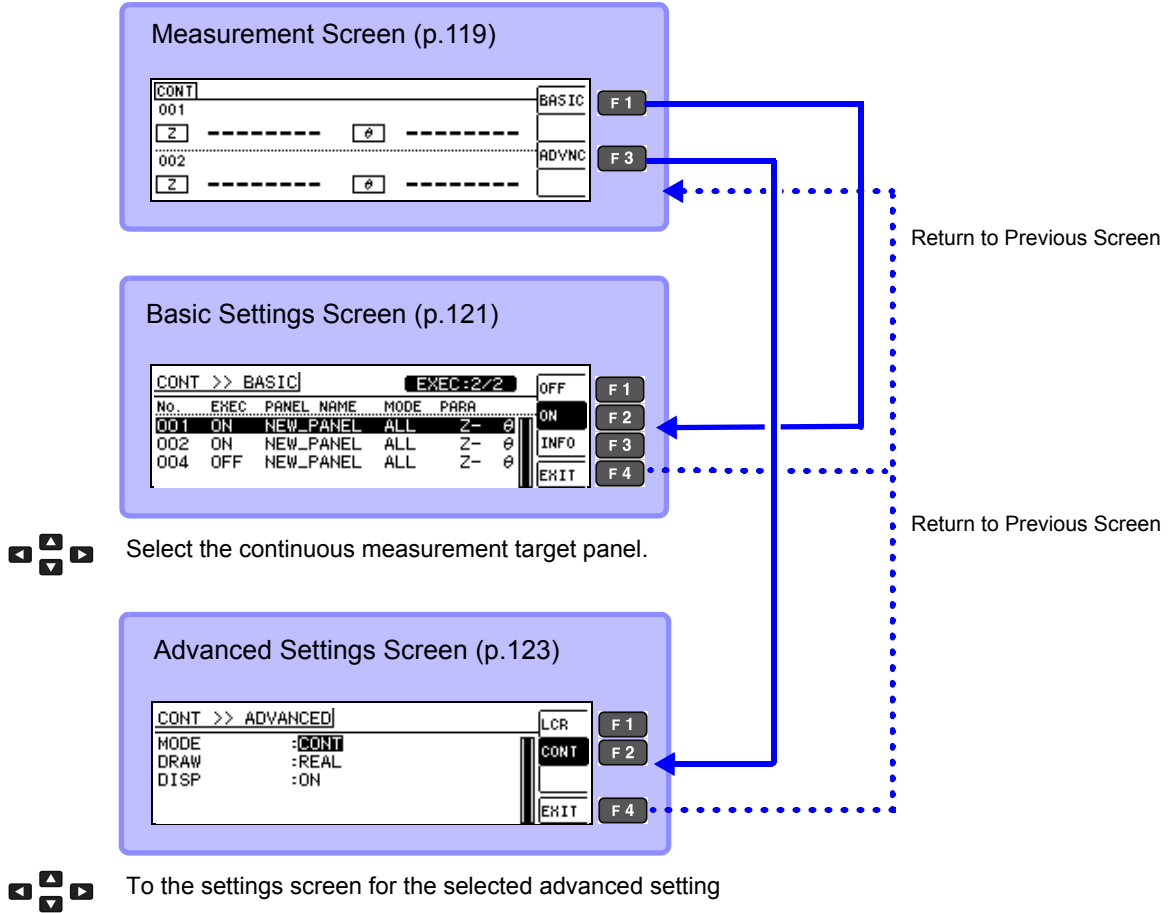

#### Basic Settings Screen

This screen allows you to check continuous measurement settings and saved panel information. (p.121)

CONT >> BASIC		EXEC:2/2	OFF
No.	EXEC	PANEL NAME	MODE PARA
001	ON	NEW_PANEL	ALL Z- 0
002	ON	NEW_PANEL	ALL Z- 0
004	OFF	NEW_PANEL	ALL Z- 0

Settings

OFF	Turns off continuous measurement
ON	Turns on continuous measurement
INFO	Panel information display

#### Advanced Settings Screen

This screen is used to configure continuous measurement mode application settings. (p.123)

CONT >> ADVANCED		LCR
MODE	:CONT	CONT
DRAW	:REAL	
DISP	:ON	

Settings

MODE	Measurement mode setting (p.120)
DRAW	Display timing setting (p.123)
DISP	LCD setting (p.124)

### 1.3.5 System Settings Screen

This screen is used to set the interface type.

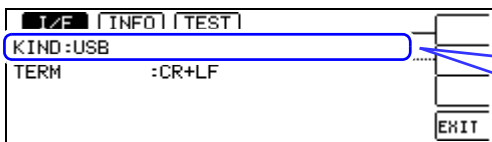

Settings

<b>USB</b>	USB Setting (p.171)
<b>GP-IB</b>	GP-IB Setting (p.171)
<b>RS-232C</b>	RS-232C Setting (p.171)
<b>LAN</b>	LAN Setting (p.171)
<b>PRINT</b>	Printer Setting (p.197)

Check the version of the instrument

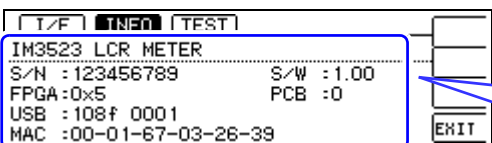

Settings

<b>S/N</b>	Serial No. (p.172)
<b>FPGA</b>	FPGA Version (p.172)
<b>USB</b>	USB ID (Vendor ID, product ID) (p.172)
<b>MAC</b>	MAC address (p.172)
<b>S/W</b>	Software Version (p.172)
<b>PCB</b>	Board version (p.172)

Self Check

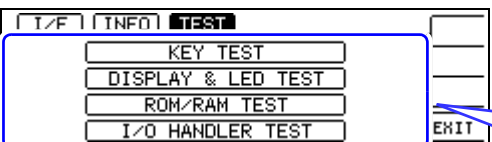

Settings

<b>KEY TEST</b>	Performs a key test (p.173)
<b>DISPLAY &amp; LED TEST</b>	Performs a screen display test (p.174)
<b>ROM/RAM TEST</b>	Performs a ROM/RAM test (p.175)
<b>I/O HANDLER TEST</b>	Performs an I/O test (p.176)



### 1.3.6 Comparator/BIN Settings Screen

#### Comparator Mode

When the **COMP/BIN** key is pressed during comparator measurement.

Settings	
HI	Upper Limit Value Setting (p.76)
LO	Lower Limit Value Setting (p.76)

#### BIN mode

When the **COMP/BIN** key is pressed during BIN measurement.

Settings		
No.	BIN number (p.83)	
HI	Upper Limit Value Setting (p.83)	
LO	Lower Limit Value Setting (p.83)	

### 1.3.7 Panel Load screen

When the **PANEL LOAD** key is pressed.

Settings			
No.	Panel No. (p.165)		
PANEL NAME	Panel name (p.165)		
TYPE	Save type (p.165)		
INFORMATION	Saved information (p.165)		

### 1.3.8 Compensation Settings Screen

When the **ADJ** key is pressed.

Settings	
OPEN	Open circuit compensation setting (p.125)
SHORT	Short circuit compensation setting (p.136)
LOAD	Load circuit compensation setting (p.145)
CABLE	Cable length compensation setting (p.157)
SCALE	Scaling setting (p.158)

1.3.9 Information Screen

AC1 Screen

This screen is displayed when the **INFO** key is pressed.

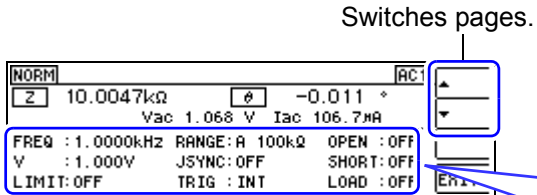

Settings	
<b>FREQ</b>	Frequency
<b>V</b>	Signal level
<b>LIMIT</b>	Limit value
<b>RANGE</b>	Measurement range
<b>JSYNC</b>	Judge Synchronous setting
<b>TRIG</b>	Trigger Setting
<b>OPEN</b>	Open Circuit Compensation
<b>SHORT</b>	Short circuit compensation setting
<b>LOAD</b>	Panel load

AC2 Screen

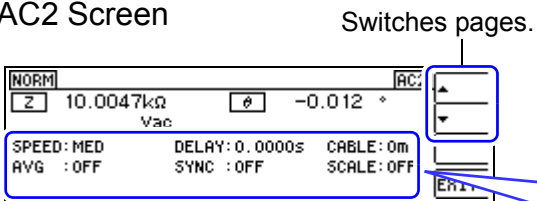

Settings	
<b>SPEED</b>	Measurement Speed
<b>AVG</b>	Average setting
<b>DELAY</b>	Trigger delay
<b>SYNC</b>	Trigger Synchronous Output Function
<b>CABLE</b>	Cable length compensation
<b>SCALE</b>	Scaling

DC Screen

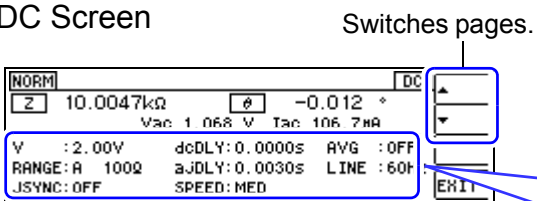

Settings	
<b>V</b>	Signal level
<b>RANGE</b>	Measurement range
<b>JSYNC</b>	Judgment synchronization setting
<b>dcDLY</b>	DC delay
<b>ajDLY</b>	Adjust delay
<b>SPEED</b>	Measurement Speed
<b>AVG</b>	Average setting
<b>LINE</b>	Line frequency

When **INFO** is pressed

Pressing **INFO** key on the Information screen causes the screen to transition as follows:

AC1 screen → AC2 screen → DC screen → Back to Measurement screen

# Measurement Preparations

# Chapter 2

2

Chapter 2 Measurement Preparations

Be sure to read the "Operating Precautions" (p. 5) before installing and connecting this instrument. Refer to "Appendix9 Rack Mounting"(p. A13) for rack mounting.

## 2.1 Preparation Flowchart

1 Installing the Instrument (p.5)

2 Connecting the Power Cord (p.23)

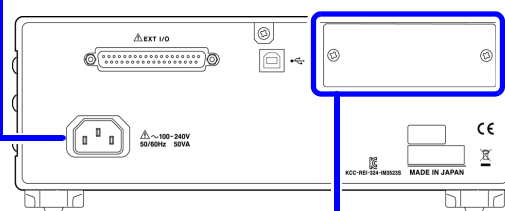

3 Connect measurement cables, optional Hioki probes or test fixture (p.24)

4 Connect the external interface (as needed)

**NOTE** Confirm that the instrument is turned off.

- USB Cable
- GP-IB Cable (when Z3000 connected only)
- RS-232C Cable (when Z3001 connected only)
- LAN Cable (when Z3002 connected only)
- EXT I/O (p.177)
- Printer (when Z3001 connected only)(p.195)

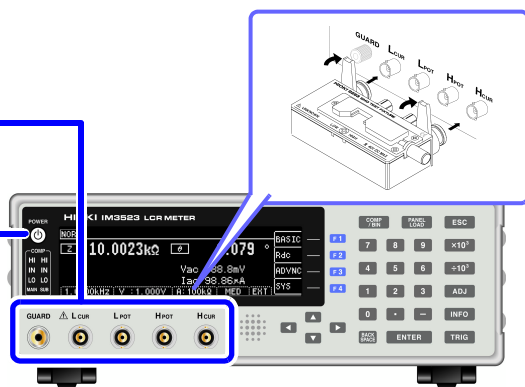

5 Turning Power On (p.26)

Make instrument settings (p.31)

Connect to the test sample.  
Remove the test sample and turn off the power after use. (p.26)

**NOTE** When performing DC resistance measurement, be sure to set the line frequency before starting measurement.  
**See** "4.3.4 Setting the Line Frequency" (p. 70)

# 2.2 Pre-Operation Inspection

Please read the "Operating Precautions" (p. 5) before use.

Before using the instrument for the first time, verify that it operates normally to ensure that no damage occurred during storage or shipping. If you find any damage, contact your dealer or Hioki representative.

## 1 Peripheral Device Inspection

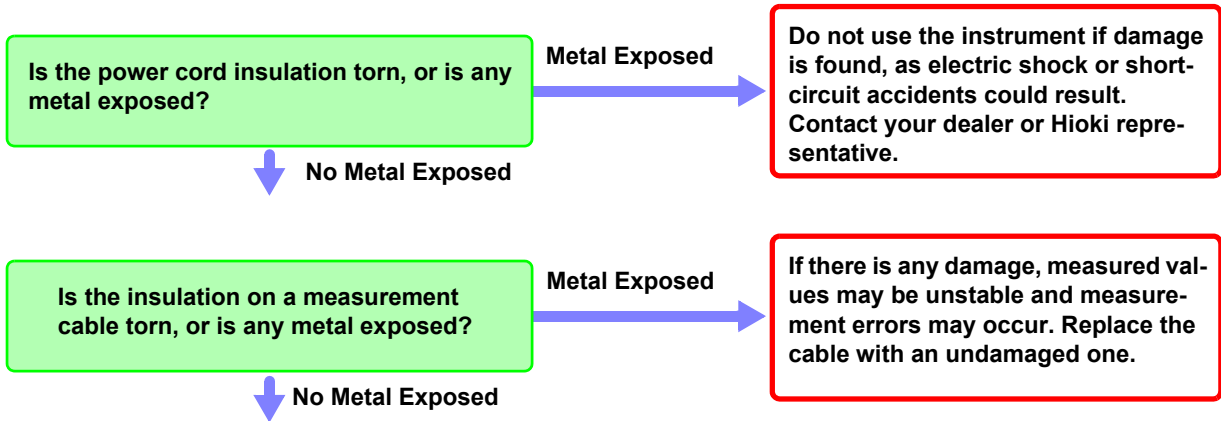

## 2 Instrument Inspection

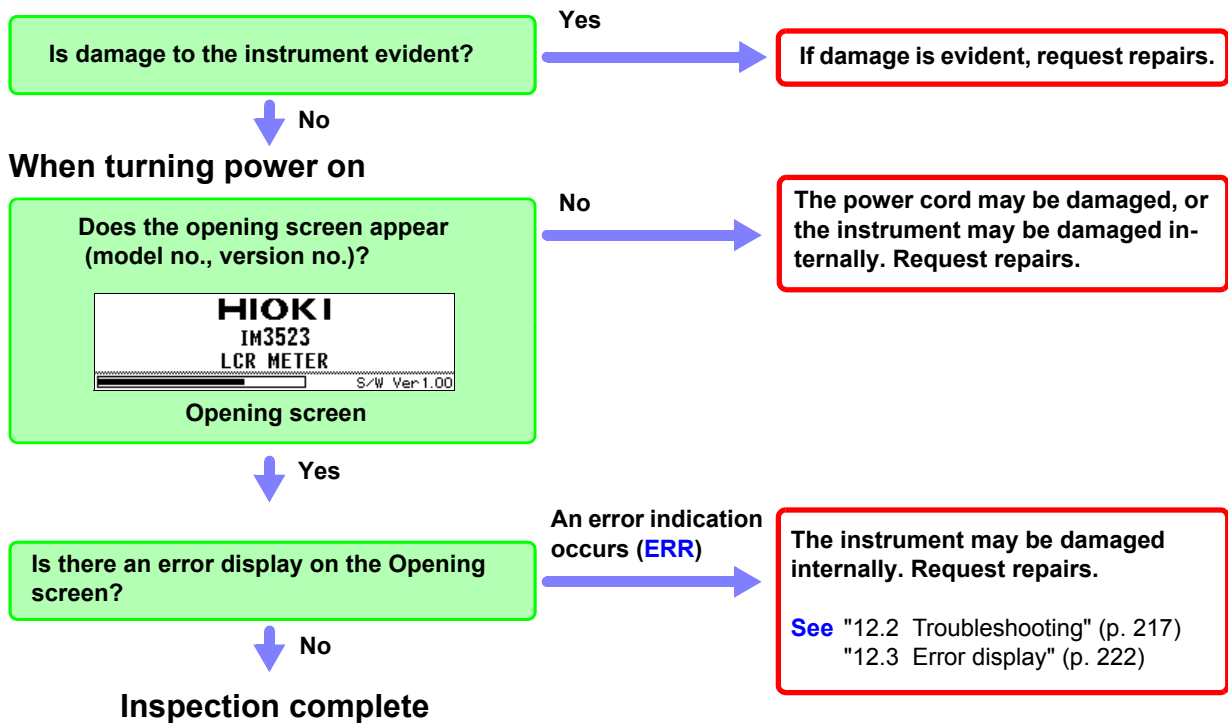

## 2.3 Connecting the Power Cord



Please read "Before Turning Power On" (p. 6), "About Handling of Cords and Fixtures" (p. 7) before connecting the power cord.

Connect the power cord to the power inlet on the instrument, and plug it into an outlet.

### Connection Procedure

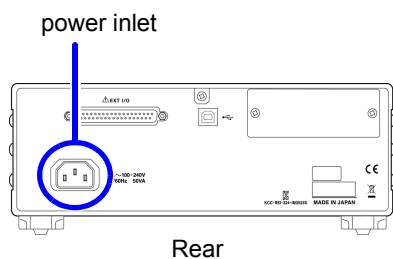

- 1 Confirm that the power cord matches the line voltage, and plug it into the power inlet on the instrument. (AC100 V to 240 V)
- 2 Plug the other end of the power cord into an outlet.

The POWER button on the instrument's front panel will flash red.

If power is interrupted while the instrument is operating, it will start back up immediately when power is restored. (when the circuit breaker is turned back on, etc.)

# 2.4 Connect measurement cables, optional Hioki probes or test fixture



Be sure to read the “Usage Notes” (p. 7) before connecting measurement cables, probes or test fixture.

Connect your measurement cables, optional Hioki probes or test fixture to the measurement terminals. Refer to "5. Accessories, Options" (p. 205) for details.

See the instructions provided with the fixture for operating details.

## Connecting a measurement cable/fixture

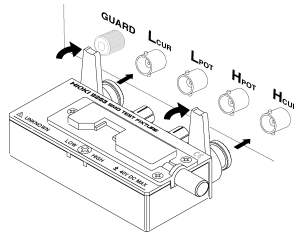
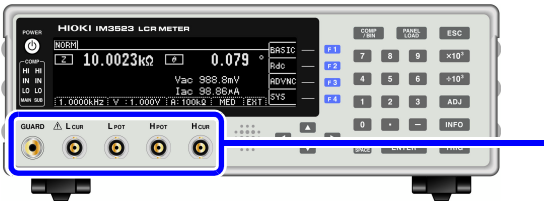

Connect directly to the measurement jacks with the label side up, and affix with the levers on the left and right.

(When using the optional 9140-10 or L2001)  
Connect the red plugs to the H<sub>CUR</sub> and H<sub>POT</sub> jacks, and the black plugs to the L<sub>CUR</sub> and L<sub>POT</sub> jacks.

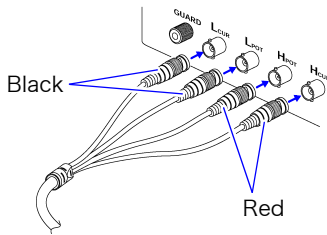

(When using the optional 9500-10)  
BNC plug of H<sub>CUR</sub>, H<sub>POT</sub>, L<sub>CUR</sub> and L<sub>POT</sub> connected properly to the measurement terminals of each of the instruments.

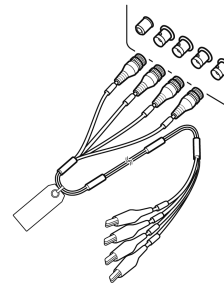

## Points to pay attention to when making your own probe

- Use 50 Ω coaxial cable for the measurement cable.
- Ensure that the length of the cable is the same as that set for the instrument. (1m)
- The cable length is defined as the length from the tip of the BNC connector to the tip of the probe electrode.
- Make the portion of the core wire that is exposed as short as possible.
- Connect the H<sub>CUR</sub>, L<sub>CUR</sub>, H<sub>POT</sub>, and L<sub>POT</sub> shield pairs at the measurement object side.  
(Ensure that a shield is not connected to a core wire.)

- NOTE**
- As a rule, only HIOKI-brand probes, fixtures, and other components (options) should be used. Use of probes that you have built yourself may prevent the instrument from performing in a matter that satisfies its specifications.  
See "5. Accessories, Options" (p. 205)
  - If all four terminals are disconnected, a meaningless number may be displayed on the unit.

### Measurement Terminal Configuration

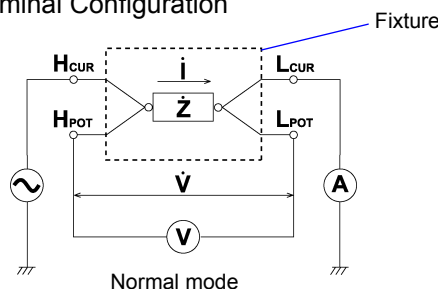

## 2.5 Connecting an Interface



Be sure to read the "About interfaces (option)" (p. 8) before connecting measurement cables, probes or test fixture.

Read this section before installing or replacing an optional interface or removing the interface and using the instrument without it.

2

Chapter 2 Measurement Preparations

### Installing an interface

You will need: A Phillips head screwdriver

Rear

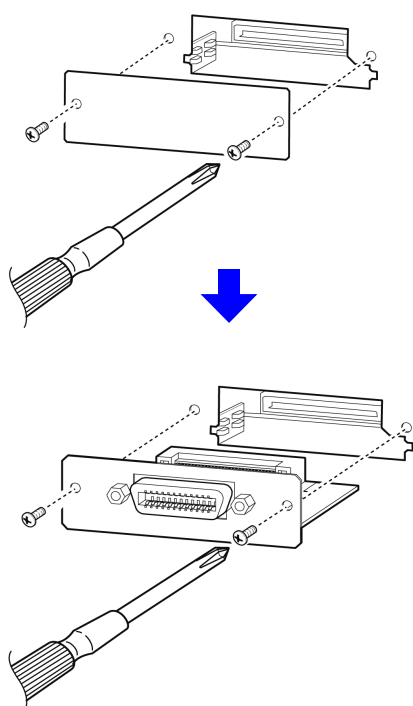

- 1** Unplug the instrument's power cord from the wall outlet. Disconnect connection cords.
- 2** Remove the blank panel.
- 3** Paying attention to the orientation of the interface, inset it firmly into place.
- 4** Secure the interface in place by tightening the two fixing screws with a Phillips head screwdriver.

#### When removing the interface:

Unplug the power cord from the wall outlet and perform the above procedure in reverse to remove the interface.

### When a removed interface will not be used

Rear

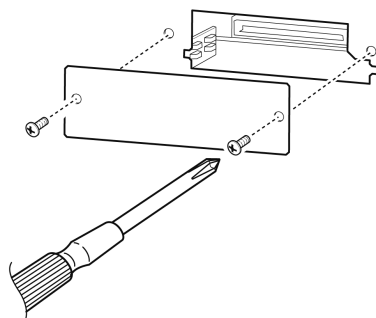

- 1** Unplug the instrument's power cord from the wall outlet. Disconnect connection cords.
- 2** Attach the blank panel and secure it in place by tightening the two fixing screws with a Phillips head screwdriver.

Making measurements without reattaching the blank panel may prevent the instrument from performing to its specifications.

You can check information about the interface installed in the instrument on the screen.

See "8.1 Setting the Interface" (p. 171), "8.2 Checking the Version of the Instrument" (p. 172)

## 2.6 Turning the Power On and Off



Connect the power cord and voltage and current measurement cables before turning the instrument on.

### Turning main power on

Press the **POWER** button (it lights green).

When the power is turned on, the same setting as when the power was last turned off appears.

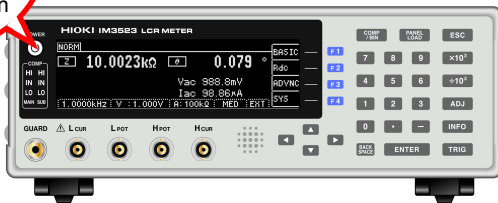

To ensure that measurements fulfill the degree of accuracy described in the specifications, allow the instrument to warm up for at least 60 minutes after it is turned on.

### Turning main power off

**ON** the main power in the state, hold down the front **POWER** switch 2 seconds approximately. (it lights red)(Standby state).

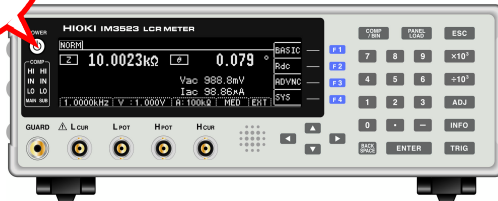

Disconnect the power cord from the outlet to extinguish the POWER button light.

When power is turned on again, operation resumes with the same settings as when last turned off.

#### Standby state

The instrument is in the standby state when measurement has been stopped and the instrument is waiting for POWER button input to be detected. To allow POWER button input to be detected, some internal circuitry is operating with power consumption of approximately 4 W.

**NOTE** If a power outage (e.g., breaker trip) occurs when the instrument is on, it will automatically turn on again when power is restored. (without pressing the POWER button)



# Measurement Example

## Chapter 3

### Measuring a Laminated Ceramic Capacitor

Necessary items : 9263 SMD test fixture  
Laminated ceramic capacity you want to measure

- 1 Connect the 9263 SMD test fixture to the measurement terminals.

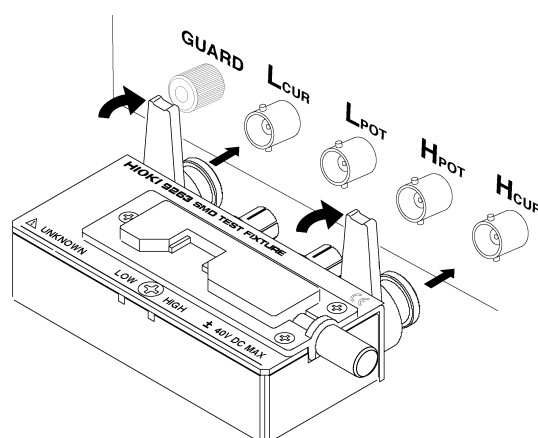

For the connection procedure, refer to the instruction manual supplied with the fixture.

- 2 Open the Basic Settings screen.



F1 ► Displays the Basic Settings screen.

- 3 Set the measurement conditions.

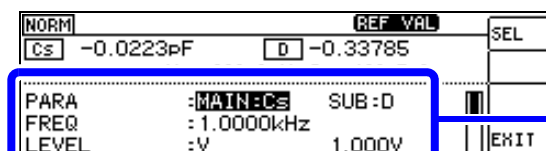

Select

<b>PARA</b>	Display parameters	:MAIN :Cs :SUB :D
<b>FREQ</b>	Measurement frequency	:1.0000 kHz
<b>LEVEL</b>	Measurement signal mode: Open circuit voltage mode (V) Measurement signal level:1.000 V	
<b>LIMIT</b>	Voltage and current limit	:OFF
<b>RANGE</b>	Measurement range	:AUTO
<b>JUDGE SYNC</b>	Judgment synchronization function	:OFF
<b>TRIG</b>	Trigger	:INT
<b>LIST</b>	Displays the LIST Settings screen.	

**4** Select [LIST] on the Basic screen to open the LIST Settings screen.

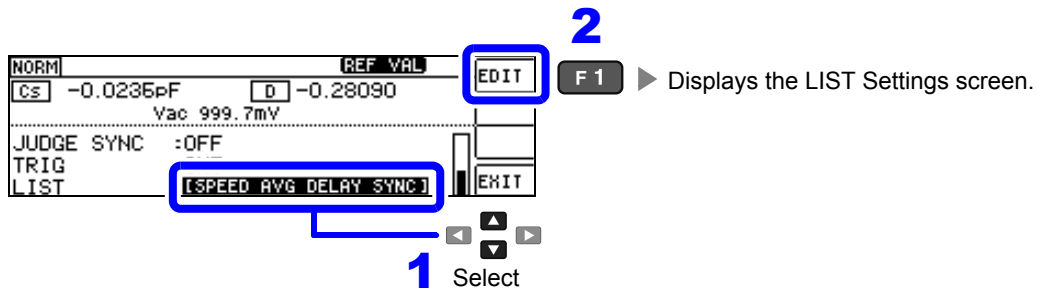

**5** Set the measurement conditions for the respective ranges.

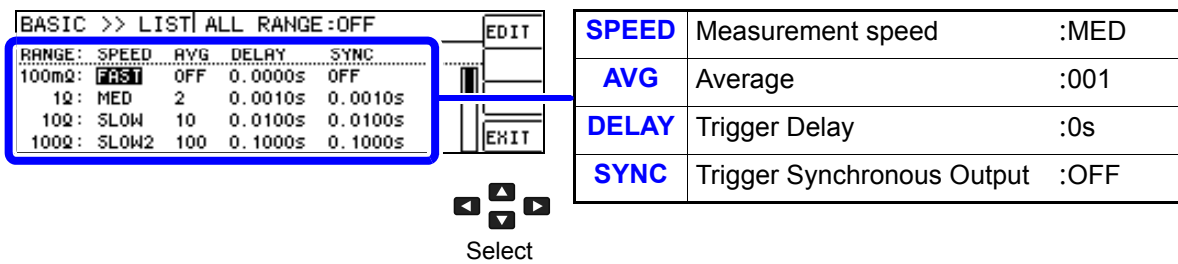

**6** Connect the test sample to the 9263 SMD test fixture.

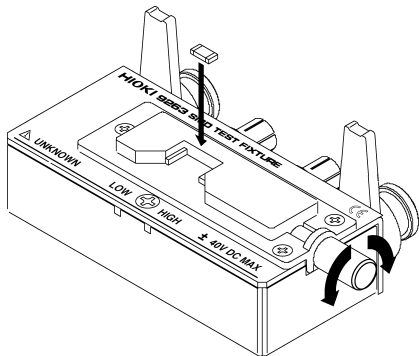

For the connection procedure of the test sample, refer to the instruction manual supplied with the fixture.

**7** Check the measurement results.

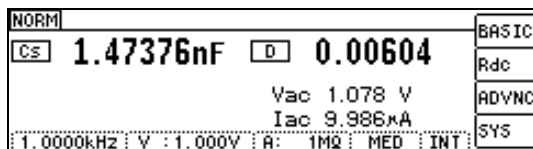

- When you want to judge the measurement results  
 See "4.4.1 Making Judgments Based on Upper and Lower Limit Values (Comparator Measurement Mode)" (p. 76)
- When you want to save the measurement results  
 See "4.5.1 Saving Measurement Results (Memory function)" (p. 97)

# LCR Function

# Chapter 4

## 4.1 About LCR function

The LCR function allows you to measure the impedance, phase angle, and other items by applying any frequency or level (effective value) signal to the element you want to measure. This function is suitable for evaluating the passive element of a capacitor, coil, or the like.

### Measurement screen

The Measurement screen allows you to make measurements while reviewing measurement conditions. When the instrument is turned back on, the display will reflect the measurement mode that was in use when the power was turned off. For more information about the screen layout, see (p.12).

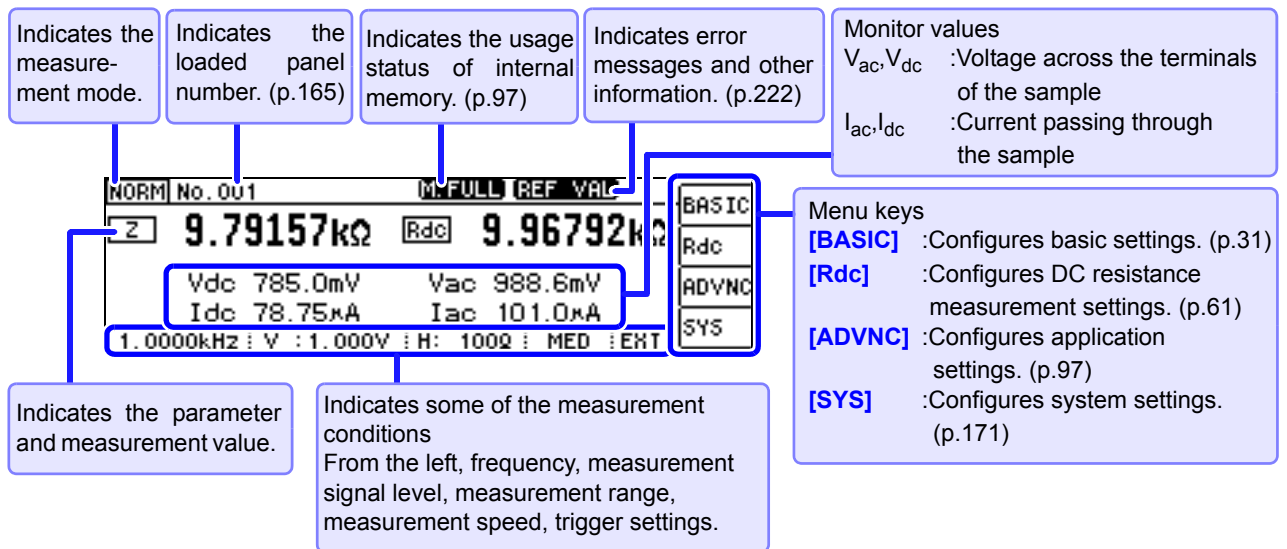

4.1 About LCR function

Keys that can be used on the Measurement screen

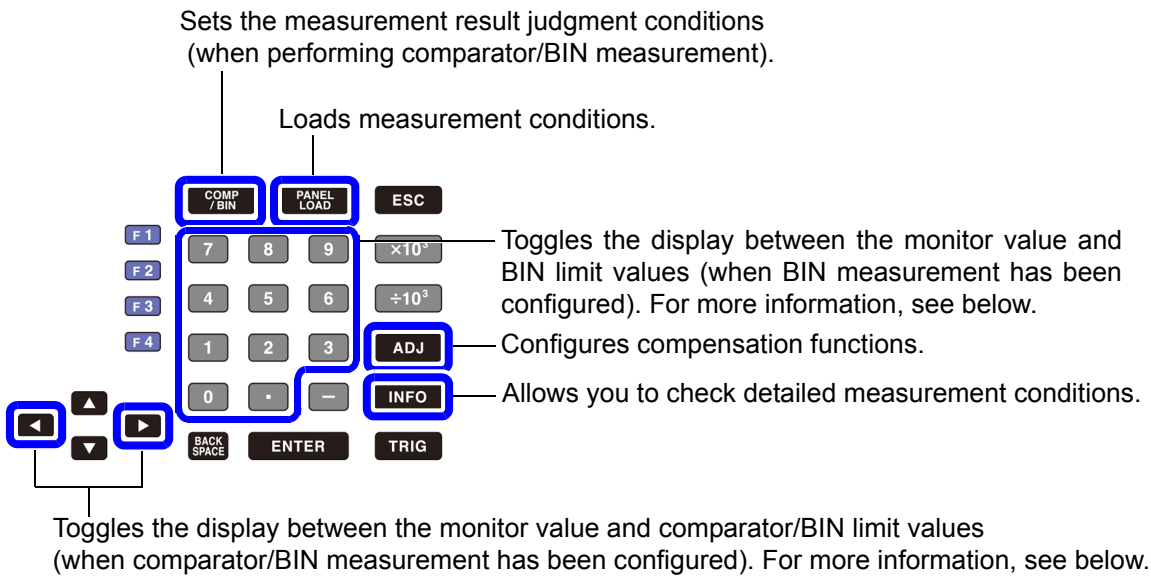

When performing comparator measurement.  
(Switch between the limit and monitor values with the ◀ ▶ keys.)

COMP	10.0026kΩ	0.079	BASIC
z			Rdc
HI : 10.0050k	HI : 90.0000m		ADVNC
LO : 9.99500k	LO : 60.0000m		SYN

Limit values

COMP	10.0026kΩ	0.079	BASIC
z			Rdc
Vac 987.5mV	Iac 98.72mA		ADVNC
			SYN

Monitor values

When performing BIN measurement.  
(Switch between the limit and monitor values with the tenkey ( 0 to 9 , . ) or the ◀ ▶ keys.)

BIN	10.0026kΩ	0.080	BASIC
z			Rdc
HI : 10.0000k	HI : 90.0000m		ADVNC
LO : 9.90000k	LO : 60.0000m		SYN

BIN1 Limit values

BIN	10.0026kΩ	0.080	BASIC
z			Rdc
HI : 11.0000k	HI : 90.0000m		ADVNC
LO : 9.00000k	LO : 60.0000m		SYN

BIN10 Limit values

BIN	10.0026kΩ	0.080	BASIC
z			Rdc
Vac 988.5mV	Iac 98.82mA		ADVNC
			SYN

Monitor values

0 to 9 : Allow you to check the BIN limit values. ( 0 : BIN10 )  
 . : Allows you to check the monitor value.

**NOTE** When the measurement value is outside the guaranteed accuracy range, **REF VAL** will be shown on the error message display. If you encounter this issue, the following factors may be at play. Change the measurement conditions after checking the guaranteed accuracy range as described in "11.2 Measurement Range and Accuracy" (p.206), or use the measurement value as a reference value.

- If the measurement signal level is too low: Increase the measurement signal level.
- If the current measurement range (when using the HOLD setting) is not appropriate: Set the range to the optimal measurement range using AUTO ranging or change the measurement range manually.

# 4.2 Setting Basic Settings of Measurement Conditions

**NOTE** Measurement conditions for DC resistance measurement are configured on a different screen.  
 See "4.3 Setting DC Resistance Measurement" (p.61)

## 4.2.1 Setting Display Parameters

You can select a main and sub parameter from the 15 measurement parameters to display.  
 See "Appendix1 Measurement Parameters and Calculation formula"(p. A1)  
 "Appendix7 Series Equivalent Circuit Mode and Parallel Equivalent Circuit Mode"(p. A10)

**1** Open the Basic Settings screen.

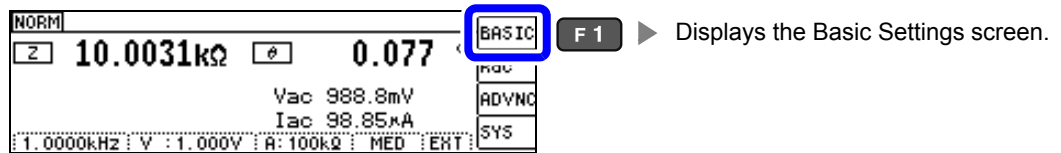

**2** Select [MAIN] under [PARA].

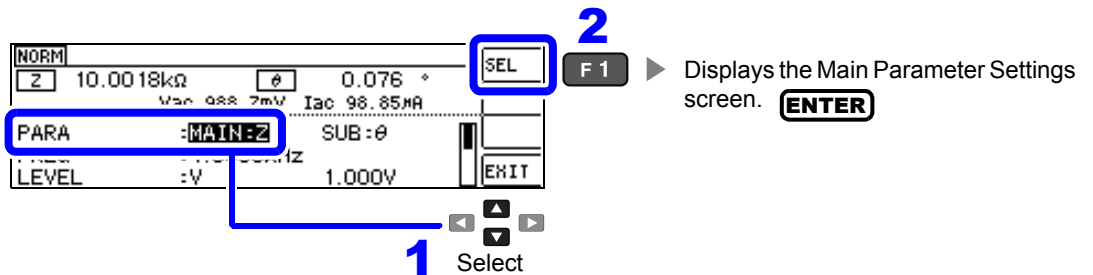

**3** Set the main parameter.

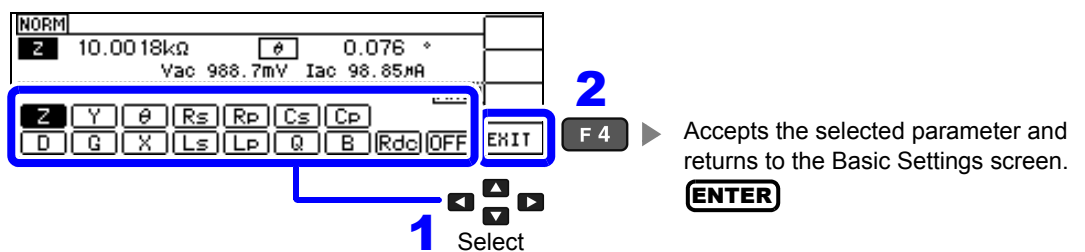

## 4.2 Setting Basic Settings of Measurement Conditions

**4** Select [SUB] under [PARA].

**2** Displays the Sub Parameter Settings screen. **ENTER**

**1** Select

**5** Set the sub parameter.

**4** Accepts the selected parameter and returns to the Basic Settings screen. **ENTER**

Select

List of parameters

<b>Z</b>	Impedance ( $\Omega$ )	<b>G</b>	Conductance (S)
<b>Y</b>	Admittance (S)	<b>X</b>	Reactance ( $\Omega$ )
<b>θ</b>	Impedance phase angle ( $^\circ$ )*	<b>Ls</b>	Inductance in series equivalent circuit mode (H)
<b>Rs</b>	Effective resistance in series equivalent circuit mode = ESR ( $\Omega$ )	<b>Lp</b>	Inductance in parallel equivalent circuit mode (H)
<b>Rp</b>	Effective resistance in parallel equivalent circuit mode ( $\Omega$ )	<b>Q</b>	Q factor
<b>Cs</b>	Static capacitance in series equivalent circuit mode (F)	<b>B</b>	Susceptance (S)
<b>Cp</b>	Static capacitance in parallel equivalent circuit (F)	<b>Rdc</b>	DC Resistance ( $\Omega$ )
<b>D</b>	Loss coefficient = $\tan\delta$	<b>OFF</b>	Display no measurement parameter in the chosen position.

\* The phase angle  $\theta$  is shown based on the impedance Z. When performing measurements using admittance Y as the reference, the sign of the impedance Z phase angle  $\phi$  will be reversed.

### 4.2.2 Setting the Measurement frequency

Set the frequency of the signal to apply to the test sample.  
 For some test samples, the value may vary depending on the measurement frequency.

You can enter the frequency using either digit or tenkey input. **10KEY** **DIGIT**

#### Setting the frequency with tenkey input

- 1 Open the Basic Settings screen.

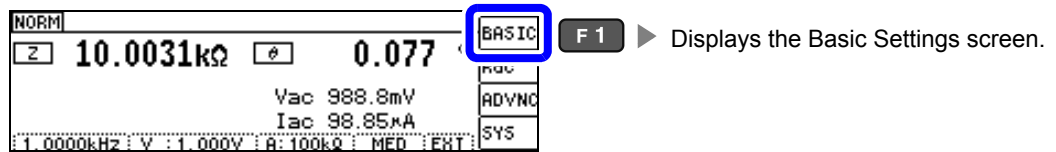

- 2 Select **[FREQ.]**.

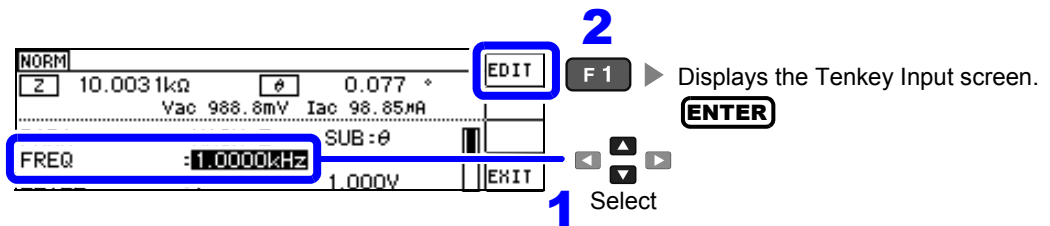

- 3 The Tenkey Input screen will be displayed.

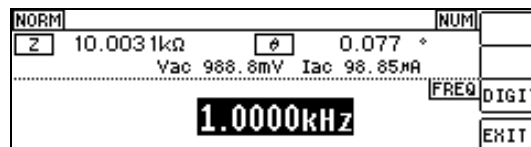

## 4.2 Setting Basic Settings of Measurement Conditions

**4** Enter the desired value with the tenkey and accept it with the **ENTER** key. **10KEY**  
 Settable range: 40 Hz to 200 kHz

Accepts the entered value

If you make a mistake:  
 Press **BACK SPACE** key and reenter the value.

1 5 . 5 ×10<sup>3</sup> ENTER  
 1 ▶ 15 ▶ 15. ▶ 15.5 ▶ 15.5 k ▶ 15.500kHz

- The **×10<sup>3</sup>** **÷10<sup>3</sup>** keys will be disabled until you enter a value.
  - If you set a frequency of 200 kHz or higher, the frequency will automatically revert to 200 kHz.
  - If a frequency of less than 40 Hz is set, the value will be automatically changed to 40 Hz.
- "Chapter 11 Specifications" (p.201)

**5**

**EXIT** **F 4** ▶ Returns to the Basic Settings screen.  
**ENTER**



Set each digit (DIGIT)

1 Open the Basic Settings screen.

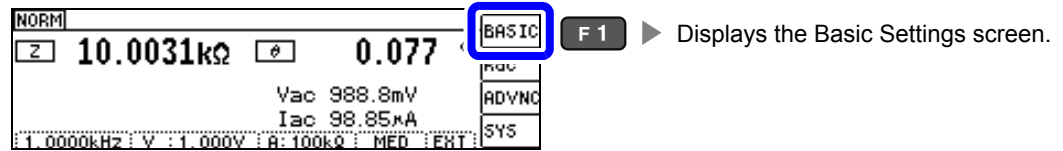

2 Select [FREQ].

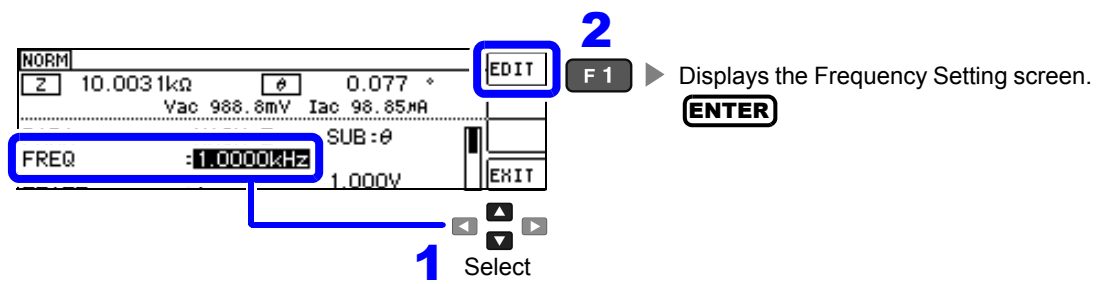

3 Select [DIGIT].

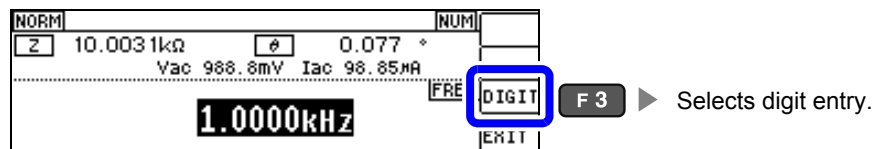

4 Enter the desired value. **DIGIT**  
Settable range: 40 Hz to 200 kHz

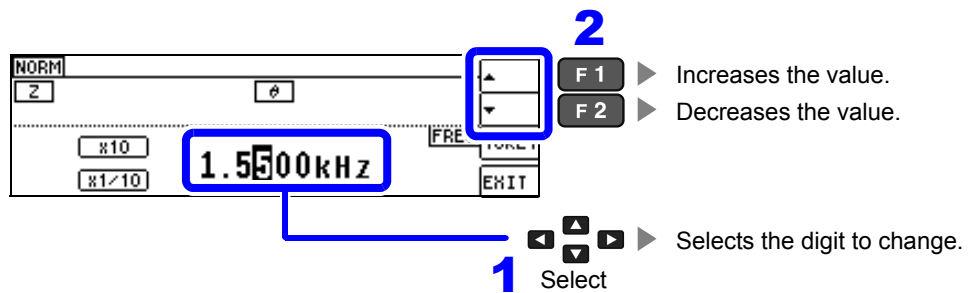

**NOTE** The digits in the measurement frequency can also be changed using the **▲ ▼** keys.

# 36

## 4.2 Setting Basic Settings of Measurement Conditions

**5** Change the unit and decimal point.

**2** **F 1** ▶ Multiplies the measurement frequency by 10 or  $\frac{1}{10}$ .

**1** Select

**6**

**F 4** ▶ Returns to the Basic Settings screen.

### 4.2.3 Setting the Measurement signal level

The value of the test signal level may change according to the sample which is being tested. This instrument is possible to vary the level of the test signal applied to the object under test over a wide range using the following three methods. Selecting constant voltage or constant current mode will result in increased measurement times due to use of software feedback control.

**Open circuit voltage mode (V)**

The value of the open circuit voltage is set.

**Constant voltage mode (CV)**

The value of the voltage between the terminals of the object under test is set.

**Constant current mode (CC)**

The value of the current flowing through the object under test is set.

**CAUTION** Do not switch between V, CV and CC while the test sample is still connected to the measurement terminals because doing so may damage the test sample.

**NOTE**

- In constant voltage (CV) mode, the generated voltage is controlled using software feedback so that the set constant voltage value is applied. Since the voltage used for the most recent measurement is output as the generated voltage initial value, a voltage in excess of the set constant voltage value may be applied before feedback control is active if the sample's impedance is higher than that of the last measured sample.
- In constant current (CC) mode, the generated voltage is controlled using software feedback so that the set constant current value is applied. Since the voltage used for the most recent measurement is output as the generated voltage initial value, a current in excess of the set constant current value may be applied before feedback control is active if the sample's impedance is lower than that of the last measured sample.

**1** Open the Basic Settings screen.

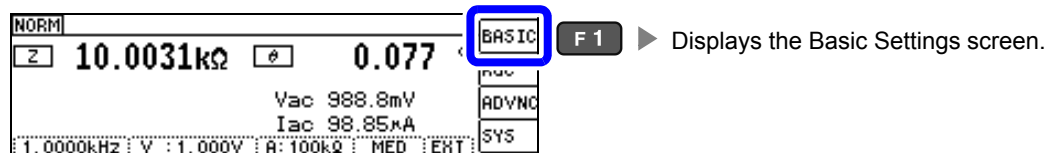

**2** Select [LEVEL].

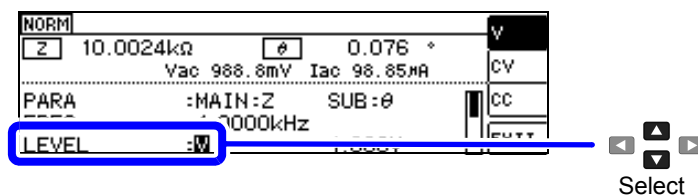

**3** Select the measurement signal mode.

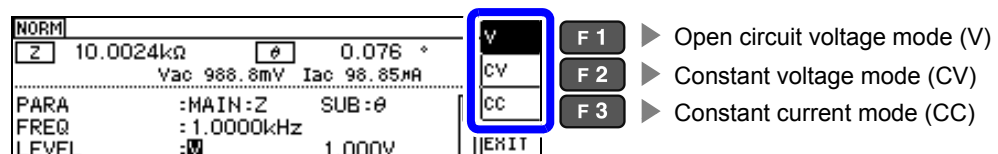

4.2 Setting Basic Settings of Measurement Conditions

- 4** Select the [LEVEL] voltage or current value and change the value. **DIGIT**  
 The accuracy of testing varies according to the test signal level.  
 See "11.2 Measurement Range and Accuracy" (p.206)

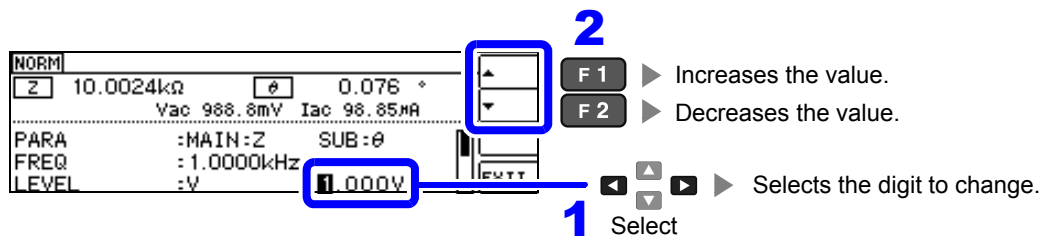

Measurement signal level range

Measurement signal mode	Setting range
V, CV	0.005 V to 5.000 V
CC	0.01 mA to 50.00 mA

**5**

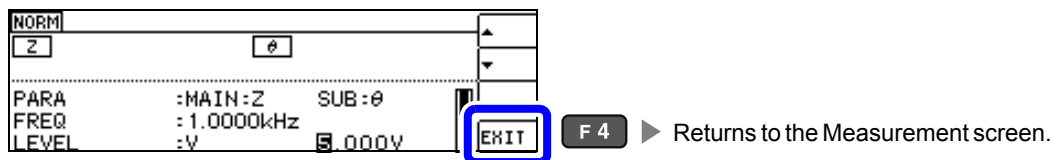

**NOTE**

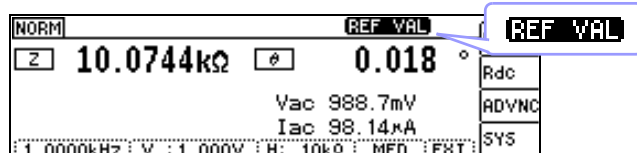

If the measurement value is outside the accuracy guarantee, **REF VAL** will be displayed at the top of the screen. Check the accuracy guarantee range in "11.2 Measurement Range and Accuracy" (p.206) and either change the measurement conditions or make the measurement value a reference value.

- If the measurement signal level is too low: Increase the measurement signal level.
- If the current measurement range (when using the HOLD setting) is not appropriate: Set the range to the optimal measurement range using AUTO ranging or change the measurement range manually.

About the test signal mode

Relationship between the measurement signal mode of the instrument and the sample is as follows.

**Open circuit voltage mode (V)**  
 This voltage value is the value which is applied across the two terminals of the series combination of the object which is being tested and the output impedance. As for the voltage which is applied across the terminals of the object which is being tested (by itself), if required, you should either check the monitor voltage value, or select constant voltage (CV) and set a voltage value across these terminals.

**Constant current mode (CC)**  
 You should select this if you wish to set the current passing through the object to be tested to a constant value.

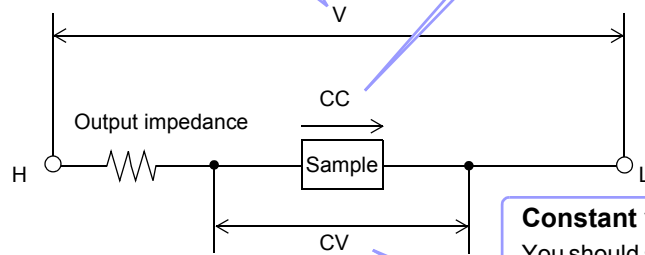

**Constant voltage mode (CV)**  
 You should select this if you wish to set the voltage across the terminals of the object to be tested to a constant value.

For setting range and accuracy

Open circuit voltage mode (V) and Constant voltage mode (CV) setting

Open circuit voltage setting range	Open circuit voltage accuracy	Output impedance
0.005 V to 5.000 V	±10%rdg.±10 mV	100 Ω ±10 Ω

**NOTE** Depending on the sample, you may not be able to perform constant voltage measurement. In this situation, the following mark will be displayed:

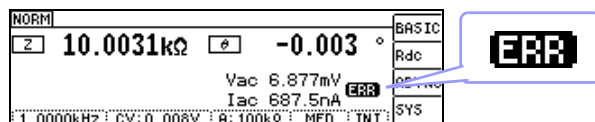

Constant voltage measurement will not be performed. Change the constant voltage level so that it is less than or equal to the displayed Vac monitor values.

Example: Range in which constant voltage operation is supported when measuring a 1 μF C at 10 kHz

The sample impedance Zm is as follows:

$$Z_m = R_m + jX_m = 0[\Omega] - j15.9[\Omega] \qquad X_m = \frac{-1}{(2\pi fC)}$$

The impedance Zm' observed from the generator is as follows:

$$Z_m' = R_o + Z_m = 100[\Omega] - j15.9[\Omega] \qquad R_o: \text{Output resistance (100 } [\Omega])$$

Accordingly, the voltage Vm across both leads of the sample is as follows:

$$V_m = \frac{|Z_m| \times V_o}{|Z_m'|} = \frac{15.9[\Omega] \times V_o}{101.3[\Omega]} \qquad V_o: \text{generator output}$$

Because the generator output voltage range is 5 mV to 5 V for 10 kHz, the CV operation range per the above expression is Vm = 0.8 mV to 0.78 V.

## 4.2 Setting Basic Settings of Measurement Conditions

### Constant current mode (CC) setting

However, the constant current operation range differs depending on the test sample to be measured.

Constant current setting range	Constant current accuracy	Output impedance
0.01 mA to 50.00 mA	±10%rdg. ±10 μA	100 Ω ±10 Ω

**NOTE** Depending on the sample, you may not be able to perform constant current measurement. In this situation, the following mark will be displayed:

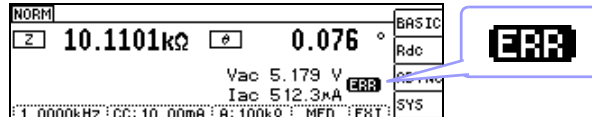

Constant current measurement will not be performed. Change the constant current level so that it is less than or equal to the displayed  $I_{ac}$  monitor value.

Example:

Range in which constant current operation is supported when measuring a 1 mH L at 1 kHz  
The sample impedance  $Z_m$  is as follows:

$$Z_m = R_m + jX_m = 0[\Omega] - j6.28[\Omega] \qquad X_m = 2\pi fL$$

The impedance  $Z_m'$  observed from the generator is as follows:

$$Z_m' = R_o + Z_m = 100[\Omega] - j6.28[\Omega] \qquad R_o: \text{output resistance (100 } [\Omega])$$

Accordingly, the current  $I_m$  across both leads of the sample is as follows:

$$I_m = \frac{V_o}{|Z_m'|} = \frac{V_o}{100.2[\Omega]} \qquad V_o: \text{generator output}$$

Since the generator output voltage range is 5 [mV] to 5 [V] based on the "Open circuit voltage mode (V) and Constant voltage mode (CV) setting" (p. 39) table, constant current operation is supported for  $I_m$  values of 49.9 [μA] to 49.9 [mA] as per the above equation.

### 4.2.4 Limiting the Voltage or Current Applied to the Sample (Limit Values)

Depending on the measurement signal level, in some cases it is possible to damage the sample which is being tested by applying to it a voltage or a current greater than its rated value.

To avoid such damage, you can set a limit value to limit the voltage applied to the sample or the current that flows to the sample.

Enabling the limit function will result in increased measurement times due to use of software feedback control.

When open circuit voltage mode (V) or constant voltage mode (CV) is set

Set the current limit.

When constant current mode(CC) is set

Set the voltage limit.

- 1 Open the Basic Settings screen.



- 2 Select [LIMIT].

- When the measurement signal mode is a voltage (V, CV)

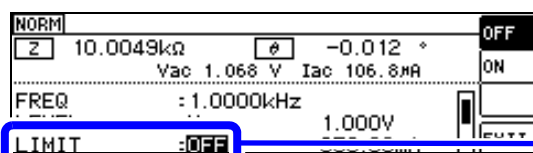

- When the measurement signal mode is a current (CC)

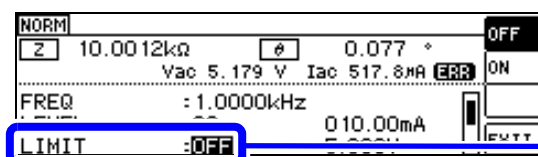

Select

- The measurement signal level can be checked using the monitor display.
- The monitor display is different for V, CV, and CC.

#### **NOTE**

First set the measurement signal mode, and thereafter set the voltage or current limit. The setting for voltage or current limit changes automatically to current or voltage limit, according to the present measurement signal mode setting.

See "4.2.3 Setting the Measurement signal level" (p.37)

4.2 Setting Basic Settings of Measurement Conditions

3 Set the limit function to either [ON] or [OFF].

F 1 ▶ Disables the limit function.  
F 2 ▶ Enables the limit function.

4 Enter the current limit value or voltage limit value. **DIGIT**

F 1 ▶ Increases the value.  
F 2 ▶ Decreases the value.  
Select

Limit range

Measurement signal mode	Set limit	Setting range
V, CV	Current limit	0.01 mA to 50.00 mA
CC	Voltage limit	0.005 V to 5 V

Current limit accuracy

Frequency	Accuracy
40 Hz to 200 kHz	±10%rdg.±10 μA

Voltage limit accuracy

Frequency	Accuracy
40 Hz to 200 kHz	±10%rdg.±10 mV

When the limit function is on, the following marks may be displayed.

Example: When constant voltage mode (CV) setting

If the voltage or current which is applied to the sample under test exceeds the limit value (the current exceeding the limit value flows through the sample even when the open-circuit voltage is set to minimum value.)

Lower the measurement signal level so that the limit value is not exceeded.

If the test signal level which is being applied to the sample under test exceeds the limit value. Then the test signal level is stopped changing.

At this time, the voltage or current which exceeds the limit value is not being applied to the sample under test. You should change the test signal level so that it does not exceed the limit value.

5

F 4 ▶ Returns to the Measurement screen.



### 4.2.5 Setting the Measurement Range

There are three methods for setting the measurement range: AUTO, HOLD, and JUDGE SYNC.

AUTO	<p>The most suitable test range is set automatically. (Automatically sets the optimal measurement range when measuring samples whose impedance varies greatly with the frequency, or unknown samples.)</p>
HOLD	<p>Fixes the measurement range. The range is set manually. (Fixing the range allows high-speed measurement.)</p>
JUDGE SYNC	<p>Automatically sets the optimal range for the comparator and BIN measurement judgment standards. (Automatically sets the optimal range relative to the comparator and BIN measurement judgment standards when the sample's impedance varies greatly with the frequency.)</p>

**NOTE** The ranges are all defined in terms of impedance. Therefore, for a parameter other than impedance, the value is obtained by calculating from the measured values of  $|Z|$  and  $\theta$ .  
 See "Appendix1 Measurement Parameters and Calculation formula"(p. A1)

Using the HOLD or AUTO settings when the JUDGE SYNC setting is on causes the JUDGE SYNC setting to be automatically disabled.

4.2 Setting Basic Settings of Measurement Conditions

Setting AUTO Ranging

1 Open the Basic Settings screen.

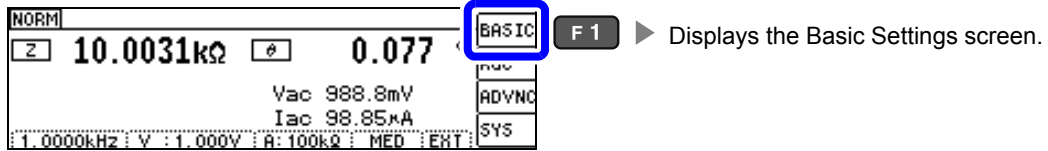

2 Select [RANGE].

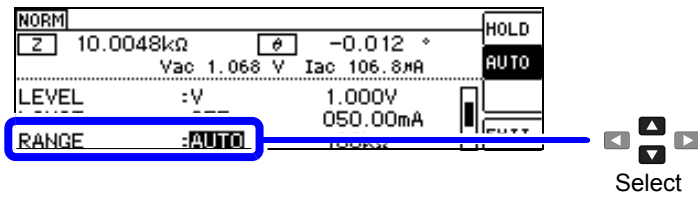

3 Set the measurement range to [AUTO].



- The ranges that can be selected vary with the frequency. (p.46)
- Outside the accuracy guarantee range, AUTO ranging may not function properly, preventing a range from being selected. If this occurs, check the accuracy guarantee range in "11.2 Measurement Range and Accuracy" (p.206) and change the measurement conditions.

4

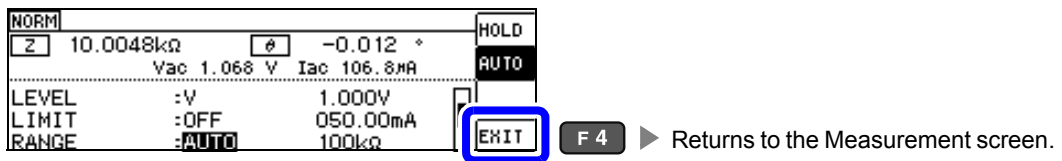

AUTO range limit function

The AUTO range limit function allows you to limit the AUTO ranging range. The AUTO range limit function can be set using communications commands only. It cannot be set from the instrument.

See Communications commands in the included LCR Application Disk documentation (: RANGE : AUTO : LIMi t)

4.2 Setting Basic Settings of Measurement Conditions

Setting HOLD Ranging

1 Open the Basic Settings screen.

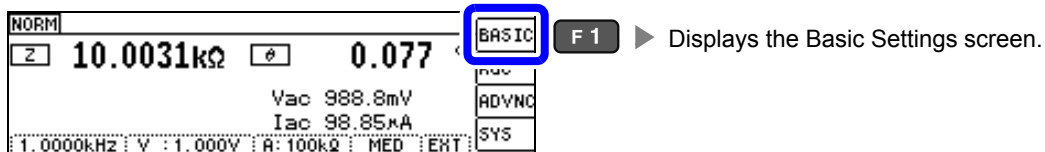

2 Select [RANGE].

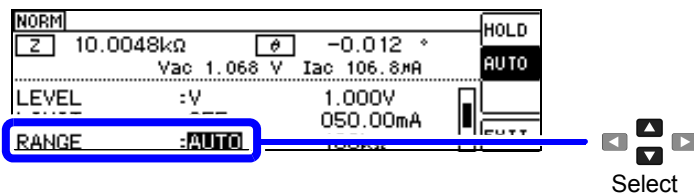

3 Set the measurement range to [HOLD].

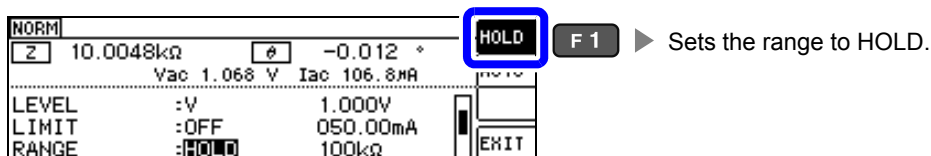

4 To select the measurement range.

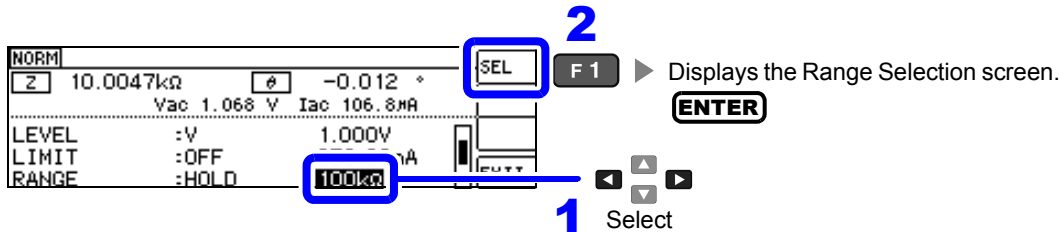

## 4.2 Setting Basic Settings of Measurement Conditions

**5** To select the measurement range.

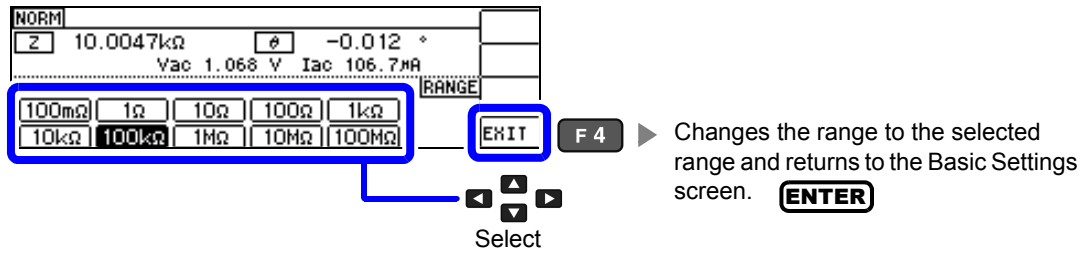

The ranges that can be selected vary with the frequency.

Frequency	Ranges that can be selected	Range Settings screen
DC 40.000 Hz to 10.000 kHz	All range	
10.001 kHz to 100.00 kHz	100 mΩ to 10 MΩ	
100.01 kHz to 200.00 kHz	100 mΩ to 1 MΩ	

Set the test range according to the combined impedance value of the sample to be tested and the test cables.

Range	Accuracy guaranteed range	AUTO Ranging Range
100 MΩ	8 MΩ to 200 MΩ	8 MΩ to
10 MΩ	800 kΩ to 100 MΩ	800 kΩ to 10 MΩ
1 MΩ	80 kΩ to 10 MΩ	80 kΩ to 1 MΩ
100 kΩ	8 kΩ to 1 MΩ	8 kΩ to 100 kΩ
10 kΩ	800 Ω to 100 kΩ	800 Ω to 10 kΩ
1 kΩ	80 Ω to 10 kΩ	80 Ω to 1 kΩ
100 Ω	8 Ω to 100 Ω	8 Ω to 100 Ω
10 Ω	800 mΩ to 10 Ω	800 mΩ to 10 Ω
1 Ω	80 mΩ to 1 Ω	80 mΩ to 1 Ω
100 mΩ	10 mΩ to 100 mΩ	0 Ω to 100 mΩ

## 4.2 Setting Basic Settings of Measurement Conditions

- NOTE**
- The guaranteed accuracy range varies depending on the measurement conditions. (p.202)
  - Changing the measurement range while the AUTO setting is enabled automatically enables the HOLD setting.
  - The measurement range is determined according to the test range setting. If the display for the measured value shows **OVERFLOW** or **UNDERFLOW**, that means that measurement cannot be performed using the currently set test range. Either you should set AUTO ranging so as to select the most suitable test range automatically, or you should set a more suitable test range manually. If a measurement result is outside the display range (p.201), **DISP OUT** is displayed.
  - The guaranteed accuracy range is for the measurement values before compensation.
  - The AUTO ranging range is the range within which the AUTO range is switched. When the AUTO range limit function is enabled, the range will not be switched outside the defined limit range.
  - In the case of a test sample whose impedance changes according to the frequency, when testing is being performed with HOLD set, it may happen, when the frequency is changed over, that measurement cannot be continued to be performed upon the same test range. You should change the test range if this happens.
  - The test range setting is made according to the combination of the impedances of the sample being tested and the test cables. Therefore it can happen that testing is not possible, if the test range is held with HOLD only upon the basis of the impedance of the sample under test. If this happens, you should change the test range, making reference to "6.1 Setting Open Circuit Compensation" (p.125) and "6.2 Short Circuit Compensation" (p.136).

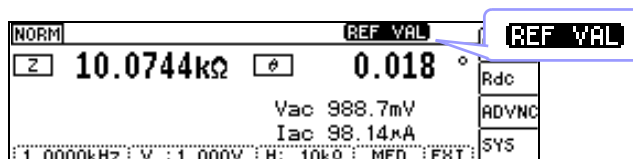

If the measurement value is outside the accuracy guarantee, **REF VAL** will be displayed at the top of the screen.

In this case, you should consider the following possible causes, and you should either change the test conditions while checking the accuracy assured ranges "11.2 Measurement Range and Accuracy" (p.206), or you should consider the measured values as values for reference.

- Perhaps the test signal level is too low, increase the test signal level.
- If the current measurement range (during HOLD setting) is not appropriate, set again in the AUTO range, or change the range by manual.

4.2 Setting Basic Settings of Measurement Conditions

JUDGE SYNC setting

When the judgment synchronization setting is enabled and you wish to set an optimal range based on the comparator or BIN measurement judgment standards, it is not necessary to set the range using the HOLD setting. When performing comparator or BIN measurement with a sample whose impedance varies greatly with the frequency, you can fix the measurement range to an optimal value relative to the judgment standard.

**NOTE** This setting is only available when the judgment standards have been set for comparator and BIN measurement. (p.75)  
 When judgment standards have been set for comparator and BIN measurement with this setting on, the range will be automatically switched to the optimal range. However, the AUTO range is used when no judgment standards have been set.

1 Open the Basic Settings screen.

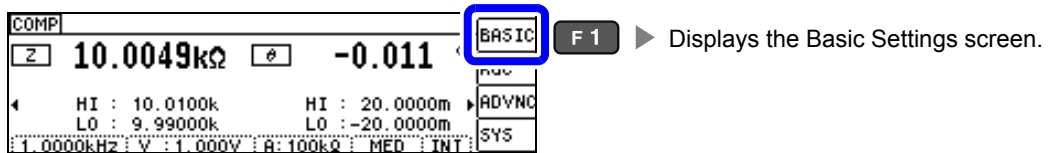

2 Select [JUDGE SYNC].

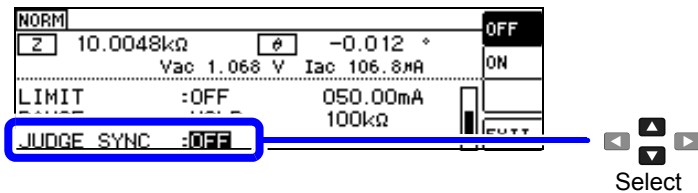

3 Turn the JUDG SYNC setting [OFF] or [ON].

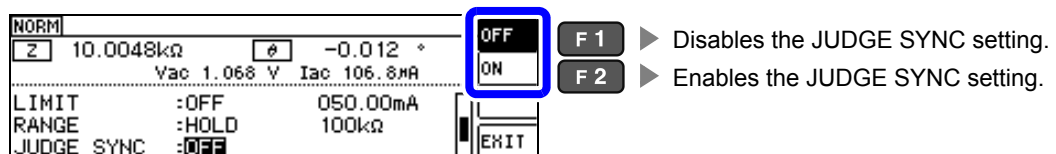

4

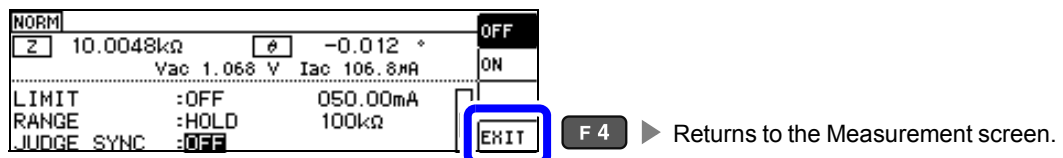

**NOTE**

- The ranges that can be selected vary with the frequency. (p.46)
- When only θ, D, or Q has been set, AUTO functionality is used.
- Because the phase angle cannot be calculated for some combinations of parameters, the range is determined from ideal values. For more information, see the table below.

See "Parameter combination conditions for the JUDGE SYNC setting" (p. 49)

## 4.2 Setting Basic Settings of Measurement Conditions

Parameter combination conditions for the JUDGE SYNC setting

	SUB Parameter																
	AC	OFF	Z	Y	Rs	Rp	X	G	B	Ls	Lp	Cs	Cp	$\theta$	D	Q	
MAIN Parameter	OFF	×	●	●	△	△	△	△	△	△	△	△	△	×	×	×	
	Z	●	●	●	△	△	△	△	△	△	△	△	△	●	●	●	
	Y	●	●	●	△	△	△	△	△	△	△	△	△	●	●	●	
	Rs	△	△	△	△	△	△	△	△	△	△	△	△	●	●	●	
	Rp	△	△	△	△	△	△	△	△	△	△	△	△	●	●	●	
	X	△	△	△	△	△	△	△	△	△	△	△	△	●	●	●	
	G	△	△	△	△	△	△	△	△	△	△	△	△	●	●	●	
	B	△	△	△	△	△	△	△	△	△	△	△	△	●	●	●	
	Ls	△	△	△	△	△	△	△	△	△	△	△	△	●	●	●	
	Lp	△	△	△	△	△	△	△	△	△	△	△	△	●	●	●	
	Cs	△	△	△	△	△	△	△	△	△	△	△	△	●	●	●	
	Cp	△	△	△	△	△	△	△	△	△	△	△	△	●	●	●	
	$\theta$	×	●	●	●	●	●	●	●	●	●	●	●	●	×	×	×
	D	×	●	●	●	●	●	●	●	●	●	●	●	●	×	×	×
	Q	×	●	●	●	●	●	●	●	●	●	●	●	●	×	×	×

×	Invalid setting (treated as AUTO range)
△	Invalid setting (treated as AUTO range) Set from ideal value since phase angle cannot be calculated.
●	Valid setting

4.2 Setting Basic Settings of Measurement Conditions

4.2.6 Measuring at User-specified Timing (Trigger Measurement)

Triggering is the process of controlling the start and stop of recording by specific signals or conditions (criteria). When recording is started or stopped by a specific signal, we say the trigger is “applied” or “triggering occurs”.

With this instrument, you can select the following two types of trigger.

- Internal Trigger**

▶

Automatically generates a trigger signal internally to repeat measurement.
- External trigger**

▶

Measurements are triggered by an external signal. The trigger is input manually or using external I/O or another interface.

1 Open the Basic Settings screen.

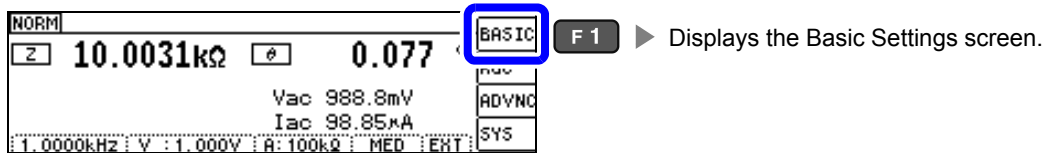

2 Select [TRIG].

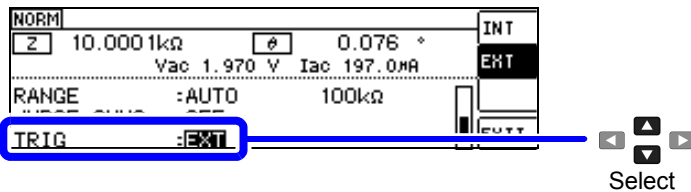

3 Set the trigger setting to [INT] or [EXT].



When [EXT] is selected

There are the following three types of input method for a trigger.

- Press **TRIG** key on the screen to manually input a trigger: Measurement is performed once.
- Input via EXT I/O: Measurement is performed once each time a negative logic pulse signal is applied.

See "Connector Type and Signal pin assignments" (p. 178)

- Input from interface: Measurement is performed once when \*TRG is transmitted.

See Communications commands in the included LCR Application Disk documentation

4

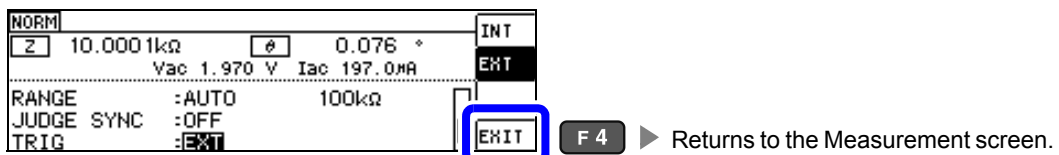



### 4.2.7 Setting Measurement Conditions for Individual Ranges

The measurement speed, averaging settings, trigger delay, and trigger synchronous output function can be configured for individual ranges. The same settings can also be used for all ranges. (p.60)

#### List screen layout

RANGE	SPEED	AVG	DELAY	SYNC	EDIT
100mΩ	FAST	OFF	0.0000s	OFF	
1Ω	MED	2	0.0010s	0.0010s	
10Ω	SLOW	10	0.0100s	0.0100s	
100Ω	SLOW2	100	0.1000s	0.1000s	EXIT

## 4.2 Setting Basic Settings of Measurement Conditions

### Selecting range settings to change

**1** Open the Basic Settings screen.

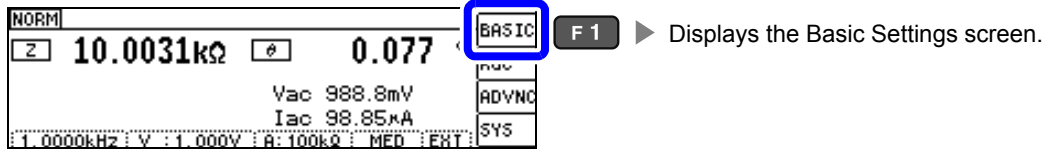

**2** Select [LIST].

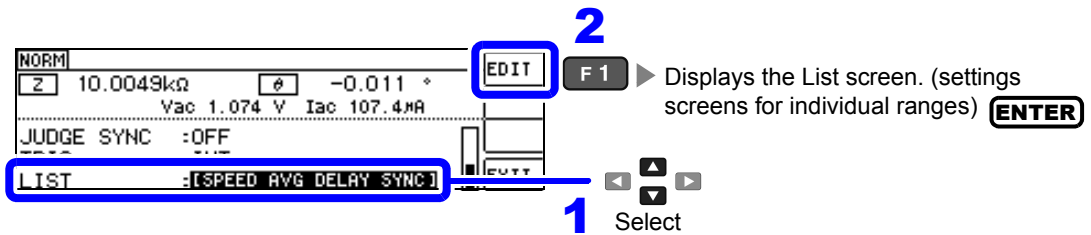

**3** Select the range setting you wish to change.

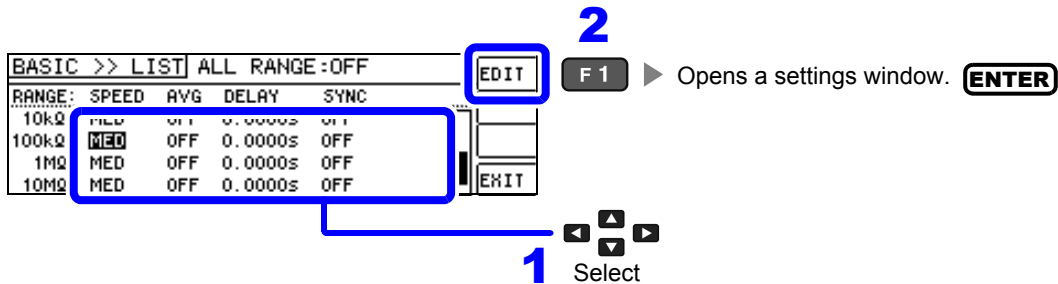

Setting	Description	Window
SPEED	Sets the measurement speed. (p.53)	
AVG	Sets the average. (p.54)	
DELAY	Sets the trigger delay. (p.56)	
SYNC	Sets the trigger synchronous output function. (p.57)	

Ranges that can be selected:  
 100 mΩ/1 Ω/10 Ω/100 Ω/1 kΩ/10 kΩ/100 kΩ/1 MΩ/10 MΩ/100 MΩ

## 4.2 Setting Basic Settings of Measurement Conditions

## Setting the Measurement speed

The testing speed can be set. The slower the testing speed is, the more accurate are the results.

- 1 Select the range speed you wish to change on the List screen.  
See "Selecting range settings to change" (p. 52)

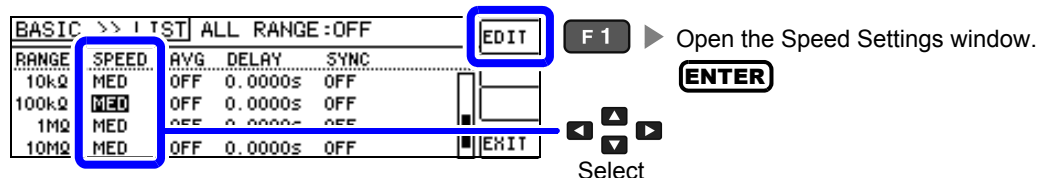

- 2 Set the SPEED.  
The measurement speed varies with the measurement conditions.  
See "11.3 About Measurement Times and Measurement Speed" (p.213)

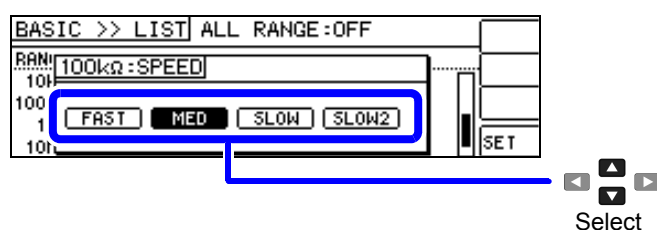

To select the measurement speed.

FAST	Performs high-speed measurement.
MED	This is the normal measurement speed.
SLOW	Measurement precision improves.
SLOW2	Measurement accuracy is better than SLOW.

3

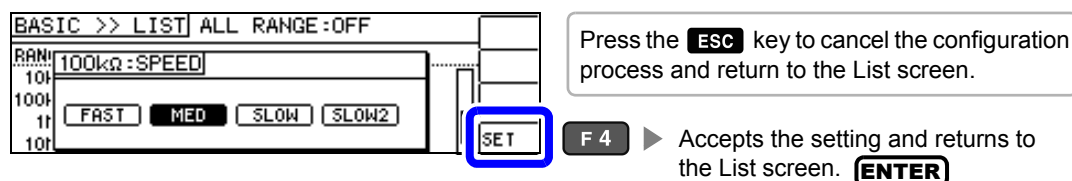
**NOTE**

- You can set the measurement speed at a greater level of detail with the waveform averaging function.
  - The speed cannot be set while the waveform averaging function is enabled.  
Disable the waveform averaging function before setting the speed.
- See "4.5.2 Setting the Detection Signal Waveform Averaging Count (Waveform Averaging Function)" (p.99)

## 4.2 Setting Basic Settings of Measurement Conditions

### Displaying Average Values (Average set)

With the averaging function, the measured values can be averaged. Using this function, it is possible to reduce fluctuations in the measured value display.

**With internal trigger**

A rolling average of the tested values over the set number of times for averaging is always calculated backwards from the present. When the sample to be tested is changed over, it takes a little time for a certain stabilization time period until the results is reliable.

**With external trigger**

An average of the test values is calculated over the set number of times for averaging forwards from when the trigger is input.

When the number of averaging times is 4, the number of measurements, measurement output points, and measurement value calculation method during output are as follows.

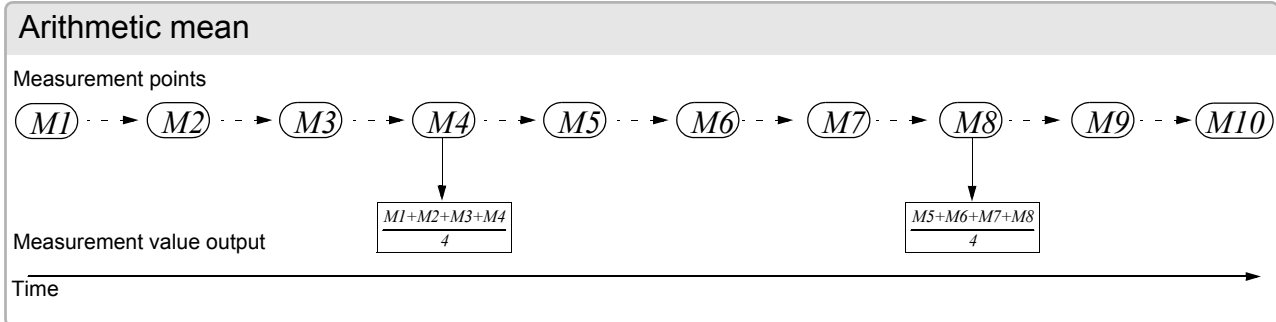
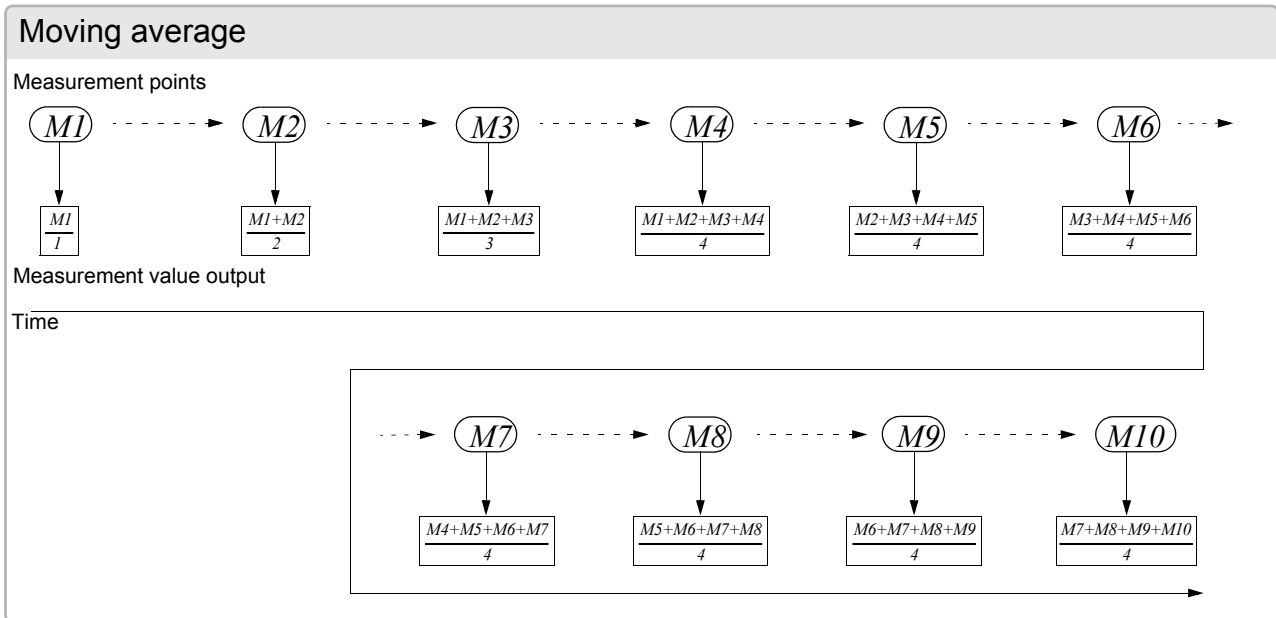

## 4.2 Setting Basic Settings of Measurement Conditions

- 1 On the List screen, select the range averaging count you wish to change.  
See "Selecting range settings to change" (p. 52)

**EDIT** F 1 ▶ Opens the Averaging Setting window.  
**ENTER**  
 Select

- 2 Set the averaging count. **DIGIT**  
Settable range: 1 to 256 times

**2**  
 F 1 ▶ Increases the value.  
 F 2 ▶ Decreases the value.  
 F 3 ▶ Reverts to the default value.  
**1** Select

**NOTE** You can also change the value with the **▲ ▼** keys.

- 3

Press the **ESC** key to cancel the configuration process and return to the List screen.  
 F 4 ▶ Accepts the setting and returns to the List screen. **ENTER**

## 4.2 Setting Basic Settings of Measurement Conditions

### Setting a delay before measurement data is acquired (trigger delay)

The delay time period from input of the trigger signal to measurement can be set. With this function it is possible to ensure that testing is started after the connection condition of the object being tested and the test cables has stabilized.

See "Trigger delays and the trigger synchronous output function" (p. 59)

- 1 On the List screen, select the range trigger delay you wish to change.  
See "Selecting range settings to change" (p. 52)

RANGE	SPEED	AVG	DELAY	SYNC
10kΩ	MED	OFF	0.0000s	OFF
100kΩ	MED	OFF	0.0000s	OFF
1MΩ	MED	OFF	0.0000s	OFF
10MΩ	MED	OFF	0.0000s	OFF

EDIT **F1** ▶ Opens the Trigger Delay Setting window.  
ENTER  
 ◀ ▶ Select

- 2 Set the delay time. **DIGIT**  
Settable range: 0 to 9.9999 s at 0.1 ms resolution

0.0000s  
↑ **F1** ▶ Increases the value.  
↓ **F2** ▶ Decreases the value.  
C **F3** ▶ Reverts to the default value.  
 ◀ ▶ Selects the digit to change.  
F4 Select

**NOTE** You can also change the value with the **↑** **↓** keys.

- 3 Press the **ESC** key to cancel the configuration process and return to the List screen.  
**SET** **F4** ▶ Accepts the setting and returns to the List screen. **ENTER**

SET **F4** ▶ Accepts the setting and returns to the List screen. **ENTER**  
 Press the **ESC** key to cancel the configuration process and return to the List screen.

## 4.2 Setting Basic Settings of Measurement Conditions

### Applying the signal to the sample during measurement only (Trigger Synchronous Output Function)

This functionality outputs the measurement signal after trigger input is received so that the signal is only applied to the sample during measurement. You can also set a delay time to ensure that data is acquired after the sample stabilizes.

Thus reducing the generation of heat in the sample and decreasing electrode wear.

See "Trigger delays and the trigger synchronous output function" (p. 59)

- 1 On the List screen, select the range trigger synchronous output function you wish to change.

See "Selecting range settings to change" (p. 52)

F1 **EDIT** ▶ Opens the Trigger Synchronous Output Function Setting window. **ENTER**

Select

- 2 Enable or disable the trigger synchronous output function.

F1 **OFF** ▶ Disables the trigger synchronous output function.

F2 **ON** ▶ Enables the trigger synchronous output function.

1 Select

- 3 Select and enter the wait time that will be allowed to elapse before measurement starts.

**DIGIT**

Settable range: 0.0010 to 9.9999 s

F1 **▲** ▶ Increases the value.

F2 **▼** ▶ Decreases the value.

F3 **C** ▶ Reverts to the default value.

1 Select

**NOTE**

You can also change the value with the **▲** **▼** keys.

- 4

F4 **SET** ▶ Accepts the setting and returns to the List screen. **ENTER**

Press the **ESC** key to cancel the configuration process and return to the List screen.

## 4.2 Setting Basic Settings of Measurement Conditions

---

**NOTE**

- When the trigger synchronous output function is set to ON, there is a measurement time delay because the instrument enters a wait time which spans from when the measurement signal is output to when data is acquired.
  - [See "11.3 About Measurement Times and Measurement Speed" \(p.213\)](#)
  - Changing the settings while the trigger synchronous output function is on may cause the set level to be momentarily output.
  - The measurement signal is output when the trigger signal is input and stops after measurement ends.
  - Setting the contact check timing to [\[BOTH\]](#) or [\[BEFORE\]](#) with the contact check function will automatically turn the trigger synchronous output function on. Set the amount of time to wait before starting measurement.
  - In continuous measurement mode, the measurement signal stops after measurement of the last panel ends.
-



Trigger delays and the trigger synchronous output function

Trigger delays provide functionality for setting a delay from the time that the trigger signal is input until measurement, while the trigger synchronous output function outputs the measurement signal during measurement only and additionally allows you to set a delay before data is acquired. The measurement process is as follows:

Trigger delay: ON; Trigger synchronous output: OFF

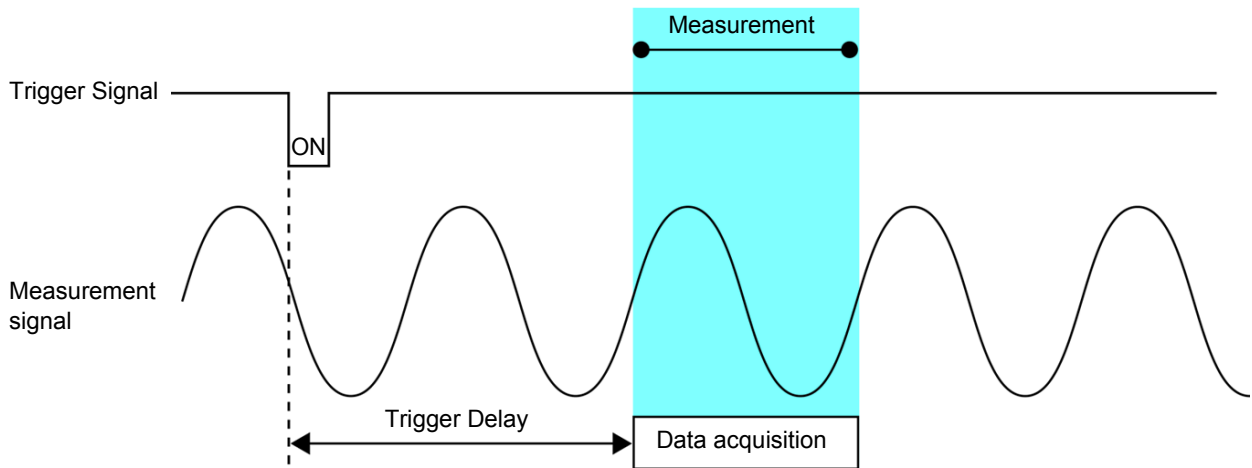

Trigger delay: ON; Trigger synchronous output: ON

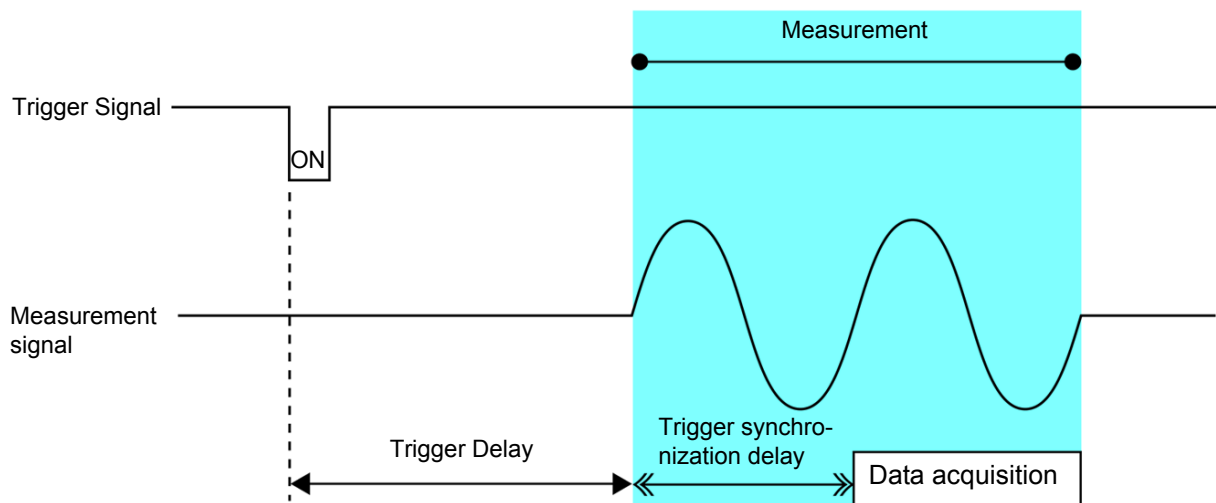

**NOTE** When the range synchronization function has been set, the range settings at which the trigger delay and trigger synchronous output function are enabled vary with the parameter settings.

Effective range settings differ according to the parameter settings for trigger delay and trigger synchronous output functions only.

Parameter	Range setting at which function is enabled
AC measurement only	AC measurement range
AC+DC measurement	AC measurement range
DC measurement only	DC measurement range

## 4.2 Setting Basic Settings of Measurement Conditions

### Applying settings to all ranges

To apply settings to all measurement ranges, configure function settings in their respective setting windows after turning on the ALL RANGE setting.

**NOTE** To configure settings for individual measurement ranges, turn off the ALL RANGE setting.

Select ALL RANGE and then select [ON] or [OFF].

**2**

F 1 ▶ Does not apply settings to all ranges.  
F 2 ▶ Applies settings to all ranges.

**1** Select

RANGE	SPEED	Avg	VELT	SLIM
100mΩ	FAST	OFF	0.0000s	OFF
1Ω	MED	2	0.0010s	0.0010s
10Ω	SLOW	10	0.0100s	0.0100s
100Ω	SLOW2	100	0.1000s	0.1000s

## 4.3 Setting DC Resistance Measurement

DC resistance measurement allows you to output a 2.0 V (fixed) DC signal to measure the DC resistance Rdc. The measurement process is as follows:

1. Measure the direct current resistance during 0 V application.
2. Measure the direct current resistance during 0 V application, and set it as the offset value.
3. Using the offset value, reduce measurement error.
4. Output the Rdc measurement value.

### NOTE

- It is necessary to set the line frequency for the power source being used by the instrument in order to reject noise. Set the frequency of the commercial power supply you are using before performing measurements. Failure to set the line frequency correctly will result in unstable measurement values.

See "4.3.4 Setting the Line Frequency" (p.70)

- To measure DC resistance, you need to set [Rdc] in the measurement parameters beforehand.

See "4.2.1 Setting Display Parameters" (p.31)

- When [Rdc] and other parameters are set, the DC resistance is measured after those other parameters have been measured with the AC signal. The measurement conditions can be set individually.

- When the sample is a capacitor, it may not be possible to perform DC resistance measurement accurately.

- The time required until the DC signal level stabilizes differs depending on the test sample to be measured. To ensure measurement is performed accurately, observe the measurement waveform in advance and then set the delay time required until the DC signal level stabilizes.

See "4.3.2 Setting a Delay Time for DC Measurement (DC Delay)" (p.67)

"4.3.3 Setting a Delay Time for Offset Measurement (Adjustment Delay)" (p.69)

### Adding Rdc to Measurement Parameters

- 1 Open the Basic Settings screen.

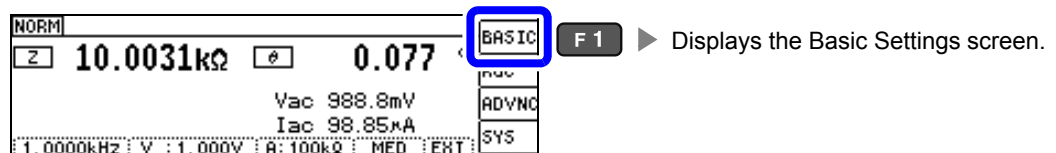

- 2 Select the parameter you wish to change.

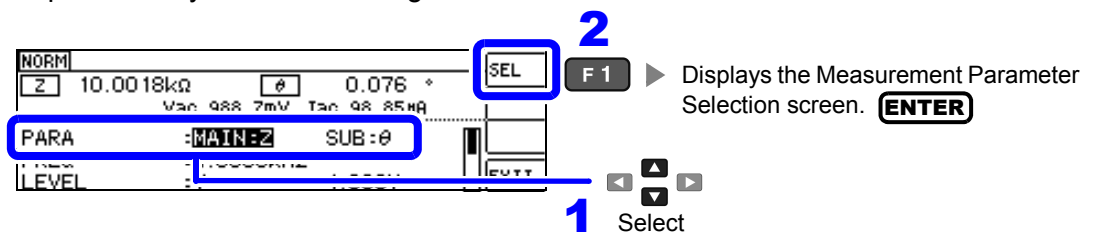

- 3 Set the parameter to [Rdc].

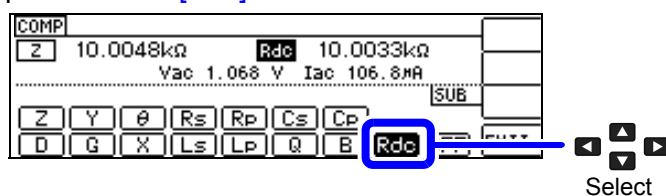

### 4.3 Setting DC Resistance Measurement

4

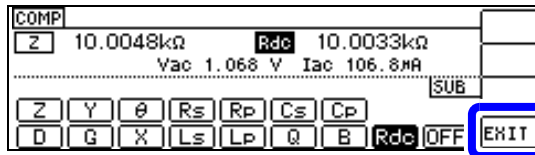

F 4

Accepts the selected parameter and returns to the Basic Settings screen.

**ENTER**

#### 4.3.1 Setting the Measurement Range

There are three methods for setting the measurement range: AUTO, HOLD, and JUDGE SYNC.

**AUTO**

The most suitable test range is set automatically. (Automatically sets the optimal measurement range when measuring samples whose impedance varies greatly with the frequency, or unknown samples.)

**HOLD**

Fixes the measurement range. The range is set manually. (Fixing the range allows high-speed measurement.)

**JUDGE SYNC**

Automatically sets the optimal range for the comparator and BIN measurement judgment standards. (Automatically sets the optimal range relative to the comparator and BIN measurement judgment standards when the sample's impedance varies greatly with the frequency.)

**NOTE** Using the HOLD or AUTO settings when the JUDGE SYNC setting is on causes the JUDGE SYNC setting to be automatically disabled.

## Setting AUTO Ranging

- 1 Open the Rdc Settings screen.



- 2 Select [RANGE].

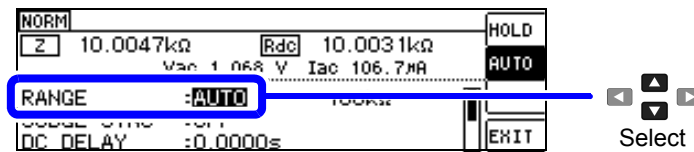

- 3 Set the measurement range to [AUTO].



Outside the accuracy guarantee range, AUTO ranging may not function properly, preventing a range from being selected. If this occurs, check the accuracy guarantee range in "11.2 Measurement Range and Accuracy" (p.206) and change the measurement conditions.

- 4

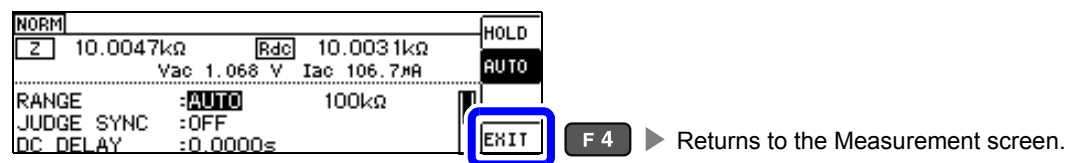

## AUTO range limit function

The AUTO range limit function allows you to limit the AUTO ranging range. The AUTO range limit function can be set using communications commands only. It cannot be set from the instrument.

See Communications commands in the included LCR Application Disk documentation  
(:DCResistance:RANGE:AUTO:LIMIT)

## 4.3 Setting DC Resistance Measurement

### Setting HOLD Ranging

**1** Open the Rdc Settings screen.

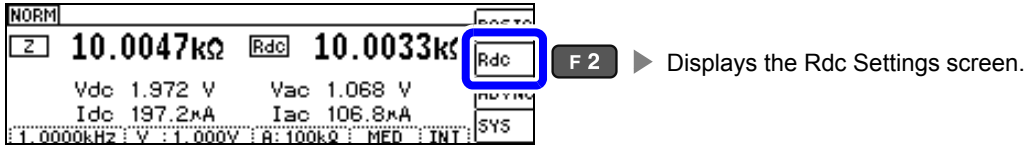

**2** Select [RANGE].

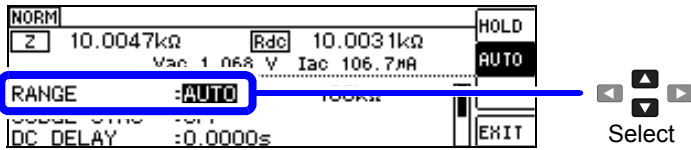

**3** Set the measurement range to [HOLD].

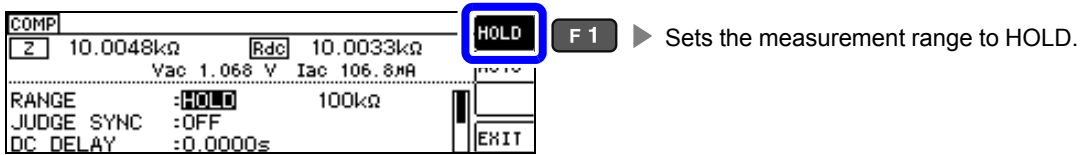

**4** To select the measurement range.

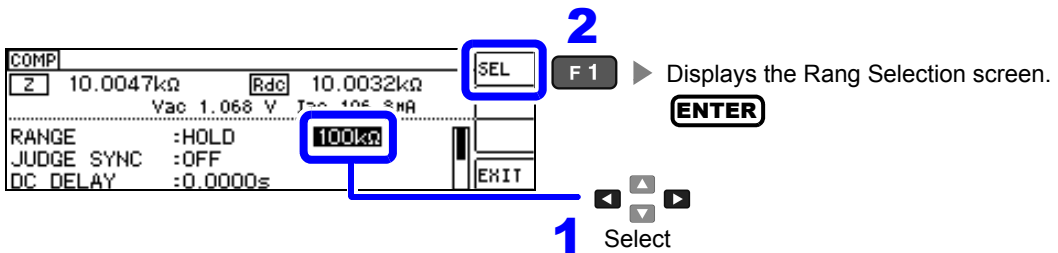

4.3 Setting DC Resistance Measurement

- 5** Set the measurement range.  
Set the measurement range according to the total impedance of the sample and measurement cable.

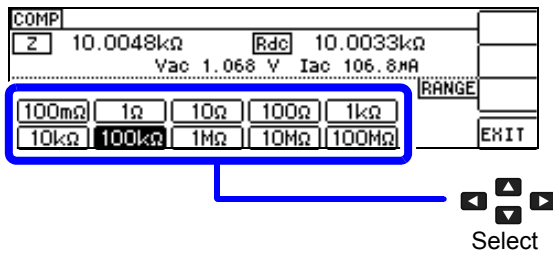

Range	Accuracy guaranteed range	AUTO Ranging Range
100 MΩ	8 MΩ to 200 MΩ	8 MΩ to
10 MΩ	800 kΩ to 100 MΩ	800 kΩ to 10 MΩ
1 MΩ	80 kΩ to 10 MΩ	80 kΩ to 1 MΩ
100 kΩ	8 kΩ to 1 MΩ	8 kΩ to 100 kΩ
10 kΩ	800 Ω to 100 kΩ	800 Ω to 10 kΩ
1 kΩ	80 Ω to 10 kΩ	80 Ω to 1 kΩ
100 Ω	8 Ω to 100 Ω	8 Ω to 100 Ω
10 Ω	800 mΩ to 10 Ω	800 mΩ to 10 Ω
1 Ω	80 mΩ to 1 Ω	80 mΩ to 1 Ω
100 mΩ	10 mΩ to 100 mΩ	0 Ω to 100 mΩ

**NOTE**

- The guaranteed accuracy range varies depending on the measurement conditions. See Check the guaranteed accuracy range as described in "11.2 Measurement Range and Accuracy" (p.206).
- Changing the measurement range while the AUTO setting is enabled automatically enables the HOLD setting.
- The measurement range is determined according to the test range setting. If the display for the measured value shows **OVERFLOW** or **UNDERFLOW**, that means that measurement cannot be performed using the currently set test range. Either you should set AUTO ranging so as to select the most suitable test range automatically, or you should set a more suitable test range manually. If a measurement result is outside the display range (p.201), **DISP OUT** is displayed.
- The accuracy guarantee range is defined in terms of uncorrected measurement values.

**6**

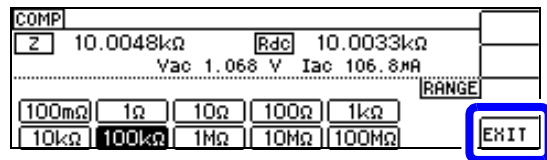

**F 4** ► Changes the selected range and returns to the Basic Settings screen.  
**ENTER**

**NOTE**

- The test range setting is made according to the combination of the impedances of the sample being tested and the test cables. Therefore it can happen that testing is not possible, if the test range is held with HOLD only upon the basis of the impedance of the sample under test. If this happens, you should change the test range, making reference to "6.1 Setting Open Circuit Compensation" (p.125) and "6.2 Short Circuit Compensation" (p.136).
- If the measurement value is outside the accuracy guarantee, the following comment will be displayed at the top of the screen.

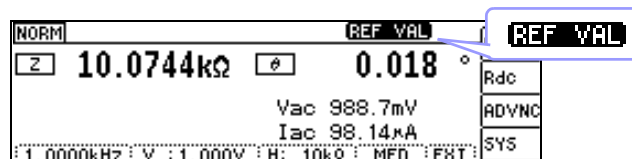

In this case, you should consider the following possible causes, and you should either change the test conditions while checking the accuracy assured ranges "11.2 Measurement Range and Accuracy" (p.206), or you should consider the measured values as values for reference.

- Perhaps the test signal level is too low, increase the test signal level.
- If the current measurement range (during HOLD setting) is not appropriate, set again in the AUTO range, or change the range by manual.

4.3 Setting DC Resistance Measurement

JUDGE SYNC setting

When the judgment synchronization setting is enabled and you wish to set an optimal range based on the comparator or BIN measurement judgment standards, it is not necessary to set the range using the HOLD setting.

**NOTE** This setting is only available when the judgment standards have been set for comparator and BIN measurement.(p.75)

When judgment standards have been set for comparator and BIN measurement with this setting on, the range will be automatically switched to the optimal range. However, the AUTO range is used when no judgment standards have been set.

1 Open the Rdc Settings screen.

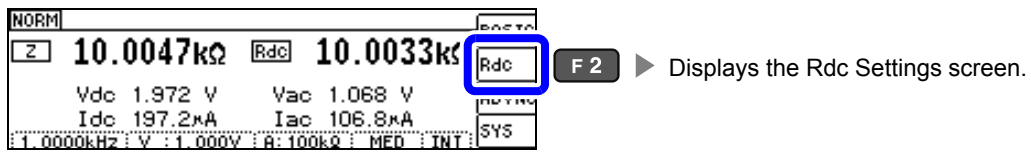

2 Select [JUDGE SYNC].

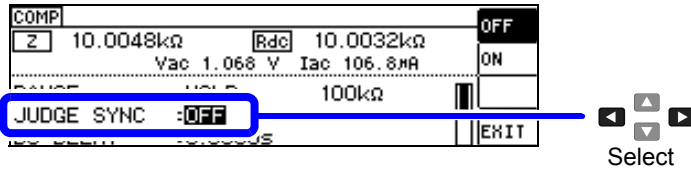

3 Turn the JUDG SYNC setting [OFF] or [ON].

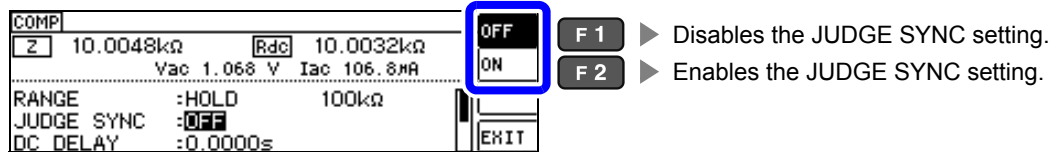

4

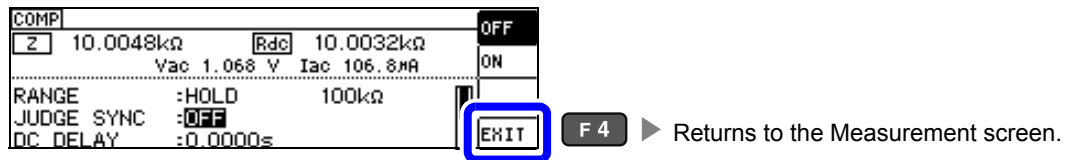

Parameter combination conditions for the JUDGE SYNC setting.

		SUB Parameter	
		OFF	Rdc
MAIN Parameter	OFF	×	●
	Rdc	●	●

×	Invalid setting (treated as AUTO range)
●	Valid setting



### 4.3.2 Setting a Delay Time for DC Measurement (DC Delay)

This section describes how to set a delay before DC resistance measurement is started, for example when switching to DC resistance measurement after measurement using an AC signal. The delay time delays measurement until the DC level stabilizes.

When number of averaging times is 1

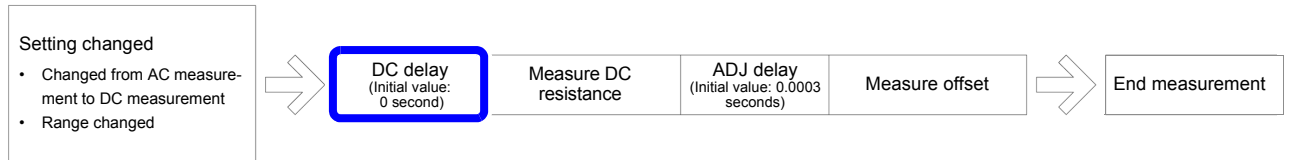

When the number of averaging times is 2 or more  
(The number of times is 2 in this example)

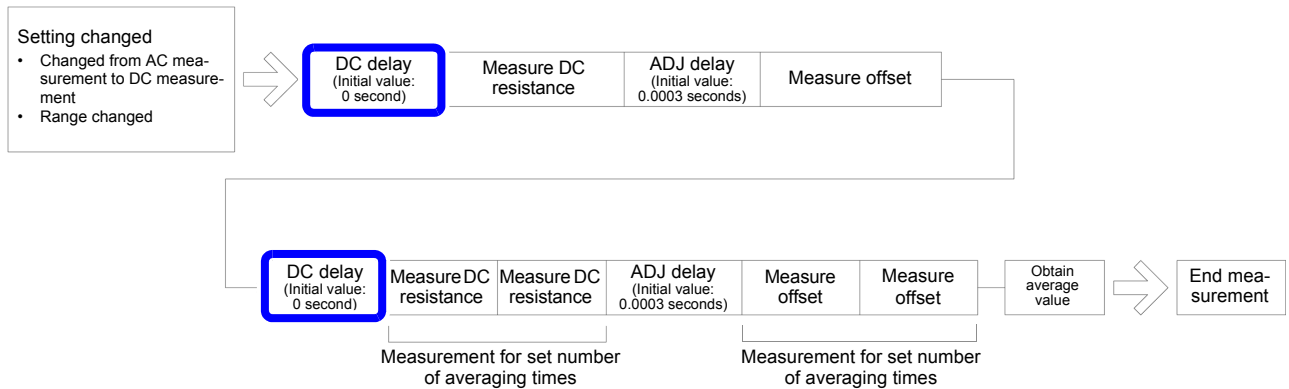

## 4.3 Setting DC Resistance Measurement

**1** Open the Rdc Settings screen.

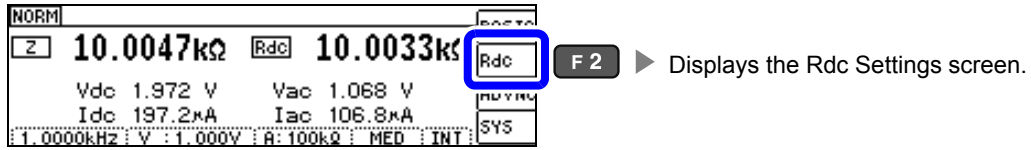

**2** Select [DC DELAY] and change the value. **DIGIT**  
 Settable range: 0 to 9.9999 s

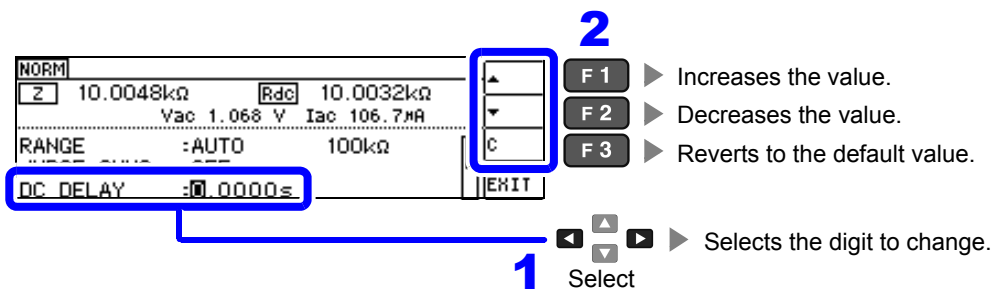

**3**

COMP	Z	10.0046kΩ	Rdc	10.0033kΩ
		Vac 1.068 V Iac 106.8mA		
RANGE		:HOLD	100kΩ	
JUDGE SYNC		:OFF		
DC DELAY		: 5.0000s		
EXIT				

F 4 ► Returns to the Measurement screen.

**NOTE** The time required until the DC signal level stabilizes differs depending on the test sample to be measured. To ensure measurement is performed accurately, observe the measurement waveform in advance and then set the delay time required until the DC signal level stabilizes.

### 4.3.3 Setting a Delay Time for Offset Measurement (Adjustment Delay)

The delay time delays measurement until offset measurement (DC 0V) stabilizes.

When number of averaging times is 1

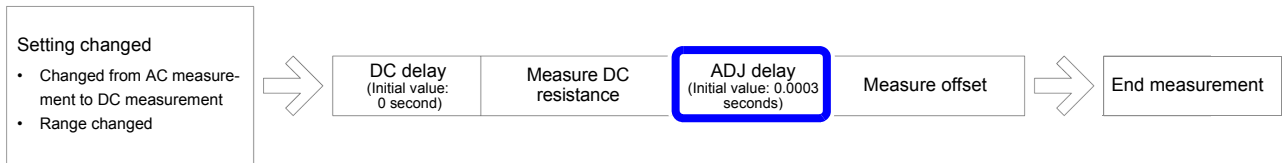

When the number of averaging times is 2 or more  
(The number of times is 2 in this example)

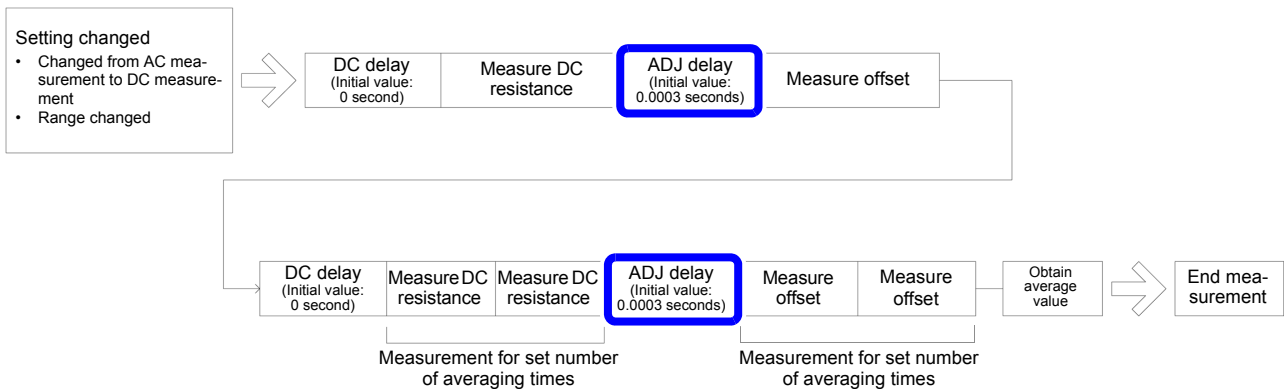

**1** Open the Rdc Settings screen.

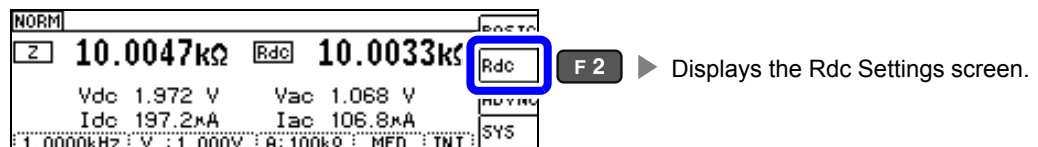

**2** Select [ADJ DELAY] and change the value. **[DIGIT]**  
Settable range: 0.0030 s to 9.9999 s

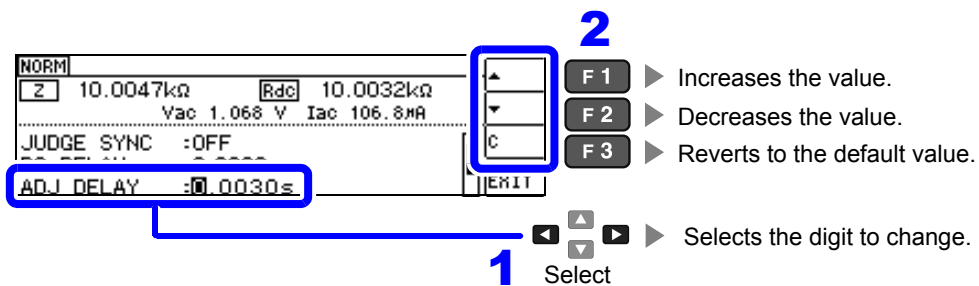

**3**

4.3 Setting DC Resistance Measurement

4.3.4 Setting the Line Frequency

When performing DC resistance measurement, be sure to set the line frequency of the power supply being used.

1 Open the Rdc Settings screen.

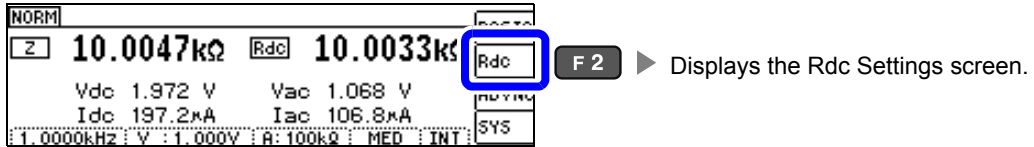

2 Select [LINE FREQ] and select the desired line frequency.

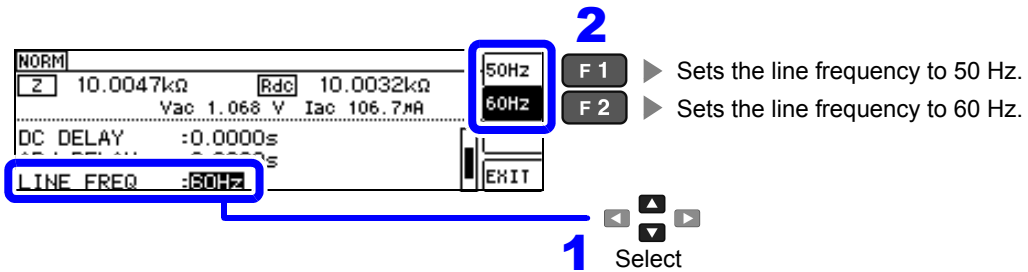

3

F 4 Returns to the Measurement screen.

**NOTE** It is necessary to set the line frequency for the power source being used by the instrument in order to reject noise. Set the frequency of the commercial power supply you are using before performing measurements. Failure to set the line frequency correctly will result in unstable measurement values.

### 4.3.5 Setting Measurement Conditions for Individual Ranges

The measurement speed and averaging settings can be configured for individual ranges. The same settings can also be applied to all ranges.

#### List screen layout

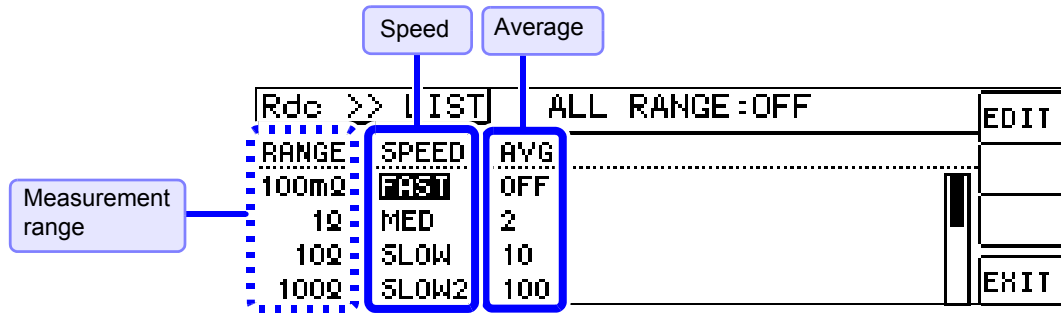

## 4.3 Setting DC Resistance Measurement

### Selecting the range setting you wish to change

**1** Open the Rdc Settings screen.

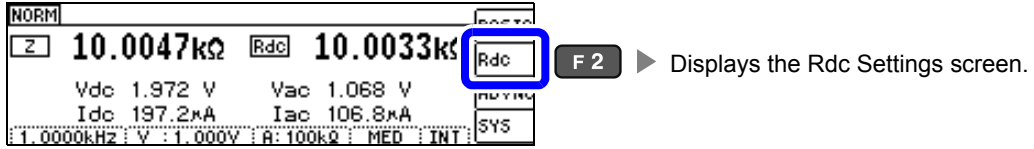

**2** Select [LIST].

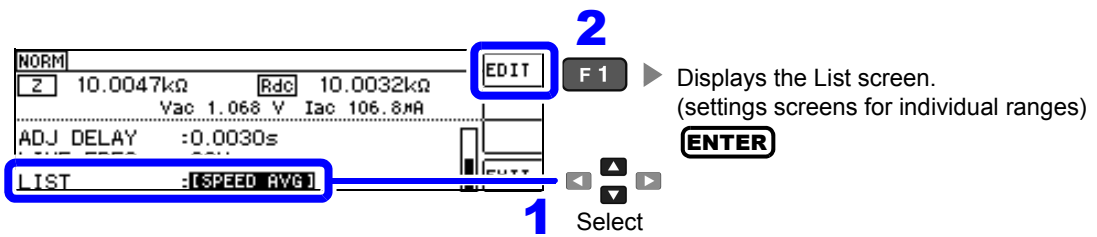

**3** Select the range setting you wish to change.

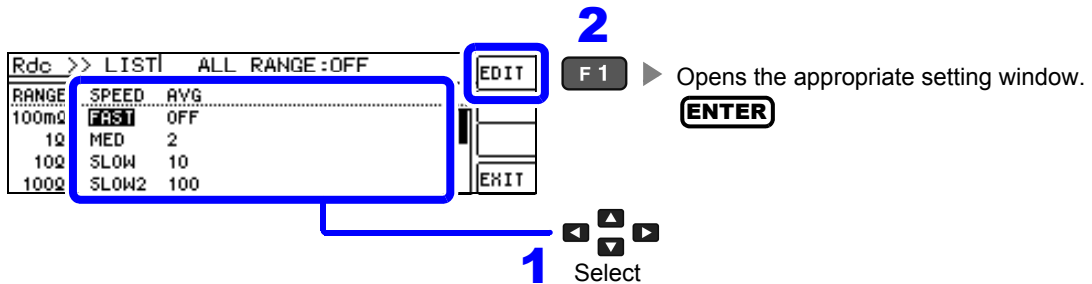

Setting	Description	Window
SPEED	Sets the measurement speed. (p.73)	
AVG	Configures averaging. (p.74)	

Ranges that can be selected:  
 100 mΩ/1 Ω/10 Ω/100 Ω/1 kΩ/10 kΩ/100 kΩ/1 MΩ/10 MΩ/100 MΩ

## Setting the measurement speed

The testing speed can be set. The slower the testing speed is, the more accurate are the results.

- 1 Select the range speed you wish to change on the Rdc screen.  
See "Selecting the range setting you wish to change" (p. 72)

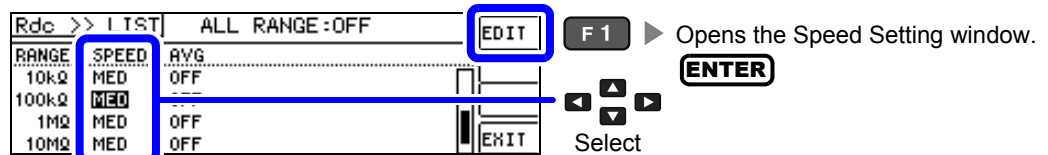

- 2 Set the [SPEED].  
The measurement speed varies with the measurement conditions.  
See "11.3 About Measurement Times and Measurement Speed" (p.213)

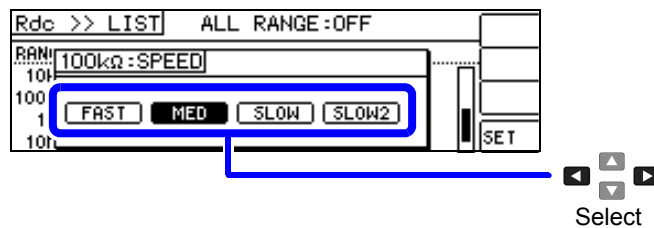

To select the measurement speed.	
FAST	Performs high-speed measurement.
MED	This is the normal measurement speed.
SLOW	Measurement precision improves.
SLOW2	Measurement accuracy is better than SLOW.

3

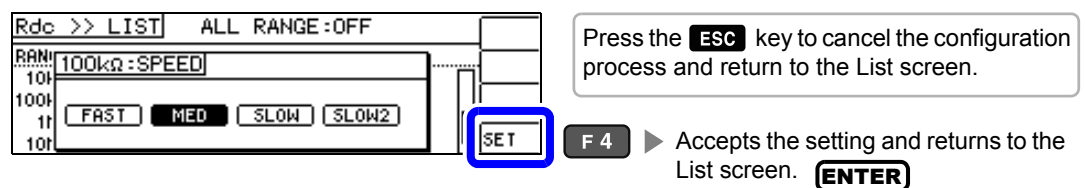

- NOTE**
- You can set the measurement speed at a greater level of detail with the waveform averaging function.
  - The speed cannot be set while the waveform averaging function is enabled. Disable the waveform averaging function before setting the speed.
- See "4.5.2 Setting the Detection Signal Waveform Averaging Count (Waveform Averaging Function)" (p.99)

## 4.3 Setting DC Resistance Measurement

### Displaying Average Values (Averaging Set)

With the averaging function, the measured values can be averaged. Using this function, it is possible to reduce fluctuations in the measured value display.

After setting the signal level and range, measurement is performed the number of times set with the averaging count, and the measurement value is displayed.

**NOTE** The averaging process during Rdc measurement performs arithmetic mean processing regardless of the trigger setting.(p.54)

- 1 Select the range averaging count you wish to change on the Rdc screen.  
See "Selecting the range setting you wish to change" (p. 72)

F 1 ▶ Opens the Averaging Setting window.

ENTER

Select

- 2 Set the averaging count. **DIGIT**  
Settable range: 1 to 256

F 1 ▶ Increases the value.

F 2 ▶ Decreases the value.

F 3 ▶ Reverts to the default value.

Select

1 Select

**NOTE** You can also change the value with the ▲ ▼ keys.

- 3

Press the **ESC** key to cancel the configuration process and return to the List screen.

F 4 ▶ Accepts the setting and returns to the List screen. **ENTER**

### Applying settings to all ranges

To apply settings to all measurement ranges, configure function settings in their respective setting windows after turning on the ALL RANGE setting.

**NOTE** To configure settings for individual measurement ranges, turn off the ALL RANGE setting.

Select ALL RANGE and then select ON or OFF.

F 1 ▶ Does not apply settings to all ranges.

F 2 ▶ Applies settings to all ranges.

1 Select



## 4.4 Judging Measurement Results

This function, which compares measurement results with a user-specified standard and displays a judgment result, is useful in applications such as quality evaluation. You can select from comparator measurement, in which measurement values are compared to a single judgment standard, and BIN measurement, in which measurement values are compared to multiple reference standards (up to 10).

### Setting the judgment mode

- 1 Open the Advanced Settings screen.



- 2 Select [JUDGE] and set the judgment mode.

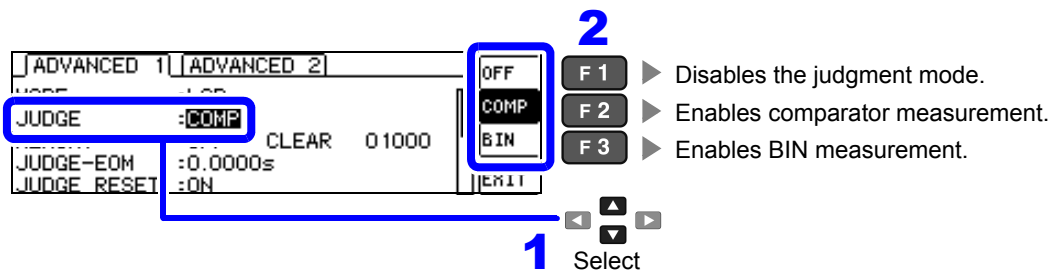

- 3

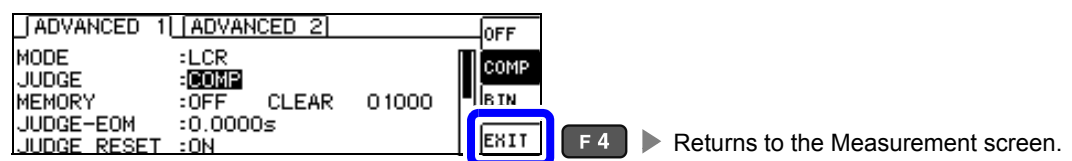

## 4.4 Judging Measurement Results

### 4.4.1 Making Judgments Based on Upper and Lower Limit Values (Comparator Measurement Mode)

The comparator measurement allows you to do the following.

- Preset a reference value and upper and lower limit values as the judgment reference, and display a judgment result as HI (higher than the upper limit value), IN (within the range set for the upper and lower limit values), or LO (lower than the lower limit value).
  - Output the judgment results to an external device (via the EXT I/O connector).
  - Select different settings and perform judgment for up to two parameters.
  - Be notified of judgment results by buzzer.
- See** "4.5.12 Disabling Key Operation (Key-lock Function)" (p.114)
- Judgment results can be checked using the judgment results indicator LED on the front of the instrument.
- See** "COMP indicator LEDs" (p. 10)

(Front panel LEDs)

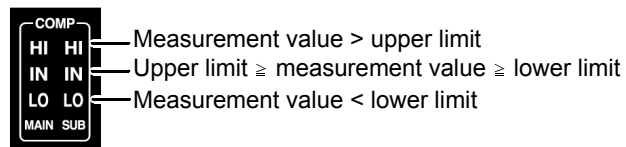

When the comparator measurement results for the main and sub parameters are IN, the IN indicator turns green. When they are HI or LO, the HI or LO indicator turns red.

The comparator decision mode can be set as one of the following:

#### Absolute value (ABS) setting(p.78)

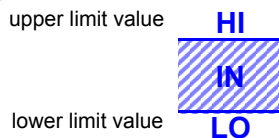

Set absolute values for the upper limit and lower limit values of the measurement parameters.  
The measurement values displayed are the same as those of the measurement parameters.

#### Percent (%) Setting(p.79)

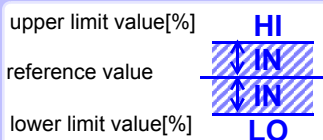

Enter reference values and then set percentages corresponding to the reference values as the upper limit and lower limit values\*<sup>1</sup>.  
The measurement values displayed are the same as those of the measurement parameters.

#### Deviation Percent (Δ%) Setting\*<sup>2</sup>(p.81)

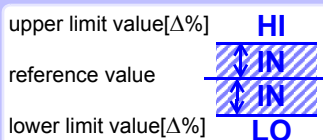

Enter reference values and then set percentages corresponding to the reference values as the upper limit and lower limit values\*<sup>1</sup>.  
The measurement values are displayed in deviations (Δ%) from the reference value.

\*1: The following equation is used to calculate the comparison upper limit value and comparison lower limit value.(In the case of the comparison lower limit value, if a value that is lower than the reference value is set, the minus (-) sign is required for the percentage setting value.)

$$\text{Upper limit comparison value(Lower limit comparison value)} = \text{reference value} + |\text{reference value}| \times \frac{\text{Percentage set value}}{100}$$

\*2: The following equation is used to calculate the Δ% value.

$$\Delta\% = \frac{\text{measurement value} - \text{reference value}}{|\text{reference value}|} \times 100$$

## 4.4 Judging Measurement Results

### **NOTE**

- The comparator judgment is made in the following order.
  - If the measurement value is "OVER FLOW", **HI** is displayed.  
(However, LO is displayed when the parameters are Y, Cs, Cp, G, and B.)  
If the measurement value is "UNDER FLOW", **LO** is displayed.  
(However, HI is displayed when the parameters are Y, Cs, Cp, G, and B.)  
If the measurement value is "SAMPLE ERR" or "CONTACT ERROR," **HI** is displayed.
  - Whether the measurement value is higher than the lower limit value is judged, and **LO** is displayed if the judgment is NG.
  - Whether the measurement value is lower than the upper limit value is judged, and **HI** is displayed if the judgment is NG.
  - If other than 1, 2, or 3, **IN** is displayed.

**No test is performed to ensure that the upper limit value is greater than the lower limit value, so no error message will be displayed if you set the upper limit value and lower limit value the wrong way around.**

- If the power is turned off while the comparator measurement screen is displayed, the comparator measurement screen will be displayed when the instrument starts the next time you turn the power on.
- Comparator measurement can be performed after setting either the upper or lower limit.

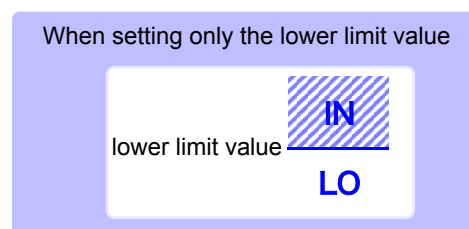
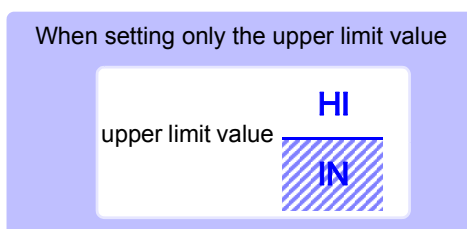

4.4 Judging Measurement Results

**1** Setting the Upper or Lower Limit Value as an Absolute Value (ABS) (Absolute Value mode)

**NOTE** Set the judgment mode to [COMP].  
See "Setting the judgment mode" (p. 75)

**1** Press **COMP / BIN** key.

**2** Select the parameter you wish to set to absolute value mode.

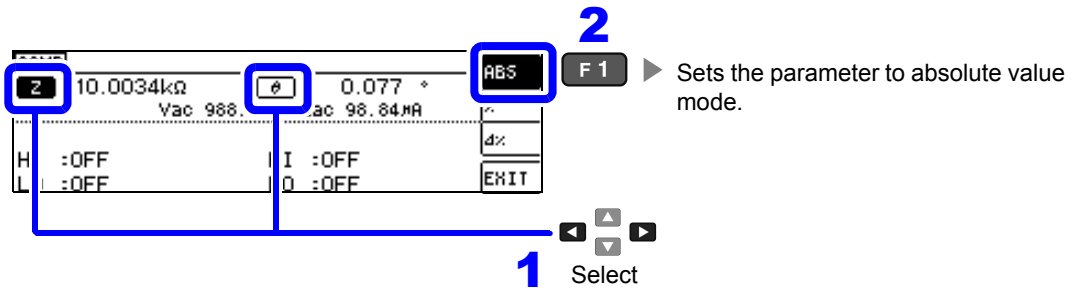

**3** Select the main or sub parameter value you wish to set.

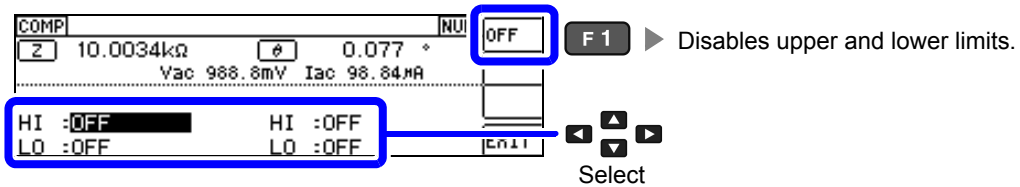

**4** Enter a value with the tenkey and accept it with the **ENTER** key. **10KEY**  
Settable range: -9.99999 G to 9.99999 G

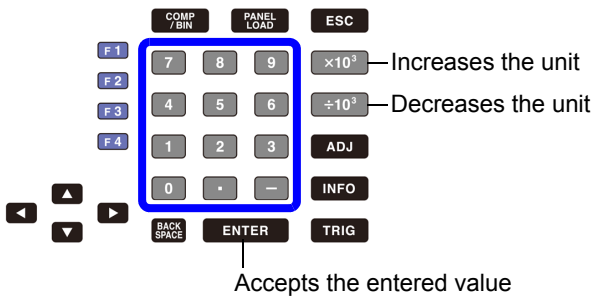

Unit:  
(a/f/p/n/μ/m/none/k/M/G)

If you make a mistake:  
Press **BACK SPACE** key and reenter the value.

**5**

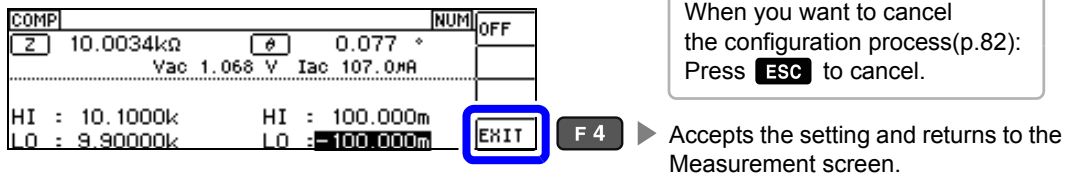

**2** Setting the Upper or Lower Limit Value as a Percentage (%) Relative to a Reference Value (Percentage mode)

You can also set upper and lower limit values as a percentage of a reference value.

**NOTE**

- Set the judgment mode to [COMP]. See "Setting the judgment mode" (p. 75)
- The reference value and upper and lower limit values are used in both percentage mode and deviation percentage mode.

**1** Press **COMP /BIN** key.

**2** Select the parameter you wish to set to percentage mode.

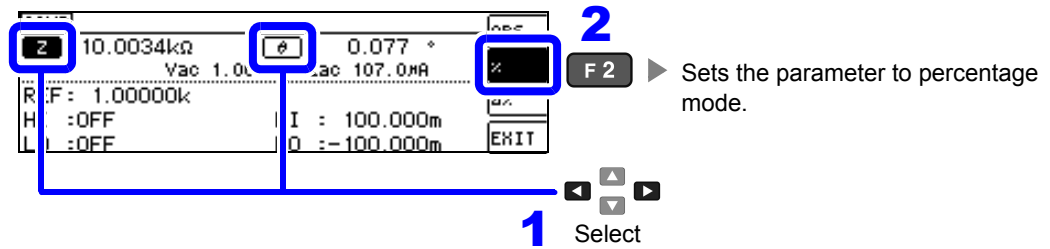

**3** Select the main and sub parameter reference values.

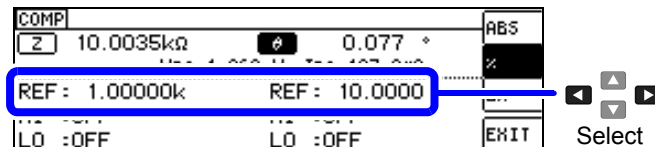

**4** Enter a value with the tenkey and accept it with the **ENTER** key. **10KEY**  
Settable range: -9.99999 G to 9.99999 G

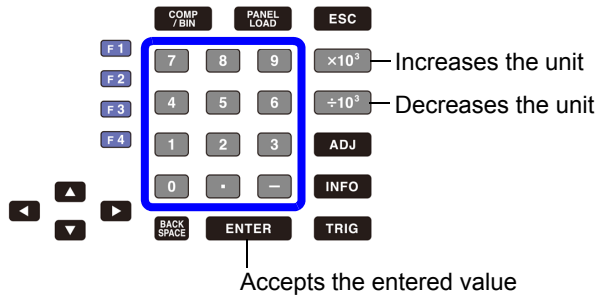

Unit:  
(a/f/p/n/μ/m/none/k/M/G)

If you make a mistake:  
Press **BACK SPACE** key and reenter the value.

4.4 Judging Measurement Results

5 Set the main and sub parameter upper and lower limit values.

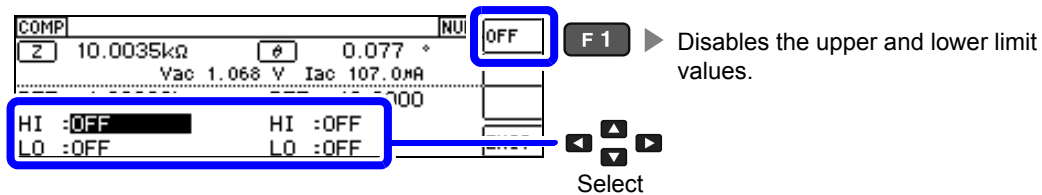

6 Enter a value with the tenkey and accept it with the **ENTER** key. **10KEY**  
 Settable range: -9.99999 G to 9.99999 G

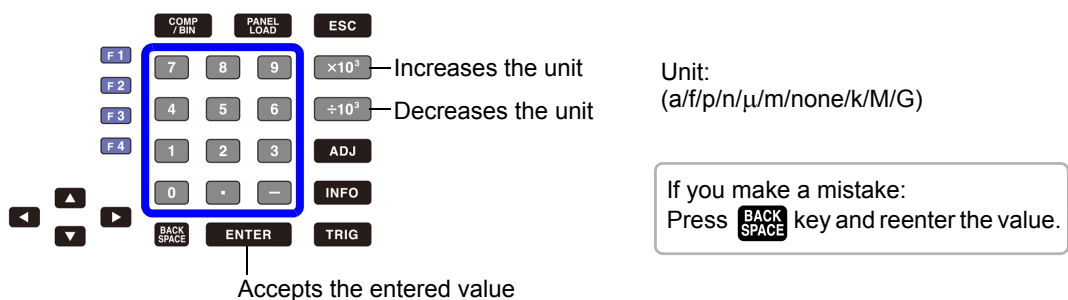

Upper limit value

- The upper limit value is set as a percentage of the reference value.
- In terms of the instrument's actual internal operation, the upper limit comparison value is calculated using the following equation and compared with the measurement value to make a judgment.

$$\text{Upper limit comparison value} = \text{reference value} + |\text{reference value}| \times \frac{\text{Percentage set value}}{100}$$

Lower limit value

- The lower limit value is set as a percentage of the reference value.
- In terms of the instrument's actual internal operation, the lower limit comparison value is calculated using the following equation. To set a value that is less than the measurement value, it is necessary to enter a negative percentage.

$$\text{Lower limit comparison value} = \text{reference value} + |\text{reference value}| \times \frac{\text{Percentage set value}}{100}$$

7

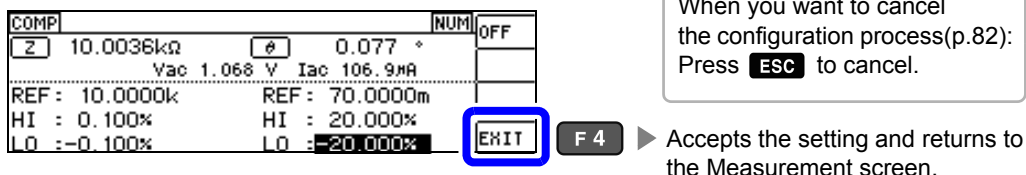

**3** Setting Upper and Lower Limit Values as ( $\Delta\%$ )Values Relative to the Offset from the Reference Value(Deviation Percentage Mode)

The upper and lower limit values can be set as a percentage based on the reference value, and the amount of deviation from the reference value can be displayed as the measurement value in the form of a percentage.

**NOTE** Set the judgment mode to [COMP].

See "Setting the judgment mode" (p. 75)

- In deviation percentage mode, the amount of deviation ( $\Delta\%$ ) from the reference value is displayed as the measurement value.
- The reference value and upper and lower limit values are used in both percentage mode and deviation percentage mode.

See " Setting the Upper or Lower Limit Value as a Percentage (%) Relative to a Reference Value (Percentage mode)" (p.79)

- The  $\Delta\%$  value is calculated using the following equation:

$$\Delta\% = \frac{\text{measurement value}-\text{reference value}}{|\text{reference value}|} \times 100$$

**1** Press **COMP/BIN** key.

**2** Select the parameter you wish to set to deviation percentage mode.

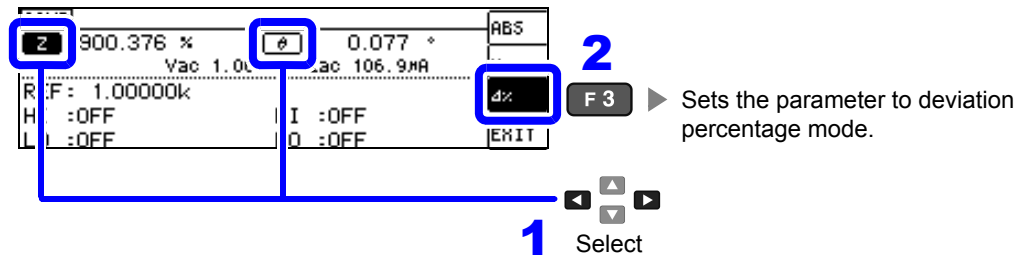

**3** Select the main and sub parameter reference values.

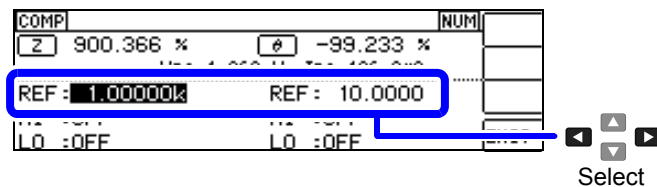

### 4.4 Judging Measurement Results

**4** Enter a value with the tenkey and accept it with the **ENTER** key. **10KEY**  
Settable range: -9.99999 G to 9.99999 G

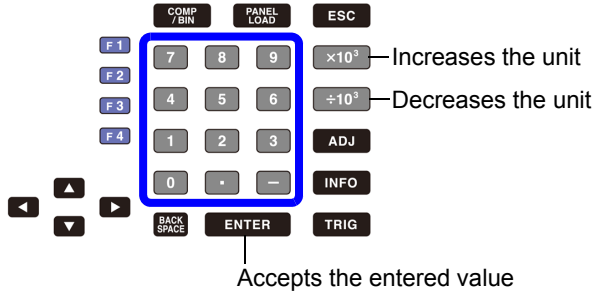

Unit:  
(a/f/p/n/ $\mu$ /m/none/k/M/G)

If you make a mistake:  
Press **BACK SPACE** key and reenter the value.

**5** Set the main and sub parameter upper and lower limit values.

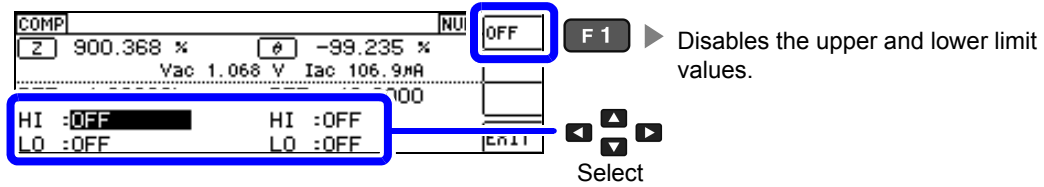

**6** Enter a value with the tenkey and accept it with the **ENTER** key. **10KEY**  
Settable range: -9.99999 G to 9.99999 G

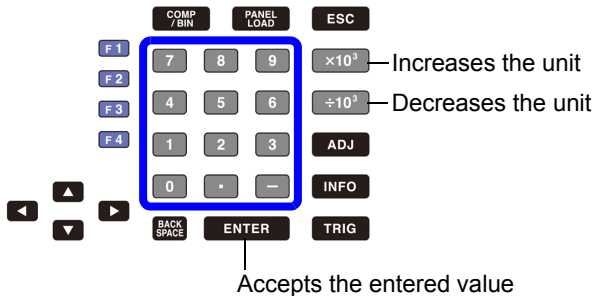

Unit:  
(a/f/p/n/ $\mu$ /m/none/k/M/G)

If you make a mistake:  
Press **BACK SPACE** key and reenter the value.

**7**

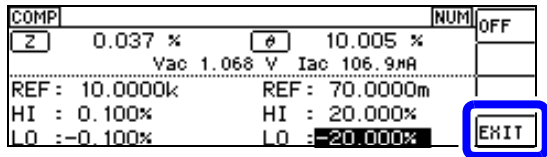

When you want to cancel the configuration process(p.82):  
Press **ESC** to cancel.

Accepts the setting and returns to the Measurement screen.

### When you want to cancel the comparator measurement setting:

When you want to cancel the comparator measurement setting, you can press **ESC** .

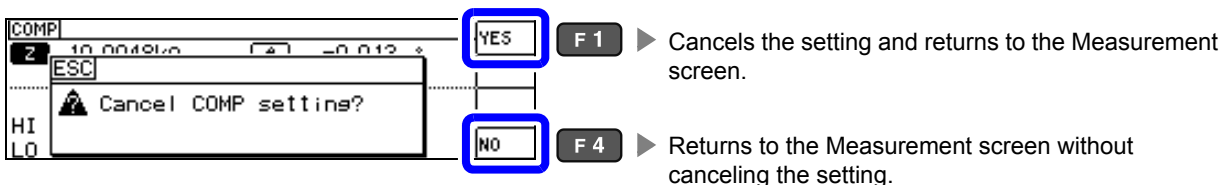



### 4.4.2 Classifying Measurement Results (BIN Measurement Function)

Up to 10 pairs of upper and lower limit values can be set for the main parameter, and judgment results are displayed based on these values. Only one pair of upper and lower limit values can be set for the sub parameter. Judgment results are output externally.

After selecting the BIN measurement judgment mode, set the judgment conditions. (p.75)

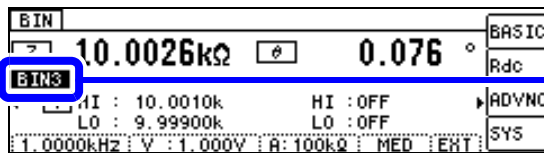

<b>BINS</b>	BIN judgment.
<b>---</b>	<ul style="list-style-type: none"> <li>When the main parameter is off.</li> <li>When BIN judgment has not been selected.</li> </ul>
<b>OUT</b>	When the main parameter value did not match any BIN.
<b>SUBNG</b>	When the main parameter value matched a BIN, but the sub parameter value did not.

- Be notified of judgment results by buzzer.  
See "4.5.10 Setting Operation Sounds (Beep Sounds)" (p.110)
- Judgment results can be checked using the judgment results indicator LED on the front of the instrument.  
See "COMP indicator LEDs" (p. 10)

<b>BINS</b>	<b>OUT</b>	<b>SUBNG</b>	<b>SUBNG</b>
Results = BIN judgment		Measurement value > upper limit for sub parameter	Measurement value < lower limit for sub parameter

4.4 Judging Measurement Results

About BIN function

Perform judgment in the order of BIN1 to BIN10. The BIN number for when a measurement value is first judged to be within the set judgment reference is displayed.

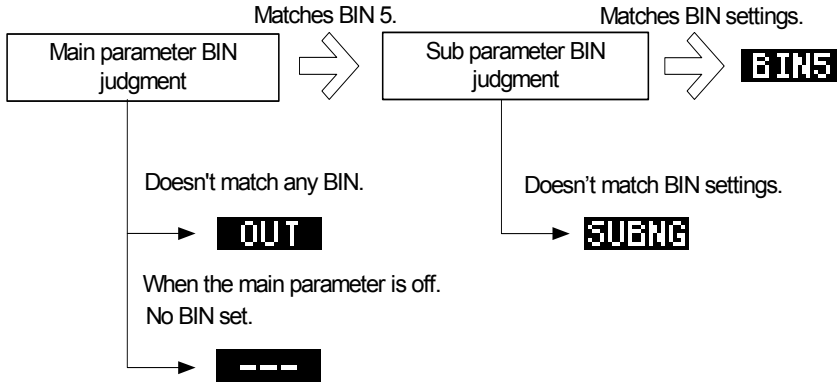

BIN judgment, main measurement value

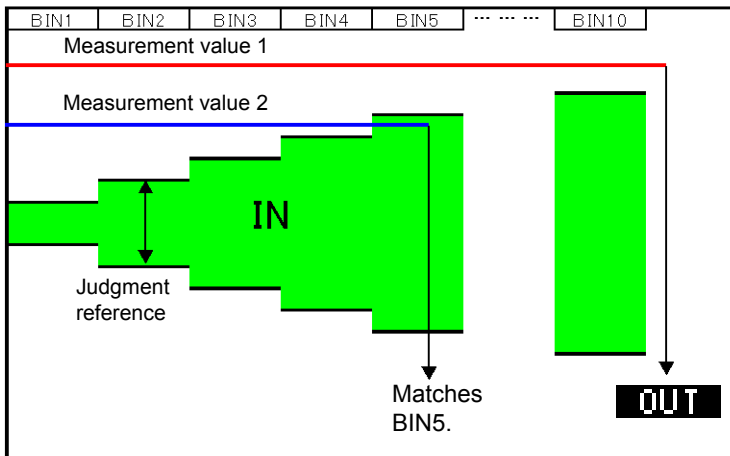

BIN judgment, sub measurement value

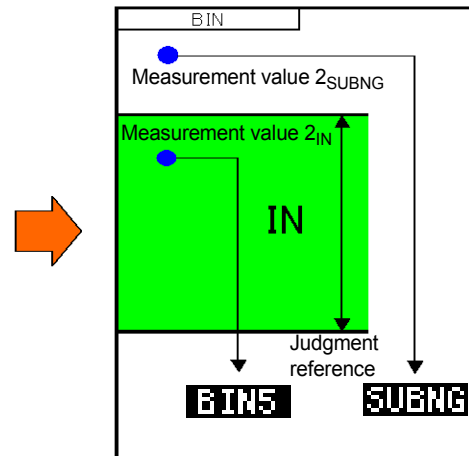

In BIN judgment, a judgment is made based on the main measurement value first, and then the result of a judgment using the sub measurement value is output. In the above example, **OUT** is displayed since main measurement value 1 did not fulfill any of the set judgment standards. Main measurement value 2 was the first to fulfill the standard, and **SUBNG** is displayed since the judgment standard set for BIN5 was fulfilled.

Next, BIN judgment is applied to the sub measurement values. Sub measurement value 2<sub>SUBNG</sub> did not fulfill the judgment standards, so **BIN5** is displayed. Sub measurement value 2<sub>IN</sub> fulfilled the judgment standards, so BIN5 is output.

**NOTE** By setting a series of increasingly lenient judgment standards as shown in the above diagram, you can rank (sort) measurement elements.

**4.4 Judging Measurement Results**

The following three judgment methods are available:

<div style="border: 1px solid #ccc; background-color: #e6f2ff; padding: 10px; margin-bottom: 10px;"> <p><b>Absolute value (ABS) setting(p.86)</b></p> <div style="border: 1px solid #ccc; background-color: white; padding: 5px; margin-top: 5px;"> <p>upper limit value <span style="float: right; border: 1px solid blue; background-color: #e6f2ff; padding: 2px;">HI</span></p> <div style="border: 1px solid blue; background-color: #e6f2ff; padding: 2px; margin: 2px 0;">IN</div> <p>lower limit value <span style="float: right; border: 1px solid blue; background-color: #e6f2ff; padding: 2px;">LO</span></p> </div> </div>	▶	<p>Set absolute values for the upper limit and lower limit values of the measurement parameters. The measurement values displayed are the same as those of the measurement parameters.</p>
<div style="border: 1px solid #ccc; background-color: #e6f2ff; padding: 10px; margin-bottom: 10px;"> <p><b>Percent (%) Setting(p.88)</b></p> <div style="border: 1px solid #ccc; background-color: white; padding: 5px; margin-top: 5px;"> <p>upper limit value[%] <span style="float: right; border: 1px solid blue; background-color: #e6f2ff; padding: 2px;">HI</span></p> <div style="border: 1px solid blue; background-color: #e6f2ff; padding: 2px; margin: 2px 0;">↑ IN ↓</div> <p>reference value <span style="float: right; border: 1px solid blue; background-color: #e6f2ff; padding: 2px;">IN</span></p> <div style="border: 1px solid blue; background-color: #e6f2ff; padding: 2px; margin: 2px 0;">↓ IN ↓</div> <p>lower limit value[%] <span style="float: right; border: 1px solid blue; background-color: #e6f2ff; padding: 2px;">LO</span></p> </div> </div>	▶	<p>Enter reference values and then set percentages corresponding to the reference values as the upper limit and lower limit values*<sup>1</sup>. The measurement values displayed are the same as those of the measurement parameters.</p>
<div style="border: 1px solid #ccc; background-color: #e6f2ff; padding: 10px; margin-bottom: 10px;"> <p><b>Deviation Percent (Δ%)*<sup>2</sup> Setting(p.92)</b></p> <div style="border: 1px solid #ccc; background-color: white; padding: 5px; margin-top: 5px;"> <p>upper limit value[Δ%] <span style="float: right; border: 1px solid blue; background-color: #e6f2ff; padding: 2px;">HI</span></p> <div style="border: 1px solid blue; background-color: #e6f2ff; padding: 2px; margin: 2px 0;">↑ IN ↓</div> <p>reference value <span style="float: right; border: 1px solid blue; background-color: #e6f2ff; padding: 2px;">IN</span></p> <div style="border: 1px solid blue; background-color: #e6f2ff; padding: 2px; margin: 2px 0;">↓ IN ↓</div> <p>lower limit value[Δ%] <span style="float: right; border: 1px solid blue; background-color: #e6f2ff; padding: 2px;">LO</span></p> </div> </div>	▶	<p>Enter reference values and then set percentages corresponding to the reference values as the upper limit and lower limit values*<sup>1</sup>. The measurement values are displayed in deviations (Δ%) from the reference value.</p>

\*1: The following equation is used to calculate the comparison upper limit value and comparison lower limit value. (In the case of the comparison lower limit value, if a value that is lower than the reference value is set, the minus (-) sign is required for the percentage setting value.)

$$\text{Upper limit comparison value(Lower limit comparison value)} = \text{reference value} + |\text{reference value}| \times \frac{\text{Percentage set value}}{100}$$

\*2: The following equation is used to calculate the Δ% value.

$$\Delta\% = \frac{\text{measurement value} - \text{reference value}}{|\text{reference value}|} \times 100$$

- NOTE**
- HI/IN/LO judgment procedure(p.76)
  - If the power is turned off in BIN measurement mode, the mode will be BIN measurement mode when the instrument starts the next time you turn the power on.
  - For a BIN number that does not require a BIN judgment, set the upper and lower limit values to OFF.
  - The measurement conditions that are used when normal measurement is performed are inherited as is for the measurement conditions when BIN is performed.
  - BIN measurement can be performed after setting either the upper or lower limit value.

When setting only the upper limit value

upper limit value HI

IN

When setting only the lower limit value

lower limit value LO

IN

4.4 Judging Measurement Results

**1** Setting the Upper or Lower Limit Value as an Absolute Value (ABS) (Absolute Value mode)

**NOTE** Set the judgment mode to [BIN].  
 See "Setting the judgment mode" (p. 75)

Main parameter settings

**1** Press **COMP / BIN** key.

**2** Select the [MAIN] parameter.

**2** **F 1** ▶ Selects the main parameter.

**1** Select

**3** Select [ABS].

**F 1** ▶ Selects absolute value mode.

Select

**4** Select the BIN number and select the upper and lower limit values.

**F 1** ▶ Does not set an upper or lower limit value.

Select

**5** Enter a value with the tenkey and accept it with the **ENTER** key. **10KEY**  
 Settable range: -9.99999 G to 9.99999 G

**COMP / BIN** **PANEL LOAD** **ESC**

**F 1** **F 2** **F 3** **F 4**

**x10<sup>3</sup>** — Increases the unit

**÷10<sup>3</sup>** — Decreases the unit

**ADJ** **INFO** **TRIG**

**Accepts the entered value**

Unit:  
 (a/f/p/n/μ/m/none/k/M/G)

If you make a mistake:  
 Press **BACK SPACE** key and reenter the value.

## Sub parameter settings

- 1** Select the sub parameter.

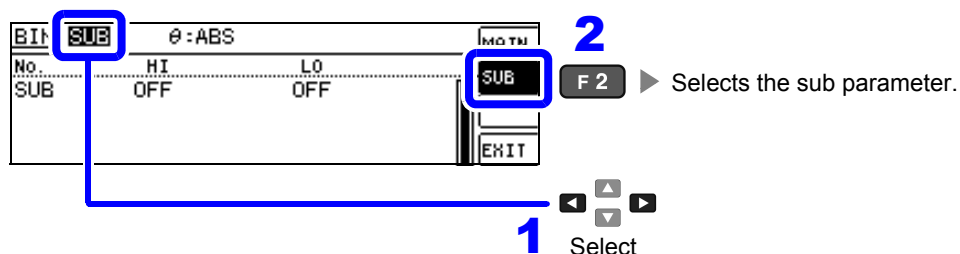

- 2** Select [ABS].

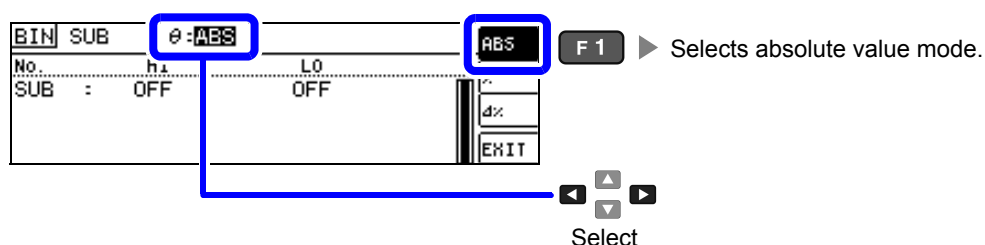

- 3** Select the sub parameter upper and lower limit values.

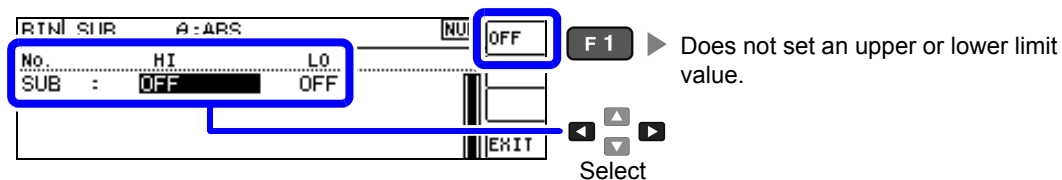

- 4** Enter a value with the tenkey and accept it with the **ENTER** key. **10KEY**  
Settable range: -9.99999 G to 9.99999 G

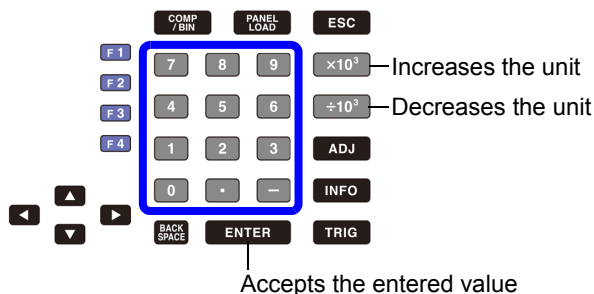

Unit:  
(a/f/p/n/μ/m/none/k/M/G)

If you make a mistake:  
Press **BACK SPACE** key and reenter the value.

- 5**

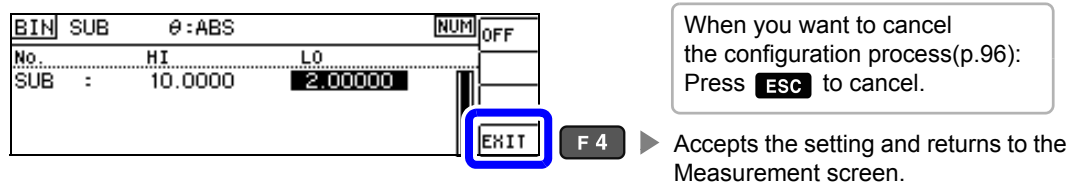

When you want to cancel  
the configuration process(p.96):  
Press **ESC** to cancel.

4.4 Judging Measurement Results

**2** Setting the Upper or Lower Limit Value as a Percentage (%) Relative to a Reference Value (Percentage mode)

You can also set upper and lower limit values as a percentage of a reference value.

- NOTE**
- Set the judgment mode to [BIN].
  - See "Setting the judgment mode" (p. 75)
  - The reference value and upper and lower limit values are used by both percentage mode and deviation percentage mode.

Main parameter settings

**1** Press **COMP/BIN** key.

**2** Select [MAIN].

BIN	MAIN	Z:ABS	MAIN
No.	HI	LO	
BIN 1:	OFF	OFF	
BIN 2:	OFF	OFF	
BIN 3:	OFF	OFF	
BIN 4:	OFF	OFF	EXIT

**1** Select

**2** F 1 ▶ Selects the main parameter.

**3** Select [%].

BIN	MAIN	Z:%	REF: 1.00000k
No.	HI	LO	
BIN 1:	OFF	OFF	
BIN 2:	OFF	OFF	
BIN 3:	OFF	OFF	
BIN 4:	OFF	OFF	EXIT

Select

F 2 ▶ Selects percentage mode.

**4** Select the main parameter reference value.

BIN	MAIN	Z:%	REF: 10.0000k
No.	HI	LO	NUM
BIN 1:	OFF	OFF	
BIN 2:	OFF	OFF	
BIN 3:	OFF	OFF	
BIN 4:	OFF	OFF	EXIT

Select

- 5** Enter a value with the tenkey and accept it with the **ENTER** key. **10KEY**  
 Settable range: -9.99999G to 9.99999G

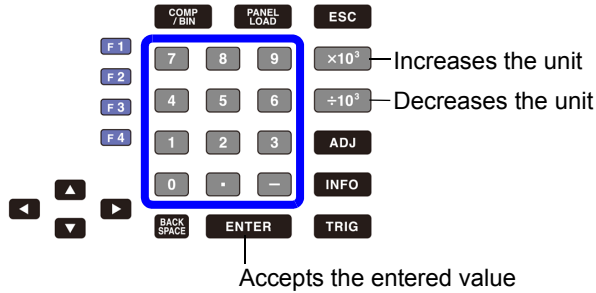

Unit:  
 (a/f/p/n/ $\mu$ /m/none/k/M/G)

If you make a mistake:  
 Press **BACK SPACE** key and reenter the value.

- 6** Select the BIN number and select the upper and lower limit values.

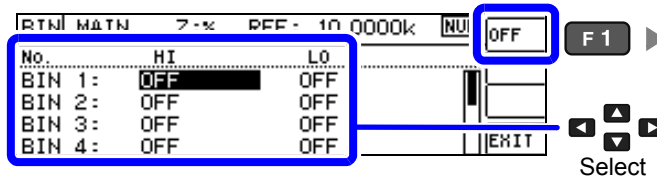

Does not set an upper or lower limit value.

- 7** Enter a value with the tenkey and accept it with the **ENTER** key. **10KEY**  
 Settable range: -9.99999 G to 9.99999 G

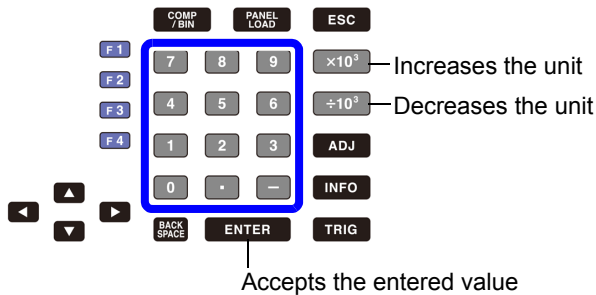

Unit:  
 (a/f/p/n/ $\mu$ /m/none/k/M/G)

If you make a mistake:  
 Press **BACK SPACE** key and reenter the value.

## 4.4 Judging Measurement Results

### Sub parameter settings

**1** Select the [SUB] parameter.

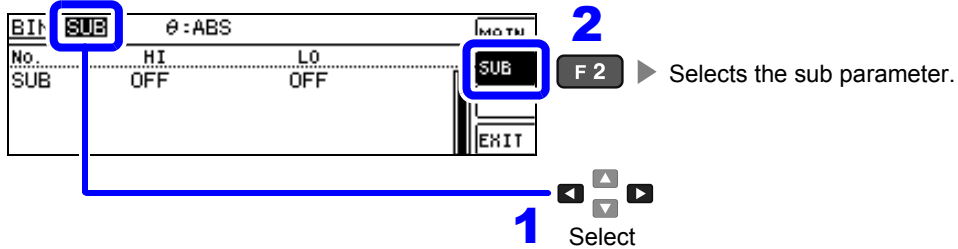

**2** Select [%].

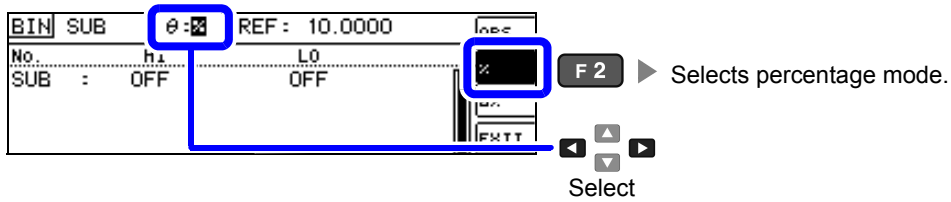

**3** Select the sub parameter reference value.

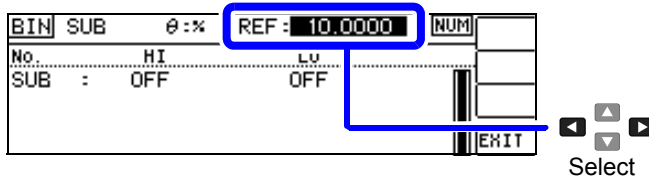

**4** Enter a value with the tenkey and accept it with the **ENTER** key. **10KEY**  
 Settable range: -9.9999 G to 9.9999 G

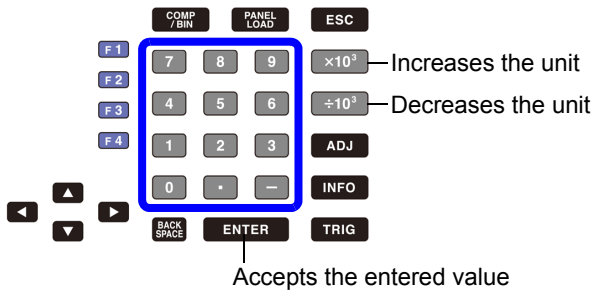

Unit:  
 (a/f/p/n/μ/m/none/k/M/G)

If you make a mistake:  
 Press **BACK SPACE** key and reenter the value.



**5** Set the sub parameter upper and lower limit value.

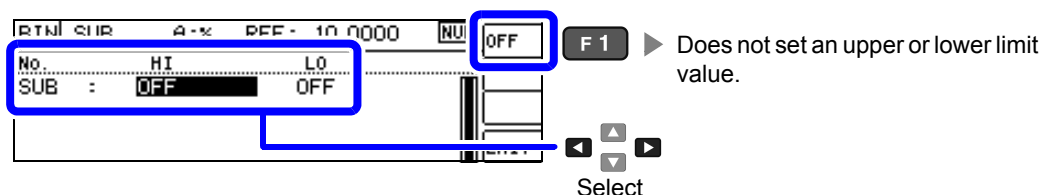

**6** Enter a value with the tenkey and accept it with the **ENTER** key. **10KEY**  
 Settable range: -9.99999 G to 9.99999 G

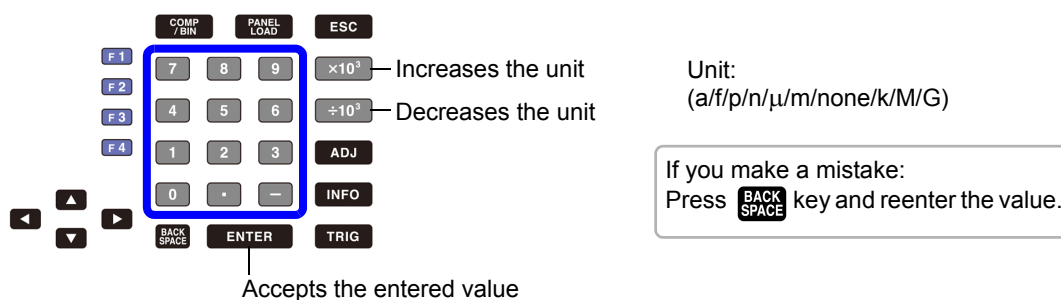

Upper limit value

- The upper limit value is set as a percentage of the reference value.
- In terms of the instrument's actual internal operation, the upper limit comparison value is calculated using the following equation and compared with the measurement value to make a judgment.

$$\text{Upper limit comparison value} = \text{reference value} + |\text{reference value}| \times \frac{\text{Percentage set value}}{100}$$

Lower limit value

- The lower limit value is set as a percentage of the reference value.
- In terms of the instrument's actual internal operation, the lower limit comparison value is calculated using the following equation. To set a value that is less than the measurement value, it is necessary to enter a negative percentage.

$$\text{Lower limit comparison value} = \text{reference value} + |\text{reference value}| \times \frac{\text{Percentage set value}}{100}$$

**7**

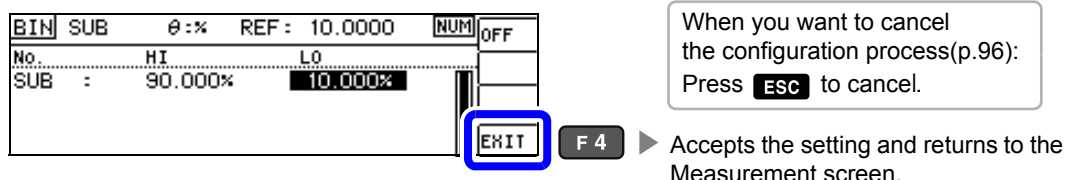

## 4.4 Judging Measurement Results

### 3 Setting Upper and Lower Limit Values as( $\Delta\%$ )Values Relative to the Offset from the Reference Value(Deviation Percentage Mode)

The upper and lower limit values can be set as a percentage based on the reference value, and the amount of deviation from the reference value can be displayed as the measurement value in the form of a percentage.

**NOTE** Set the judgment mode to [BIN].

See "Setting the judgment mode" (p. 75)

- In deviation percentage mode, the amount of deviation ( $\Delta\%$ ) from the reference value is displayed as the measurement value.
- The method for setting the reference value and the upper and lower limit values is the same as for percentage mode.

See "Setting the Upper or Lower Limit Value as a Percentage (%) Relative to a Reference Value (Percentage mode)" (p. 79)

- The reference value and upper and lower limit values are used by both percentage mode and deviation percentage mode.

The  $\Delta\%$  value is calculated using the following equation:

$$\Delta\% = \frac{\text{measurement value} - \text{reference value}}{|\text{reference value}|} \times 100$$

#### Main parameter settings

**1** Press **COMP/BIN** key.

**2** Select [MAIN].

**2** Select the main parameter.

**1** Select

**3** Select [ $\Delta\%$ ].

**F 3** Sets the parameter to deviation percentage mode.

Select

**4** Select the main parameter reference value.

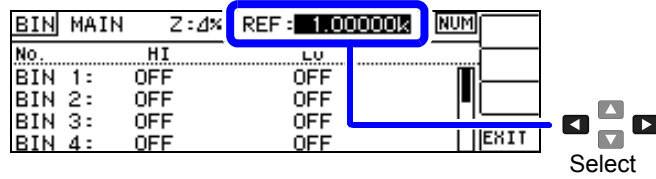

**5** Enter a value with the tenkey and accept it with the **ENTER** key. **10KEY**  
 Settable range: -9.99999 G to 9.99999 G

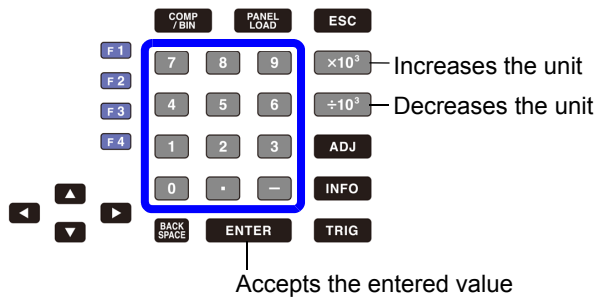

**6** Select the bin number and select the upper and lower limit values.

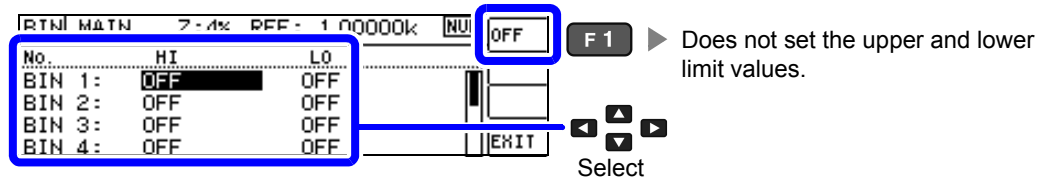

## 4.4 Judging Measurement Results

**7** Enter a value with the tenkey and accept it with the **ENTER** key. **10KEY**  
 Settable range: -9.99999 G to 9.99999 G

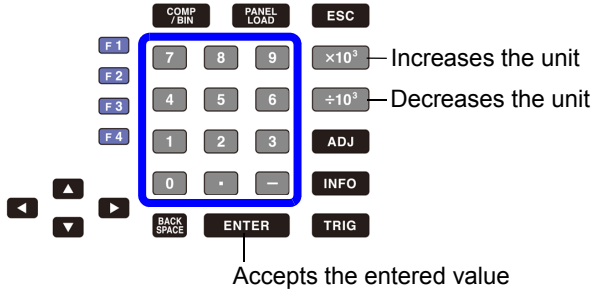

Unit:  
 (a/f/p/n/μ/m/none/k/M/G)

If you make a mistake:  
 Press **BACK SPACE** key and reenter the value.

### Upper limit value

- The upper limit value is set as a percentage of the reference value.
- In terms of the instrument's actual internal operation, the upper limit comparison value is calculated using the following equation and compared with the measurement value to make a judgment.

$$\text{Upper limit comparison value} = \text{reference value} + |\text{reference value}| \times \frac{\text{Percentage set value}}{100}$$

### Lower limit value

- The lower limit value is set as a percentage of the reference value.
- In terms of the instrument's actual internal operation, the lower limit comparison value is calculated using the following equation. To set a value that is less than the measurement value, it is necessary to enter a negative percentage.

$$\text{Lower limit comparison value} = \text{reference value} + |\text{reference value}| \times \frac{\text{Percentage set value}}{100}$$

Sub parameter settings

1 Select the [SUB] parameter.

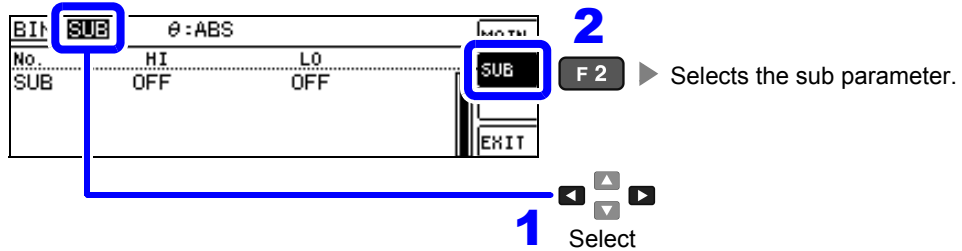

2 Select [ $\Delta\%$ ].

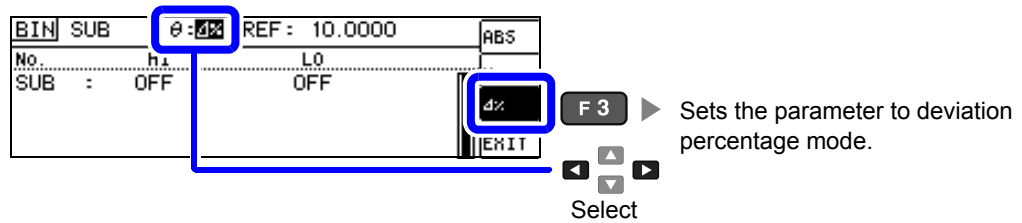

3 Select the sub parameter reference value.

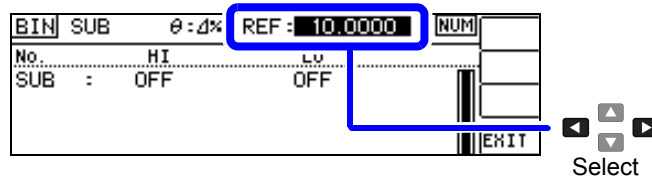

4 Enter a value with the tenkey and accept it with the **ENTER** key. **10KEY**  
 Settable range: -9.99999 G to 9.99999 G

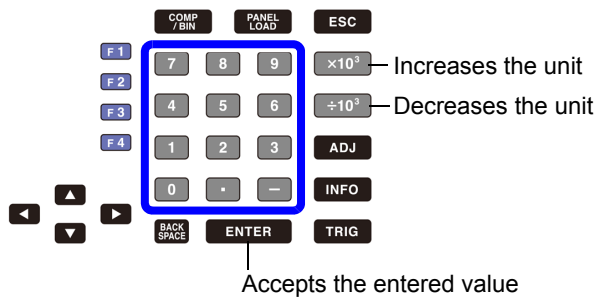

Unit:  
 (a/f/p/n/ $\mu$ /m/none/k/M/G)

If you make a mistake:  
 Press **BACK SPACE** key and reenter the value.

4.4 Judging Measurement Results

5 Set the sub parameter upper and lower limit values.

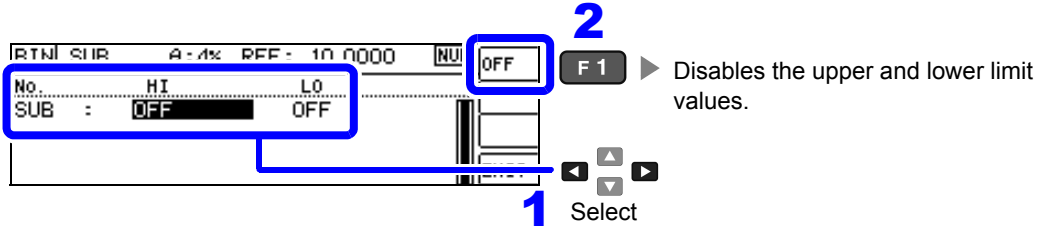

6 Enter a value with the tenkey and accept it with the **ENTER** key. **10KEY**  
 Settable range: -9.99999 G to 9.99999 G

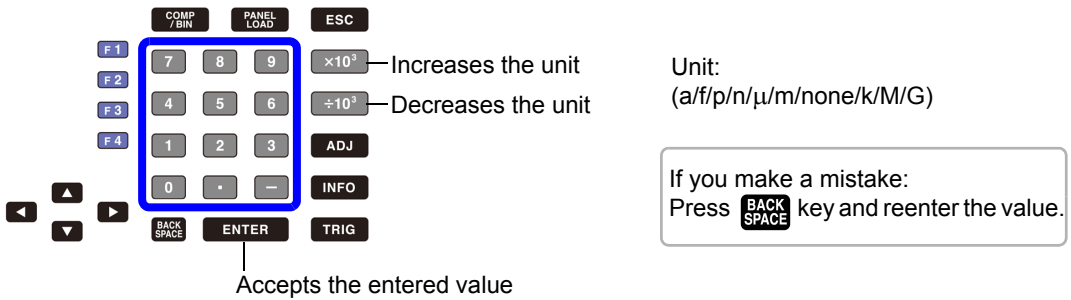

The Δ% value is calculated using the following equation:

$$\Delta\% = \frac{\text{measurement value} - \text{reference value}}{|\text{reference value}|} \times 100$$

7

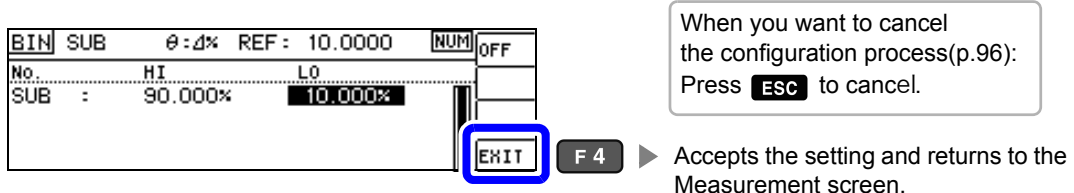

When you want to cancel the BIN measurement setting:

When you want to cancel the comparator measurement setting, you can press **ESC** .

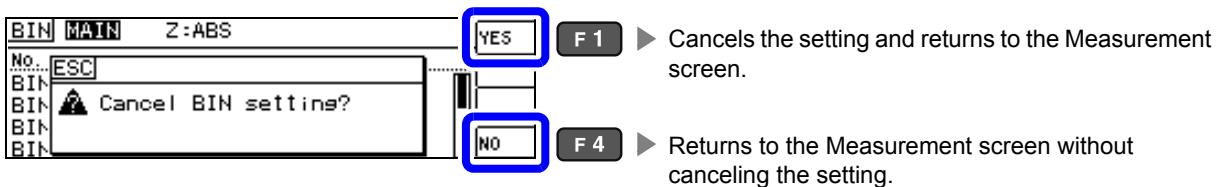

# 4.5 Setting Application Settings

## 4.5.1 Saving Measurement Results (Memory function)

You can save the measurement results inside the instrument. (Up to 32,000 items) The saved measurement results can be acquired using a communication command.

The items saved to memory are in accordance with the `:MEASure:VALid` setting.

For details on how to acquire the saved measurement results or set `:MEASure:VALid`, refer to the Communications commands in the included LCR Application Disk documentation .

- 1 Open the Advanced Settings screen.



- 2 Set `[MEMORY]` to `[OFF]`.  
You will not be able to change the number of measurement results if `[MEMORY]` is not set to `[OFF]`.

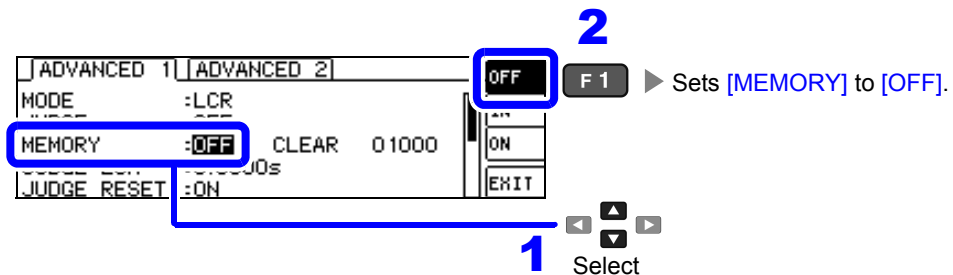

- 3 Set the number of measurement results. **DIGIT**
- Settable range: 1 to 32000

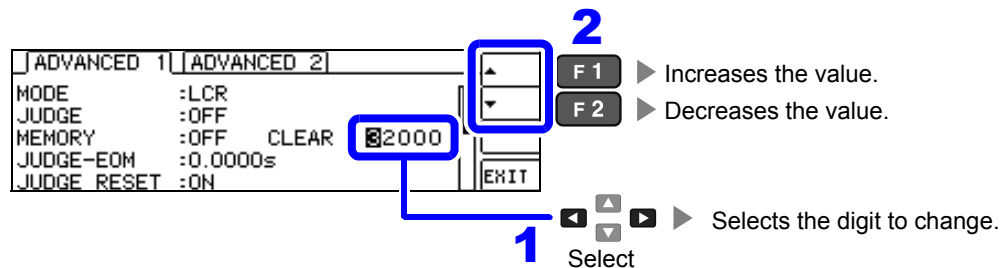

4.5 Setting Application Settings

4 Set [MEMORY] to [ON], [IN], or [OFF].

1 Select

2

- F 1 ▶ Disables the memory function.
- F 2 ▶ Saves measurement values when all judgment results are IN.
- F 3 ▶ Saves all measurement values.

**NOTE**

- When comparator and BIN functionality have not been selected, IN operation is the same as ON operation.
- When the memory function is set to IN, measurement values are not saved if even one comparator result is HI or LO, or if the BIN result is OUT or SUBNG.

Clearing all measurement values saved in the instrument's memory

1 Select

2

- F 1 ▶ Clears all saved measurement values.

**NOTE**

Selecting [CLEAR] when no measurement results have been saved will cause the instrument to beep.

5

1 Select

2

- F 4 ▶ Returns to the Measurement screen.

**NOTE**

- If the memory function is enabled (ON/IN), the number of memory items currently saved is displayed in the measurement screen.

Indicates that the number of memory items currently saved is 2,929.

- Measurement results saved internally by the instrument can be acquired with the **:MEMORY?** Command.
- See Communications commands in the included LCR Application Disk documentation
- The internal data is lost when the memory function setting is changed.
- In continuous measurement mode, only measurements for panels for which the memory function is enabled are saved.
- When the instrument memory becomes full, the following message appears on the measurement screen. If this message appears, subsequent measurement results will not be saved. To resume saving, load or clear the measurement results from the instrument memory.

M.FULL



## 4.5.2 Setting the Detection Signal Waveform Averaging Count (Waveform Averaging Function)

The number of measurement waveforms for each frequency band is set for the measurement speed settings (FAST, MED, SLOW, SLOW2), and this function allows you to set the number of measurement waveforms for each frequency band. Having more waveforms increases the measurement precision, while having fewer waveforms increases the measurement speed.

### **NOTE**

- The waveform averaging count can be set using communications commands only. It cannot be set from the instrument.
- When the waveform averaging function is set, the measurement speed setting is unavailable. To set a measurement speed, first cancel the waveform averaging function setting.  
**See** Communications commands in the included LCR Application Disk documentation (**:WAVE**)
- The measurement waveform count for each measurement speed can be set with the **:WAVE:RESet** communications command. Additionally, the measurement waveform count can be set to 1 for all frequency bands with **:WAVE:RESet FAST2**.  
**See** Communications commands in the included LCR Application Disk documentation (**:WAVE:RESet**)
- When changing the waveform count for an individual frequency band, do so within the valid setting range outlined in the table below.  
No. 2 to 4 provide compatibility with the IM3533 and cannot be used by this instrument.  
**See** Communications commands in the included LCR Application Disk documentation (**:WAVE:NUM**)

No.	Frequency band	Valid setting range
1	DC	1 to 24 <sup>*1</sup>
5	40.000 Hz to 99.999 Hz	1 to 40
6	100.00 Hz to 300.00 Hz	1 to 50
7	300.01 Hz to 500.00 Hz	1 to 200
8	500.01 Hz to 1.0000 kHz	1 to 300
9	1.0001 kHz to 2.0000 kHz	1 to 600
10	2.0001 kHz to 3.0000 kHz	1 to 1200
11	3.0001 kHz to 5.0000 kHz	1 to 2000
12	5.0001 kHz to 10.000 kHz	1 to 3000
13	10.001 kHz to 20.000 kHz	1 to 1200 <sup>*2</sup>
14	20.001 kHz to 30.000 kHz	1 to 480 <sup>*3</sup>
15	30.001 kHz to 50.000 kHz	1 to 800 <sup>*3</sup>
16	50.001 kHz to 100.00 kHz	1 to 1200 <sup>*3</sup>
17	100.01 kHz to 200.00 kHz	1 to 2400 <sup>*3</sup>

<sup>\*1</sup>:The No.1 DC measurement waveform count performs waveform averaging using the set line frequency as one wave.

<sup>\*2</sup>:When using No.13, 5 times the number of waves set with the waveform averaging count are averaged.

<sup>\*3</sup>:Nos.14 to 17 are used, 25 times the number of waves set with the waveform averaging count are averaged.

4.5 Setting Application Settings

4.5.3 Setting the Delay Time from the Output of Comparator and BIN Judgment Results until Output of EOM (LOW) and Resetting Judgment Results

You can set the delay time for the period from the output of the comparator and BIN judgment results until the output of EOM (LOW) from the EXT I/O. In addition, you can also select whether to reset the comparator and BIN judgment results when they are EOM (HIGH).

See "9.2 Timing Chart" (p.184)

1 Open the Advanced Settings screen.

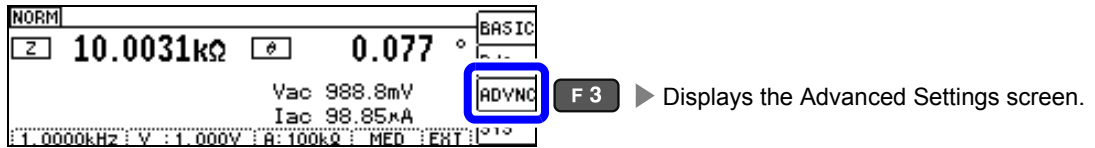

2 Set the EOM (low) output delay time based on the comparator and BIN judgment results. Settable range: 0.0000 s to 0.9999 s DIGIT

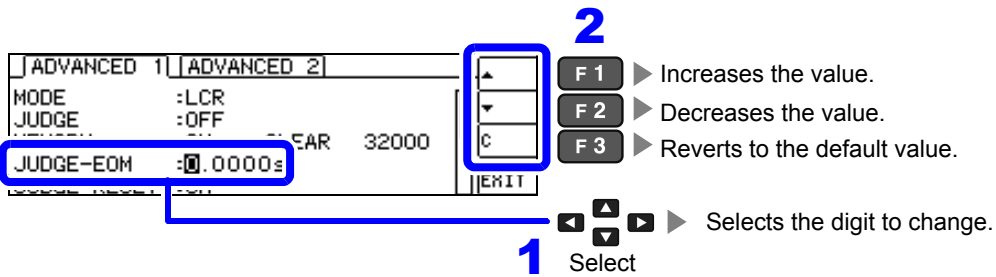

3 Select whether to reset the comparator and BIN judgment results when they are EOM (HIGH).

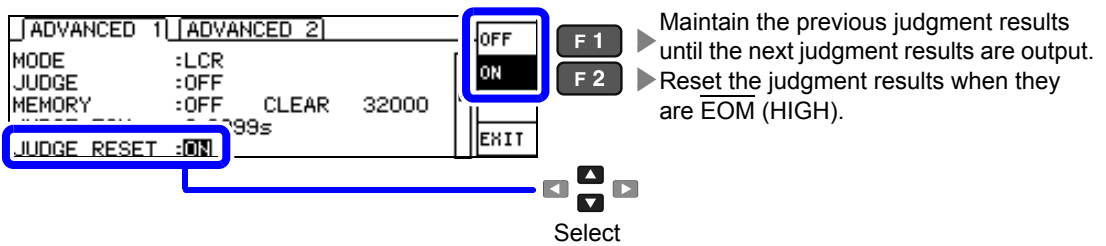

4 EXIT F4 Returns to the Measurement screen.

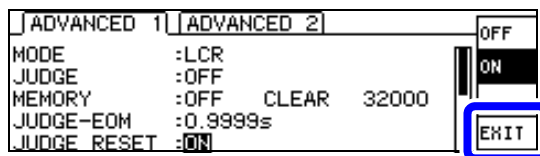

### 4.5.4 Enabling Trigger Input for during Measurement and Setting the Valid Edge of Trigger Input

You can select whether to enable or disable trigger input from the EXT I/O during measurement (during EOM (HI) output). Erroneous input due to chattering can be prevented by disabling trigger input during measurement. Furthermore, you can also select either the rising edge or falling edge as the valid edge of trigger input from the EXT I/O.

See "9.2 Timing Chart" (p.184)

- 1 Open the Advanced Settings screen.

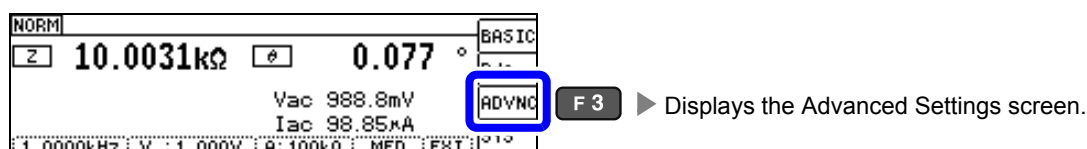

- 2 Select [TRIG ENABLE] and set trigger input from EXT I/O during measurement (while outputting EOM (HI) after the trigger is received) to [ON] or [OFF].

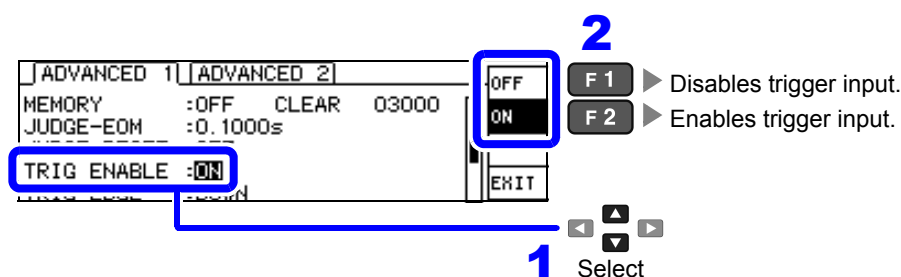

- 3 Select [TRIG EDGE] and set the rising or falling edge as the trigger input effective edge.

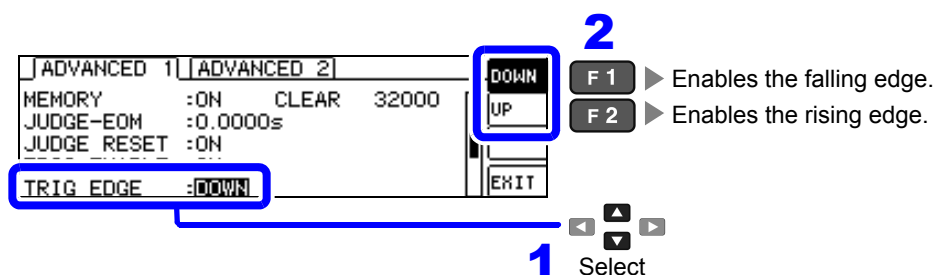

- 4

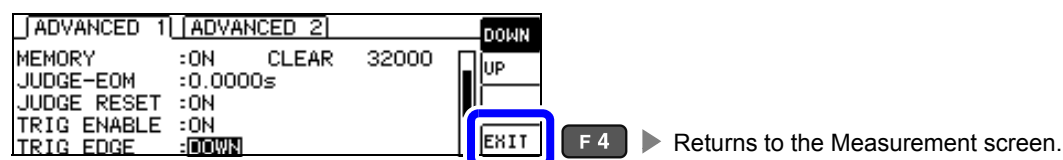

4.5 Setting Application Settings

4.5.5 Setting the EOM Output Method

The duration of the time period for which  $\overline{\text{INDEX}}$  and  $\overline{\text{EOM}}$  are high (off) decreases as the measurement frequency increases. If the high (off) time is too short for reasons related to the input circuit architecture when  $\overline{\text{INDEX}}$  and  $\overline{\text{EOM}}$  are received, it is possible to configure settings so that the low (on) signal state is maintained for the set time after  $\overline{\text{EOM}}$  changes to low (on) when measurement completes before reverting the signal to high (off). The output method can be similarly changed for  $\overline{\text{INDEX}}$ .

See "Chapter 9 External Control" (p.177)

1 Open the Advanced Settings screen.



2 Select [EOM MODE] and set the output method.

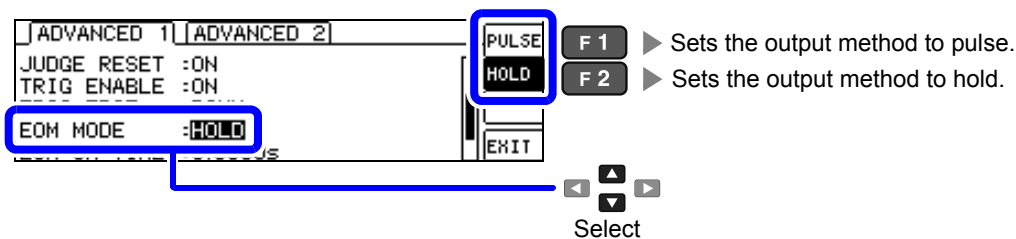

Timing charts when set to hold or pulse:  
See "Chapter 9 External Control" (p.177)

3 Select [EOM-ON-TIME] and set the EOM output time to use with pulse EOM mode. **DIGIT**  
Settable range: 0.0001 s to 0.9999 s

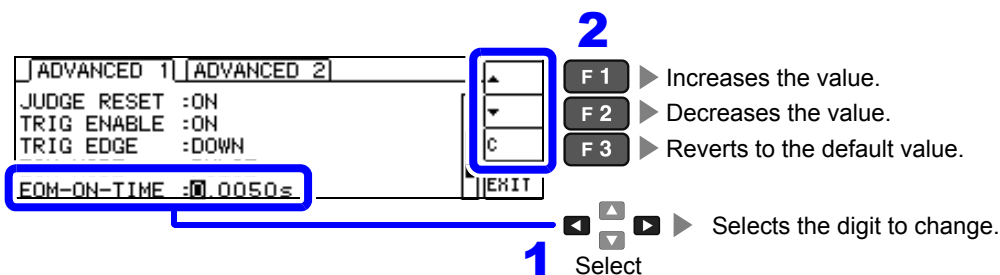

**NOTE**

The output time cannot be set unless the output method is set to pulse.

4



## 4.5.6 Checking Contact Defects and the Contact State (Contact Check Function)

This functionality allows you to detect contact defects between the terminals (HCUR, HPOT, LCUR, and LPOT) and the sample during 4-terminal measurement.

See Contact Check Error display(p.222)

- 1 Open the Advanced Settings screen.



- 2 Select [CONTACT].

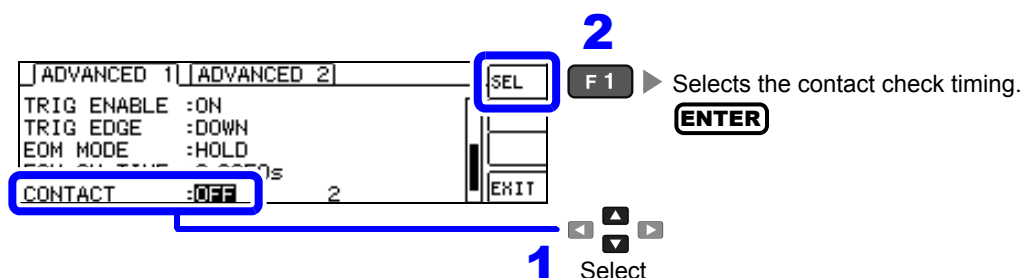

- 3 Select the timing at which to perform contact check operation.

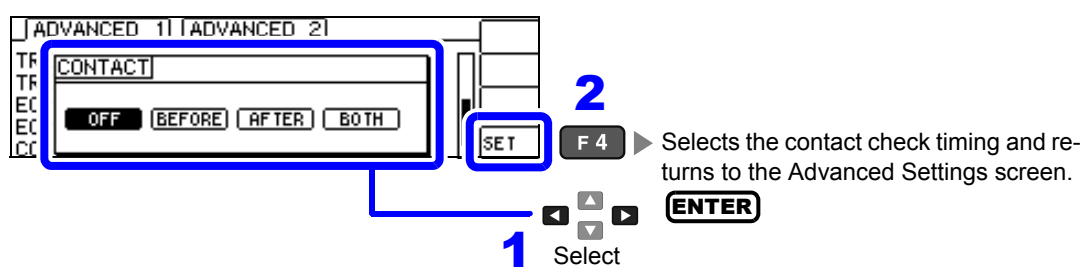

Available contact check timing settings

OFF	Disables the contact check function.
BEFORE	Performs a contact check before measurement.
AFTER	Performs a contact check after measurement.
BOTH	Performs a contact check before and after measurement.

## 4.5 Setting Application Settings

- 4** Set the contact check threshold. **DIGIT**  
Settable range :1 to 5

threshold	1	2	3	4	5
Permissible contact resistance [ $\Omega$ ]	about 1000	about 500	about 100	about 50	about 10

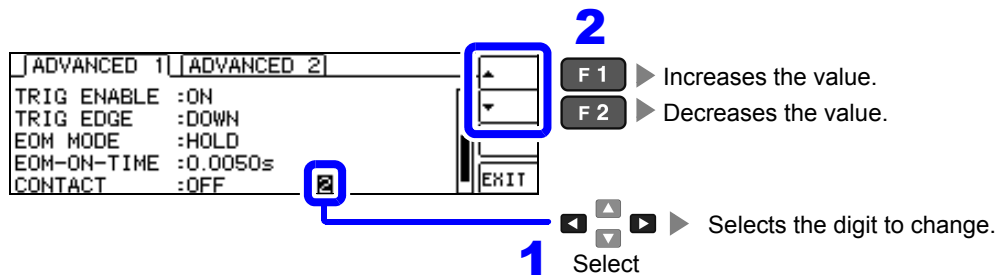

**5**

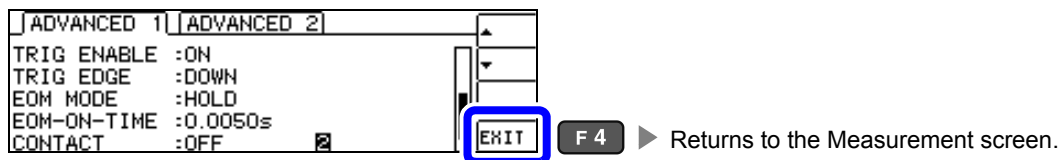

### **NOTE**

- Setting the contact check timing to **[BOTH]** or **[BEFORE]** causes the trigger synchronous output function to be automatically turned on.
- See "Applying the signal to the sample during measurement only (Trigger Synchronous Output Function)" (p. 57)
- When setting a contact check threshold, the index time and EOM time will be delayed depending on the timing. (p.214)
- The allowable contact resistance value may fluctuate depending on the sample being measured.
- When **[BEFORE]** timing causes a contact check error, the measurement value will not be saved, even if the memory function is enabled.
- When the sample is a high-capacitance capacitor, the contact check function may not operate under some measurement conditions.

### 4.5.7 Detecting OPEN during 2-terminal Measurement (HIGH-Z Reject Function)

This function is for outputting a measurement terminal connector error when the measurement result is high relative to the set judgment reference value. The setting value can be set as an absolute value, and the error is output via the measurement screen and the EXT I/O. On the Measurement screen, this error is output as [Hi Z].

See "Chapter 9 External Control" (p.177)

The judgment reference is calculated from the nominal value (range name) of the current measurement range and the judgment reference value as shown below.

$$\text{Judgment reference} = \text{Nominal value of current measurement range} \times \text{Judgment reference value (\%)}$$

Example    Current measurement range nominal value    :10 kΩ  
               Judgment reference value                                :150%  
               Judgment reference = 10 k × 1.50 = 15 k

- 1 Open the Advanced Settings screen.



- 2 Set the Hi Z reject function to [OFF] or [ON].

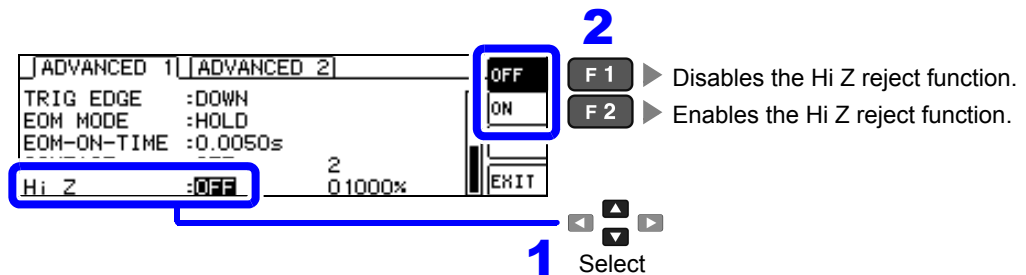

## 4.5 Setting Application Settings

**3** Set the judgment reference value. **DIGIT**  
Settable range: 0 to 30000%

A ratio is set using the range name as the reference value.  
Example: When the 1 k $\Omega$  range is used: A ratio to the value of 1 k $\Omega$  is set.

The screenshot shows the 'ADVANCED 1' settings menu. The 'Hi Z' parameter is currently set to '01000%'. A blue box highlights the '0' digit, with a blue arrow pointing to it from the number '1' below. To the right of the menu, a vertical box highlights the '▲' (up) and '▼' (down) arrow keys, with a blue arrow pointing to them from the number '2' above. Further to the right, three function keys are listed: 'F 1' (Increases the value.), 'F 2' (Decreases the value.), and 'F 3' (Reverts to the default value.). Below these, a set of four arrow keys (left, up, right, down) is shown with a blue arrow pointing to them from the number '1' below, and the text 'Select' next to it.

**4**

The screenshot shows the 'ADVANCED 1' settings menu. The 'Hi Z' parameter is now set to '02500%'. A blue box highlights the 'EXIT' button at the bottom right of the menu, with a blue arrow pointing to it from the number '4' to its left. To the right of the 'EXIT' button, the text 'F 4' is shown with a right-pointing arrow and the text 'Returns to the Measurement screen.'



## 4.5.8 Turning the LCD Display On and Off

The LCD display can be turned on and off. You can save power by turning the LCD display off, which will cause the display to turn off when there is no key operation for 10 seconds. (This setting is the same as the continuous measurement function's LCD display on/off function.)

- 1 Open the Advanced Settings screen.

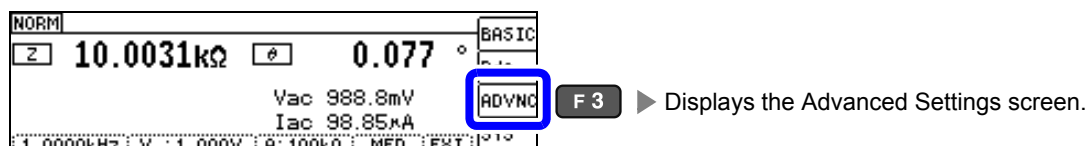

- 2 Select the [ADVANCED2] tab.

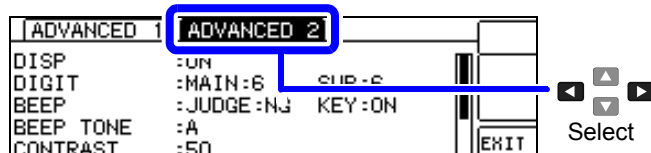

- 3 Select [DISP] and set the LCD display to [OFF] or [ON].

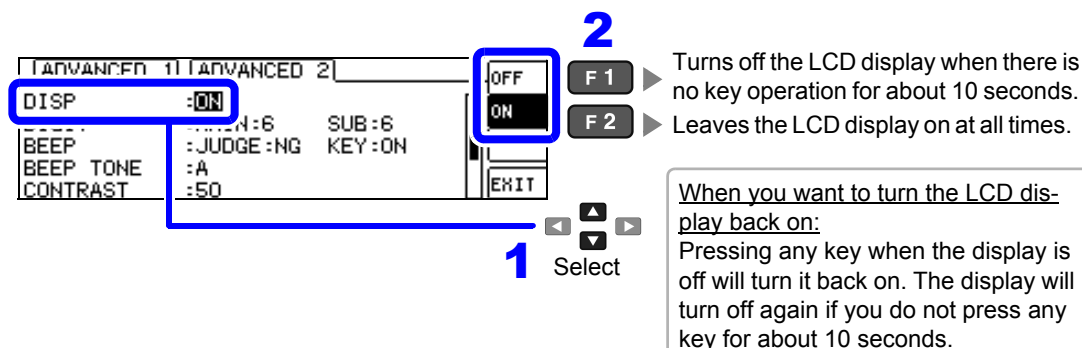

- 4

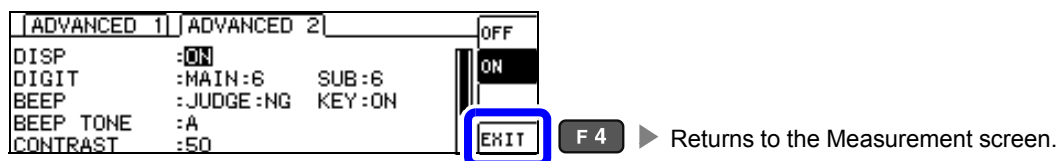

4.5 Setting Application Settings

4.5.9 Setting the Number of Display Digits

You can set the number of effective digits of the measurement value for each parameter.

1 Open the Advanced Settings screen.

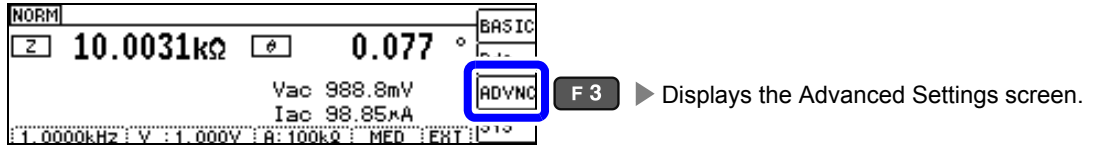

2 Select the [ADVANCED2] tab.

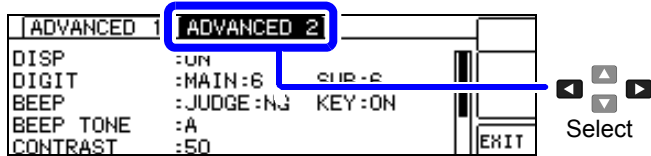

3 Set the number of display digits for the main parameter. **DIGIT**  
 Settable range: 3 to 6 digits

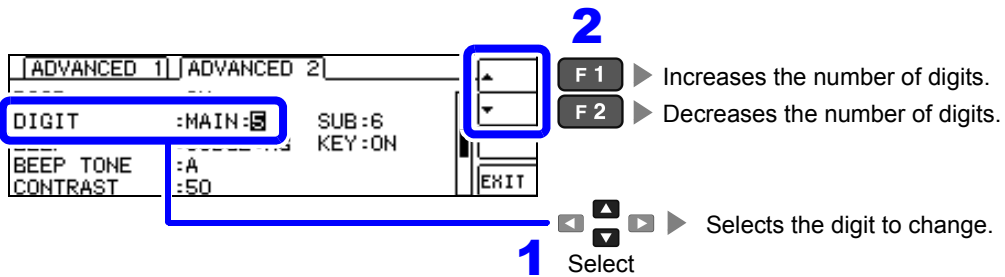

4 Set the number of digits to display for the sub parameter. **DIGIT**  
 Settable range: 3 to 6 digits

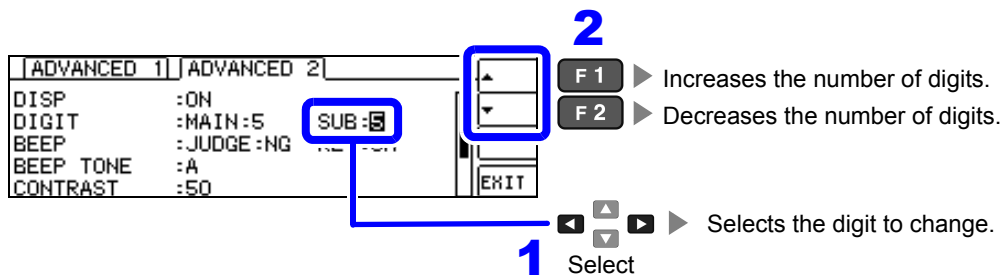

5

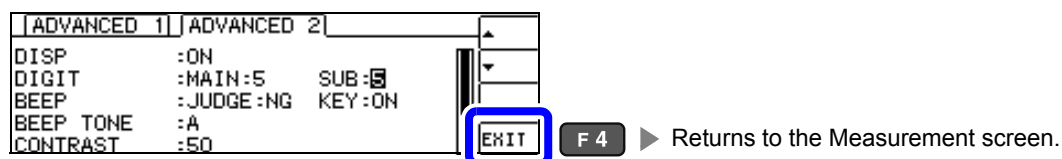

List of setting values by parameter

Setting Value	Parameter				
	$\theta$	D	Q	$\Delta\%$	Other
6	3 decimal digits	5 decimal digits	2 decimal digits	3 decimal digits	Full 6 digits
5	2 decimal digits	4 decimal digits	1 decimal digit	2 decimal digits	Full 5 digits
4	1 decimal digit	3 decimal digits	0 decimal digits	1 decimal digit	Full 4 digits
3	0 decimal digits	2 decimal digits	0 decimal digits	0 decimal digits	Full 3 digits

**NOTE** Minute values may not be displayed using the set number of digits.

## 4.5 Setting Application Settings

### 4.5.10 Setting Operation Sounds (Beep Sounds)

You can set the operation sound and each of the beep sounds for judgment results. You can also select from four beep settings.

#### 1 Reporting judgment results with beep operation

1 Open the Advanced Settings screen.

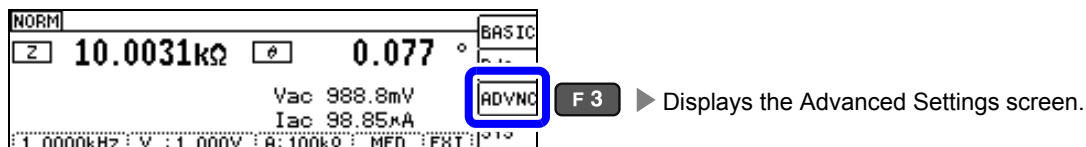

2 Select the **[ADVANCED2]** tab.

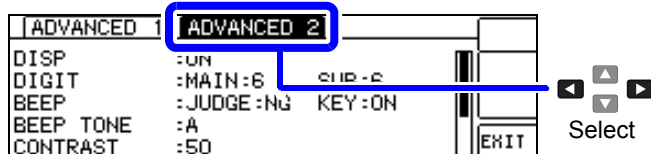

3 Set beep operation to **[OFF]**, **[IN]**, or **[NG]**.

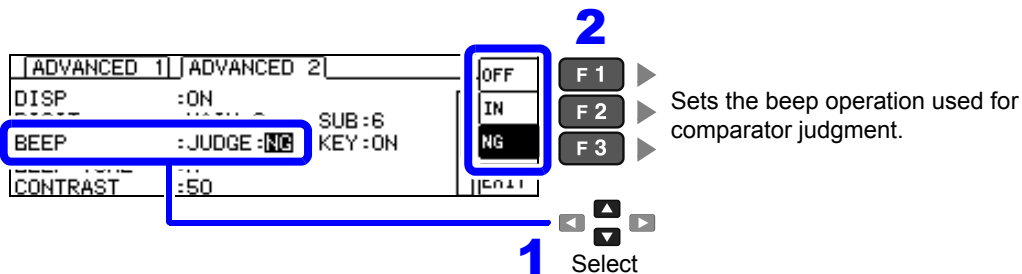

Comparator judgment beep settings	
OFF	Disables beep operation during comparator judgment.
When making judgments with 1 comparator	
IN	Beeps when the result is IN.
NG	Beeps when the result is LO or HI.
When making judgments with 2 comparators	
IN	Beeps when both results are IN.
NG	Beeps when either of the results is LO or HI.

4

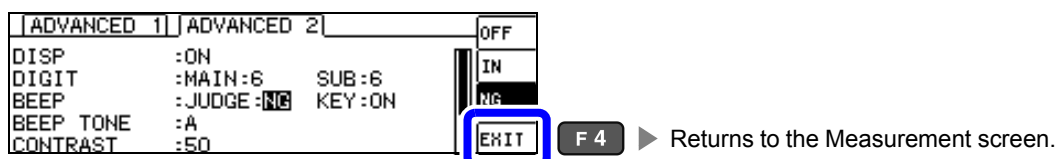

## 2 Turning the key tone on and off

- 1 Open the Advanced Settings screen.

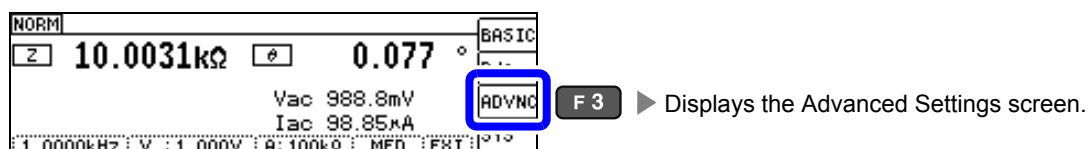

- 2 Select the **[ADVANCED2]** tab.

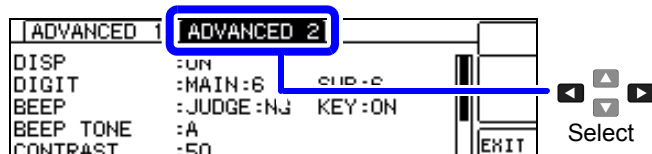

- 3 Turn the key tone on or off.

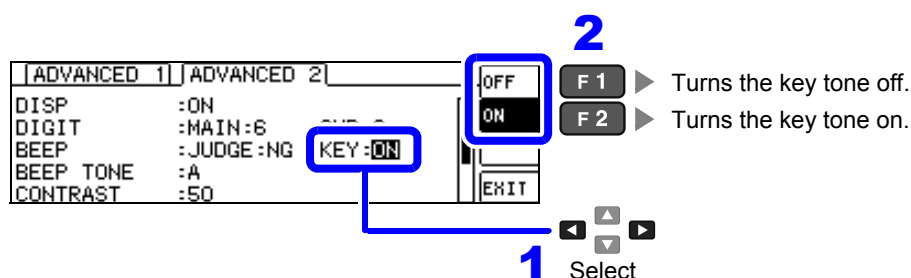

## 4

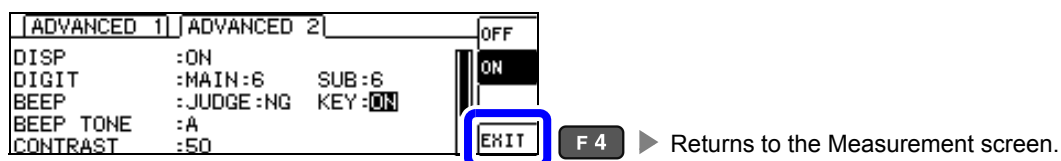

**NOTE** If an invalid key is pressed or an operation causes an error, an error tone will sound regardless of whether the beep tone is turned on or off.

## 4.5 Setting Application Settings

### 3 Changing the beep tone and key tone

**1** Open the Advanced Settings screen.

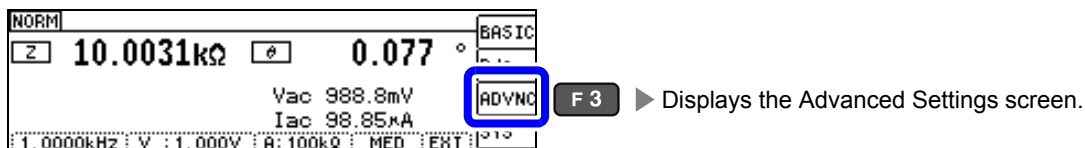

**2** Select the [ADVANCED2] tab.

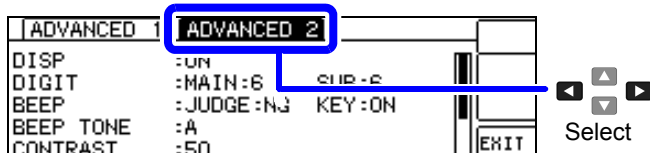

**3** Select the desired tone. **DIGIT**  
You can select from four tones (A to D).

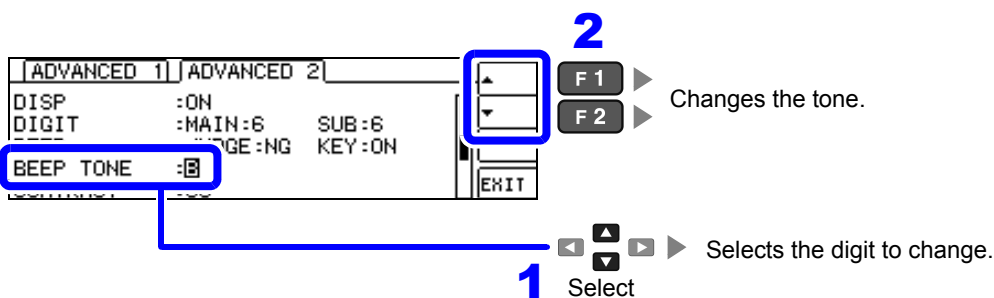

#### NOTE

No beep will sound if the key tone is set to OFF. To listen to sample beeps while you change the setting, enable key tone.

See "Setting Operation Sounds (Beep Sounds)" (p. 110)

**4**

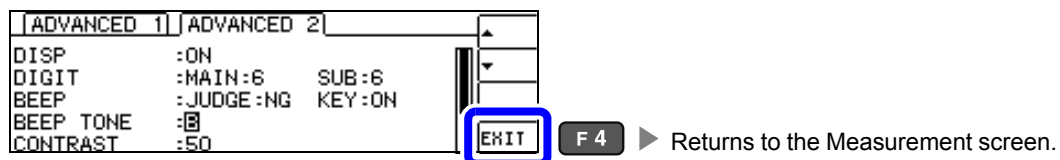

### 4.5.11 Adjusting the Screen Contrast

The screen may become difficult to see if the ambient temperature changes. If this occurs, adjust the screen's contrast.

- 1 Open the Advanced Settings screen.

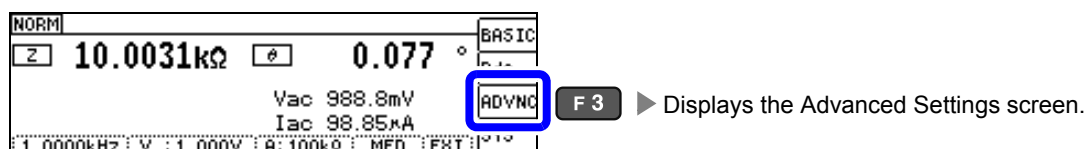

- 2 Select the [ADVANCED2] tab.

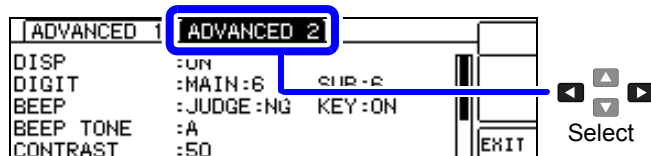

- 3 Adjust the screen contrast.  
Settable range: 0 to 100% (in 5% increments)

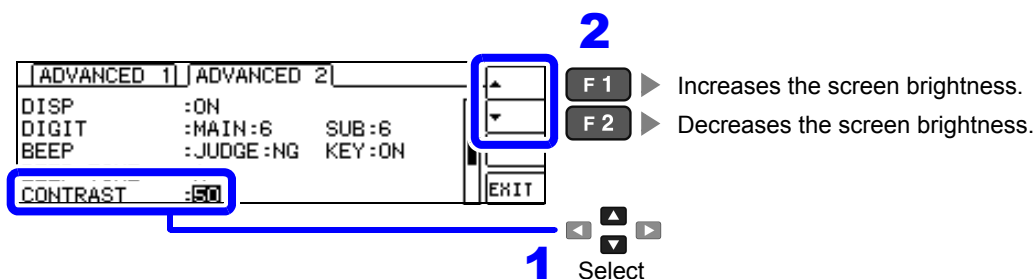

- 4

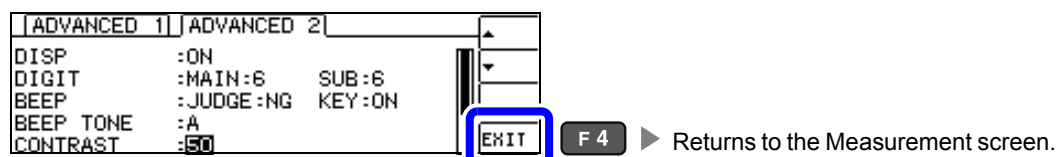

### 4.5.12 Disabling Key Operation (Key-lock Function)

There are two types of key-lock mode: full key lock, which disables all setting changes, and set key lock, which enables comparator and BIN measurement settings and the panel load function but disables other setting changes. Use the key lock mode that best suits your application. You can also set a passcode (PIN number).

- 1 Open the Advanced Settings screen.

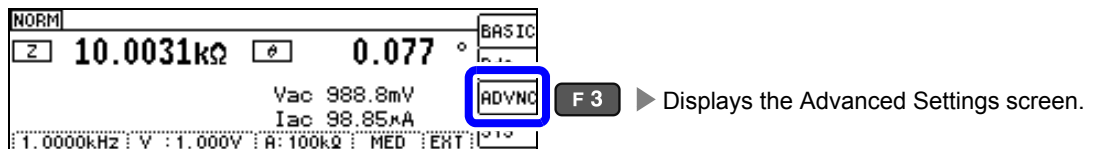

- 2 Select the [ADVANCED2] tab.

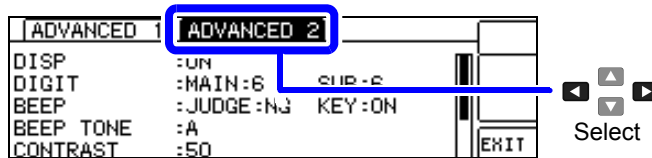



**3** Select the key lock setting conditions.

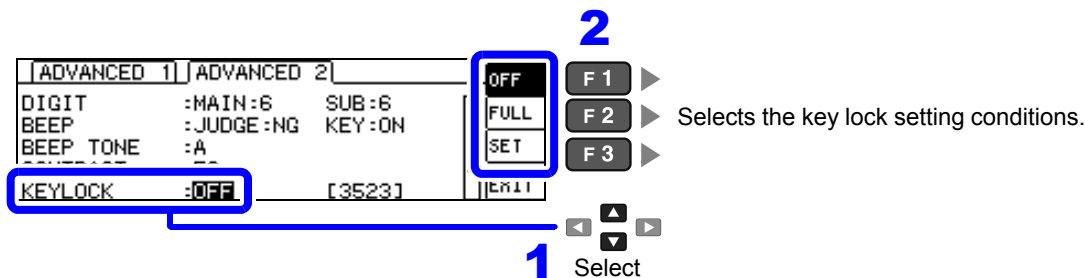

Key lock setting conditions	
OFF	Disables the key-lock function.
FULL	Protects settings by disabling all setting changes other than canceling key lock. You can check measurement conditions with the <b>INFO</b> key. During comparator measurement, you can only check the limit value with the <b>◀ ▶</b> keys. During BIN measurement, you can check limit values with the tenkey ( <b>0</b> to <b>9</b> and <b>.</b> ) or the <b>◀ ▶</b> keys.
SET	<ul style="list-style-type: none"> <li>• Comparator and BIN measurement settings, accessed with <b>COMP/BIN</b> key.</li> <li>• Panel load function, accessed with <b>PANEL LOAD</b> key.</li> <li>• Canceling key lock</li> </ul> Settings are protected by disabling all setting changes other than the above. You can check measurement conditions with the <b>INFO</b> key. During comparator measurement, you can only check the limit value with the <b>◀ ▶</b> keys. During BIN measurement, you can check limit values with the tenkey ( <b>0</b> to <b>9</b> and <b>.</b> ) or the <b>◀ ▶</b> keys.

**4** Pressing [EXIT] enables key lock mode.

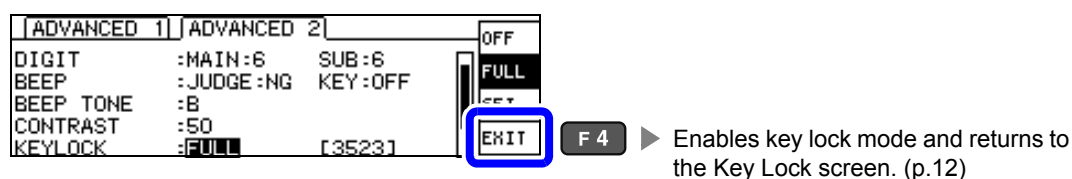

### **NOTE**

- In the case of an external trigger, the key lock is not enabled for **TRIG** key.
- Turning off the power does not cancel the key-lock function.
- Set and verify the passcode before activating key lock mode.

See "Setting the Passcode of the Key-lock" (p. 116)

## 4.5 Setting Application Settings

### Setting the Passcode of the Key-lock

**1** Open the Advanced Settings screen.

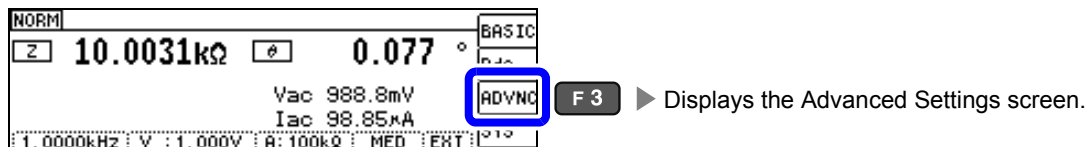

**2** Select the [ADVANCED2] tab.

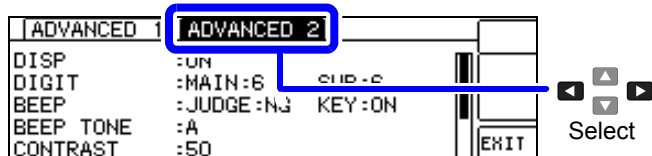

**3** Select the key lock passcode.

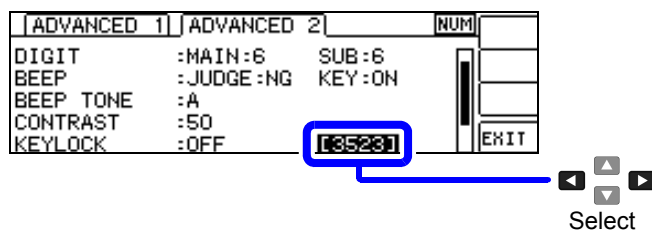

**4** Enter a value with the tenkey and accept it with the **ENTER** key. **10KEY**  
 Settable range : 1 to 4 digits  
 Default password : 3523

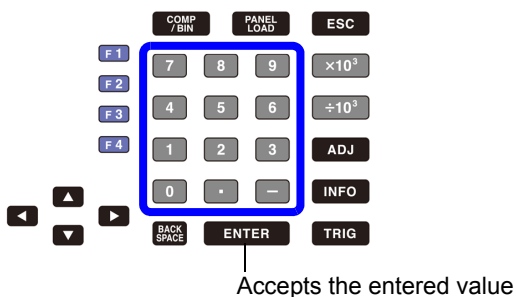

If you make a mistake:  
 Press **BACK SPACE** key and reenter the value.

**NOTE** When a passcode has been set, that passcode must be entered in order to cancel key lock mode. Take steps to ensure you do not forget the set passcode.

## Canceling key lock mode

- 1** Select **[UNLCK]** on the Key Lock screen.



**F1** ▶ Select **[UNLCK]** on the Key Lock screen. Displays the Passcode Entry screen.

- 2** Enter the passcode. **[10KEY]**  
If no passcode has been set, select **[UNLCK]** without entering anything.

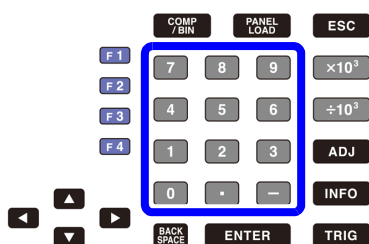

- The entered passcode will be displayed on the screen with asterisks.
- To erase entered text, press **[BACK SPACE]** key.

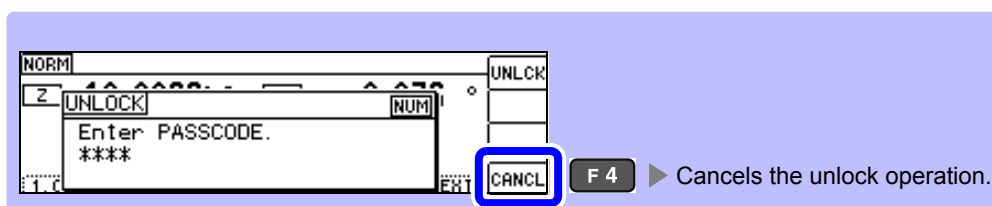

**F4** ▶ Cancels the unlock operation.

- 3** Select **[UNLCK]**.

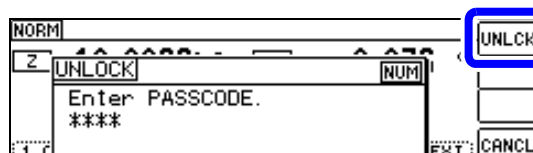

**F1** ▶ Cancels key lock mode and returns to the Measurement screen.

Pressing **[ENTER]** key also cancels key lock mode and returns to the Measurement screen.

**NOTE** If you forget the passcode, perform a full reset to revert the instrument to its factory settings. (p.221)

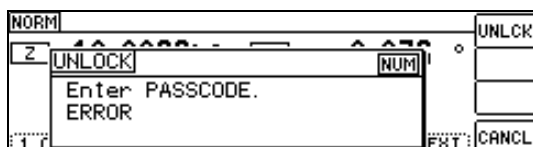

If the above error is displayed, check the following:

Cause: UNLCK was pressed before the passcode was entered.

Solution: Press **[BACK SPACE]** key and enter the passcode.

Cause: The entered passcode is incorrect.

Solution: Press **[BACK SPACE]** key and reenter the passcode.

### 4.5.13 Initializing (System Reset)

In the event of the instrument malfunctioning, check "Before returning for repair" (p. 217). If you do not know the cause of the problem, perform a system reset to restore the instrument to its factory default settings.

See "Appendix11 Initial Settings Table"(p. A16)

A system reset can also be performed with the **\*RST** and **:RESet** communication commands.

See Communications commands in the included LCR Application Disk documentation (**\*RST**), (**:PRESet**)

- 1 Open the Advanced Settings screen.

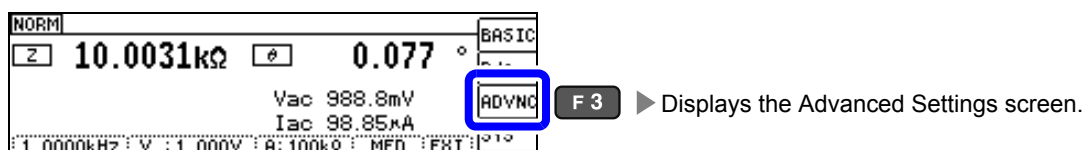

- 2 Select the [ADVANCED2] tab.

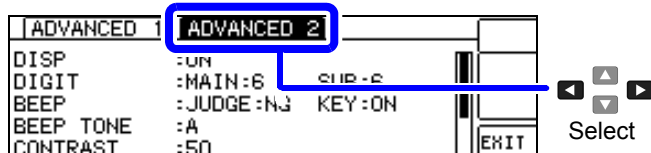

- 3 Select [RESET].

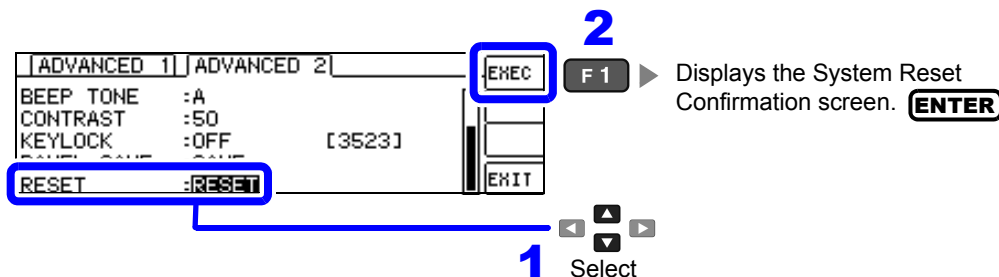

- 4 Select [YES] or [NO] for the system reset.

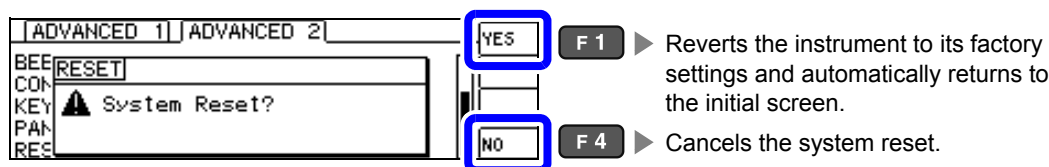

**NOTE**

- If the initialization screen cannot be displayed, perform a full reset. (p.221)
- The instrument returns to factory default when the system is reset. Please remove the test sample to be measured before performing a system reset.

# Continuous Measurement Function Chapter 5

## 5.1 About Continuous Measurement Function

The continuous measurement function loads measurement conditions saved with the panel save function and performs up to two measurements in succession.

### 5.1.1 Measurement screen

When the instrument is turned back on, the display reflects the measurement mode in use when it was last turned off. For more information about screen layouts, see (p.17).

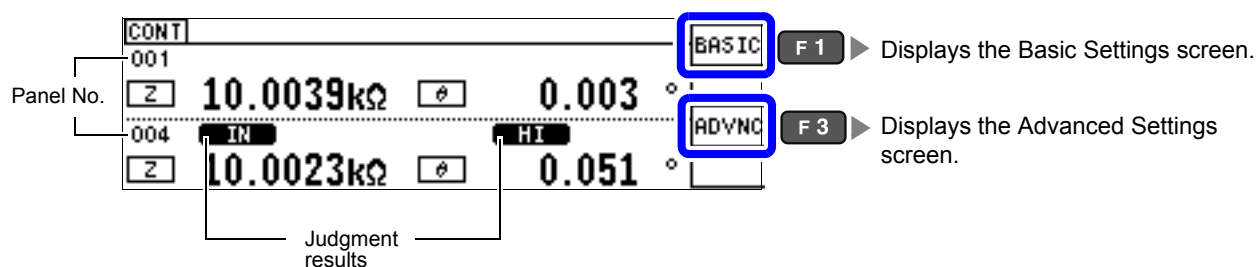

- NOTE**
- Setting the measurement conditions so that the measurement frequency or measurement signal level differs for each panel allows you to simply evaluate the characteristics of the test sample.
  - Continuous measurement can also be performed from the EXT I/O. (p.178)
  - If the power is turned off when the Continuous Measurement Screen is displayed, the Continuous Measurement Screen will be displayed when the instrument starts the next time you turn the power on.

### 5.1.2 Setting Continuous Measurement

**1** Open the Advanced Settings screen.

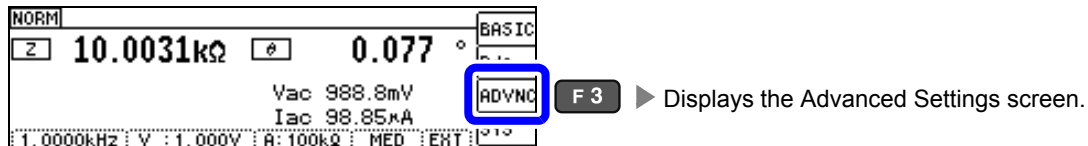

**2** Select [MODE].

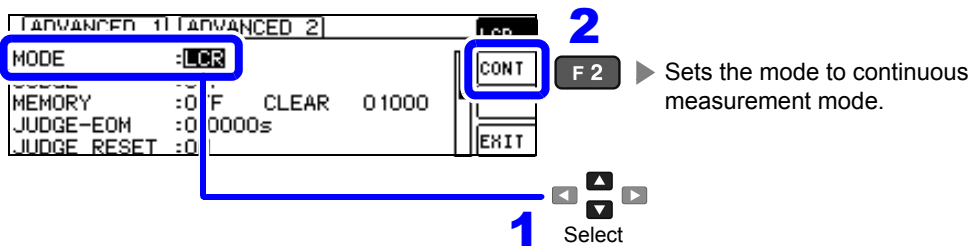

**3** Set the mode.

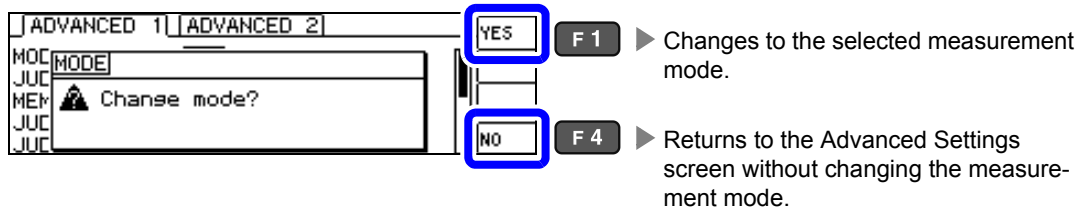

**4** The measurement mode will be changed to continuous measurement mode.

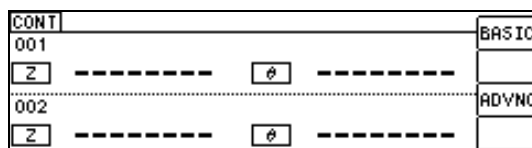

## 5.2 Configuring Basic Settings for Continuous Measurement

Before performing continuous measurement, you must specify which panel to target for continuous measurement. First, use the panel save function to save the desired measurement conditions.

See "7.1 Saving Measurement Conditions (Panel Save Function)" (p. 162)

- 1 Open the Basic Settings screen.

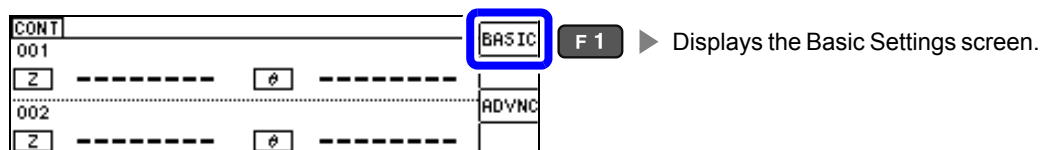

- 2 Select a panel.  
Panels for which only compensation values (ADJ) have been saved will not be shown.

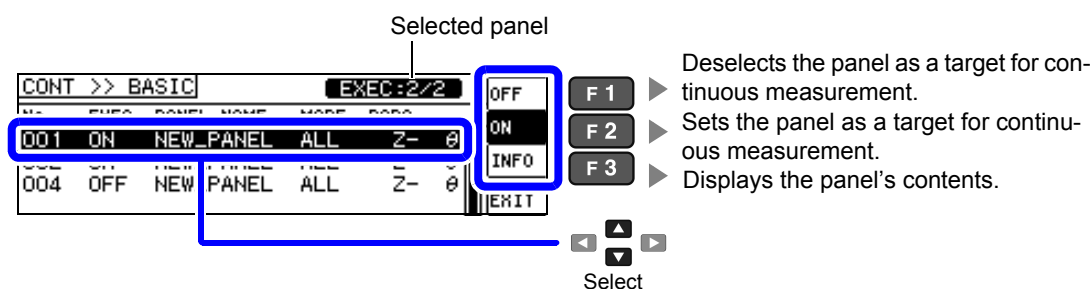

Measurement condition display (when [INFO] is selected)

See "1.3.9 Information Screen" (p. 20)

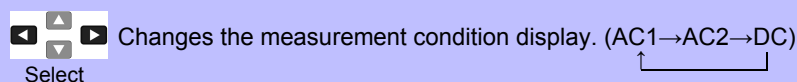
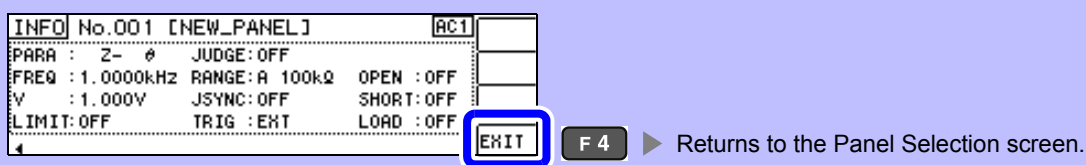

- 3

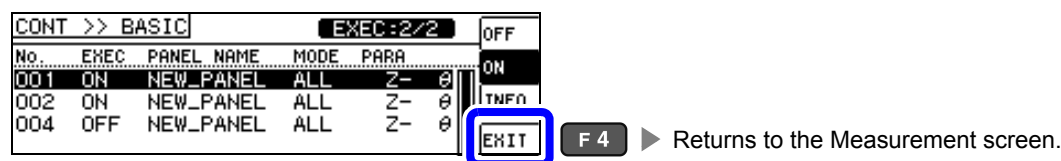

**NOTE** You can select up to two panels. Attempting to select three or more panels will cause the instrument to beep. To change panels, first set the panel you wish to not use to off.

## 5.3 Performing Continuous Measurement

- 1 Configure continuous measurement settings.  
See "5.2 Configuring Basic Settings for Continuous Measurement" (p. 121)
- 2 When you return to the initial screen, the panel numbers you enabled on the Panel Settings screen will be shown.

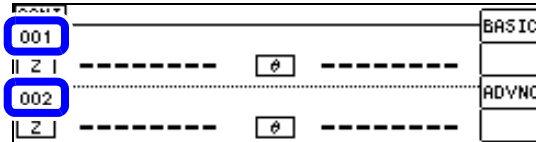

- 3 Continuous measurement will be performed each time you press **TRIG** key.
- 4 The measurement results will be displayed.

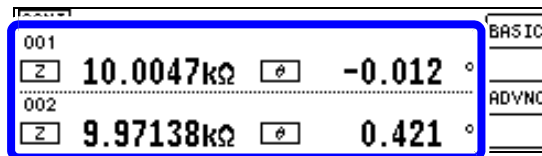



## 5.4 Configuring Application Settings for Continuous Measurement

### 5.4.1 Setting the Display Timing

Set the draw timing for during continuous measurement.

If the display timing is set to **[REAL]**, the time for continuous measurement becomes long because the screen is updated every time measurement is performed.

If it is set to **[AFTER]** to give priority to the measurement time, the screen update time becomes short.

- 1 Open the Advanced Settings screen.

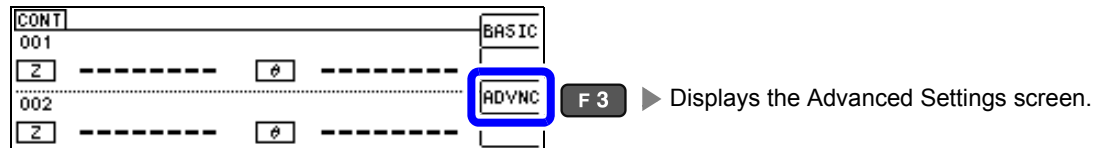

- 2 Set the display timing.

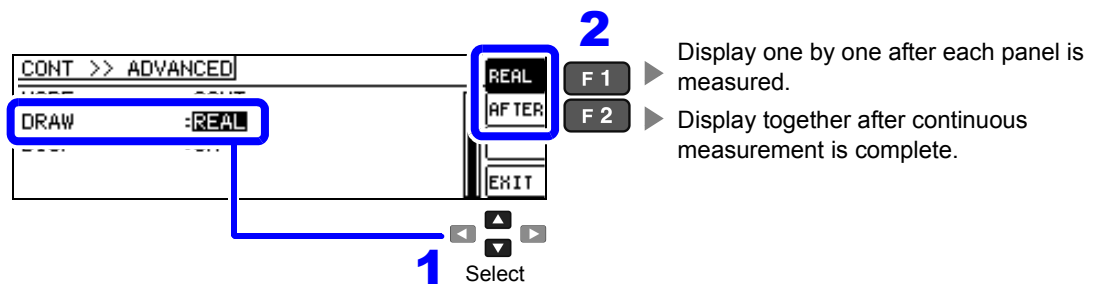

- 3

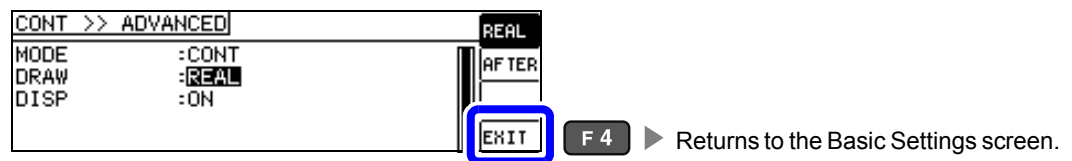

## 5.4 Configuring Application Settings for Continuous Measurement

### 5.4.2 Setting the LCD to ON/ OFF

You can turn the display backlight on and off. When the backlight is set to [OFF] it will turn off when no keys are operated for 10 seconds to save power.

(This setting is the same as the LCR function's backlight on/off function.)

- 1 Open the Advanced Settings screen.

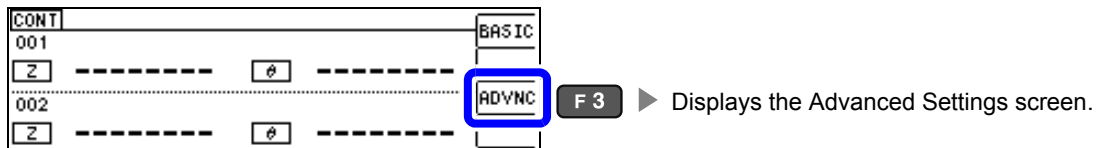

- 2 Set the backlight to [ON] or [OFF].

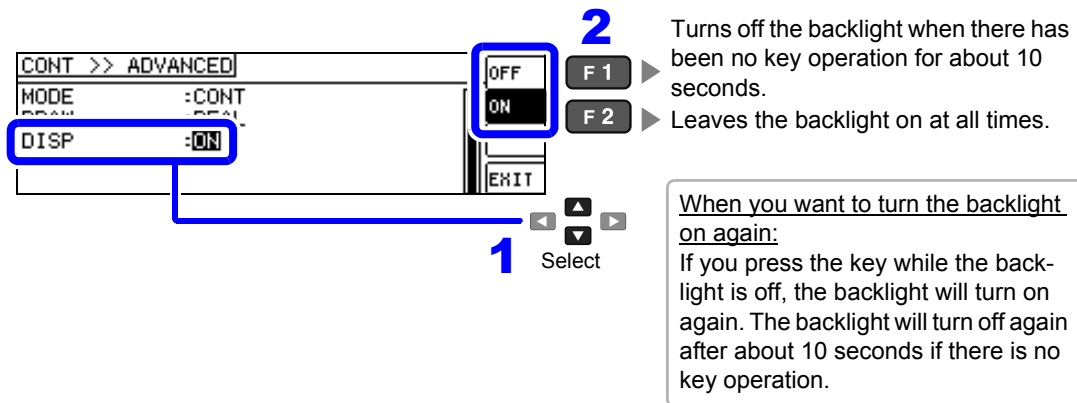

- 3

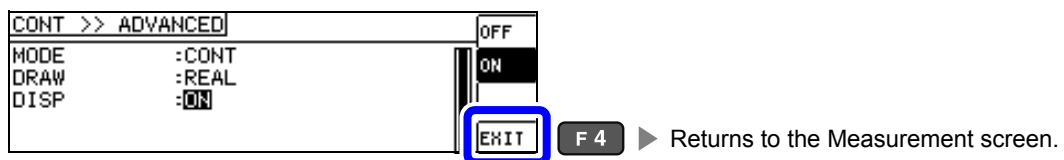

# Error Compensation

# Chapter 6

Compensate for errors caused by a fixture or measurement cable.

## 6.1 Setting Open Circuit Compensation

With open circuit compensation, it is possible to reduce the influence of the floating impedance of the test cables and thereby to enhance the accuracy of measurement.

It is effective for test samples whose impedance is relatively high.

The comparator decision mode can be set as one of the following:

<b>All Compensation</b>	▶	The compensation values are obtained for all test frequencies. (p.127) You can set the range of measurement frequencies to correct. (p.129)
<b>Spot Compensation</b>	▶	The compensation values are obtained at the set measurement frequency only. (p.131)
<b>OFF</b>	▶	Open circuit compensation data becomes invalid. (p.135)

- NOTE**
- Before open circuit compensation, always set the cable length.  
See "6.4 Compensating Measurement Cable Errors(Cable Length Compensation)" (p. 157)
  - The measurement accuracy values defined in the specifications are for when open circuit compensation and short circuit compensation are performed.
  - Be sure to perform compensation again after replacing the measuring cable.  
You will be unable to obtain correct values if measurement is performed in the compensation state prior to replacement.
  - For SPOT compensation, the open circuit compensation will be valid only when the measurement frequency agrees with the SPOT compensation frequency.
  - When performing compensation, make sure that there is no noise source nearby. Noise may cause an error when performing compensation.  
ex. Servo Motor, switching power source, high-voltage cable and etc.
  - The compensation process should be performed under conditions similar to those in which the sample will be measured.
  - The compensated value is preserved in the memory of the main instrument even when power is turned off.
  - Compensation values cannot be acquired with the continuous measurement mode.
- The **ADJ** key is disabled.

## 6.1 Setting Open Circuit Compensation

### Before performing compensation

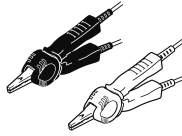
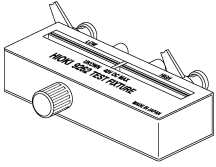

- Route the measurement cables as they will be used during actual measurement. Changes in cable layout may prevent accurate compensation.
- Create an open state between the HIGH terminals and LOW terminals of the probes or fixture in accordance with the width of the measurement object. (Connect HCUR and HPOT, and connect LCUR and LPOT.)
- When the open circuit compensation is performed, execute the guarding process.

**See** "Appendix2 Measurement of High Impedance Components"(p. A3)

(When using the optional 9500-10)

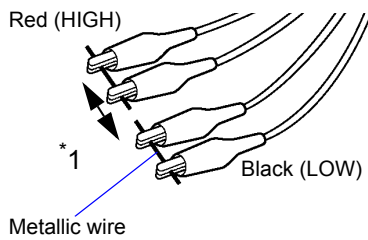

Short the probe's Hcur and Hpot terminals (red) with one metallic wire and its Lcur and Lpot terminals (black) with the other, so that there is no connection between the high and low terminals. Perform open correction.

\*1: Leave the high and low terminals as far apart as they will be when connected to the measurement sample.

### 6.1.1 All Compensation

Simultaneously acquire the open compensation values for all measurement frequencies.  
When limiting the frequency range for ALL compensation  
See "Compensation range limit function" (p.129)

- 1** Press the **ADJ** key while the Measurement screen is displayed to display the Adjust screen.

**NOTE**

The **ADJ** key cannot be used on screens other than the Measurement screen.

- 2** Select **[OPEN]** on the Adjust screen.

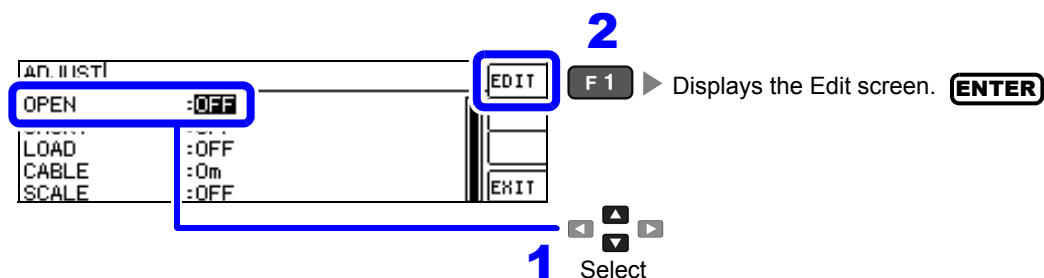

- 3** Select **[TYPE]** on the open compensation Edit screen.

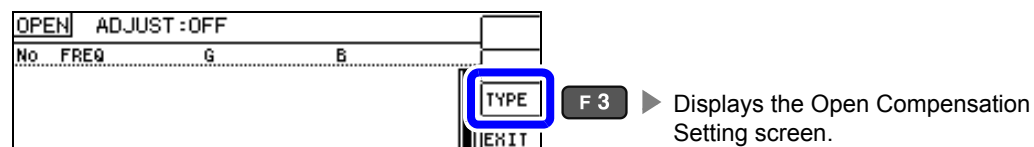

- 4** Select **[ALL]**.



- 5**

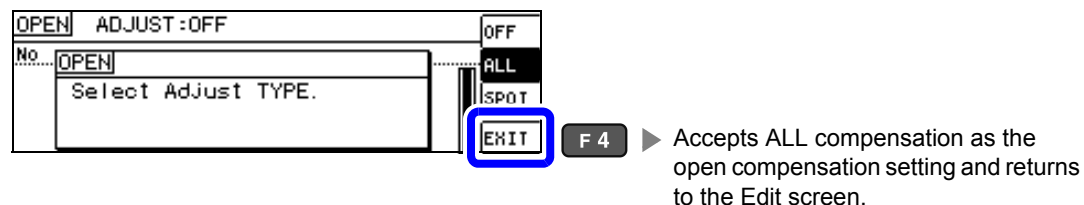

## 6.1 Setting Open Circuit Compensation

**6** Select [EXEC].

OPEN ADJUST:ALL				
No	FREQ	G	B	
01	DC	0.000nS	0.000nS	[EXEC]
02	40.000 Hz	0.000nS	0.000nS	[TYPE]
03	99.999 Hz	0.000nS	0.000nS	[EXIT]
04	100.00 Hz	0.000nS	0.000nS	

- F 1** ▶ Performs open compensation.
- F 2** ▶ Limits the compensation range. (p.129)
- F 4** ▶ Cancels acquisition of compensation values and returns to the Adjust screen, leaving the previous compensation values enabled.

**NOTE**

- The previous compensation values will be displayed on the confirmation screen. (If compensation has never been performed, 0 will be used as the compensation value.)
- Verify that the measurement cables have been left open.

**7** Open compensation is performed.  
Compensation time: Approx. 45 seconds.

OPEN ADJUST:ALL				
No	FREQ	G	B	
01	DC	0.000nS	0.000nS	[EXEC]
02	40.000 Hz	0.000nS	0.000nS	[TYPE]
03	99.999 Hz	0.000nS	0.000nS	[EXIT]
04	100.00 Hz	0.000nS	0.000nS	

Now Adjusting...	
Progress bar	51%

- F 4** ▶ Cancels open compensation and closes the window. (The previous open compensation values will be used.)

**8** Check the open compensation results.

Compensation no. | Measurement frequency | Compensation results (conductance, susceptance)

OPEN ADJUST:ALL				
No	FREQ	G	B	
01	DC	0.112nS	0.000nS	[EXEC]
02	40.000 Hz	0.077nS	-0.001nS	[AREA]
03	99.999 Hz	-0.110nS	0.001nS	[TYPE]
04	100.00 Hz	0.036nS	0.001nS	[EXIT]

When compensation completes normally, the conductance and susceptance will be displayed. Compensation is supported for impedance values of 1 kΩ or greater.

You can check the conductance and susceptance at compensation points with .

- When normal compensation values were not acquired
  - If compensation failed
  - When you want to make open circuit compensation data invalid
- See (p.134)

**9**

OPEN ADJUST:ALL				
No	FREQ	G	B	
01	DC	0.112nS	0.000nS	[EXEC]
02	40.000 Hz	0.077nS	-0.001nS	[AREA]
03	99.999 Hz	-0.110nS	0.001nS	[TYPE]
04	100.00 Hz	0.036nS	0.001nS	[EXIT]

- F 4** ▶ Returns to the Adjust screen.

## Compensation range limit function

In ALL compensation, compensation is performed for all frequency ranges. Using the compensation range limit function, you can set the minimum and maximum compensation frequencies, thereby reducing the time required for the compensation process to complete. The DC on/off setting and the minimum and maximum compensation frequency settings apply to both open and short compensation.

- 1 Select ALL compensation.  
See "All Compensation" (p.127)

- 2 Select [AREA] on the open compensation Edit screen.



- 3 Select DC compensation.

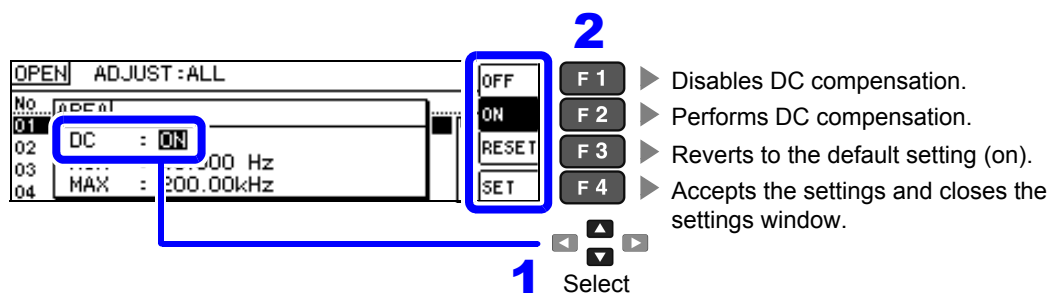

- 4 Set the minimum compensation frequency.

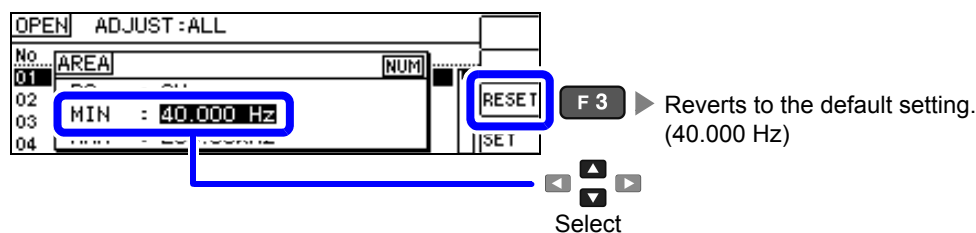

- 5 Enter the desired value with the tenkey and accept it with the **ENTER** key. **10KEY**  
Settable range: 40.000 Hz to 200.00 kHz

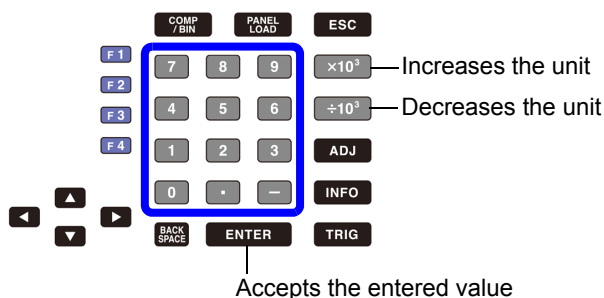

## 6.1 Setting Open Circuit Compensation

**6** Set the maximum compensation frequency.

SCREEN: OPEN ADJUST:ALL  
 No. AREA NUM  
 01 DC : ON  
 02 MAX : 200.00kHz  
 03  
 04

RESET F 3 Reverts to the default setting. (200.00 kHz)

Select

**7** Enter the desired value with the tenkey and accept it with the **ENTER** key. **10KEY**  
 Settable range: 40.000 Hz to 200.00 kHz

COMP /BIN PANEL LOAD ESC  
 F1 F2 F3 F4  
 7 8 9  $\times 10^3$  — Increases the unit  
 4 5 6  $\div 10^3$  — Decreases the unit  
 1 2 3 ADJ  
 0 + - INFO  
 BACK SPACE ENTER TRIG

Unit : (none/k)

If you make a mistake:  
 Press **BACK SPACE** key and reenter the value.

Accepts the entered value

**8**

SCREEN: OPEN ADJUST:ALL  
 No. AREA NUM  
 01 DC : ON  
 02 MIN : 40.000 Hz  
 03 MAX : 200.00kHz  
 04

RESET F 4 Returns to the open compensation Edit screen.

**NOTE** If the maximum compensation frequency is less than the minimum compensation frequency, the minimum and maximum compensation frequencies will be switched automatically.



## 6.1.2 Spot Compensation

Acquire the compensation values at the set measurement frequencies.  
Up to five compensation points can be set for measurement frequencies.

- 1 Press the **ADJ** key while the Measurement screen is displayed to display the Adjust screen.

**NOTE**

The **ADJ** key cannot be used on screens other than the Measurement screen.

- 2 Select **[OPEN]** on the Adjust screen.

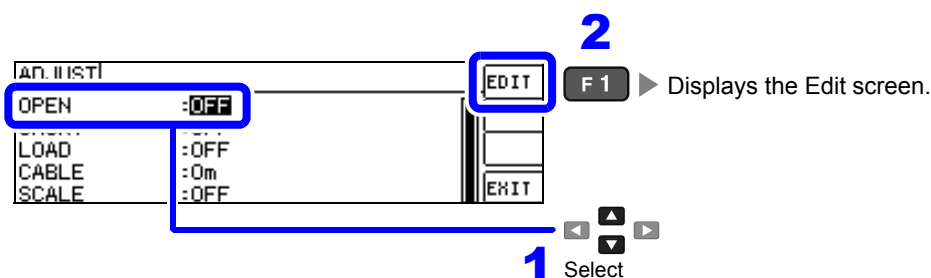

- 3 Select **[TYPE]** on the open compensation Edit screen.

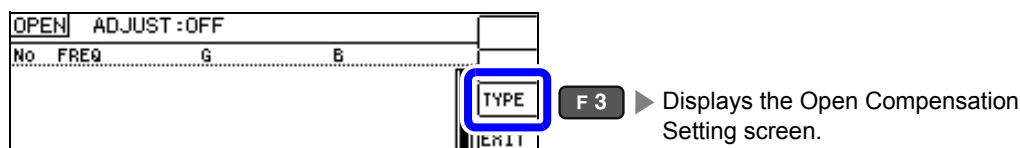

- 4 Select **[SPOT]**.

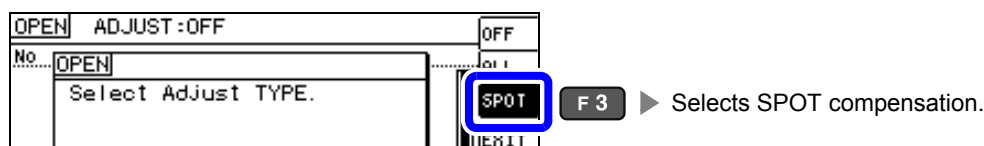

5

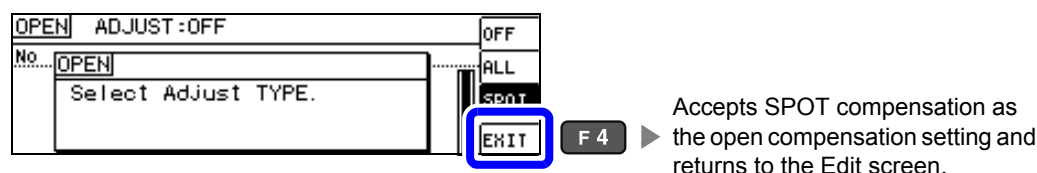

- 6 Select the compensation points you wish to set.

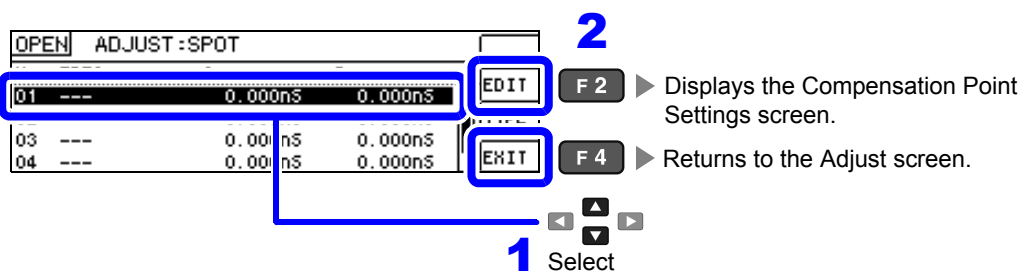

## 6.1 Setting Open Circuit Compensation

**7** Enter the frequency to correct.

OFF (F1) ▶ Disables compensation.  
 DC (F2) ▶ Sets the compensation frequency to DC.

Until a value is entered, the frequency at which SPOT compensation was previously performed is displayed.

**8** Enter a value with the tenkey and accept it with the **ENTER** key. **10KEY**

Unit : (none/k)

×10<sup>3</sup> — Increases the unit  
 ÷10<sup>3</sup> — Decreases the unit

Accepts the entered value

If you make a mistake:  
 Press **BACK SPACE** key and reenter the value.

- Settable range:DC, 40 Hz to 200 kHz
- If you set a frequency in excess of 200 kHz, the frequency will automatically revert to 200 kHz.
- If a frequency of less than 40 Hz is set, the value will be automatically changed to 40 Hz. However, very small values will cause the DC setting to be used.

**9**

SET (F4) ▶ Accepts the frequency to be corrected and returns to the Edit screen.

**10** Select **[EXEC]**.

EXEC (F1) ▶ Performs open compensation.  
 EXIT (F4) ▶ Cancels acquisition of compensation values and returns to the Adjust screen, leaving the previous compensation values enabled.

- NOTE**
- The previous compensation values will be displayed on the confirmation screen. (If compensation has never been performed, 0 will be used as the compensation value.)
  - Verify that the measurement cables have been left open.

6.1 Setting Open Circuit Compensation

11

Open compensation is performed.

The time required to perform the compensation process varies with the measurement frequency and number of points.

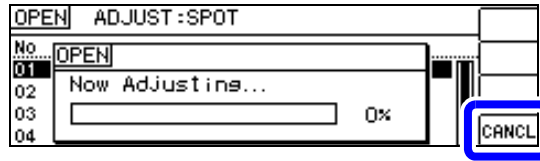

F 4

► Cancels open compensation and closes the window. (The previous open compensation values will be used.)

12

Check the open compensation results.

Compensation no.

Measurement frequency

Compensation results (conductance, susceptance)

You can check the conductance and susceptance at compensation points with .

ADJUST:SPOT		G		B		
No.	FREQ	G	B			
01	100.00kHz	6.861nS	18.398nS			EHEC
02	---	0.000nS	0.000nS			EDIT
03	---	0.000nS	0.000nS			TYPE
04	---	0.000nS	0.000nS			EXIT

When compensation completes normally, the conductance and susceptance will be displayed. Compensation is supported for impedance values of 1 kΩ or greater.

- When normal compensation values were not acquired
  - If compensation failed
  - When you want to make open circuit compensation data invalid
- See (p.134)

13

ADJUST:SPOT		G		B		
No.	FREQ	G	B			
01	100.00kHz	6.861nS	18.398nS			EHEC
02	---	0.000nS	0.000nS			EDIT
03	---	0.000nS	0.000nS			TYPE
04	---	0.000nS	0.000nS			EXIT

F 4

► Returns to the Adjust screen.

## 6.1 Setting Open Circuit Compensation

### When Normal Compensation Values were Not Acquired

If the following error appears when compensation ends, the acquired compensation values will become valid if you press **EXIT** but those compensation values cannot be guaranteed.

Screen when the instrument was unable to acquire

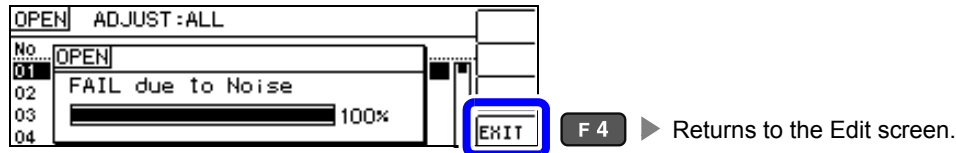

The open circuit compensation process is quite sensitive to noise - both noise originating externally and induced noise. Therefore, if open circuit compensation has been interrupted with a fault, you should check the following points before starting the compensation process again (p.125):

- Check that the test cables are properly connected.
- Check that nothing is connected to the test cables.  
(Open circuit compensation cannot be performed while any test sample is connected to the test cables.)
- Check that the test leads are arranged as closely as possible to their configuration in which measurement will be performed.
- During the compensation process, be sure not to disturb the test cables or to move your hand near them.
- Execute the guarding process.

## If open compensation fails

A window such as the following will be displayed if compensation fails.

When an error message appears and compensation has stopped (when **EXIT** is pressed), the instrument conditions revert to those before the compensation was attempted to be performed.

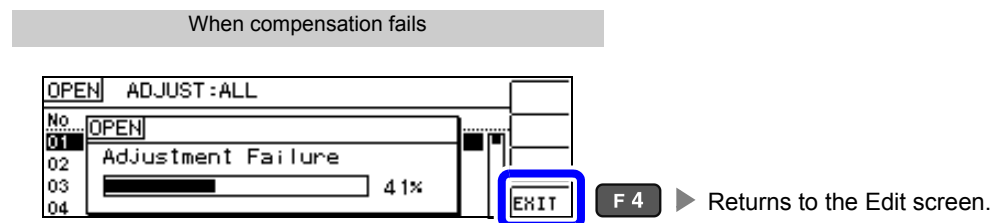

The open circuit compensation process is quite sensitive to noise - both noise originating externally and induced noise. Therefore, if open circuit compensation has been interrupted with a fault, you should check the following points before starting the compensation process again (p.125):

- Check that the test cables are properly connected.
- Check that nothing is connected to the test cables.  
(Open circuit compensation cannot be performed while any test sample is connected to the test cables.)
- Check that the test leads are arranged as closely as possible to their configuration in which measurement will be performed.
- During the compensation process, be sure not to disturb the test cables or to move your hand near them.
- Execute the guarding process.

See "Open compensation or short compensation resulted in an error." (p.220)

## When You Want to Make Open Circuit Compensation Data Invalid

You can invalidate the acquired compensation data and return to the Measurement screen by pressing **OFF** ( **F 1** ) and then **EXIT** ( **F 4** ) in step 4 of the ALL compensation procedure (p.127) or the SPOT compensation procedure (p.131) for open compensation.

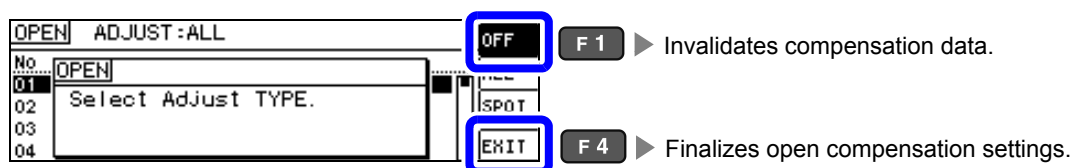

**NOTE** The compensation values that are stored internally are not cleared by the operation described above. When ALL or SPOT is selected, the stored compensation values can be used.

## 6.2 Short Circuit Compensation

With short circuit compensation, it is possible to reduce the influence of the residual impedance of the test cables and thereby to enhance the accuracy of measurement.

It is effective for test samples whose impedance is relatively low.

The comparator decision mode can be set as one of the following:

### All Compensation

Compensation values are obtained for all test frequencies. (p.138)  
You can set the range of measurement frequencies to correct. (p.129)

### Spot Compensation

Compensation values are obtained at the set measurement frequency only. (p.140)

### OFF

Short circuit compensation data becomes invalid. (p.144)

### **NOTE**

- Before short circuit compensation, always set the cable length.  
**See** "6.4 Compensating Measurement Cable Errors(Cable Length Compensation)" (p. 157)
- The measurement accuracy values defined in the specifications are for when open circuit compensation and short circuit compensation are performed.
- Be sure to perform compensation again after replacing the measuring cable.  
You will be unable to obtain correct values if measurement is performed in the compensation state prior to replacement.
- For SPOT compensation, the open circuit compensation will be valid only when the measurement frequency agrees with the SPOT compensation frequency.
- When performing compensation, make sure that there is no noise source nearby. Noise may cause an error when performing compensation.  
ex. Servo Motor, switching power source, high-voltage cable and etc.
- The compensation process should be performed under conditions similar to those in which the sample will be measured.
- The compensated value is preserved in the memory of the main instrument even when power is turned off.
- Compensation values cannot be acquired with the continuous measurement mode. The **ADJ** key is disabled.

**Before Performing Screen Operations**

Necessary item: Shorting bar

This shorting bar is for short circuiting together the ends of the test leads. Use an object whose impedance is as low as possible.

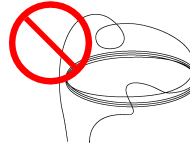
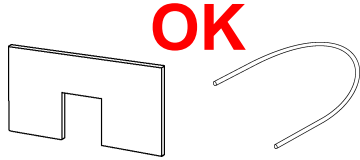

If you use a metallic wire or the like as a shorting bar, try to ensure that it is as thick and short as possible.

Usage example:

Arrange the test leads as closely as possible to their configuration in which measurement will be performed, and short circuit together the HIGH and LOW leads.

(When using the optional 9140-10)

If you intend to short circuit between the clamps at the ends of the test leads, clip both clamps onto a short piece of metallic wire as shown.

When using the 9140-10, please pinch the short wire with both clips. A short circuit state can not be created by pinching clip each other.

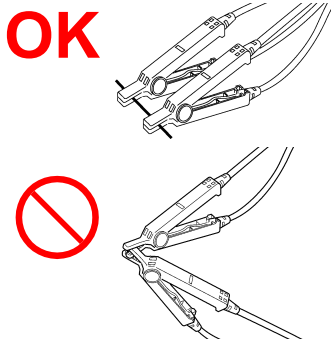

(When using the optional L2000)

Align the "V" marks on the clips as shown below and short the terminals.

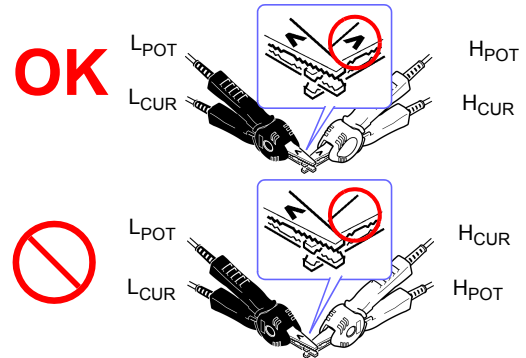

(When using a fixture)

In order to keep external influences as low as possible, be sure to thrust the shorting bar in all the way.

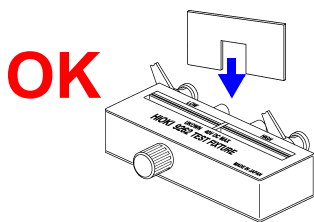

(When using the optional 9500-10)

Pinch the clips onto a short metallic wire in the order of H<sub>CUR</sub>, H<sub>POT</sub>, L<sub>POT</sub>, and L<sub>CUR</sub> so that all the terminals are shorted, and then perform open correction.

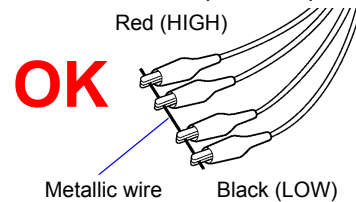

## 6.2 Short Circuit Compensation

### 6.2.1 All Compensation

Simultaneously acquire the short compensation values for all measurement frequencies.

When limiting the frequency range for ALL compensation

See "Compensation range limit function" (p.129)

- 1 Press the **ADJ** key while the Measurement screen is displayed to display the Adjust screen.

**NOTE**

The **ADJ** key cannot be used on screens other than the Measurement screen.

- 2 Select **[SHORT]** on the Adjust screen.

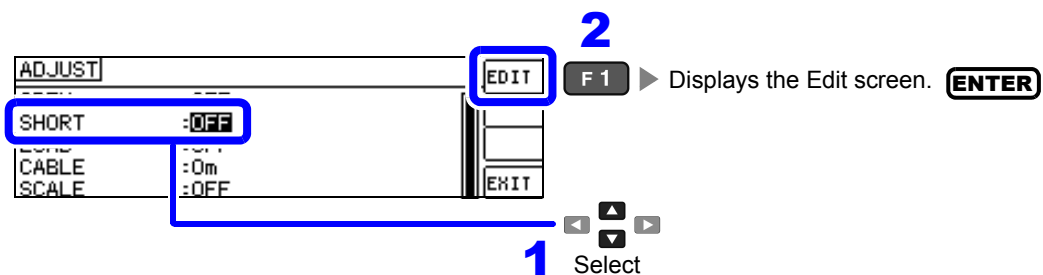

- 3 Select **[TYPE]** on the short compensation Edit screen.

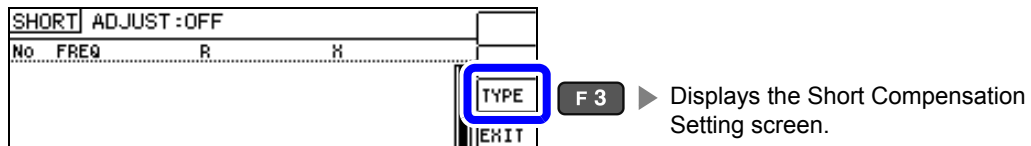

- 4 Select **[ALL]**.

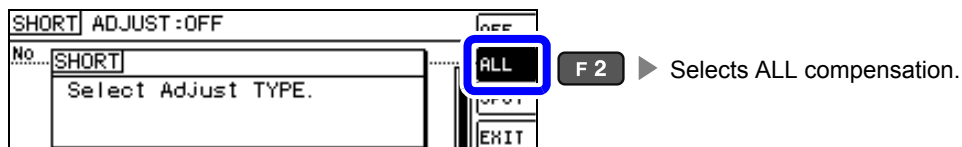

- 5

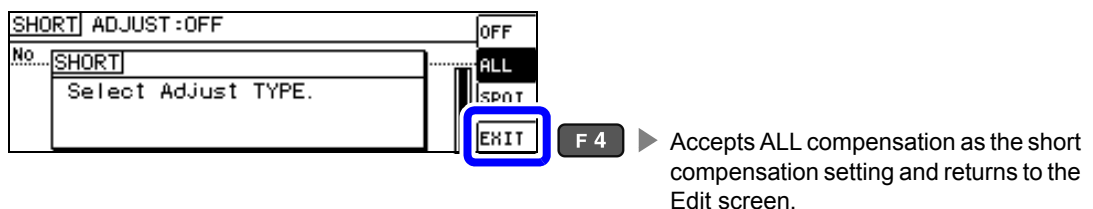



## 6 Select [EXEC].

No	FREQ	R	X
01	DC	0.00m $\Omega$	0.00m $\Omega$
02	40.000 Hz	0.00m $\Omega$	0.00m $\Omega$
03	99.999 Hz	0.00m $\Omega$	0.00m $\Omega$
04	100.00 Hz	0.00m $\Omega$	0.00m $\Omega$

[EXEC] F 1 ▶ Performs short compensation.  
 [AREA] F 2 ▶ Limits the compensation range. (p.129)  
 [EXIT] F 4 ▶ Cancels acquisition of compensation values and returns to the Adjust screen, leaving the previous compensation values enabled.

- NOTE**
- The previous compensation values will be displayed on the confirmation screen. (If compensation has never been performed, 0 will be used as the compensation value.)
  - Verify that the measurement cables have been shorted.

## 7 Short compensation is performed. Compensation time: Approx. 45 seconds.

No	FREQ	R	X
01	DC	0.00m $\Omega$	0.00m $\Omega$
02	40.000 Hz	0.00m $\Omega$	0.00m $\Omega$
03	99.999 Hz	0.00m $\Omega$	0.00m $\Omega$
04	100.00 Hz	0.00m $\Omega$	0.00m $\Omega$

[CANCL] F 4 ▶ Cancels short compensation and closes the window. (The previous short compensation values will be used.)

## 8 Check the open compensation results.

Compensation no.      Measurement frequency      Compensation results (effective resistance, reactance)

You can check the effective resistance and reactance at compensation points with .

No	FREQ	R	X
01	DC	24.41m $\Omega$	0.00m $\Omega$
02	40.000 Hz	12.77m $\Omega$	-0.07m $\Omega$
03	99.999 Hz	-61.11m $\Omega$	0.08m $\Omega$
04	100.00 Hz	21.39m $\Omega$	-0.03m $\Omega$

When compensation completes normally, the effective resistance and reactance will be displayed. Compensation is supported for impedance values of 1 k $\Omega$  or greater.

- When normal compensation values were not acquired
  - If compensation failed
  - When you want to make short circuit compensation data invalid
- See (p.143)

## 9

No	FREQ	R	X
01	DC	24.41m $\Omega$	0.00m $\Omega$
02	40.000 Hz	12.77m $\Omega$	-0.07m $\Omega$
03	99.999 Hz	-61.11m $\Omega$	0.08m $\Omega$
04	100.00 Hz	21.39m $\Omega$	-0.03m $\Omega$

[EXIT] F 4 ▶ Returns to the Adjust screen.

## 6.2.2 Spot Compensation

In SPOT compensation, compensation values are obtained for the set measurement frequencies. Up to five points can be set for measurement frequencies.

- 1 Press the **ADJ** key while the Measurement screen is displayed to display the Adjust screen.

**NOTE**

The **ADJ** key cannot be used on screens other than the Measurement screen.

- 2 Select **[SHORT]** on the Adjust screen.

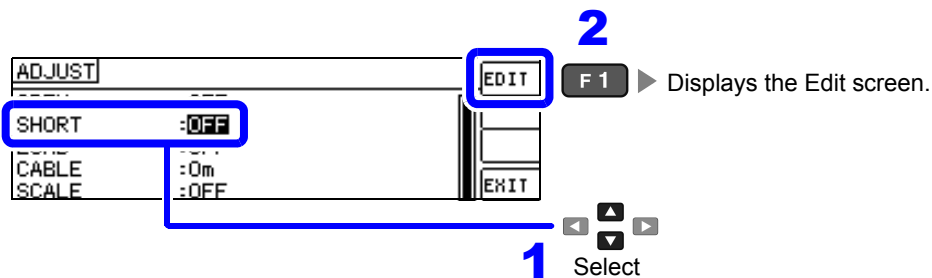

- 3 Select **[TYPE]** on the short compensation Edit screen.

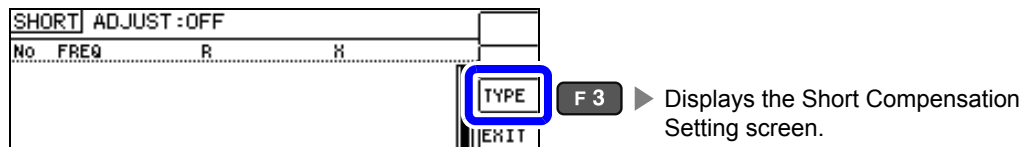

- 4 Select **[SPOT]**.

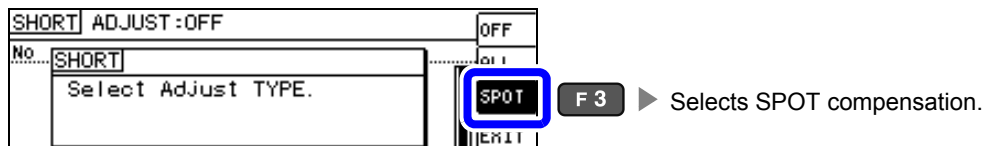

- 5

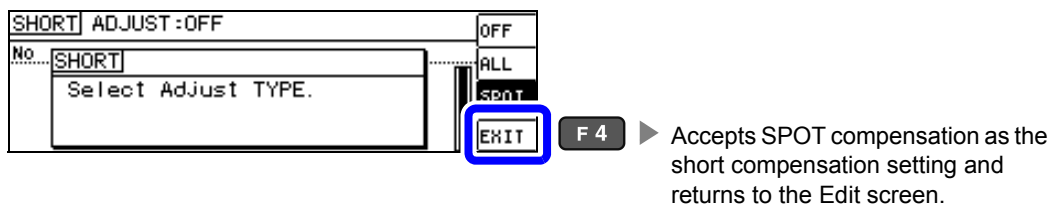

- 6 Select the compensation points you wish to set.

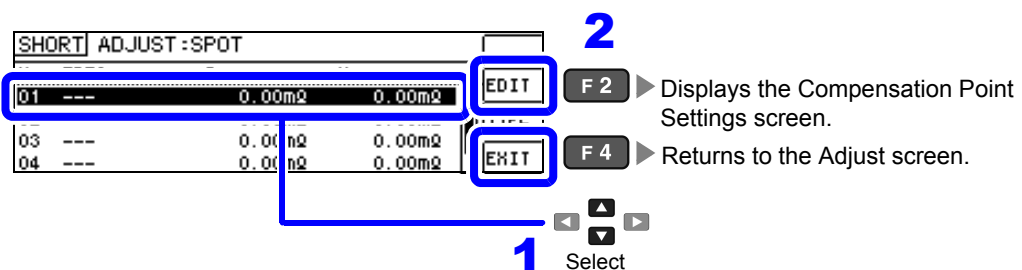

**7** Enter the frequency to correct.

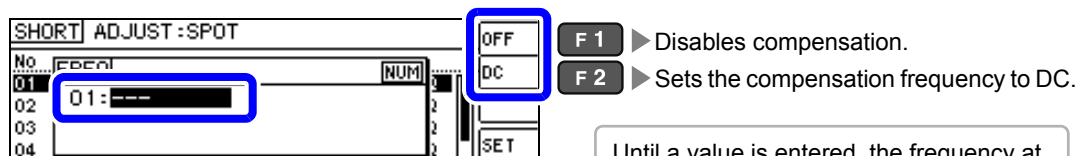

Until a value is entered, the frequency at which spot compensation was previously performed is displayed.

**8** Enter a value with the tenkey and accept it with the **ENTER** key. **10KEY**

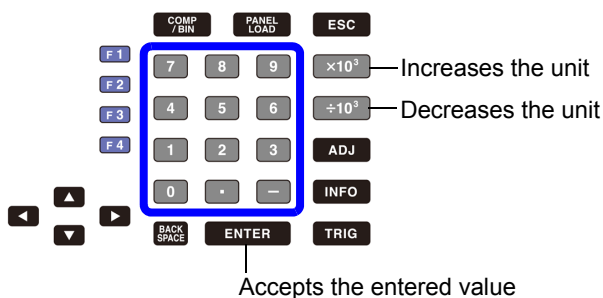

If you make a mistake:  
Press **BACK SPACE** key and reenter the value.

- Settable range: DC, 40 Hz to 200 kHz
- If you set a frequency in excess of 200 kHz, the frequency will automatically revert to 200 kHz.
- If a frequency of less than 40 Hz is set, the value will be automatically changed to 40 Hz. However, very small values will cause the DC setting to be used.

**9**

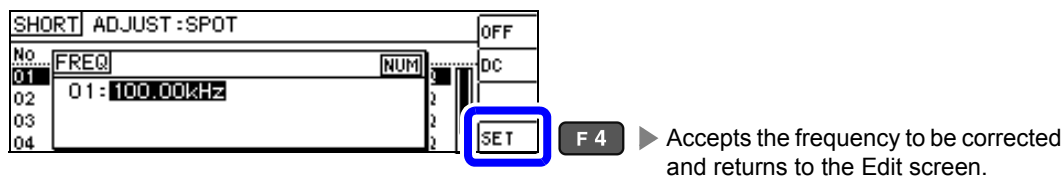

**10** Select **[EXEC]**.

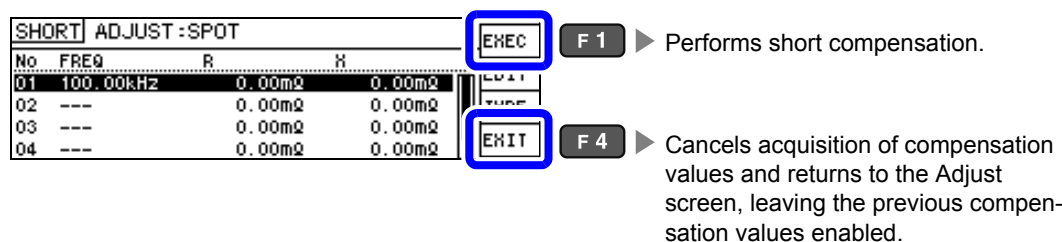

- NOTE**
- The previous compensation values will be displayed on the confirmation screen. (If compensation has never been performed, 0 will be used as the compensation value.)
  - Verify that the measurement cables have been shorted.

## 6.2 Short Circuit Compensation

### 11

Short compensation is performed.

The time required to perform the compensation process varies with the measurement frequency and number of points.

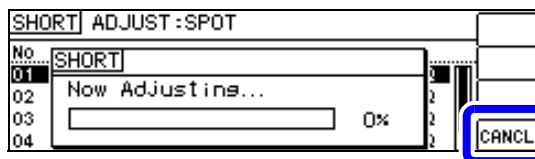

**F 4** ► Cancels short compensation and closes the window.  
(The previous short compensation values will be used.)

### 12

Check the short compensation results.

Compensation no.      Measurement frequency      Compensation results (effective resistance, reactance)

No	FREQ	R	H
01	100.00kHz	28.51mΩ	-0.07mΩ
02	---	0.00mΩ	0.00mΩ
03	---	0.00mΩ	0.00mΩ
04	---	0.00mΩ	0.00mΩ

You can check the effective resistance and reactance at compensation points with .

When compensation completes normally, the effective resistance and reactance will be displayed. Compensation is supported for impedance values of 1 kΩ or greater.

- When normal compensation values were not acquired
- If compensation failed
- When you want to make short circuit compensation data invalid

See (p.143)

### 13

No	FREQ	R	H
01	100.00kHz	28.51mΩ	-0.07mΩ
02	---	0.00mΩ	0.00mΩ
03	---	0.00mΩ	0.00mΩ
04	---	0.00mΩ	0.00mΩ

**F 4** ► Returns to the Adjust screen.

## When Normal Compensation Values were Not Acquired

If the following error is encountered when compensation completes, you can press **EXIT** to enable the acquired compensation values. However, the accuracy of those values is not guaranteed.

Screen when the instrument is unable to acquire normal compensation values

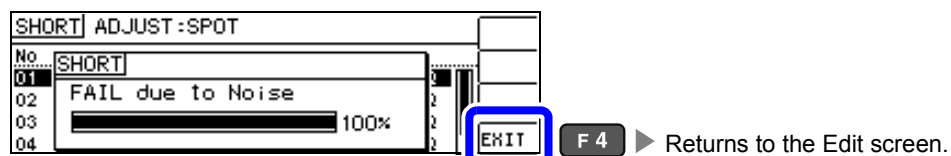

Check the following points before starting the short circuit compensation process again (p.136):

- Check that the test cables are properly connected.
- Check that the test cables are properly shorted together with the shorting bar. (Short circuit compensation cannot be performed while any test sample is connected to the test cables.)
- Check that the test leads are arranged as closely as possible to their configuration in which measurement will be performed.
- During the compensation process, be sure not to disturb the test cables or to move your hand near them.

## When Short Compensation Failed

A window such as the following will be displayed if compensation fails.

When an error message appears and compensation has stopped (when **EXIT** is pressed), the instrument conditions revert to those before the compensation was attempted to be performed.

Screen when compensation fails

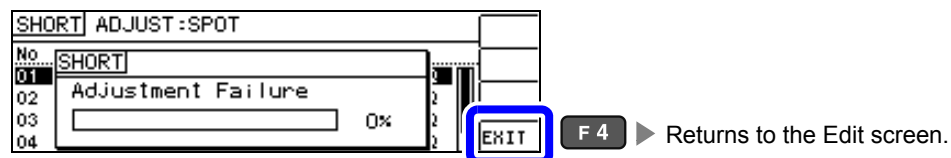

Check the following points before starting the short circuit compensation process again (p.136):

- Check that the test cables are properly connected.
- Check that the test cables are properly shorted together with the shorting bar. (Short circuit compensation cannot be performed while any test sample is connected to the test cables.)
- Check that the test leads are arranged as closely as possible to their configuration in which measurement will be performed.
- During the compensation process, be sure not to disturb the test cables or to move your hand near them.

## 6.2 Short Circuit Compensation

### When You Want to Make Short Circuit Compensation Data Invalid

You can invalidate the acquired compensation data and return to the Measurement screen by pressing **OFF** and then **EXIT** ( **F 4** ) in step 4 of the ALL compensation procedure (p.138) or the SPOT compensation procedure (p.140) for short compensation.

#### Short Compensation Settings

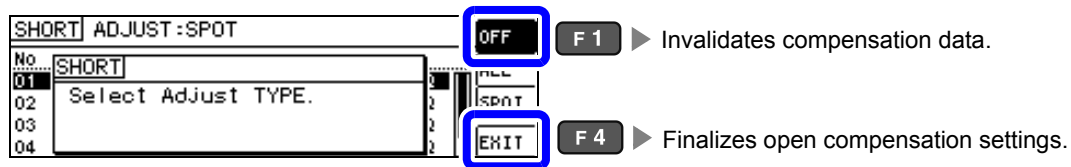

**NOTE** Performing the operation described above will not delete compensation values stored in the instrument's memory. The saved compensation values will be used when ALL or SPOT is selected.

## 6.3 Adjusting Values Based on Reference Values(Load Compensation)

Compensate measurement values to match the element that will be the reference.

With load compensation it is possible to calculate the compensation coefficient by measuring a reference sample with known data and perform the compensation for the test data obtained from the target sample. This function provides the compatibility with the test data.

You can acquire compensation coefficients for up to five sets of compensation conditions. Reference values can be set independently for each set of compensation conditions.

The following six items should be set for one compensation condition.

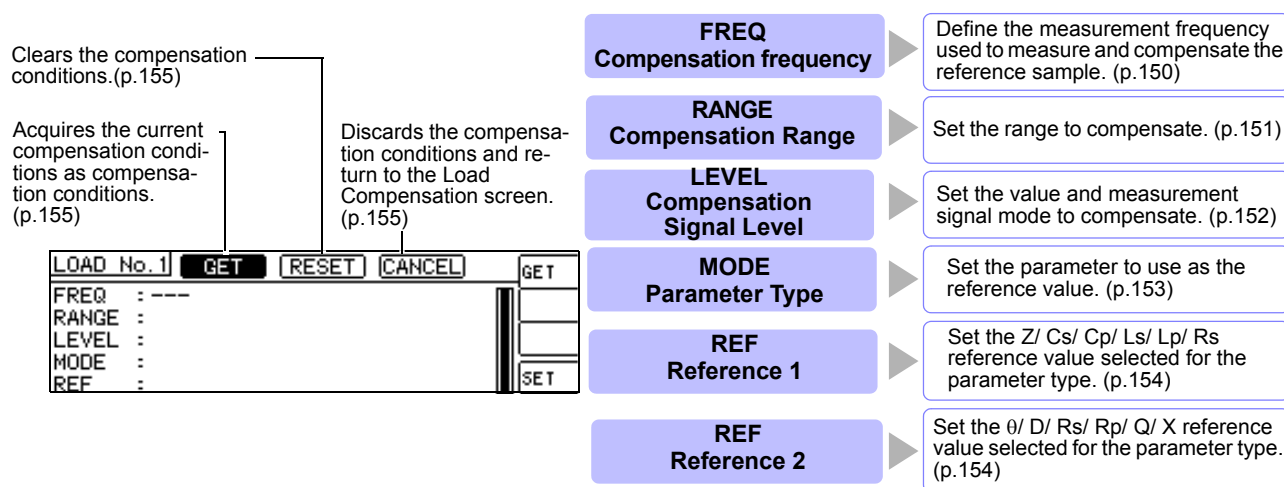

The compensation coefficient is computed from the reference values of Z and  $\theta$  obtained from the set values and the actual data acquired from the reference sample at each of the compensation frequencies.

$$\text{Compensation coefficient of Z} = \frac{(\text{Reference value of Z})}{(\text{Actual data of Z})}$$

$$\text{Compensation value of } \theta = (\text{Reference value of } \theta) - (\text{Actual data of } \theta)$$

The measured values of Z and  $\theta$  are first compensated using the following equations, and then individual parameters from the compensated Z and  $\theta$  values are employed.

$$Z = (Z \text{ before compensation}) \times (\text{Compensation coefficient of Z})$$

$$\theta = (\theta \text{ before compensation}) + (\text{Compensation value of } \theta)$$

## 6.3 Adjusting Values Based on Reference Values(Load Compensation)

- NOTE**
- Be sure to set the cable length before performing load compensation.
  - See "6.4 Compensating Measurement Cable Errors(Cable Length Compensation)" (p. 157)
  - Set the compensation condition of the load compensation same as the present measurement condition. If they do not match, no load compensations are performed.
  - If the current measurement frequency does not match the compensation frequency, an error such as the following will be displayed on the Info screen.

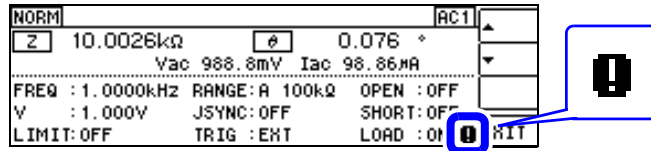

- If conditions other than the compensation frequency match, compensation will be performed, and an error such as the following will be displayed on the Info screen.

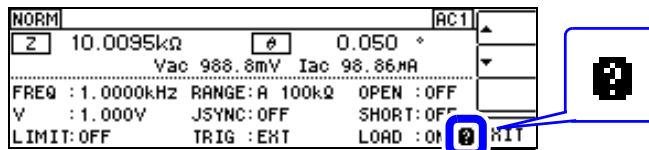

- When the OPEN or SHORT compensation is valid, the load compensation is performed for Z and  $\theta$  processed by the OPEN or SHORT compensation.
- In acquiring load compensation data (i.e., reference sample measurement), the OPEN/SHORT compensation settings, that were defined before entry into the Load Compensation Screen, are valid.
- If the same compensation frequency is set for multiple compensation points, only the compensation point with the lowest number of the compensation conditions will become effective.

- 1 Press the **ADJ** key while the Measurement screen is displayed to display the Adjust screen.

**NOTE** The **ADJ** key cannot be used on screens other than the Measurement screen.

- 2 Select **[LOAD]** on the Adjust screen.

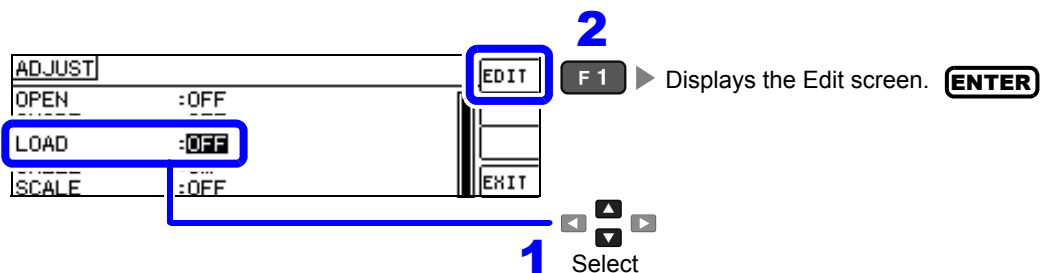

- 3 Select **[TYPE]** on the load compensation Edit screen.

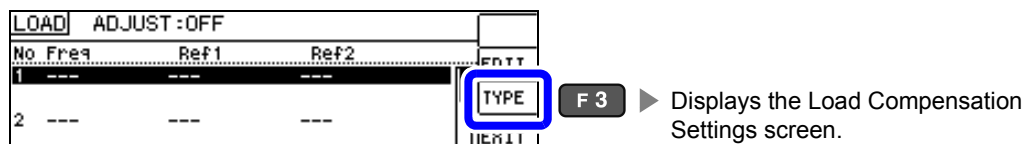

- 4 Select **[ON]** for the load compensation setting.

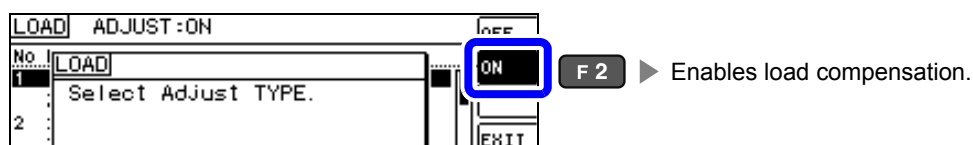



### 6.3 Adjusting Values Based on Reference Values(Load Compensation)

5

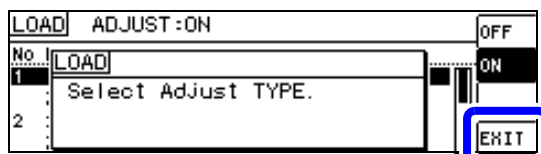

► Enables load compensation and returns to the Edit screen.

6

Select the load compensation condition number you wish to configure and select [EDIT].

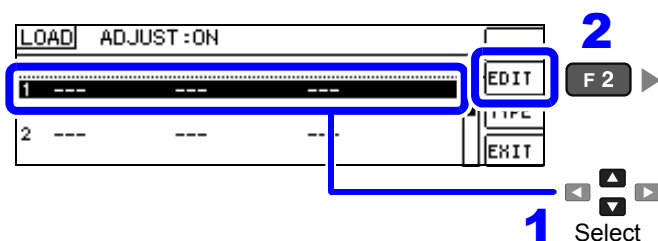

► Displays the load compensation conditions Edit screen.

7

Set the load compensation conditions.



For more information about how to configure each setting, see the pages listed below.

Compensation condition	Page
FREQ (Compensation frequency)	(p.150)
RANGE (Compensation Range)	(p.151)
LEVEL (compensation level measurement signal mode and value)	(p.152)
MODE (parameter to use as refer- ence value)	(p.153)
REF(Reference value)	(p.154)

#### NOTE

- Configure settings in the following order: FREQ, RANGE, LEVEL, MODE, REF.
- If the settings have not all been configured, you will not be able to perform compensation.
- If you want to use the current measurement conditions as the load compensation conditions(p.155).

## 6.3 Adjusting Values Based on Reference Values(Load Compensation)

**8** Accept the load compensation conditions.

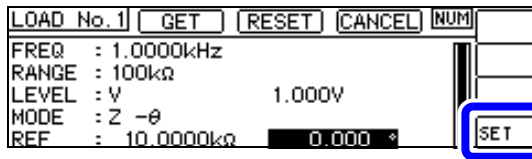

**F 4** ▶ Accepts the compensation conditions and returns to the load compensation Edit screen.

Either place a standard sample on the fixture or connect the sample to the measurement cables.

### Resetting or canceling the set conditions

Select **[RESET]** with the ◀ ▶ keys and press **F1** key to reset the set conditions. (p.155)  
 Select **[CANCEL]** with the ◀ ▶ keys and press **F1** key to return to the Edit screen. (p.155)

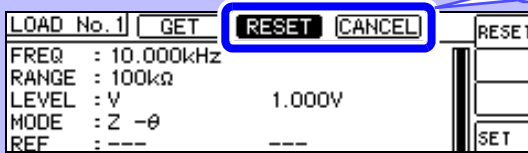

**9** Select **[EXEC]** to acquire compensation values.

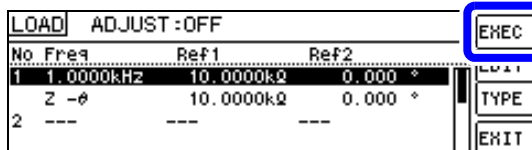

**F 1** ▶ Acquires compensation values.

- Changing any of the compensation conditions after acquiring compensation data will invalidate the compensation data.
- If an error occurs during the acquisition of compensation data, the instrument will beep, and the compensation data will be invalidated. (p.155)
- Changing any of the compensation conditions after acquiring compensation data will invalidate the compensation data.

**10** Load compensation will be performed.

The time required to perform the compensation process varies with the measurement frequency.

See "When Load Compensation Failed" (p.155)

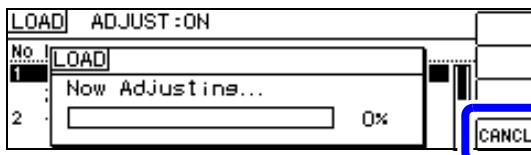

**F 4** ▶ Cancels the load compensation operation and returns to the Compensation screen. (The previous load compensation values will be used.)

6.3 Adjusting Values Based on Reference Values(Load Compensation)

11 Check the load compensation results.

LOAD ADJUST:ON			EXEC	
No	Freq	Ref1	Ref2	EDIT
1	---	---	---	---
2	- $\theta$	10.0048k $\Omega$	0.076 *	---
3	---	---	---	---
			EXIT	

The compensation values will be displayed when the acquisition of compensation values completes.

12

LOAD ADJUST:ON			EXEC	
No	Freq	Ref1	Ref2	EDIT
1	1.0000kHz	10.0000k $\Omega$	0.000 *	---
2	- $\theta$	10.0048k $\Omega$	0.076 *	---
3	---	---	---	---
			EXIT	

F 4 Returns to the Adjust screen.

If multiple load compensation conditions have been set with the same compensation frequency, the compensation conditions with the lowest compensation condition number will take effect. If the current measurement frequency does not match the compensation frequency, load compensation will not be enabled (turned on).

Verifying load compensation

NORM		AC1	
Z	10.0030k $\Omega$	$\theta$	0.000 *
Vac 988.7mV Iac 98.79mA			
FREQ	: 1.0000kHz	RANGE:A 100k $\Omega$	OPEN :OFF
V	: 1.000V	JSYNC:OFF	
LIMIT:OFF	TRIG :EXT	LOAD :ON	EXIT

- When load compensation is enabled under the set measurement conditions, the LOAD parameter on the **INFO** measurement conditions will turn on.
- If multiple load compensation conditions have been set with the same compensation frequency, the compensation conditions with the lowest compensation condition number will take effect.
- If the current measurement frequency does not match the compensation frequency, load compensation will not be enabled (turned on).

## 6.3 Adjusting Values Based on Reference Values(Load Compensation)

### Setting the compensation frequency.

**1** Select [FREQ].

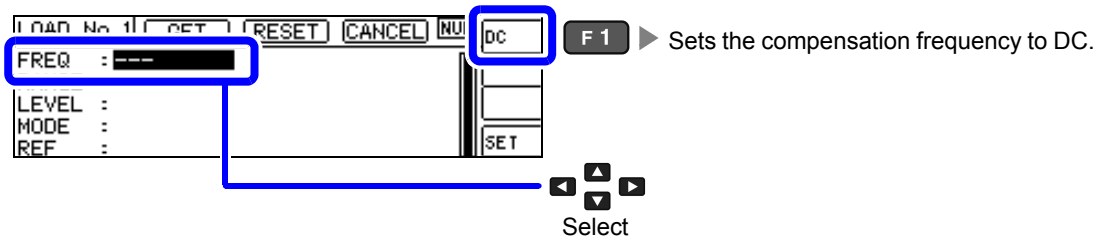

**2** Enter the frequency to correct. **10KEY**

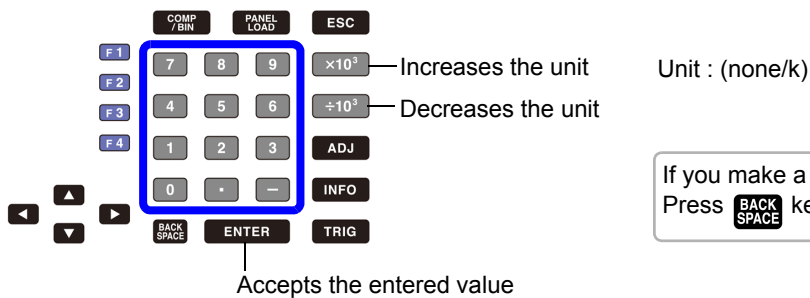

- Settable range:DC, 40 Hz to 200 kHz
- If you set a frequency in excess of 200 kHz, the frequency will automatically revert to 200 kHz.
- If a frequency of less than 40 Hz is set, the value will be automatically changed to 40 Hz. However, very small values will cause the DC setting to be used.

### 6.3 Adjusting Values Based on Reference Values(Load Compensation)

#### Setting the Compensation Range

**1** Select [RANGE].

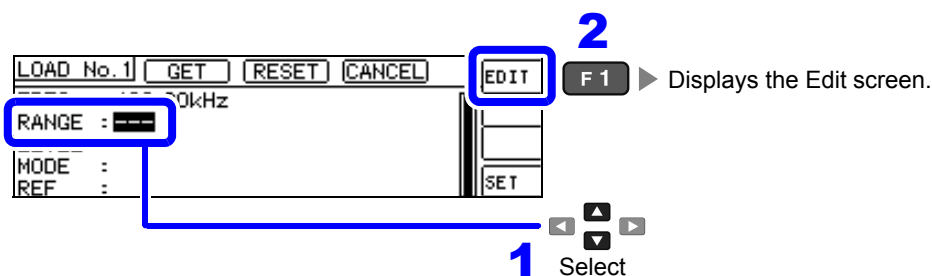

**2** Select the compensation range.

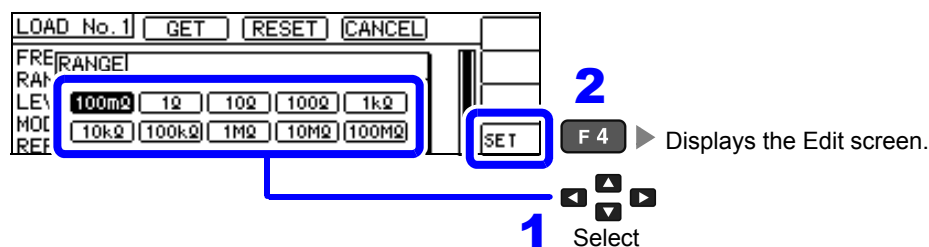

The ranges that can be selected vary with the frequency.

Frequency	Settable ranges	Range Setting screen
DC 40.000 Hz to 10.000 kHz	All range	
10.001 kHz to 100.00 kHz	100 mΩ to 10 MΩ	
100.01 kHz to 200.00 kHz	100 mΩ to 1 MΩ	

**NOTE** If the compensation frequency is not set, the compensation range cannot be set.

## 6.3 Adjusting Values Based on Reference Values(Load Compensation)

### Setting of Compensation signal level measurement signal mode and value

**1** Select the measurement signal mode.

**2**

- F 1 ▶ Open voltage (V) mode (p.39)
- F 2 ▶ Constant voltage (CV) mode (p.39)
- F 3 ▶ Constant current (CC) mode (p.39)

**1** Select

**2** Enter the compensation signal level voltage or current value. **DIGIT**

- F 1 ▶ Allows you to enter the voltage or current value.
- F 2 ▶ Selects the digit to change.

**1** Select

AC Load Compensation	
V, CV	0.005 V to 5.000 V
CC	0.01 mA to 50 mA

DC Load Compensation	
V	2 V (fixed)

- NOTE**
- If the compensation range is not set, you will not be able to set the compensation signal level measurement mode and value.
  - DC load compensation cannot be performed because the open voltage (V) mode is fixed to 2 V.

## 6.3 Adjusting Values Based on Reference Values(Load Compensation)

### Setting of Parameter to Use for Reference Value

1 Select [MODE].

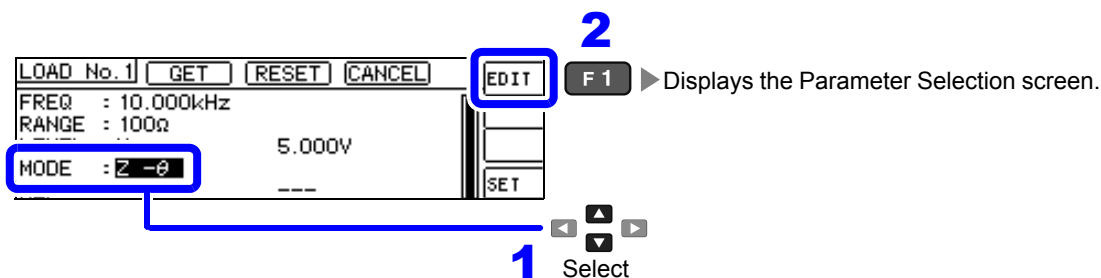

2 Select the parameter mode.

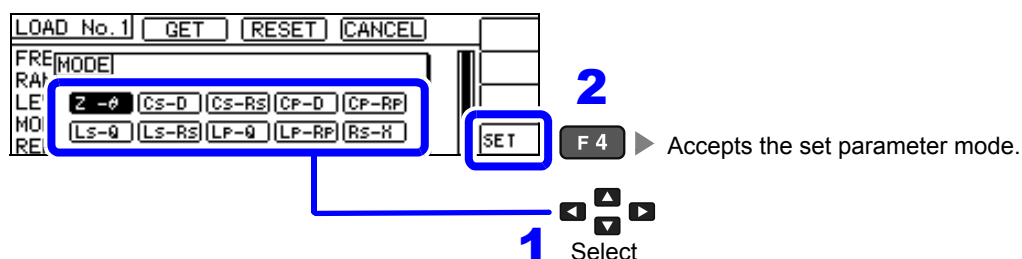

#### **NOTE**

- Failure to configure the compensation frequency, compensation range, and compensation signal level settings will prevent you from setting the parameter to use as a reference value.
- When DC is selected for the compensation frequency setting, DC resistance measurement (Rdc) mode will be selected automatically, and you will not be able to set the parameter to use as a reference value.
- Changing the parameter to use as a reference value clears the reference value 1 and reference value 2 settings.

6.3 Adjusting Values Based on Reference Values(Load Compensation)

Setting the Reference Value

1 Select the parameter reference value you wish to set under [REF].

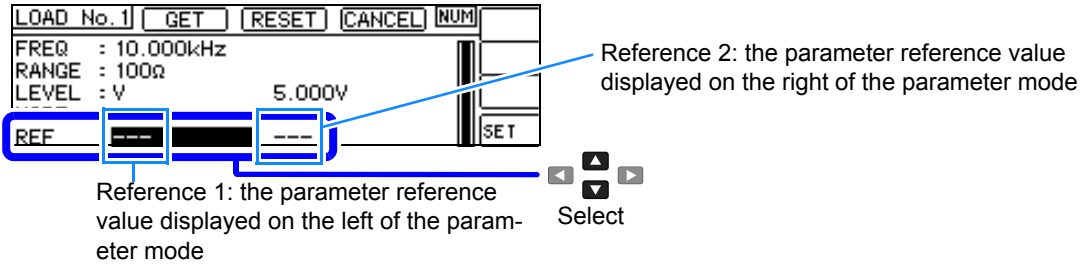

2 Enter the parameter reference values you wish to set and accept it with the **ENTER** key. **10KEY**

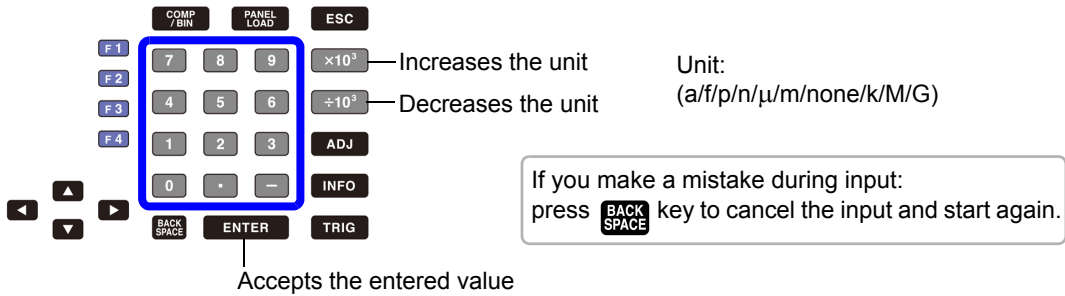

**NOTE**

- Failure to configure the compensation frequency, compensation range, and compensation signal level settings will prevent you from setting the parameter to use as a reference value.
- If you select DC as the compensation frequency setting, you will only be able to set reference value 1.



### 6.3 Adjusting Values Based on Reference Values(Load Compensation)

#### When You Want to Use the Current Measurement Conditions as the Load Compensation Conditions

By selecting [GET], you can acquire the current measurement conditions (frequency, range, measurement signal level measurement signal mode and value) as the load compensation conditions.

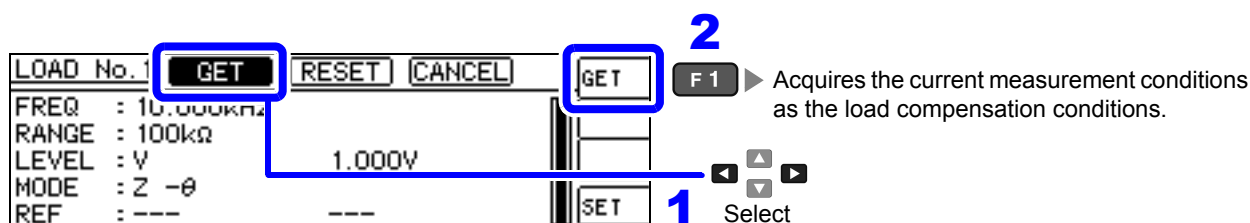

**NOTE** In the above example, loading the measurement conditions with GET causes MODE to be initialized to Z-θ.

#### When You Want to Reset All Settings

By selecting [RESET], you can clear all settings and start again from the compensation frequency setting.

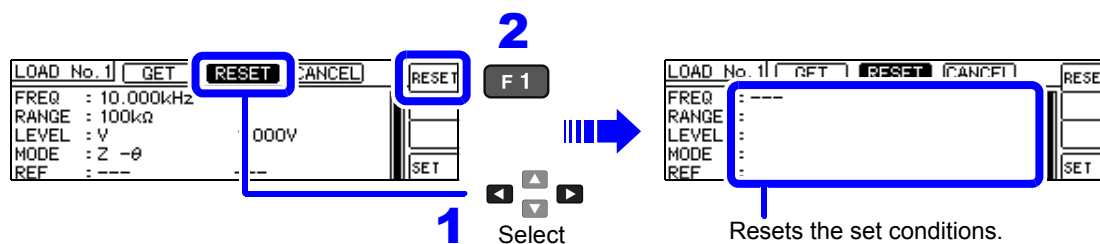

#### When you want to cancel the settings

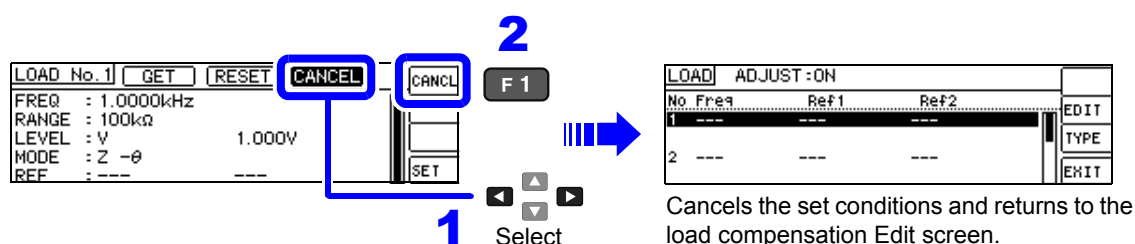

#### When Load Compensation Failed

When compensation fails, a window such as the following will be displayed.

Press [EXIT] to close the window and set the compensation condition once again.

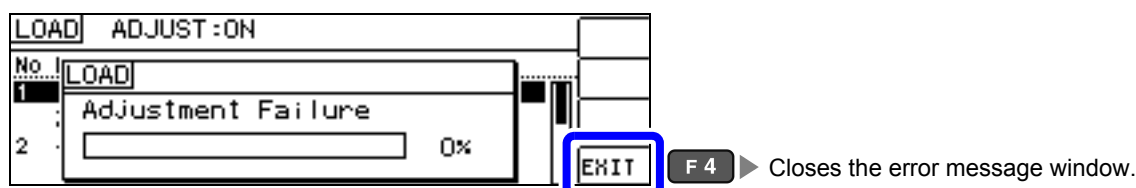

## 6.3 Adjusting Values Based on Reference Values(Load Compensation)

### Enabling/disabling load compensation

- 1 Press the **ADJ** key while the Measurement screen is displayed to display the Adjust screen.

**NOTE**

The **ADJ** key cannot be used on screens other than the Measurement screen.

- 2 Select **[LOAD]** on the Adjust screen.

The screenshot shows the ADJUST screen with the following options: ADJUST, OPEN :OFF, LOAD :OFF, and SCALE :OFF. The **LOAD** option is highlighted with a blue box. To the right, the **EDIT** key (F1) is highlighted with a blue box and labeled '2'. An arrow points from the EDIT key to the text 'Displays the Edit screen. ENTER'. Below the screen, a blue line connects the LOAD option to the '1 Select' label, indicating the selection process.

- 3 Select **[TYPE]** on the load compensation Edit screen.

The screenshot shows the LOAD ADJUST:OFF screen with a table of load compensation settings. The **TYPE** key (F3) is highlighted with a blue box and labeled '2'. An arrow points from the TYPE key to the text 'Displays the Load Compensation Setting screen.'. The table below shows the following data:

No	Freq	Ref1	Ref2
1	1.0000kHz	10.0000kΩ	0.000 °
2	-θ	10.0022kΩ	0.076 °
2	2.0000kHz	10.0000kΩ	0.000 °
2	-θ	10.0025kΩ	0.152 °

Below the screen, a blue line connects the TYPE option to the '1 Select' label, indicating the selection process.

- 4 Select **[ON]** or **[OFF]** for the load compensation setting.

The screenshot shows the LOAD ADJUST:ON screen with the text 'Select Adjust TYPE.' and two options: **OFF** (F1) and **ON** (F2). Both options are highlighted with blue boxes. Arrows point from the OFF key to 'Disables load compensation.' and from the ON key to 'Enables load compensation.'. Below the screen, a blue line connects the ON option to the '1 Select' label, indicating the selection process.

- 5

The screenshot shows the LOAD ADJUST:ON screen with the text 'Select Adjust TYPE.' and two options: **OFF** and **ON**. The **EXIT** key (F4) is highlighted with a blue box. An arrow points from the EXIT key to the text 'Enables the load compensation setting and returns to the Edit screen.'. Below the screen, a blue line connects the EXIT key to the '1 Select' label, indicating the selection process.

## 6.4 Compensating Measurement Cable Errors(Cable Length Compensation)

During high-frequency measurement, the measurement errors caused by the influence of cables increase in magnitude. You can reduce these errors by configuring the instrument with the length of the cable. Use coaxial cable with an impedance of 50  $\Omega$ .

- 1 Press the **ADJ** key while the Measurement screen is displayed to display the Adjust screen.

### NOTE

The **ADJ** key cannot be used on screens other than the Measurement screen.

- 2 Select **[CABLE]** and select the cable length.

2

F 1

F 2

Changes the cable length.

1

Select

0 m	Select when using a directly-connected fixture or similar setup.
1 m	Select when using a cable length of 1 m, 2 m, or 4 m.

- 3

EXIT

F 4

Returns to the Measurement screen.

### NOTE

- If the cable length changes, repeat open, short, and load compensation. The guaranteed accuracy range varies with the cable length. See "E Cable length coefficient" (p.208)
- When manufacturing your own cables, make sure that the cable length matches the length set with the instrument. (p.24)
- When using the L2000, set cable length compensation to 1 m.

## 6.5 Converting Values (Scaling)

Scaling applies a compensation function to the measurement value. This function can be used to provide compatibility among measurement devices.

In scaling, the user-specified compensation coefficients a and b are applied to main and sub parameter measurement values using the following formula.

See "Appendix1 Measurement Parameters and Calculation formula"(p. A1)

$$Y = a \times X + b$$

However, when the parameter corresponding to X is D or Q, its value is calculated based on  $\theta'$ , whose value is obtained by applying scaling to  $\theta$  with the following equation:

$$\theta' = a \times \theta + b$$

X : the first or third parameter measurement value

a : integration value of the measured value X

Y : the last measurement value

b : the value added to measured value X

$\theta'$  : compensation value of  $\theta$

- 1 Press the **ADJ** key while the Measurement screen is displayed to display the Adjust screen.

**NOTE**

The **ADJ** key cannot be used on screens other than the Measurement screen.

- 2 Select **[SCALE]** on the Adjust screen.

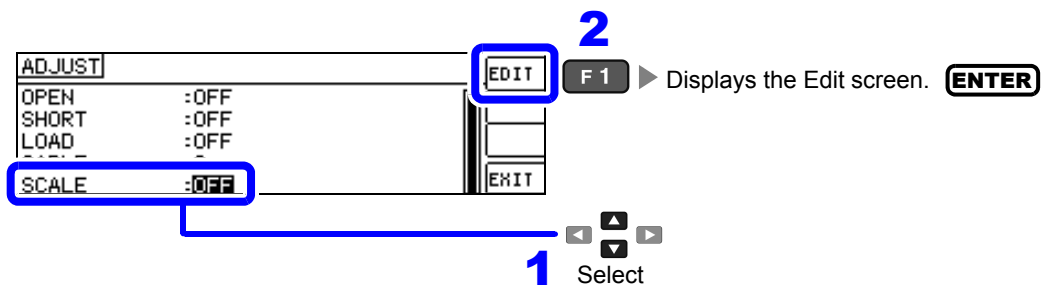

- 3 Select **[TYPE]** on the scaling Edit screen.

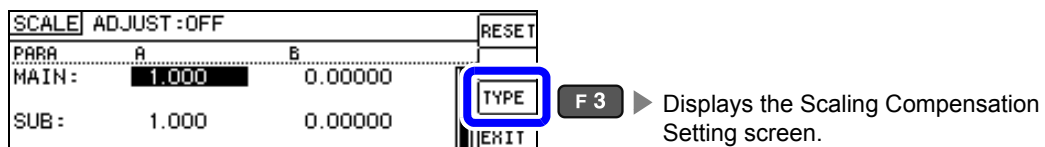

- 4 Turn the scaling compensation setting **[ON]** or **[OFF]**.

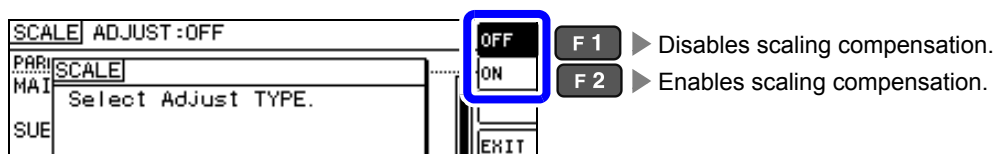

5

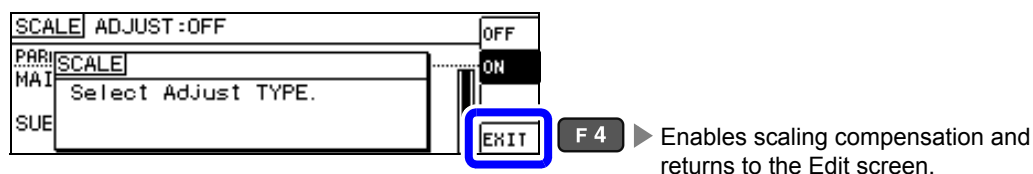

6

Select the parameter you wish to change (compensation coefficient A).

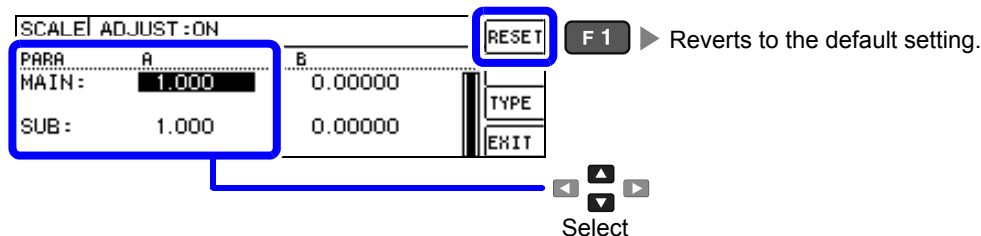

7

Enter a value for compensation coefficient A with the tenkey and accept it with the **ENTER** key. **10KEY**

Settable range:-999.999 to 999.999

Pressing ENTER while nothing is displayed will cause the instrument to return to the previous screen without changing the setting.

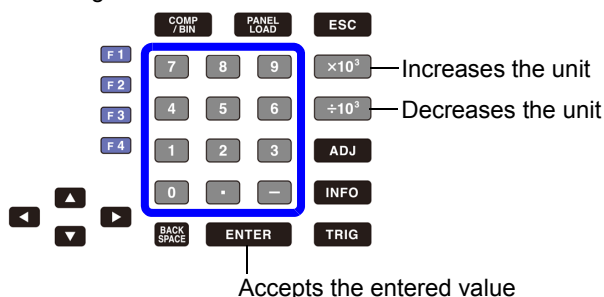
Unit:  
(a/f/p/n/ $\mu$ /m/none/k/M/G)If you make a mistake:  
Press **BACK SPACE** key and reenter the value.**NOTE**When entering a value for compensation coefficient A, the  $\times 10^3$   $\div 10^3$  keys are disabled.

8

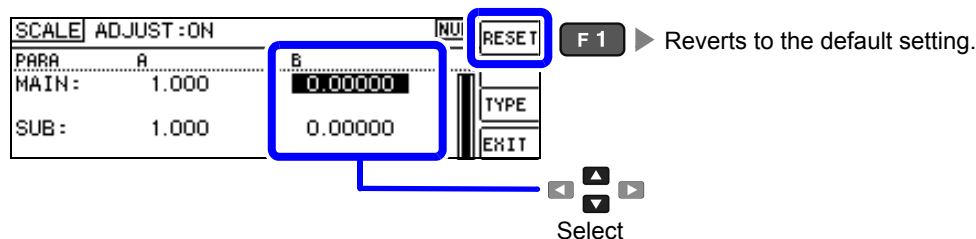
Enter a value for compensation coefficient B as you did for compensation coefficient A.  
Settable range:-9.99999 G to 9.99999 G

9

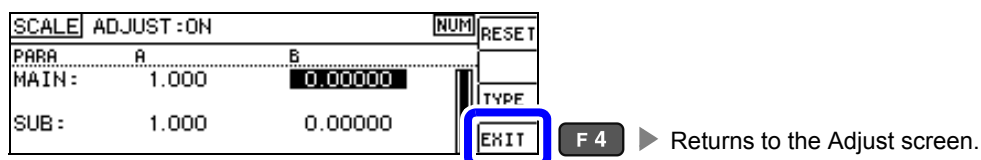
**NOTE** If you set the set the same parameter for the main and sub parameters with different compensation coefficients as shown below, scaling will be performed using the main parameter compensation coefficients. (The sub parameter compensation coefficients will be disabled.)

Display Parameter Setting	Compensation Coefficient Setting
MAIN Parameter:Z	a=1.500, b=1.50000
SUB Parameter:Z	a=1.700, b=2.50000



# Saving and Reading Panel Information Chapter 7

This chapter describes how to save to the instrument's internal memory and load data (measurement conditions and compensation values).

## Saving Data

- Measurement conditions and compensation values (p.162)

## Reading Data

- Measurement conditions and compensation values (p.165)

## Editing Saved Data

- Change panel name (p.167)
- Delete panel (p.169)

- NOTE**
- The instrument contains a built-in backup lithium battery , which offers a service life of about ten years.
  - When the life of the built-in battery ends, the measurement conditions will no longer be able to be saved. Submit a request for replacement of the battery to the Hioki repair service. (A fee will be charged.)(p.215)

## About the Save Screen

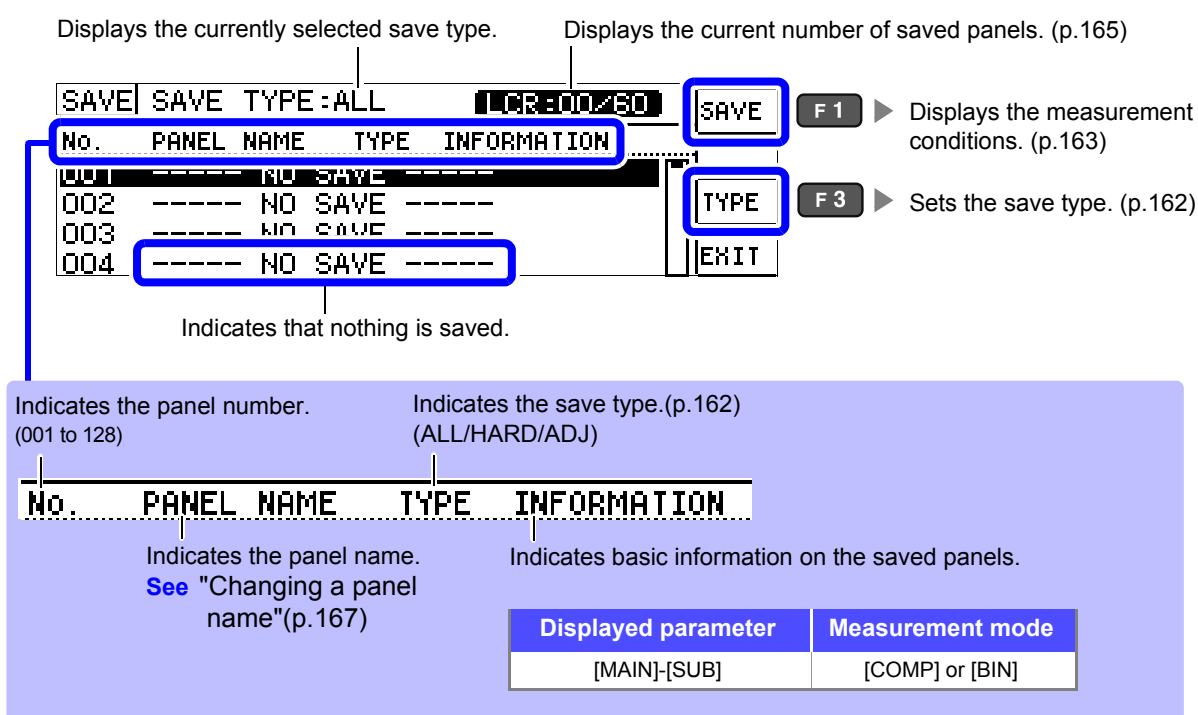

# 7.1 Saving Measurement Conditions (Panel Save Function)

You can save the measurement condition and compensation value. The number of items for which compensation can be performed is as follows:

- Measurement Condition ▶ Up to 60 items
- Compensation Value ▶ Up to 128 items

However, each of the measurement condition and compensation value is counted as one save data item when saved with **ALL**.

## Setting the Type to Save

**1** Open the Advanced Settings screen.

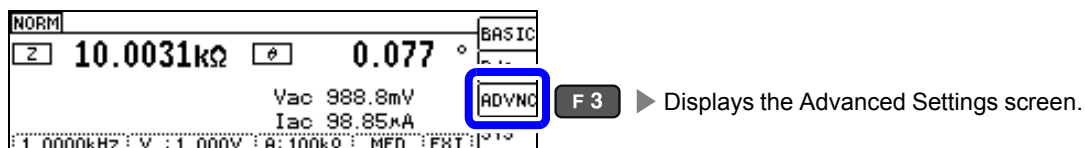

**2** Select the **[ADVANCED2]** tab.

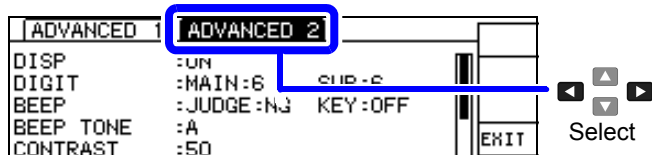

**3** Select **[PANEL SAVE]**.

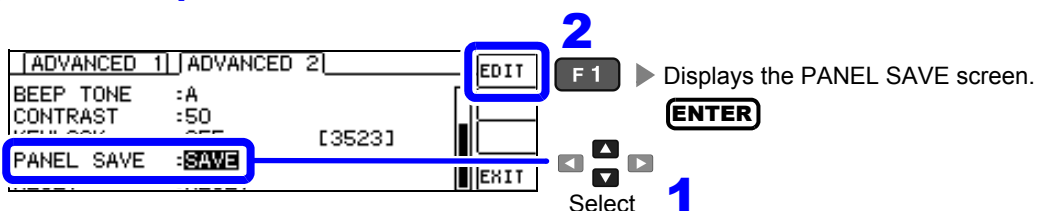

**4** Select **[TYPE]**.

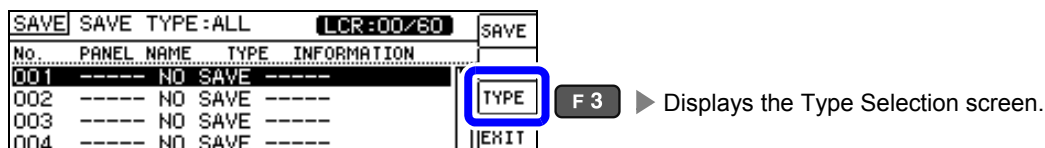

**5** Select the type of data to save.

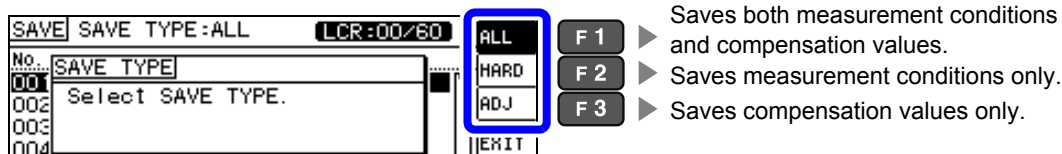

**6**

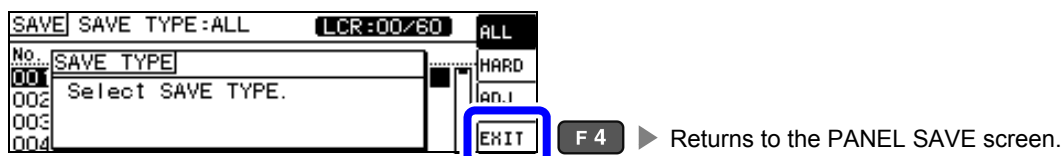



7.1 Saving Measurement Conditions (Panel Save Function)

Saving Measurement Conditions

- 1 Select the panel number to save.  
Display range: No.001 to No.128

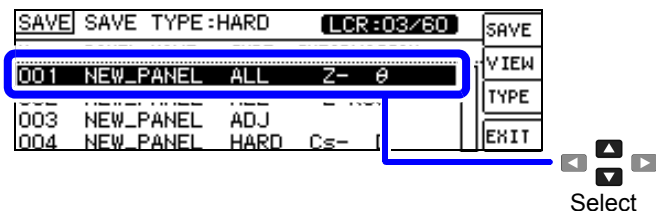

- 2 Select [SAVE].

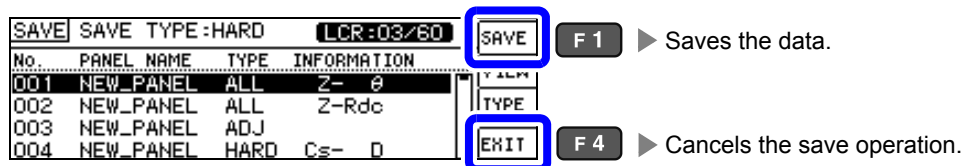

- 3 Save the panel.

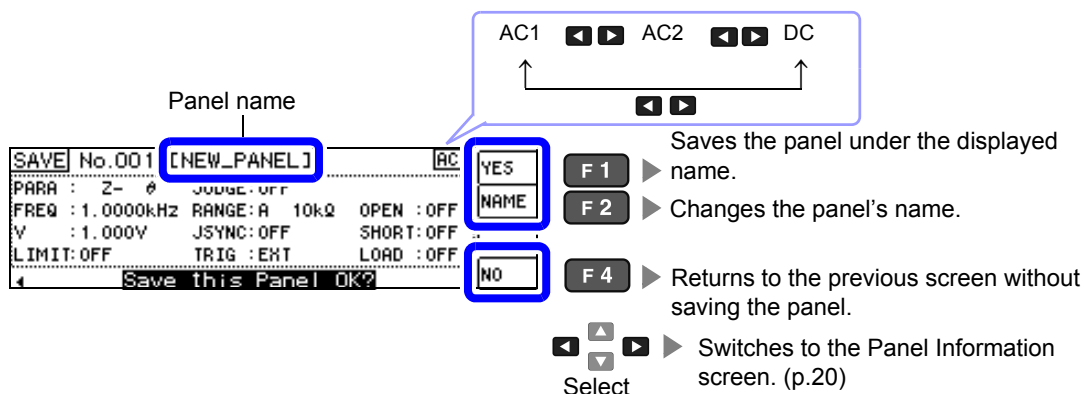

When [NAME] is selected

Changes the panel's name.

Enter a name for the panel (up to 10 characters).

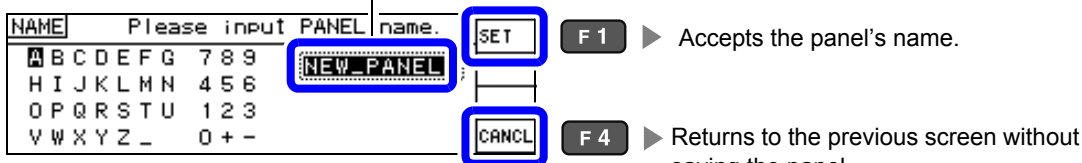

- If you make a mistake while entering the name:
  - Delete the previous character with **BACK SPACE** key.
  - The name will not be accepted until you press **ENTER** key.
- Selects a character.

**NOTE**

If you attempt to save the panel under the same name as a previously saved panel, a window confirming that you wish to overwrite the existing data will be displayed.

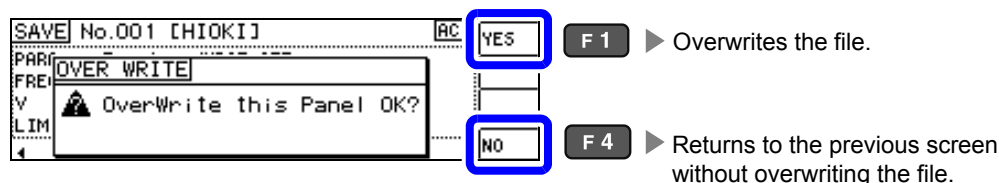



# 7.2 Reading Measurement Conditions (Panel Load Function)

You can read saved measurement conditions with the panel load function.

- 1 Press the **PANEL LOAD** key while the Measurement screen is displayed to display the PANEL LOAD screen.

**NOTE** The **PANEL LOAD** key cannot be used on screens other than the Measurement screen.

- 2 Select the number of the panel to load.  
Display range: No.001 to No.128

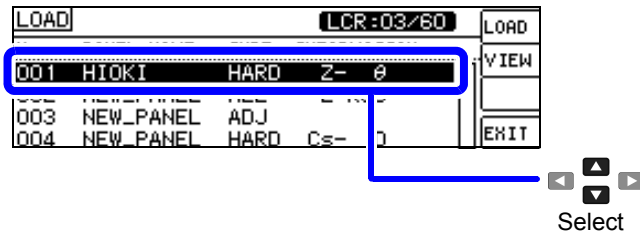

- 3 Load the measurement conditions for the selected panel number.

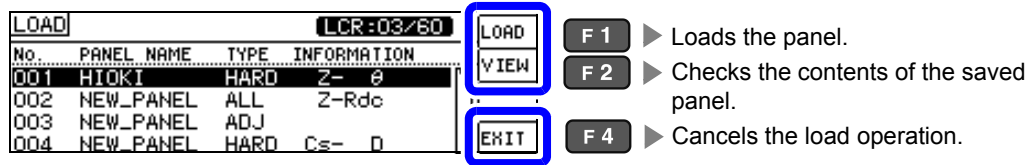

**When [VIEW] is selected**

You can check the contents of previously saved panels, delete panels, and change panel names.

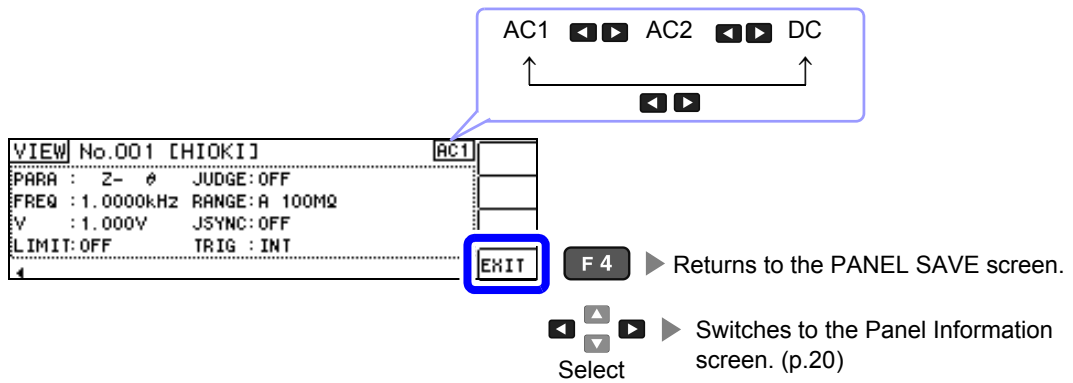

## 7.2 Reading Measurement Conditions (Panel Load Function)

**4** Load the panel.

AC1 ◀ ▶ AC2 ◀ ▶ DC  
◀ ▶

LOAD	No.001 [HIOKI]	AC	YES	F 1	▶
PARA :	Z- ∅	JUDGE:OFF			
FREQ :	1.0000kHz	RANGE:A 100MΩ			
V :	1.000V	JSYNC:OFF			
LIMIT:OFF		TRIG :INT			
	Load this Panel OK?				
			NO	F 4	▶

Loads the measurement conditions for the selected panel number. After loading the panel, automatically returns to the Measurement screen.

◀ ▶ Select ▶ Switches to the Panel Information screen. (p.20)

**5** Verify that the panel was loaded.

NOR	No.001				
Z	10.0051kΩ	∅	-0.012		
		Vac	1.068 V		
		Iac	106.8mA		
	1.0000kHz : V : 1.000V : R : 100kΩ : MED : INT :				

If the panel has been loaded, the loaded panel number will be displayed on the measurement screen.

# 7.3 Changing a Panel Name

You can change the name of a panel saved to the instrument.

- 1 Open the Advanced Settings screen.



- 2 Select the [ADVANCED2] tab.

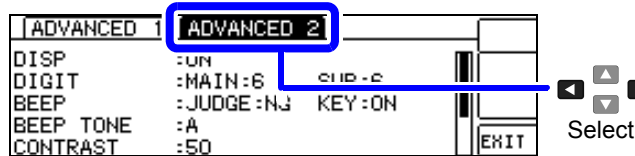

- 3 Select [PANEL SAVE].

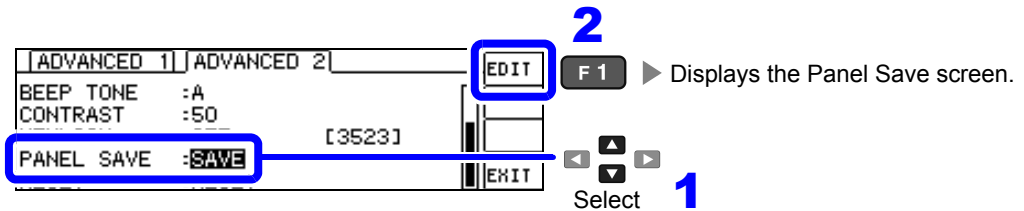

- 4 Select the panel whose name you wish to change.



- 5 Check the panel's contents and select [NAME].

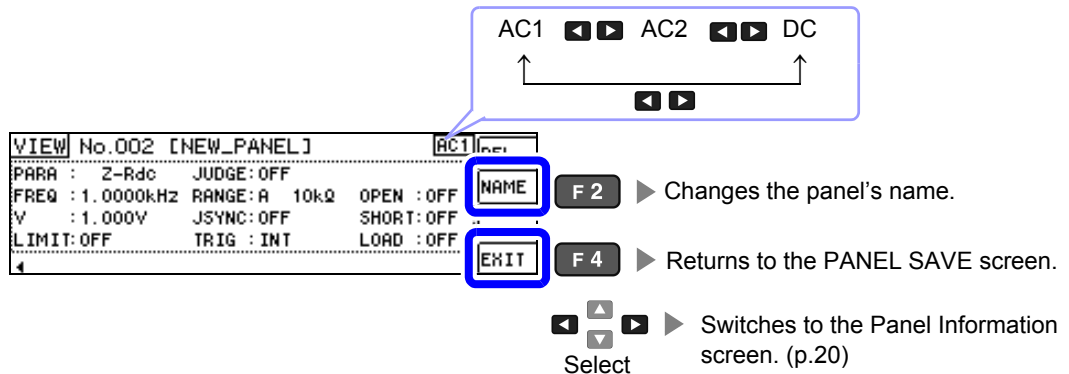

## 7.3 Changing a Panel Name

### 6 Change the panel's name.

Enter a name for the panel (up to 10 characters).

RENAME	Please input PANEL name.	SET	F 1	
	NEW PANEL			Changes the panel's name.
		CANCL	F 4	Cancels the change operation and returns to the previous screen.

- If you make a mistake while entering the name:
  - Delete the previous character with **BACK SPACE** key.
  - The name will not be accepted until you press **ENTER** key.

←
↑
→
↓
▶ Selects a character.

Select

### 7 The panel's name will be changed, and the saved contents will be displayed.

VIEW	No.002 [DATA_1]	ACT1	DEL	
			NAME	
	PARA : 2-FREQ JUDGE:OFF			
	FREQ : 1.0000kHz RANGE:A 10kΩ OPEN : OFF			
	V : 1.000V JSYNC:OFF SHORT: OFF			
	LIMIT:OFF TRIG :INT LOAD :OFF			
		EXIT	F 4	▶ Returns to the Panel Save screen.

# 7.4 Deleting a Panel

You can delete a panel saved to the instrument.

- 1 Open the Advanced Settings screen.

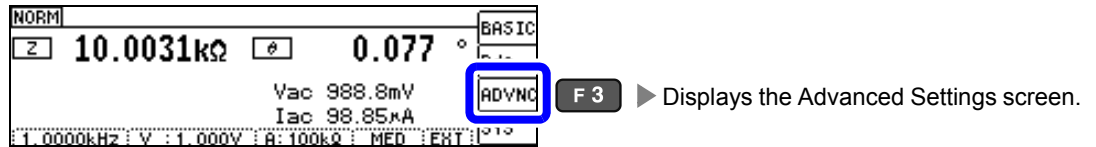

- 2 Select the [ADVANCED2] tab.

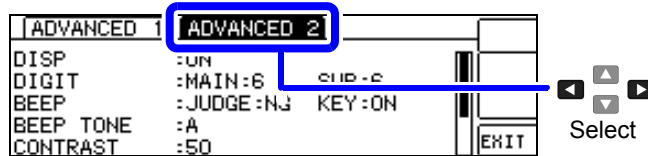

- 3 Select [PANEL SAVE].

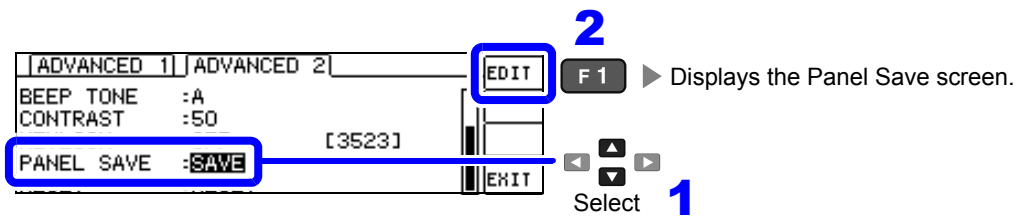

- 4 Select the panel you wish to delete.

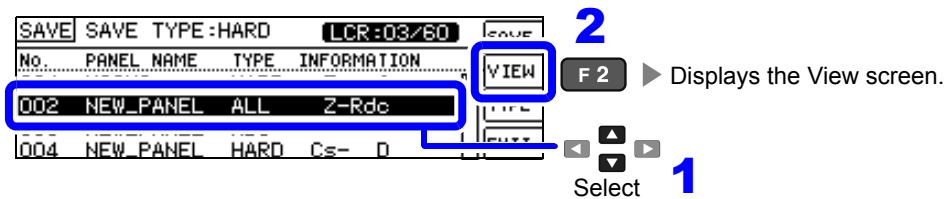

- 5 Check the panel's contents and select [DEL].

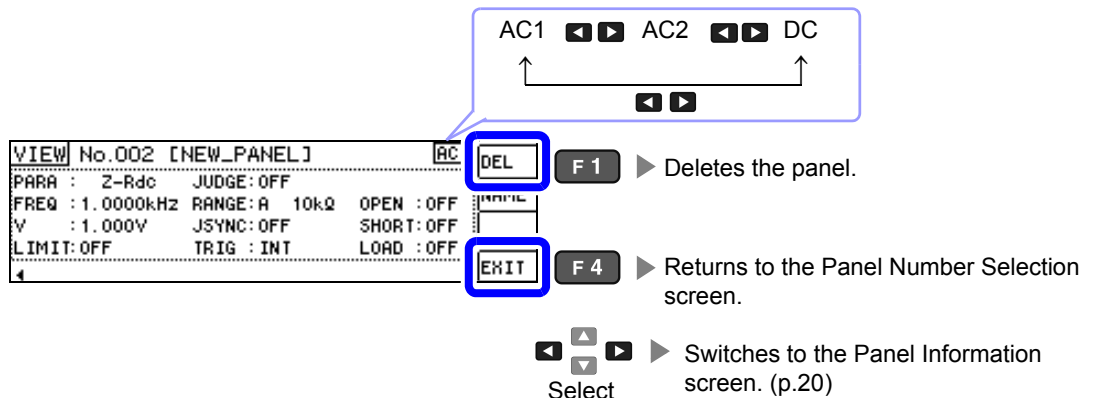

## 7.4 Deleting a Panel

---

**6** Select [YES] on the Delete Confirmation screen.

**F 1** ▶ Deletes the panel.

**F 4** ▶ Returns to the View screen without deleting the panel.

---

**7**

**F 4** ▶ Returns to the Advanced Settings screen.

---



# Setting the SYSTEM

## Chapter 8

### 8.1 Setting the Interface

You can control the instrument from a computer via the USB, GP-IB, RS-232C, and LAN interfaces. Printing can also be performed with an RS-232C printer.

- NOTE**
- Interface settings are available only when the Z3000 (GP-IB), Z3001 (RS-232C), or Z3002 (LAN) option is installed.
  - Printer settings are available only when the Z3001 is installed.

- 1 Open the System screen.

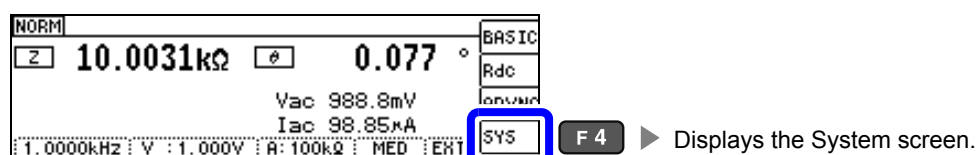

- 2 Select the [I/F] tab, and then select [KIND].  
The available interfaces are displayed. Select an interface to be used by pressing a corresponding F key. The display will vary with the installed option.

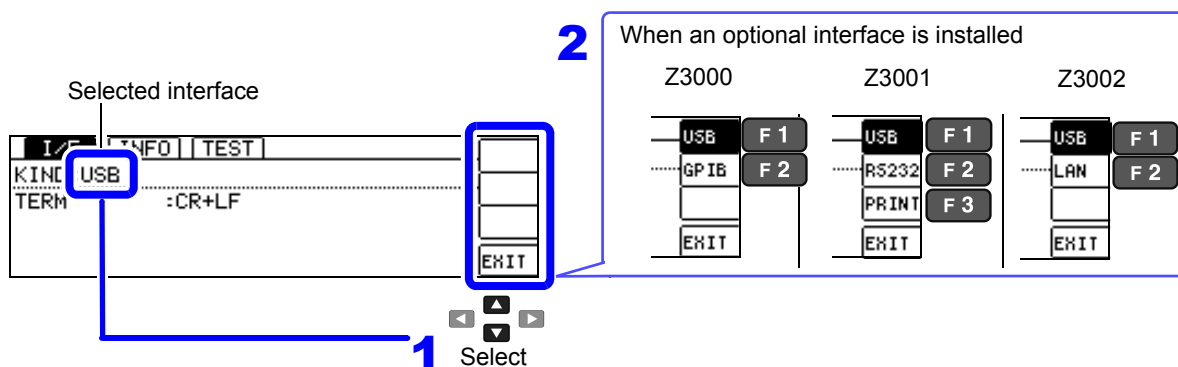

- NOTE**
- For more information about non-printer settings, see the Communication Instruction Manual (LCR Application Disk).
  - Printer settings  
See "10.2 Instrument and Printer Settings" (p. 197)

- 3
- 
- I/F INFO TEST
- KIND: USB
- TERM: -CR+LF
- EXIT F 4 ▶ Returns to the Measurement screen.

## 8.2 Checking the Version of the Instrument

- 1** Open the System screen.

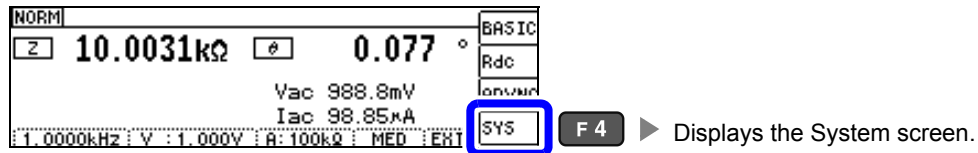

- 2** Select [INFO] and check the device information.(p. 18)

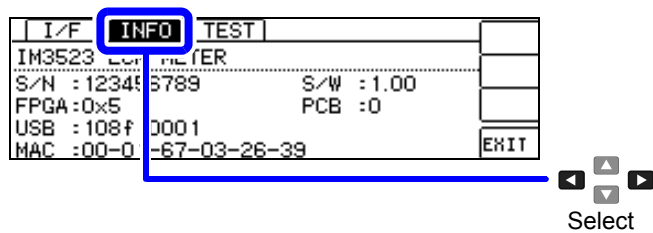

- 3**

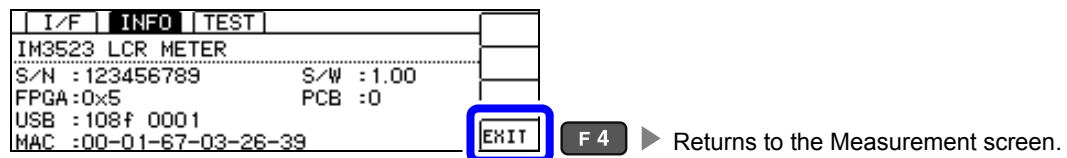

## 8.3 Self Checks (Self Diagnosis)

### Key Test

The key test allows you to verify whether the instrument's keys are functioning properly.

- 1 Open the System screen.

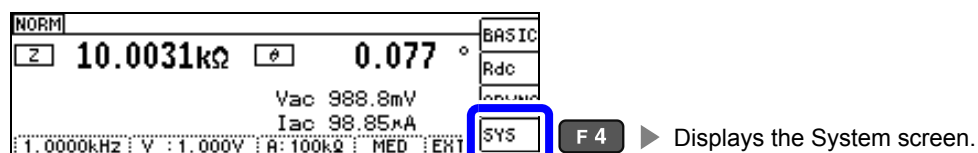

- 2 Select the [TEST] tab.

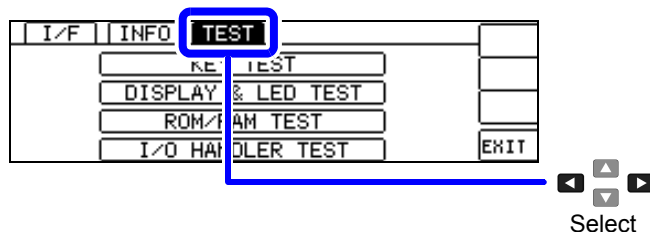

- 3 Select [KEY TEST].

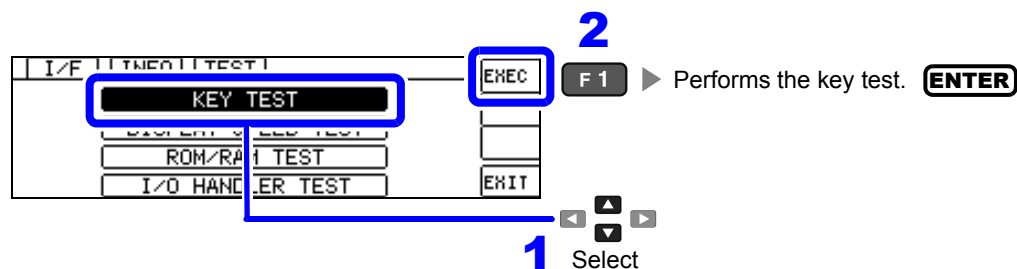

- 4 Press the rubber keys to perform the key test. Verify that the key on the screen corresponding to the key you pressed is shown in reverse video.

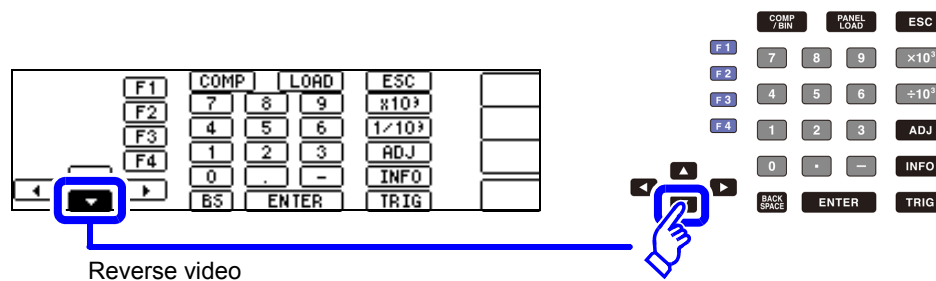

- 5

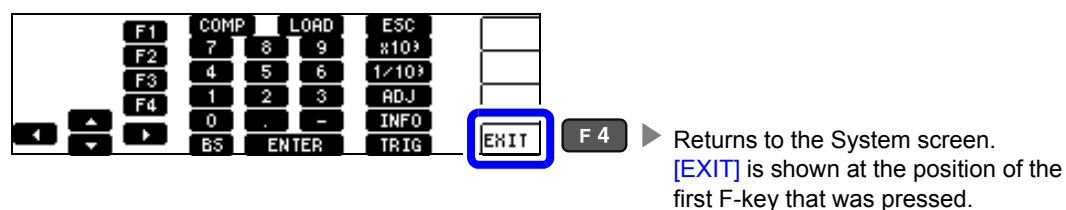

8.3 Self Checks (Self Diagnosis)

Screen Display Test

Check the display state of the screen and lighting state of the LEDs.

1 Open the System screen.

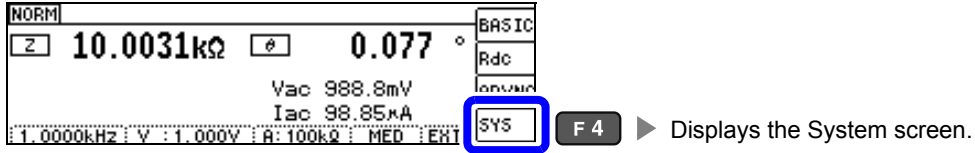

2 Select the [TEST] tab.

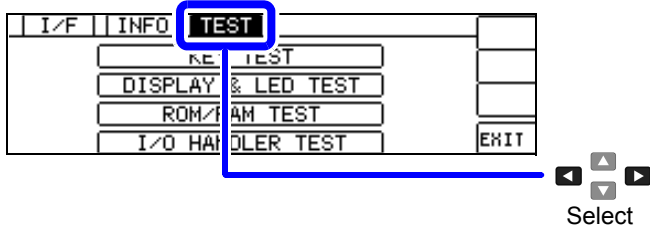

3 Select [DISPLAY&LED TEST].

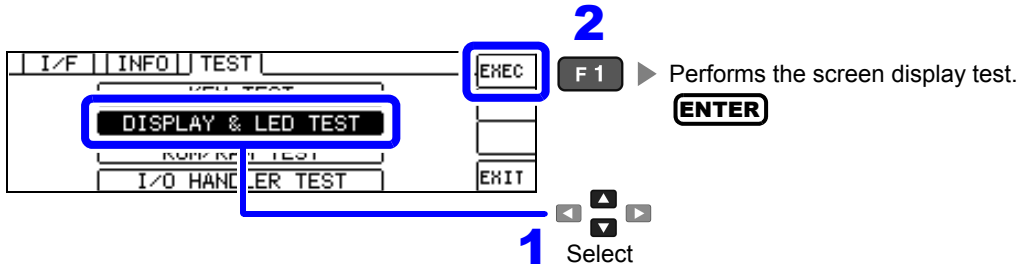

Each time you press **ENTER**, the screen and the LEDs on the front of the instrument will cycle on and off in the following order:

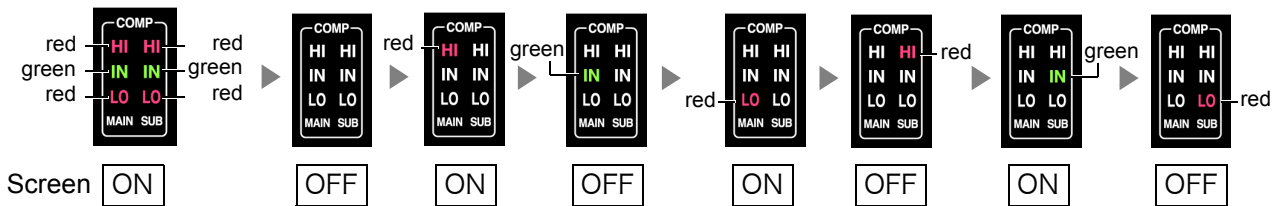

If the entire screen is not the same color or an LED fails to light up, the instrument needs to be repaired. Contact your dealer or Hioki representative.

4

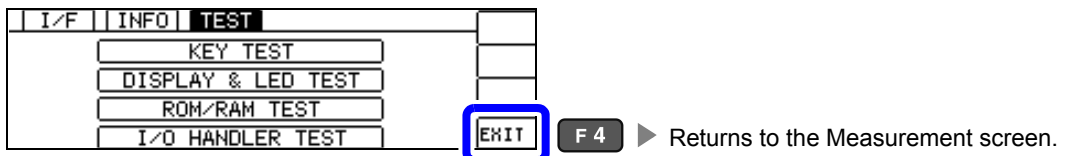

## ROM/RAM Test

Check the internal memory (ROM and RAM) of the instrument.

- 1 Open the System screen.

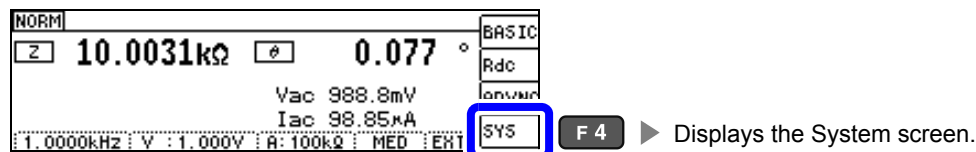

- 2 Select the [TEST] tab.

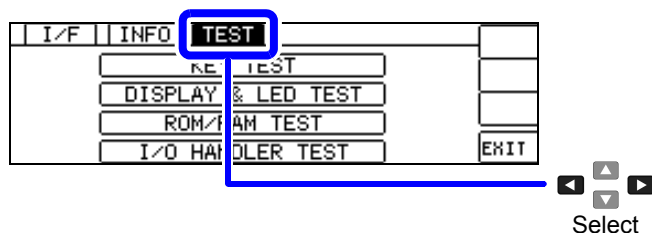

- 3 Select [ROM/RAM TEST].
  - Selecting EXEC will cause the test to start automatically. (Approx. 40 seconds)
  - No operation is possible during the ROM/RAM test.

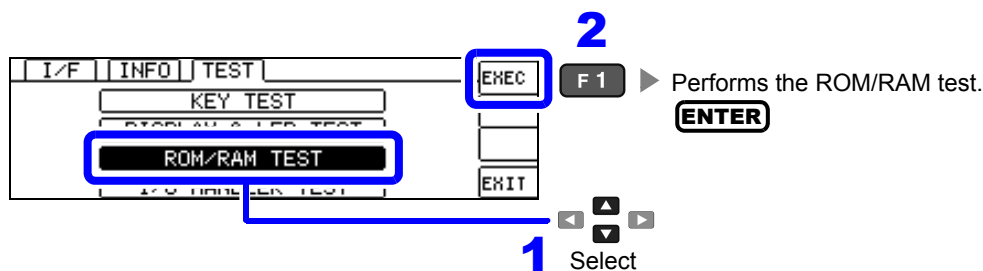

**CAUTION** Never turn off the power during a test.

- 4 Check the ROM/RAM test judgment results.  
If any of the judgment results are [NG], the instrument needs to be repaired. Contact your dealer or Hioki representative.

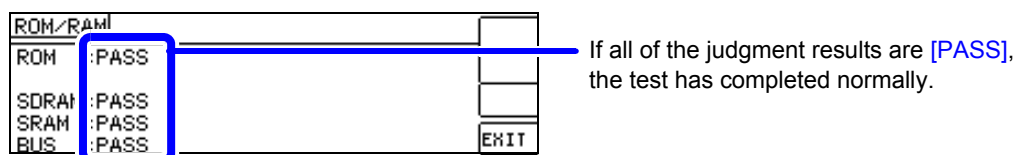

- 5

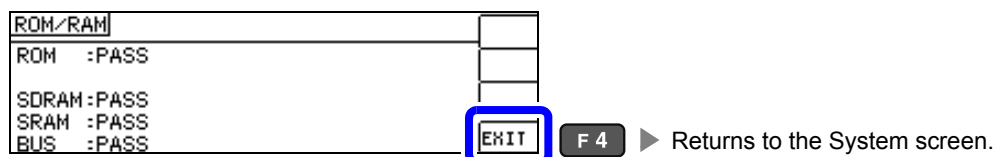

## 8.3 Self Checks (Self Diagnosis)

### I/O Test

Check whether an output signal is output normally from the EXT I/O, and whether an input signal is read normally.

- 1 Open the System screen.

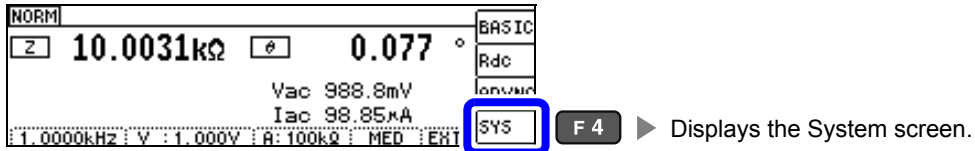

- 2 Select the [TEST] tab.

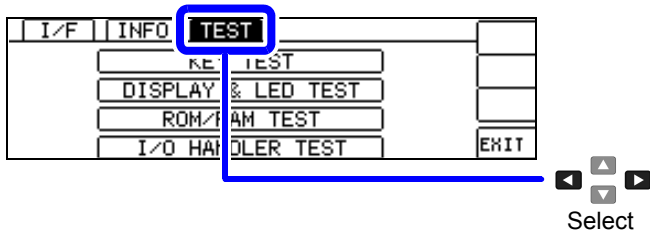

- 3 Select [I/O HANDLER TEST].

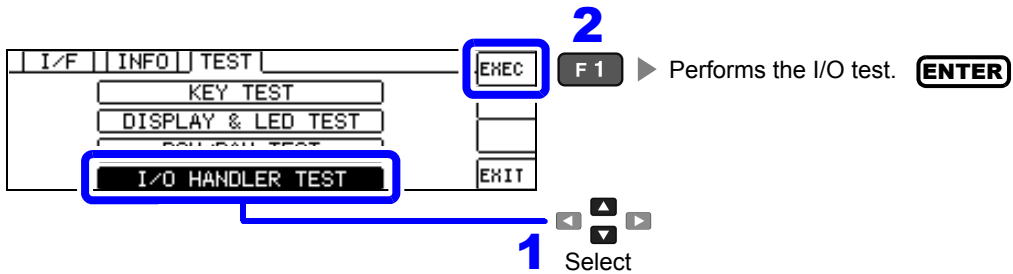

- 4 Perform the output signal test and input signal test.

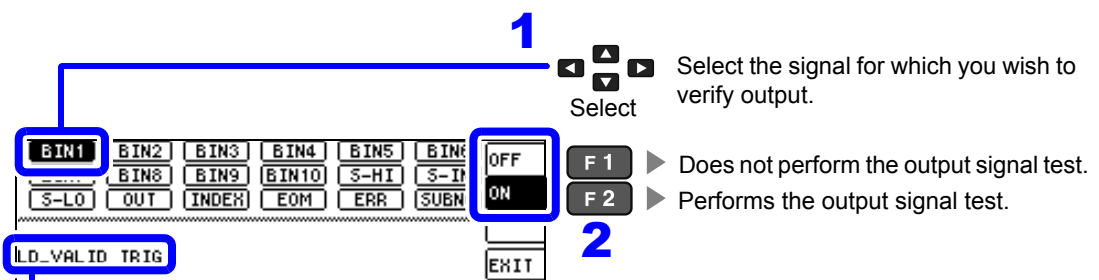

The names of signal lines that are being input (low) are shown in the input signal test window.

- 5

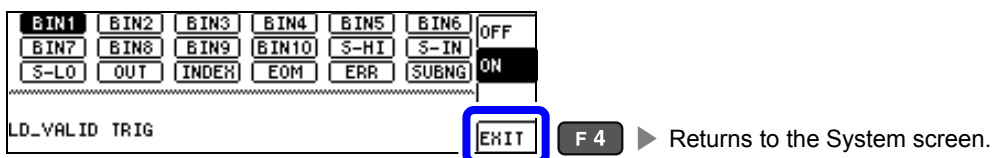

# External Control Chapter 9

The EXT I/O connector on the back of the instrument can be used to output measurement complete, judgment result, and other signals and to control the instrument by inputting measurement trigger, panel load, and other signals.

All signals are photocoupler-isolated. (The common pin [ISO\_COM pin] is used for both input and output.)

Confirm input and output ratings, understand the safety precautions for connecting a control system, and use accordingly.

**CAUTION** When connecting the instrument to your LAN with a LAN cable laid outdoors, take appropriate countermeasures that include installing a surge protector for LANs. Such signal wiring is susceptible to induced lighting, which can cause damage to the instrument.

Connect the instrument's EXT I/O connector to the signal output or input device.

Make instrument settings

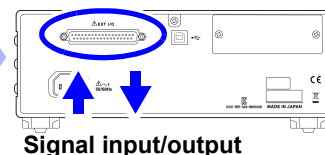

## 9.1 External Input/Output Connector and Signals



**WARNING** To avoid electric shock or damage to the equipment, always observe the following precautions when connecting to the EXT I/O terminals.

- Always turn off the power to the instrument and to any devices to be connected before making connections.
- During operation, a wire becoming dislocated and contacting another conductive object can be serious hazard. Make sure that connections are secure and use screws to secure the external connectors.
- Ensure that devices and systems to be connected to the EXT I/O terminals are properly isolated.

**CAUTION** To avoid damage to the instrument, observe the following cautions:

- Do not apply voltage or current to the EXT I/O terminals that exceeds their ratings.
- When driving relays, be sure to install diodes to absorb counter-electromotive force.
- Be careful not to short-circuit ISO\_5V to ISO\_COM.

See "Connector Type and Signal pin assignments" (p.178)

## 9.1 External Input/Output Connector and Signals

### Connector Type and Signal pin assignments

Rear

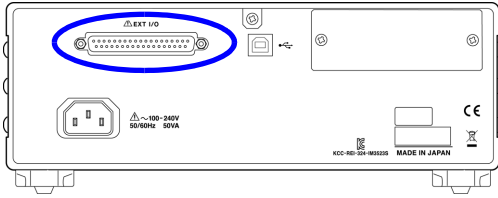

**Connector: (Instrument Side)**

- 37-pin D-sub female with #4-40 screws

**Mating Connectors:**

- DC-37P-ULR (solder type)
  - DCSP-JB37PR (pressure weld type)
- Japan Aviation Electronics Industry Ltd.

#### LCR Mode

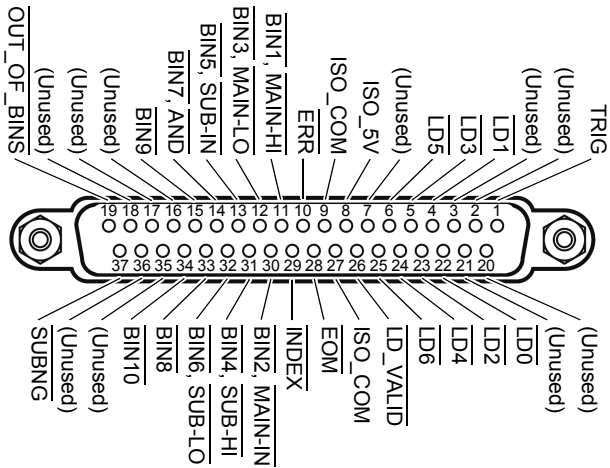

#### Continuous Measurement Mode

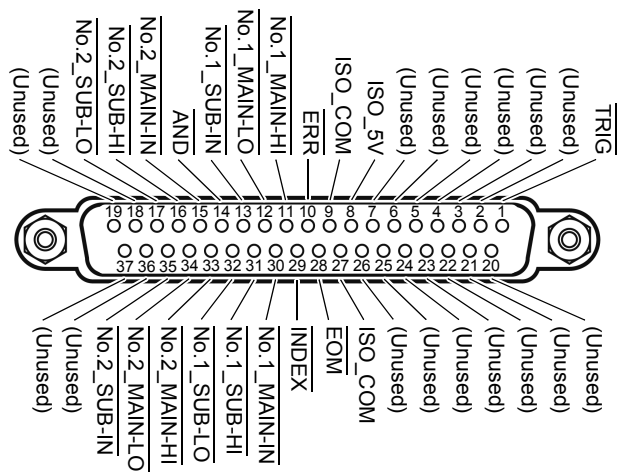

EXT I/O Connector (Instrument Side)

**NOTE** The connector shell is conductively connected to the metal instrument chassis and the protective earth pin of the power plug. Be aware that it is not isolated from ground.



## 9.1 External Input/Output Connector and Signals

### LCR Mode

Pin	I/O	Signal name			Function	Logic	
		Common	COMP	BIN			
1	IN	$\overline{\text{TRIG}}$			External trigger(p.184)	Positive/negative	Edge
2	–	(Unused)			–	–	–
3	–	(Unused)			–	–	–
4	IN	$\overline{\text{LD1}}$			Select panel number(p.184)	Neg	Level
5	IN	$\overline{\text{LD3}}$			Select panel number(p.184)	Neg	Level
6	IN	$\overline{\text{LD5}}$			Select panel number(p.184)	Neg	Level
7	–	(Unused)			–	–	–
8	–	ISO_5V			Isolated 5 V power output	–	–
9	–	ISO_COM			Isolated common signal ground	–	–
10	OUT	$\overline{\text{ERR}}$			Outputs when a sampling error, contact error, HiZ reject error, constant voltage/constant current error, or voltage/current limit value exceeded error occurs.	Neg	Level
11	OUT		$\overline{\text{MAIN-HI}}$		HI comparator judgment results for main parameters.	Neg	Level
				$\overline{\text{BIN1}}$	Generates output when the BIN measurement result is BIN1.		
12	OUT		$\overline{\text{MAIN-LO}}$		LO comparator judgment results for main parameters.	Neg	Level
					$\overline{\text{BIN3}}$		
13	OUT		$\overline{\text{SUB-IN}}$		IN comparator judgment results for sub parameters.	Neg	Level
					$\overline{\text{BIN5}}$		
14	OUT		$\overline{\text{AND}}$		Outputs an AND operation of judgment results of main and sub parameters. Generates output when both judgment results are IN. Additionally, generates output when either of the main or sub parameters is IN and the other is undetermined.	Neg	Level
					$\overline{\text{BIN7}}$		
15	OUT			$\overline{\text{BIN9}}$	Generates output when the BIN measurement result is BIN9.	Neg	Level
16	–	(Unused)			–	–	–
17	–	(Unused)			–	–	–
18	–	(Unused)			–	–	–
19	OUT			$\overline{\text{OUT}}$	BIN judgment results OUT	Neg	Level
20	–	(Unused)			–	–	–
21	–	(Unused)			–	–	–
22	IN	$\overline{\text{LD0}}$			Select panel number (p.184)	Neg	Level
23	IN	$\overline{\text{LD2}}$			Select panel number (p.184)	Neg	Level
24	IN	$\overline{\text{LD4}}$			Select panel number (p.184)	Neg	Level
25	IN	$\overline{\text{LD6}}$			Select panel number (p.184)	Neg	Level
26	IN	$\overline{\text{LD\_VALID}}$			Execute panel load (p.184)	Neg	Level
27	–	ISO_COM			Isolated common signal ground	–	–
28	OUT	$\overline{\text{EOM}}$			Measurement complete signal: When this signal is output, the comparator judgment results have been finalized.	Neg	Edge
29	OUT	$\overline{\text{INDEX}}$			Signal indicating that A/D conversion for the measurement circuit has completed: When this signal changes from high (off) to low (on), the sample may be changed.	Neg	Edge

## 9.1 External Input/Output Connector and Signals

### LCR Mode

Pin	I/O	Signal name			Function	Logic	
		Common	COMP	BIN			
30	OUT	$\overline{\text{MAIN-IN}}$			Outputs BIN judgment results and IN comparator judgment results for main parameters.	Neg	Level
				$\overline{\text{BIN2}}$	Generates output when the BIN measurement result is BIN2.		
31	OUT	$\overline{\text{SUB-HI}}$			HI comparator judgment results for sub parameters.	Neg	Level
				$\overline{\text{BIN4}}$	Generates output when the BIN measurement result is BIN4.		
32	OUT	$\overline{\text{SUB-LO}}$			LO comparator judgment results for sub parameters.	Neg	Level
				$\overline{\text{BIN6}}$	Generates output when the BIN measurement result is BIN6.		
33	OUT			$\overline{\text{BIN8}}$	Generates output when the BIN measurement result is BIN8.	Neg	Level
34	OUT			$\overline{\text{BIN10}}$	Generates output when the BIN measurement result is BIN10.	Neg	Level
35	–	(Unused)			–	–	–
36	–	(Unused)			–	–	–
37	OUT			$\overline{\text{SUBNG}}$	Outputs a fail BIN judgment for sub parameters.	Neg	Level

## Continuous measurement mode

Pin	I/O	Signal name	Function	Logic	
				Positive/negative	Edge
1	IN	$\overline{\text{TRIG}}$	External trigger(p.184)	Positive/negative	Edge
2	–	(Unused)	–	–	–
3	–	(Unused)	–	–	–
4	–	(Unused)	–	–	–
5	–	(Unused)	–	–	–
6	–	(Unused)	–	–	–
7	–	(Unused)	–	–	–
8	–	ISO_5V	Isolated 5 V power output	–	–
9	–	ISO_COM	Isolated common signal ground	–	–
10	OUT	$\overline{\text{ERR}}$	Outputs when a sampling error, contact error, HiZ reject error, constant voltage/constant current error, or voltage/current limit value exceeded error occurs.	Neg	Level
11	OUT	$\overline{\text{No.1\_MAIN-HI}}$	Outputs HI comparator judgment results for the No. 1 main parameter.	Neg	Level
12	OUT	$\overline{\text{No.1\_MAIN-LO}}$	Outputs LO comparator judgment results for the No. 1 main parameter.	Neg	Level
13	OUT	$\overline{\text{No.1\_SUB-IN}}$	Outputs IN comparator judgment results for the No. 1 sub parameter.	Neg	Level
14	OUT	$\overline{\text{AND}}$	Outputs when all panel judgments are IN and the instrument is not OUT_OF_BINS.	Neg	Level
15	OUT	$\overline{\text{No.2\_MAIN-IN}}$	Outputs IN comparator judgment results for the No. 2 main parameter.	Neg	Level
16	OUT	$\overline{\text{No.2\_SUB-HI}}$	Outputs HI comparator judgment results for the No. 2 sub parameter.	Neg	Level
17	OUT	$\overline{\text{No.2\_SUB-LO}}$	Outputs LO comparator judgment results for the No. 2 sub parameter.	Neg	Level
18	–	(Unused)	–	–	–
19	–	(Unused)	–	–	–
20	–	(Unused)	–	–	–
21	–	(Unused)	–	–	–
22	–	(Unused)	–	–	–
23	–	(Unused)	–	–	–
24	–	(Unused)	–	–	–
25	–	(Unused)	–	–	–
26	–	(Unused)	–	–	–
27	–	ISO_COM	Isolated common signal ground	–	–
28	OUT	$\overline{\text{EOM}}$	Measurement complete signal: When this signal is output, the comparator judgment results have been finalized.	Neg	Edge
29	OUT	$\overline{\text{INDEX}}$	Signal indicating that A/D conversion for the measurement circuit has completed: When this signal changes from high (off) to low (on), the sample may be changed.	Neg	Edge
30	OUT	$\overline{\text{No.1\_MAIN-IN}}$	Outputs IN comparator judgment results for the No. 1 main parameter.	Neg	Level
31	OUT	$\overline{\text{No.1\_SUB-HI}}$	Outputs HI comparator judgment results for the No. 1 sub parameter.	Neg	Level
32	OUT	$\overline{\text{No.1\_SUB-LO}}$	Outputs LO comparator judgment results for the No. 1 sub parameter.	Neg	Level
33	OUT	$\overline{\text{No.2\_MAIN-HI}}$	Outputs HI comparator judgment results for the No. 2 main parameter.	Neg	Level
34	OUT	$\overline{\text{No.2\_MAIN-LO}}$	Outputs LO comparator judgment results for the No. 2 main parameter.	Neg	Level
35	OUT	$\overline{\text{No.2\_SUB-IN}}$	Outputs IN comparator judgment results for the No. 2 sub parameter.	Neg	Level
36	–	(Unused)	–	–	–
37	–	(Unused)	–	–	–

## 9.1 External Input/Output Connector and Signals

### Signal Descriptions

You can select rising or falling for the valid edge of a trigger.

**See** "4.5.4 Enabling Trigger Input for during Measurement and Setting the Valid Edge of Trigger Input" (p.101)

### Input

$\overline{\text{TRIG}}$	<ul style="list-style-type: none"> <li>When the trigger is set to external trigger [EXT], one measurement is performed at the TRIG signal's falling edge (on) or rising edge (off). The edge direction can be set on the Settings screen. (Default value: Falling edge [on]) <b>See</b> "Enabling Trigger Input for during Measurement" (p.191)</li> <li>When the trigger source is set to the internal trigger [INT], trigger measurement is not performed.</li> <li>You can set whether to enable or disable TRIG signal input during measurement (while outputting the EOM signal [high]). <b>See</b> "4.5.4 Enabling Trigger Input for during Measurement and Setting the Valid Edge of Trigger Input" (p.101)</li> </ul>																																																																																
$\overline{\text{LD0 to LD6}}$	<p>Selects the number of the panel to load. If a trigger signal is input in external trigger mode, the selected panel is loaded and used for measurement.</p> <p>0 : (HIGH: 5 V to 24 V), 1 : (LOW: 0 V to 0.9 V)</p> <table border="1"> <thead> <tr> <th>PIN No.</th> <th><math>\overline{\text{LD6}}</math></th> <th><math>\overline{\text{LD5}}</math></th> <th><math>\overline{\text{LD4}}</math></th> <th><math>\overline{\text{LD3}}</math></th> <th><math>\overline{\text{LD2}}</math></th> <th><math>\overline{\text{LD1}}</math></th> <th><math>\overline{\text{LD0}}</math></th> </tr> </thead> <tbody> <tr> <td>Panel 1</td> <td>0</td> <td>0</td> <td>0</td> <td>0</td> <td>0</td> <td>0</td> <td>1</td> </tr> <tr> <td>Panel 2</td> <td>0</td> <td>0</td> <td>0</td> <td>0</td> <td>0</td> <td>1</td> <td>0</td> </tr> <tr> <td>Panel 4</td> <td>0</td> <td>0</td> <td>0</td> <td>0</td> <td>1</td> <td>0</td> <td>0</td> </tr> <tr> <td>Panel 8</td> <td>0</td> <td>0</td> <td>0</td> <td>1</td> <td>0</td> <td>0</td> <td>0</td> </tr> <tr> <td>Panel 16</td> <td>0</td> <td>0</td> <td>1</td> <td>0</td> <td>0</td> <td>0</td> <td>0</td> </tr> <tr> <td>Panel 32</td> <td>0</td> <td>1</td> <td>0</td> <td>0</td> <td>0</td> <td>0</td> <td>0</td> </tr> <tr> <td>Panel 64</td> <td>1</td> <td>0</td> <td>0</td> <td>0</td> <td>0</td> <td>0</td> <td>0</td> </tr> <tr> <td>Panel 127</td> <td>1</td> <td>1</td> <td>1</td> <td>1</td> <td>1</td> <td>1</td> <td>1</td> </tr> <tr> <td>Panel 128</td> <td>0</td> <td>0</td> <td>0</td> <td>0</td> <td>0</td> <td>0</td> <td>0</td> </tr> </tbody> </table>	PIN No.	$\overline{\text{LD6}}$	$\overline{\text{LD5}}$	$\overline{\text{LD4}}$	$\overline{\text{LD3}}$	$\overline{\text{LD2}}$	$\overline{\text{LD1}}$	$\overline{\text{LD0}}$	Panel 1	0	0	0	0	0	0	1	Panel 2	0	0	0	0	0	1	0	Panel 4	0	0	0	0	1	0	0	Panel 8	0	0	0	1	0	0	0	Panel 16	0	0	1	0	0	0	0	Panel 32	0	1	0	0	0	0	0	Panel 64	1	0	0	0	0	0	0	Panel 127	1	1	1	1	1	1	1	Panel 128	0	0	0	0	0	0	0
PIN No.	$\overline{\text{LD6}}$	$\overline{\text{LD5}}$	$\overline{\text{LD4}}$	$\overline{\text{LD3}}$	$\overline{\text{LD2}}$	$\overline{\text{LD1}}$	$\overline{\text{LD0}}$																																																																										
Panel 1	0	0	0	0	0	0	1																																																																										
Panel 2	0	0	0	0	0	1	0																																																																										
Panel 4	0	0	0	0	1	0	0																																																																										
Panel 8	0	0	0	1	0	0	0																																																																										
Panel 16	0	0	1	0	0	0	0																																																																										
Panel 32	0	1	0	0	0	0	0																																																																										
Panel 64	1	0	0	0	0	0	0																																																																										
Panel 127	1	1	1	1	1	1	1																																																																										
Panel 128	0	0	0	0	0	0	0																																																																										
$\overline{\text{LD-VALID}}$	<p>Inputs a negative logic signal from an external device so that the selected panel number is recognized as valid. After TRIG input, maintain a Low level until <math>\overline{\text{INDEX}}</math> is outputted.</p>																																																																																

## 9.1 External Input/Output Connector and Signals

### Error output

Priority Order	Measurement Error	Error Display	ERR No. 10 Pin *4	Comparator Measurement		BIN Measurement	
				Logical Product AND No. 14 Pin	Each Parameter Judgment Result Pin Nos. 11, 12, 13, 30, 31, and 32	BIN1 to BIN10, Pin Nos. 11 to 15 and 30 to 34	OUT_OF_BINS Pin No. 19
High ↑	Sampling error	<b>SAMPLE ERR</b>	LOW	HI	HI	HI	LOW
	H and L side contact errors (after measurement)	<b>NC A HL</b>	LOW	HI	LCR: 11, 31*1	HI	LOW
	L side contact error (after measurement)	<b>NC A L</b>	LOW	HI	LCR: 11, 31*1	HI	LOW
	H side contact error (after measurement)	<b>NC A H</b>	LOW	HI	LCR: 11, 31*1	HI	LOW
	H and L side contact errors (before measurement)	<b>NC B HL</b>	LOW	HI	LCR: 11, 31*1	HI	LOW
	L side contact error (before measurement)	<b>NC B L</b>	LOW	HI	LCR: 11, 31*1	HI	LOW
	H side contact error (before measurement)	<b>NC B H</b>	LOW	HI	LCR: 11, 31*1	HI	LOW
	Underflow	<b>UNDERFLOW</b>	HI	HI	LCR: 12, 32*1, 2	HI	LOW
	Overflow	<b>OVERFLOW</b>	HI	HI	LCR: 11, 31*1, 3	HI	LOW
	Outside of HI Z reject limit range	<b>Hi Z</b>	LOW	Normal judgment	Normal judgment	Normal judgment	Normal judgment
	Outside display range*4	<b>DISP OUT</b>	HI	Normal judgment	Normal judgment	Normal judgment	Normal judgment
	Outside of guaranteed accuracy range	<b>REF VAL</b>	HI	Normal judgment	Normal judgment	Normal judgment	Normal judgment
	Normal	measurement value	HI	Normal judgment	Normal judgment	Normal judgment	Normal judgment
	Low	No measurement after power turned on		HI	HI	HI	HI

\*1 Indicates the pin numbers that will be the LOW level.

\*2 LCR 11 and 31 will be LOW when the parameters are Y, Cs, G, and B.

\*3 LCR 12 and 32 will be LOW when the parameters are Y, Cs, G, and B.

\*4 LOW will be output if even one error occurs.

## 9.2 Timing Chart

### 9.2.1 LCR Measurement

If you set the judgment condition for the comparator (the trigger setting is external trigger) and then in that state a trigger signal is input from the EXT I/O or **TRIG** is pressed, the judgment result is output from the signal line for comparator result output of the EXT I/O after measurement ends.

Furthermore, if the panel number is selected with the panel load signal when a trigger signal is input from the EXT I/O, the measurement condition of that panel number is loaded and then measurement is performed.

The following shows examples of the measurement timing.

(In the timing examples, the valid edge of the TRIG signal is set to falling (ON).)

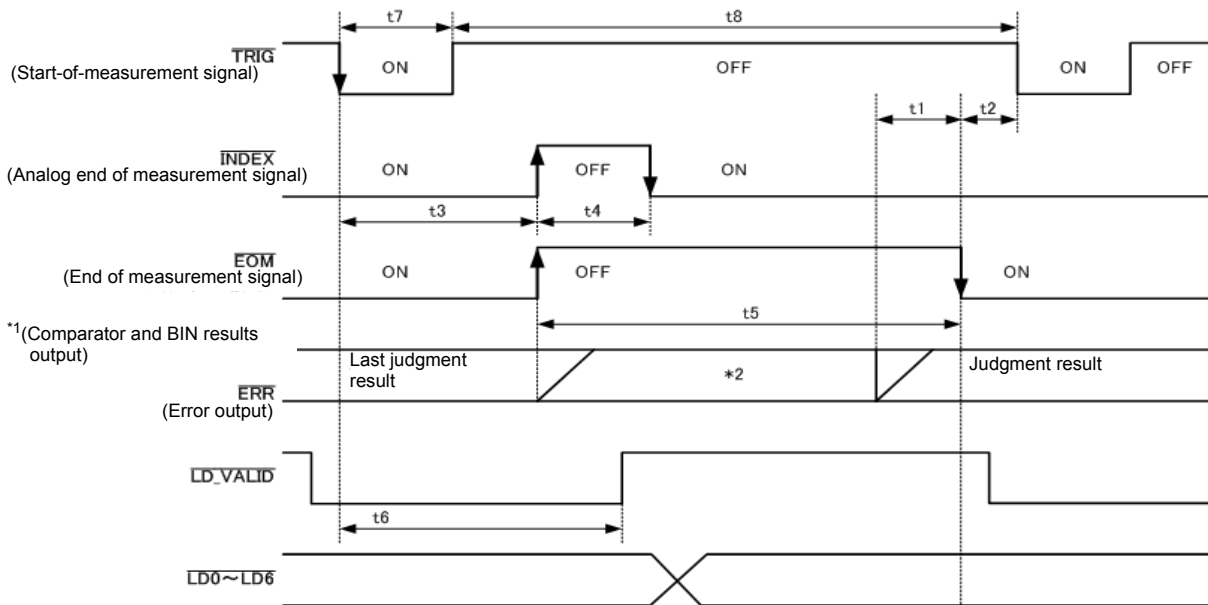

\*1 MAIN-HI, MAIN-IN, MAIN-LO, SUB-HI, SUB-IN, SUB-LO, AND BINx, OUT, SUBNG

\*2 Reset at EOM (HIGH) : HIGH  
Do not reset at EOM (HIGH) : Last judgment result remains

**NOTE** Whether the judgment results of comparator measurement are reset at  $\overline{\text{EOM}}$  (HIGH) or updated at the point in time when measurement ends can be selected on the instrument or by a communication command.

See "4.5.3 Setting the Delay Time from the Output of Comparator and BIN Judgment Results until Output of EOM (LOW) and Resetting Judgment Results" (p.100) Communications commands in the included LCR Application Disk documentation (:IO:RESult:RESet)

## Timing Chart Interval Descriptions

Interval	Description	Time(Approximate)
t1	From Comparator, BIN Judgement Result to $\overline{\text{EOM}}$ (LOW): Setting value for delay time *1	40 $\mu\text{s}$
t2	From $\overline{\text{EOM}}$ width (LOW) to $\overline{\text{TRIG}}$ (LOW): Minimum time from end of measurement to next trigger *2	400 $\mu\text{s}$
t3	From $\overline{\text{TRIG}}$ (LOW) to $\overline{\text{INDEX}}$ (HIGH) : Time from trigger to circuit response *3	600 $\mu\text{s}$
t4	$\overline{\text{INDEX}}$ width (HIGH) : Minimum chuck time, switching chuck with $\overline{\text{INDEX}}$ (LOW) is possible *4	1 ms
t5	$\overline{\text{EOM}}$ width (HIGH) : Measurement time *4	2 ms
t6	From $\overline{\text{TRIG}}$ width (LOW) to $\overline{\text{LD-VALID}}$ (HIGH): Time to recognize panel number	t3
t7	Trigger pulse width (LOW time)	100 $\mu\text{s}$ or more
t8	Trigger OFF (HI time)	100 $\mu\text{s}$ or more

\*1: There is an approximate error of 100  $\mu\text{s}$  in the delay time entered for Judgement Result  $\leftrightarrow \overline{\text{EOM}}$  for the setting value.

t1 is the reference value for when the setting value is 0.0000 s.

\*2: t2 is the reference value for when trigger input for during measurement is disabled.(p.101)

\*3: When the panel number is read by the panel load function, the response time is as shown in the table below.

Measurement mode	Load mode	Response time
LCR	LCR+ADJ	10 ms
	HARD	9 ms
	ADJ	4 ms

When the trigger synchronous output function and trigger delay is enabled, wait times are included.

\*4: Reference value for Measurement frequency: 1 kHz, Measurement speed: FAST, Measurement range: HOLD.(p.214)

- NOTE**
- Since the speed of the rise (LOW HIGH) of the comparator/BIN judgment result differs depending on the configuration of the circuit connected to the EXT I/O, there is the likelihood of an incorrect judgment if the level of the comparator/BIN judgment result acquired immediately after EOM output is used. To prevent this from happening, a delay time (t1) between the comparator/BIN judgment result and the EOM can be set. Furthermore, if the judgment result signal line of the EXT I/O is set to be reset simultaneously with the measurement start signal, and a forced transition to the HIGH level is performed at the same time as TRIG, the transition from LOW to HIGH does not occur when the judgment result is output after measurement ends. As a result, the delay time between the judgment result and the EOM can be set to the minimum level. However, be careful because the judgment result confirmation interval is until the next trigger is accepted.
  - During measurement, a trigger input from EXT /IO or communicating by interface may lead to a bigger dispersion of delay time between comparator or BIN judgement result output and EOM. As far as possible, try not to control from external sources when carrying out measurement.

**See** "4.5.3 Setting the Delay Time from the Output of Comparator and BIN Judgment Results until Output of EOM (LOW) and Resetting Judgment Results" (p.100)

**See** "4.5.4 Enabling Trigger Input for during Measurement and Setting the Valid Edge of Trigger Input" (p.101)

Communications commands in the included LCR Application Disk documentation  
 (: IO:OUTPut:DELay)  
 (: IO:RESult:RESet)

## 9.2 Timing Chart

**NOTE** The shorter the measurement time, the shorter the time that  $\overline{\text{INDEX}}$  and  $\overline{\text{EOM}}$  are high (off). When the high (off) time is too short due to characteristics of the input circuit, the instrument can be configured to maintain the low (on) state for a preset time once EOM changes to low (on) before reverting the signal to high (off) after the completion of measurement. When trigger input is received at EOM:LOW and INDEX:LOW, the signal transitions to high (off) when measurement starts.

### Setting the $\overline{\text{INDEX}}$ and $\overline{\text{EOM}}$ output method

See "4.5.5 Setting the EOM Output Method" (p.102)

Communications commands in the included LCR Application Disk documentation( : IO : EOM : MODE )

### Setting the pulse width for which low (on) $\overline{\text{EOM}}$ is held

See "4.5.5 Setting the EOM Output Method" (p.102)

Communications commands in the included LCR Application Disk documentation( : IO : EOM : PULSe )

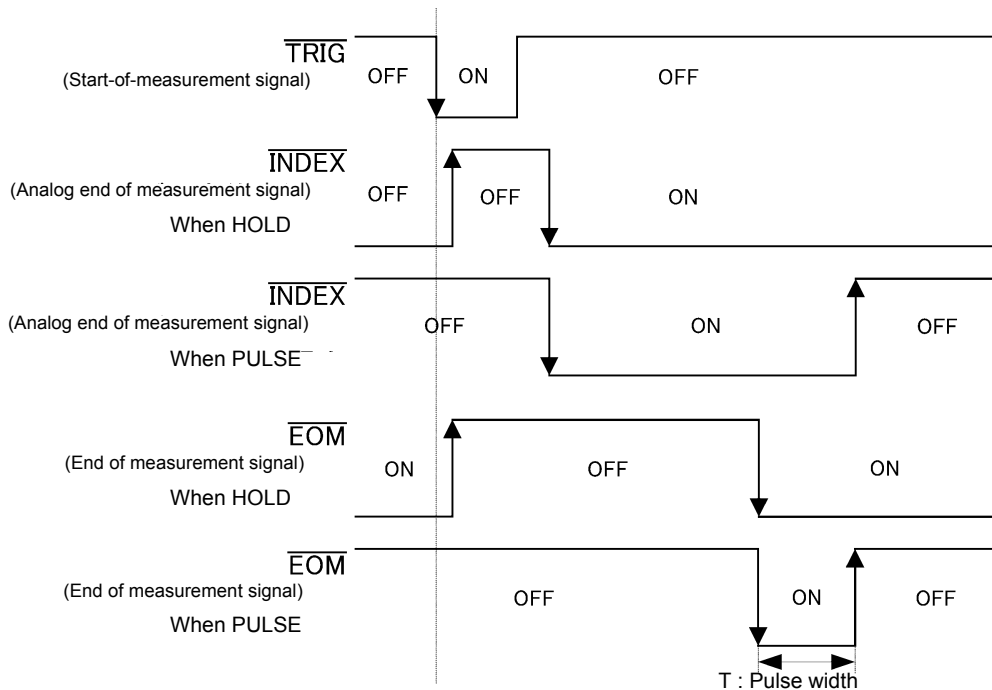



## 9.2.2 Continuous Measurement

With continuous measurement, if a trigger signal is input from the EXT I/O or **TRIG** is pressed, after measurement of all of the panel numbers set to be executed on the screen is finished, the main and sub parameter judgment results will be output from the EXT I/O comparator result output signal lines. The following shows examples of the measurement timing.

(In the timing examples, the valid edge of the TRIG signal is set to falling (ON).)

Example: Continuous measurement using panel numbers 1 and 3.

CONT >> BASIC		EXEC:2/2		OFF
No.	EXEC	PANEL NAME	MODE	PARA
001	ON	NEW_PANEL	ALL	Z- 0
002	OFF	NEW_PANEL	ALL	Z- 0
003	ON	NEW_PANEL	ALL	Z- 0
004	OFF	NEW_PANEL	ALL	Z- 0

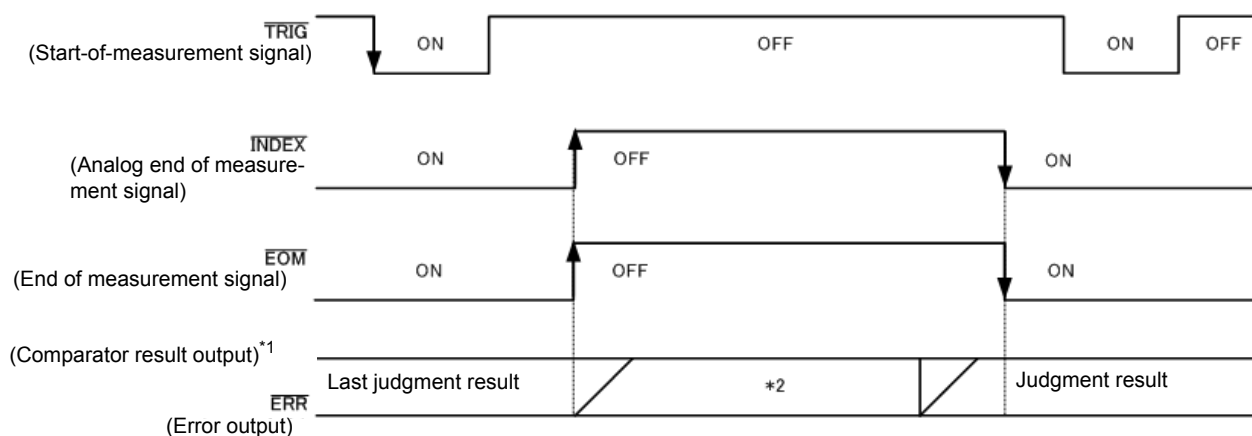

\*1 No.x\_MAIN-HI, No.x\_MAIN-IN, No.x\_MAIN-LO, No.x\_SUB-HI, No.x\_SUB-IN, No.x\_SUB-LO, AND

\*2 Reset at  $\overline{\text{EOM}}$  (HIGH) : HIGH

Do not reset at  $\overline{\text{EOM}}$  (HIGH) : Last judgment result remains

Signal line	Description
$\overline{\text{INDEX}}$ , $\overline{\text{EOM}}$	For both $\overline{\text{INDEX}}$ and $\overline{\text{EOM}}$ , a transition to HIGH is performed when the first panel measurement starts after the trigger signal is input, and a transition to LOW is performed after measurement of the last panel is finished and the judgment result has been output. (The HIGH level is maintained during continuous measurement.)
$\overline{\text{AND}}$	When the judgment results of all panels are IN, LOW is output.

**NOTE** • In the continuous measurement screen, comparator result output signals other than AND and panel load signals (LD-VALID, LD0 to LD6) cannot be used.

See "Chapter 5 Continuous Measurement Function" (p.119)

• Whether the judgment results of comparator measurement are reset at EOM (HIGH) or updated at the point in time when measurement ends can be selected on the instrument or by a communication command.

See "4.5.3 Setting the Delay Time from the Output of Comparator and BIN Judgment Results until Output of EOM (LOW) and Resetting Judgment Results" (p.100)  
Communications commands in the included LCR Application Disk documentation  
( :IO:RESult:RESet)

• For other timing chart times, refer to "9.2.1 LCR Measurement" (p.184).

# 9.3 Internal Circuitry

Input Circuit

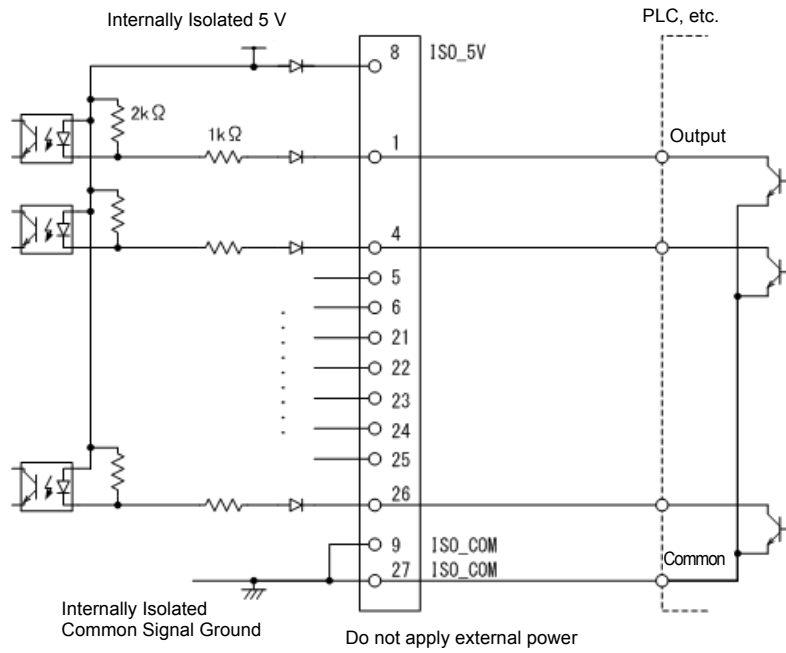

Output Circuit

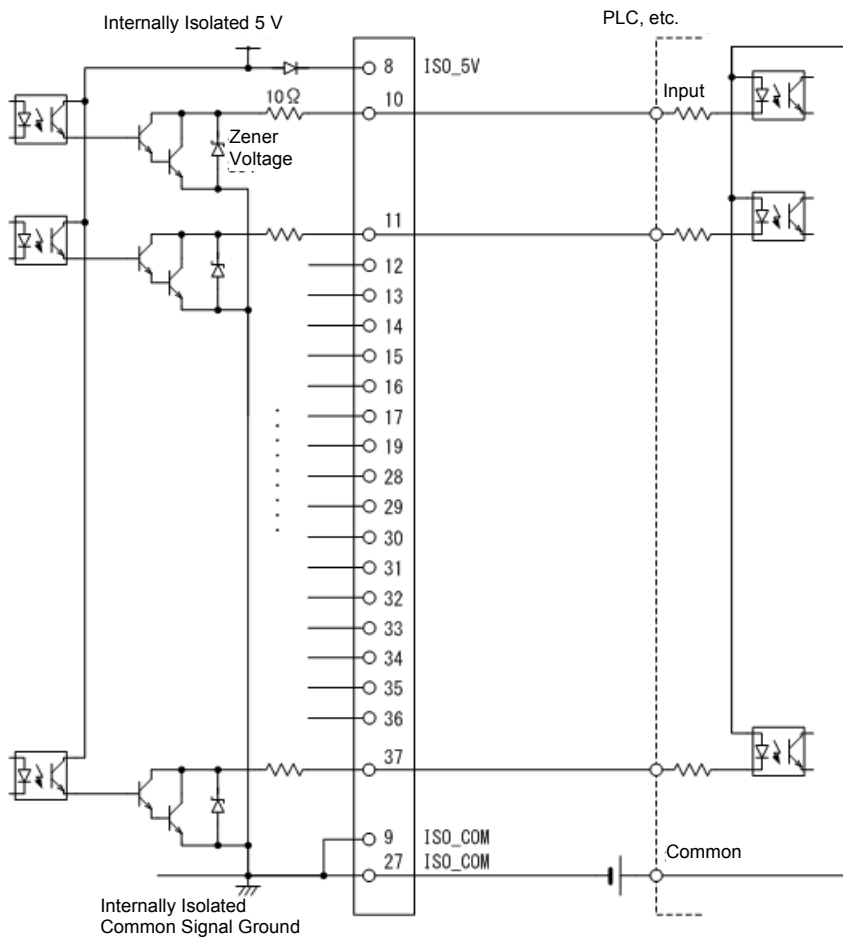

## Electrical Specifications

Input Signals	Input type	Optocoupler-isolated, non-voltage contact inputs (source input, active-low)
	Input asserted (ON) voltage	1 V or less
	Input de-asserted (OFF) voltage	Open or 5 to 30 V
	Input asserted (ON) current	3 mA/ch
	Maximum applied voltage	30 V
Output Signals	Output type	Optocoupler-isolated npn open-collector outputs (current sink, active-low)
	Maximum load voltage	30 V
	Maximum output current	50 mA/ch
	Residual voltage	1 V (10 mA), 1.5 V (50 mA)
Built-in isolated power supply	Power Output	4.5 V to 5.0 V
	Maximum output current	100 mA
	External power input	none

Connection Examples

Input Circuit Connection Examples

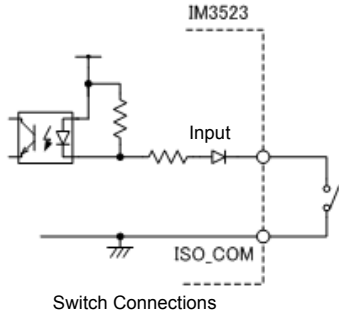

Switch Connections

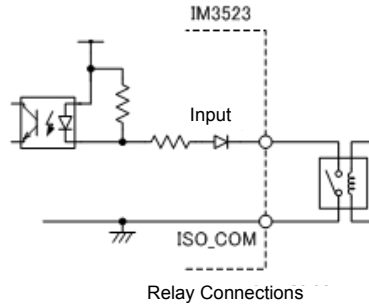

Relay Connections

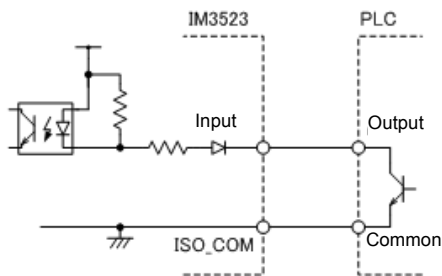

PLC Input (Sink Input) Connections

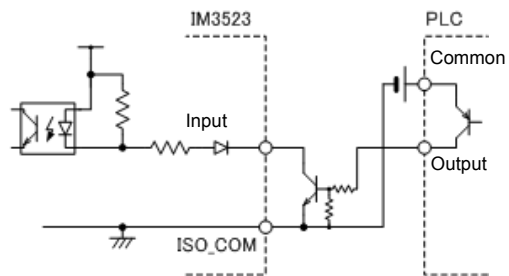

PLC Input (Source Input) Connections

Output Circuit Connection Examples

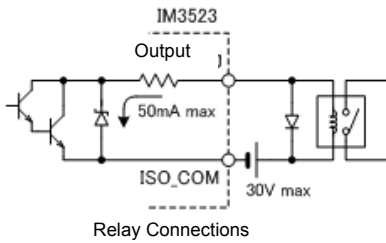

Relay Connections

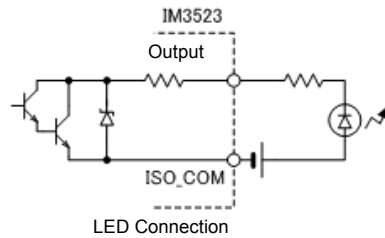

LED Connection

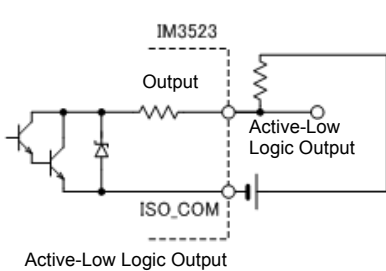

Active-Low Logic Output

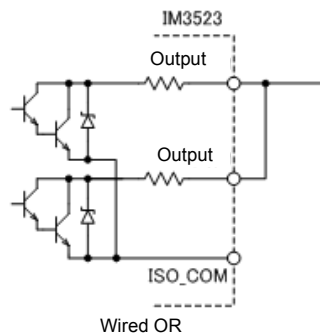

Wired OR

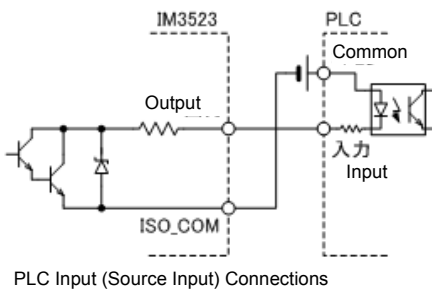

PLC Input (Source Input) Connections

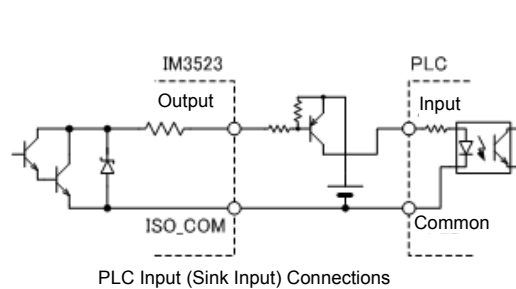

PLC Input (Sink Input) Connections

## 9.4 External I/O Settings

There are the following setting items for the output timing of the judgment result output signal and the logic of the trigger signal.

### Setting Delay Time from Output of Comparator and BIN Judgment Results until Output of EOM (LOW)

The delay time for the period from the output of the comparator and BIN judgment results until the output of EOM (LOW) from the EXT I/O can be set on the instrument or by a communication command.

**See** "4.5.3 Setting the Delay Time from the Output of Comparator and BIN Judgment Results until Output of EOM (LOW) and Resetting Judgment Results" (p.100)

Communications commands in the included LCR Application Disk documentation  
(**:IO:OUTPut:DELay**)

### Setting Reset of Judgment Results

Whether to reset the comparator and BIN judgment results simultaneously with the measurement start signal can be selected on the instrument or by a communication command.

**See** "4.5.3 Setting the Delay Time from the Output of Comparator and BIN Judgment Results until Output of EOM (LOW) and Resetting Judgment Results" (p.100)

Communications commands in the included LCR Application Disk documentation  
(**:IO:RESult:RESet**)

### Enabling Trigger Input for during Measurement

Whether to enable or disable trigger input from the EXT I/O during measurement (during EOM (HI) output) can be selected on the instrument or by a communication command.

**See** "4.5.4 Enabling Trigger Input for during Measurement and Setting the Valid Edge of Trigger Input" (p.101)

Communications commands in the included LCR Application Disk documentation  
(**:IO:TRIGger:ENABle**)

### Setting Valid Edge of Trigger Input

Either the rising edge or falling edge can be selected as the valid edge of trigger input from the EXT I/O.

**See** "4.5.4 Enabling Trigger Input for during Measurement and Setting the Valid Edge of Trigger Input" (p.101)

Communications commands in the included LCR Application Disk documentation  
(**:IO:TRIGger:EDGe**)

## 9.5 External Control Q&A

Common Questions	Answers
How do I connect external trigger input?	Connect the (active low) $\overline{\text{TRIG}}$ input pin to an ISO_COM pin using a switch or open-collector output.
Which pins are common ground for input and output signals?	The ISO_COM pins.
Are the common (signal ground) pins shared by both inputs and outputs?	Both common ground pins can be shared by inputs and outputs.
How do I confirm output signals?	Confirm voltage waveforms with a recorder or an oscilloscope. To do this, the output pins such as $\overline{\text{EOM}}$ and comparator decision outputs need to be pulled up (through several k $\Omega$ ).
How do I troubleshoot input (control) signal issues?	For example, if triggering does not operate properly, bypass the PLC and short the $\overline{\text{TRIG}}$ pin directly to an ISO_COM pin. Be careful to avoid power shorts.
Are the comparator decision signals retained during measurement (or can they be off)?	They are initially set to be confirmed at the end of measurement and turned OFF when measurement starts. However, it is possible to change the settings so that the judgment results from last time are also stored during measurement. <a href="#">See</a> "Setting Reset of Judgment Results" (p.191)
When are measurement error signals displayed?	An error is displayed in the following cases. <ul style="list-style-type: none"> <li>• When sampling error</li> <li>• When constant voltage/constant current error</li> <li>• When voltage/current limit value exceeded error</li> <li>• When contact check error in low Z high accuracy mode</li> <li>• When HIGH-Z reject error</li> </ul>
Is a connector or flat cable for connection provided?	A connector and cable are not supplied, so you need to provide them yourself.
Is direct connection to a PLC possible?	Direct connection is supported for relay or open-collector outputs and positive-ground optocoupler inputs. (Before connecting, confirm that voltage and current ratings will not be exceeded.)
Can external I/O be used at the same time as RS-232C or other communications?	After setting up communications, it is possible to control measurement with the $\overline{\text{TRIG}}$ signal while acquiring measurement data via a communications interface.
How should external power be connected?	The instrument's external I/O input and output signals all operate from an internal isolated power source, so power must not be supplied from the PLC side.

## 9.6 Measurement Using a Computer

You can control the instrument with communication commands from a computer via the USB, GP-IB, RS-232C, and LAN interfaces.

To enable communication, the communication conditions need to be set on the instrument.

For details on the communication condition settings, refer to "8.1 Setting the Interface" (p.171) .

For the details on the communication control procedure, refer to the supplied Communication Instruction Manual (LCR Application Disk).





# Printing

# Chapter 10

Connecting the printer  
to the instrument

Make instrument  
settings(p. 197)

Make printer  
settings(p. 197)

## Printing(p. 198)

- Measurement values and comparator decisions
- Statistical calculation results

## 10.1 Connecting the Printer

Before Connecting the Printer



**WARNING** Because electric shock and instrument damage hazards are present, always follow the steps below when connecting the printer.

- Always turn off the instrument and the printer before connecting.
- A serious hazard can occur if a wire becomes dislocated and contacts another conductor during operation. Make certain connections are secure.

### NOTE

A printer can only be connected when the Z3001 RS-232C Interface is installed.

Recommended printer

The printer connected to the instrument must implement the following specifications and settings. Check the printer's specifications and settings before connecting it to the instrument.

**See** "10.2 Instrument and Printer Settings" (p. 197)

- Interface ..... RS-232C
- Characters per line ..... At least 45
- Communication speed ..... Initial value : 9,600bps
- Data bits ..... Fixed : 8bit
- Parity ..... Fixed : none
- Stop bits ..... Fixed : 1bit
- Flow control ..... Initial value : none

### NOTE

The communication speed and flow control can be changed with instrument settings. However, the IM3523 and printer must be configured with the same settings.

### Connecting the Printer to the Instrument

#### Procedure

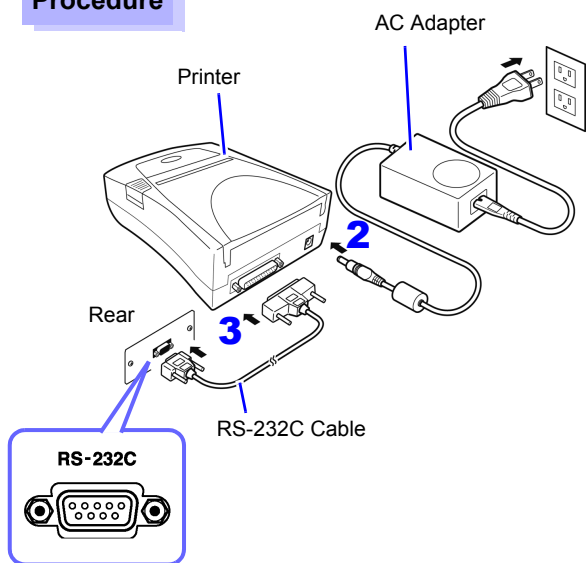

- 1** Confirm that the instrument and Printer are turned off.
- 2** Connect an AC Adapter to a Printer, and insert the power plug into an outlet.
- 3** Connect a RS-232C Cable to the RS-232C connectors on the instrument and printer.
- 4** Turn the instrument and printer on.

#### Connector pin assignments

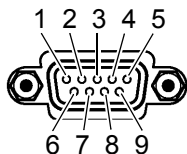

Z3001 RS-232C Interface (9-pin) Connector

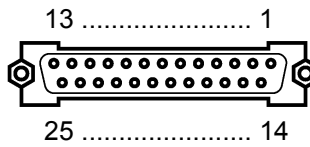

Printer (25-pin) Connector

Function	Signal Name	Pin
Receive Data	RxD	2
Transmit Data	TxD	3
Signal or Common Ground	GND	5
Request to Send	RTS	7
Clear to Send	CTS	8

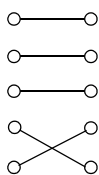

Pin	Signal Name	Function
2	TxD	Transmit Data
3	RxD	Receive Data
7	GND	Signal or Common Ground
4	RTS	Request to Send
5	CTS	Clear to Send

- NOTE** • To use hardware flow control, you will need an RS-232C cable with RTS and CTS wires that are connected each other (7-pin at instrument to 5-pin at printer or 8-pin at instrument to 4-pin printer,) which is compatible with Interlink. Hardware flow control cannot be used with cables whose RTS and CTS wires are shorted together.
- Please be careful about the connector pin assignment to select a printer other than the recommended one.

## 10.2 Instrument and Printer Settings

### Make Instrument Settings

- 1 Open the System screen.

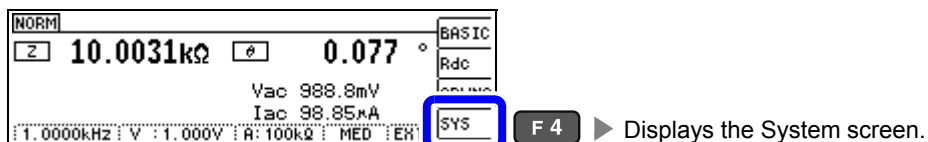

- 2 Set the interface type to [PRINT].

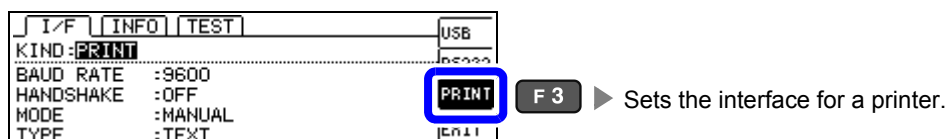

- 3 Set the communications speed (baud rate) for the printer.

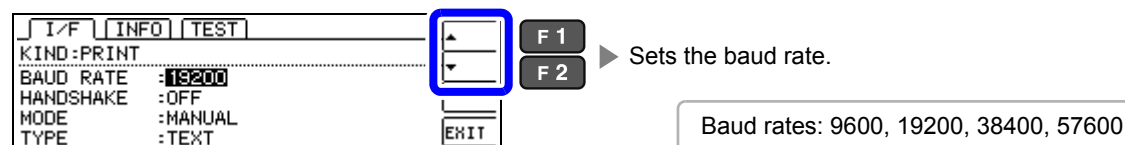

- 4 Set the type of flow control.

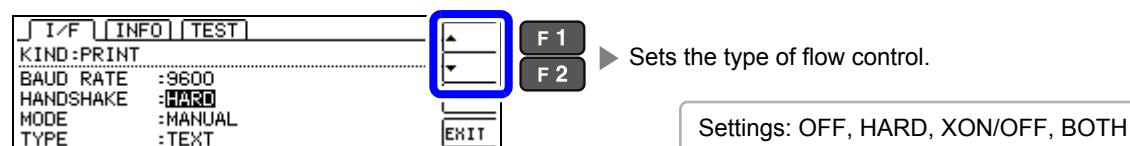

- 5 Set the print method.

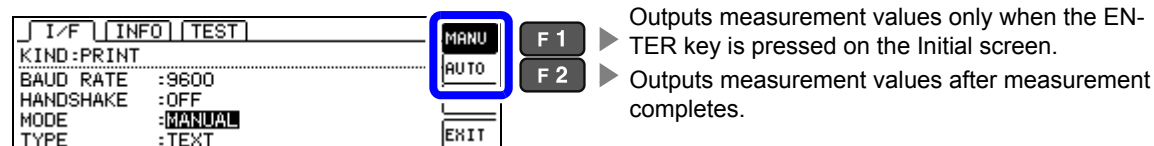

- 6 Set the print type.

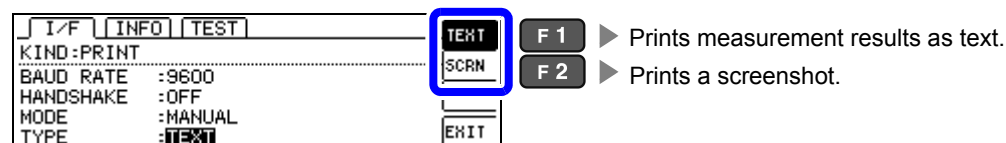

7

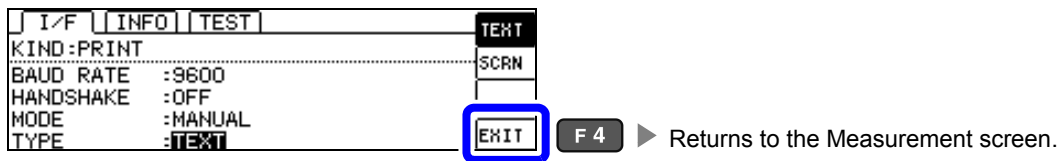

The printer's communication speed (baud rate) and flow control settings are the same as the RS-232C settings. You may be able to increase the print speed by changing the baud rate. It is also necessary to change the printer's communication speed setting. When the communication speed is increased, the printer may be unable to keep up, preventing data from being printed properly. If this occurs, use hardware or software flow control. For more information, see the instruction manual that came with the printer.

## 10.3 Printing

### Before Printing

Verify that the instrument and printer settings (p. 197) are correct.

### When the Printing Method is Set to [AUTO]

Prints automatically after measurement completes.

When the external trigger is enabled, pressing **TRIG** initiates printing.

Since the AUTO setting causes measurement data to be printed automatically, it is recommended to print using the external trigger.

### When the Printing Method is Set to [MANUAL]

Prints the state when **ENTER** is pressed in the initial screen.

Example Printouts

The print content varies depending on the printer settings of the instrument.  
 See "10.2 Instrument and Printer Settings" (p. 197)

When LCR Mode

When the [TYPE] setting is [TEXT].

Normal measurement

```
Z 10.0089kohm
PH 0.028 deg
```

Comparator measurement

```
Z 10.0088kohm IN
PH 0.028 deg HI
```

BIN measurement

```
Z 10.0086kohm
PH 0.028 deg
BIN3
```

When the [TYPE] setting is [SCREEN].

NORM		BASIC	
Z	10.0028kΩ	φ	0.079 °
Vac 988.9mV		Rdc	
Iac 98.86mA		ADVNC	
1.0000kHz		SYS	
V: 1.000V		MED	
R: 100kΩ		EXT	

When Continuous Measurement Mode

When the [TYPE] setting is [TEXT] or [SCREEN].

```
001 Z 10.0088kohm PH 0.028 deg -- --
002 Z 10.0088kohm PH 0.028 deg IN HI
```

- NOTE**
- In continuous measurement mode, text will be printed even when the [TYPE] setting is set to [SCREEN].
  - Because printer settings cannot be configured in continuous measurement mode, place the instrument in LCR mode if you need to change the printer settings.



# Specifications Chapter 11

All AC voltage and AC current values are rms values

## 11.1 General Specifications

### 1. Basic Specifications

Measurement mode (1) LCR mode: Measurement with single condition  
(2) Continuous Measurement Mode: Up to 2 consecutive measurements using saved conditions

Measurement items Z (Impedance), Y (Admittance),  $\theta$  (Phase angle), Rs (Equivalent series resistance (ESR)), Rp (Equivalent parallel resistance), X (Reactance), G (Conductance), B (Susceptance), Ls (Equivalent series inductance), Lp (Equivalent parallel inductance), Cs (Equivalent series capacitance), Cp (Equivalent parallel capacitance), Q (Q factor), D (Loss coefficient  $\tan\delta$ ), Rdc (DC resistance)

Display range

Parameter	Display range (6 digits)
Z	0.00 m to 9.99999 G $\Omega$
Y	0.000 n to 9.99999 GS
$\theta$	$\pm 0.000^\circ$ to 999.999 $^\circ$
Rs, Rp, X, Rdc	$\pm 0.00$ m to 9.99999 G $\Omega$
G, B	$\pm 0.000$ n to 9.99999 GS
Cs, Cp	$\pm 0.0000$ p to 9.99999 GF
Ls, Lp	$\pm 0.00000$ $\mu$ to 9.99999 GH
D	$\pm 0.00000$ to 9.99999
Q	$\pm 0.00$ to 99999.9
$\Delta\%$	$\pm 0.000$ to 999.999%

Measurement frequency (1) Frequency range  
40 Hz to 200 kHz  
(2) Setting resolution  
40.000 Hz to 99.999 Hz ..... 1 mHz steps  
100.00 Hz to 999.99 Hz ..... 10 mHz steps  
1.0000 kHz to 9.9999 kHz ..... 100 mHz steps  
10.000 kHz to 99.999 kHz ..... 1 Hz steps  
100.00 kHz to 200.00 kHz ..... 10 Hz steps  
(3) Frequency accuracy  
 $\pm 0.01\%$  of setting or less

Output impedance Normal mode:  $100 \Omega \pm 10 \Omega$   
(Hc terminal, when 1 kHz)

## 11.1 General Specifications

### 1. Basic Specifications

Measurement signal level	(1) Open circuit terminal voltage (V) mode and constant voltage (CV) mode <ul style="list-style-type: none"> <li>• Level range            Normal mode:5 mV to 5 V, maximum 50 mA</li> <li>• Setting resolution    1 mV steps</li> <li>• Setting accuracy      <math>\pm 10\%</math> of setting <math>\pm 10</math> mV</li> </ul>
	(2) Constant current (CC) mode <ul style="list-style-type: none"> <li>• Level range            Normal mode:10 <math>\mu</math>A to 50 mA, maximum 5 V</li> <li>• Setting resolution    10 <math>\mu</math>A steps</li> <li>• Setting accuracy      <math>\pm 10\%</math> of setting <math>\pm 10</math> <math>\mu</math>A</li> </ul>

Measurement range    The measurement range is determined according to impedance Z  
 The values of the other measurement items can be calculated  
 Ranges:100 m $\Omega$ , 1  $\Omega$ , 10  $\Omega$ , 100  $\Omega$ , 1 k $\Omega$ , 10 k $\Omega$ , 100 k $\Omega$ , 1 M $\Omega$ , 10 M $\Omega$ , 100 M $\Omega$   
 (10 ranges)

Measurement range	Guaranteed Accuracy Range	AUTO Ranging Range
100 M $\Omega$	8 M $\Omega$ to 200 M $\Omega$	8 M $\Omega$ to
10 M $\Omega$	800 k $\Omega$ to 100 M $\Omega$	800 k $\Omega$ to 10 M $\Omega$
1 M $\Omega$	80 k $\Omega$ to 10 M $\Omega$	80 k $\Omega$ to 1 M $\Omega$
100 k $\Omega$	8 k $\Omega$ to 1 M $\Omega$	8 k $\Omega$ to 100 k $\Omega$
10 k $\Omega$	800 $\Omega$ to 100 k $\Omega$	800 $\Omega$ to 10 k $\Omega$
1 k $\Omega$	80 $\Omega$ to 10 k $\Omega$	80 $\Omega$ to 1 k $\Omega$
100 $\Omega$	8 $\Omega$ to 100 $\Omega$	8 $\Omega$ to 100 $\Omega$
10 $\Omega$	800 m $\Omega$ to 10 $\Omega$	800 m $\Omega$ to 10 $\Omega$
1 $\Omega$	80 m $\Omega$ to 1 $\Omega$	80 m $\Omega$ to 1 $\Omega$
100 m $\Omega$	10 m $\Omega$ to 100 m $\Omega$	0 $\Omega$ to 100 m $\Omega$

- The guaranteed accuracy range differs depending on the measurement conditions (p.209)
- Out of guaranteed accuracy is displayed when out of the ranging range  
 OVERFLOW or UNDERFLOW is displayed when out of the A/D input range

Period of guaranteed accuracy    1 year

Warm-up time                          At least 60 minutes

Measurement time                    Approx. 2.0 ms (1 kHz, FAST, no screen display)

Measurement speed                  FAST, MED, SLOW, SLOW2

Terminal structure                    4-terminal structure

Backup battery life                    Approx. 10 years

Product warranty period              3 years

### 2. Function

Monitor functions	(1) Monitor voltage <ul style="list-style-type: none"> <li>• Monitor range        0.000 V to 5.000 V</li> <li>• Monitor accuracy    <math>\pm 10\%</math> rdg. <math>\pm 10</math> mV</li> </ul>
	(2) Monitor current <ul style="list-style-type: none"> <li>• Monitor range        0.000 mA to 50.00 mA</li> <li>• Monitor accuracy    <math>\pm 10\%</math> rdg. <math>\pm 10</math> <math>\mu</math>A</li> </ul>



## 2. Function

Limit function	(1) Current limit (when V or CV) <ul style="list-style-type: none"> <li>Limit range 0.01 mA to 50.00 mA</li> <li>Limit accuracy <math>\pm 10\%</math> rdg. <math>\pm 10 \mu\text{A}</math></li> </ul> (2) Voltage limit (when CC set) <ul style="list-style-type: none"> <li>Limit range 0.005 V to 5.000 V</li> <li>Limit accuracy <math>\pm 10\%</math> rdg. <math>\pm 10 \text{ mV}</math></li> </ul>
Average	1 to 256 (1 step)
Trigger function	An internal trigger or external trigger can be set
Trigger delay	0 to 9.9999 s (0.0001 s resolution)
BIN measurement	10 main parameters, 1 sub parameter, OUT, SUBNG, Absolute value setting, $\Delta\%$ setting, % setting
Comparator	LCR mode: MAIN item.....Hi/IN/Lo SUB item ..... Hi/IN/Lo Absolute value setting, $\Delta\%$ setting, % setting
Compensation	<ul style="list-style-type: none"> <li>Open and short circuit compensation</li> <li>Load circuit compensation</li> <li>Cable length compensation: 0 m, 1 m</li> </ul> Guaranteed accuracy up to 4 m when cable length compensation of 1 m set
Correlation compensation	Enter the compensation coefficients a and b of the following expression [Measurement value after compensation] = a $\times$ [measurement value] + b
Residual charge protection function (Provides protection against a discharge voltage from a charged capacitor)	$V = \sqrt{\frac{I_0}{C}}$ <p>C: Capacitance [F] of test sample However, V = maximum 400 V</p>
Screen contrast	Adjustment range: 0% to 100%
Continuous measurement	Perform continuous measurement with saved conditions from the screen Up to 2 judgment results can be output simultaneously from EXT I/O.
Display digits setting function	The number of display digits for measurement values can be set to 3, 4, 5, and 6 However, the setting differs depending on the parameter. (The initial value is 6 digits)
Display setting function	The LCD can be set to ON/ OFF
Key-lock function	Can be enabled and disabled by front panel key operation Can be enabled and disabled by password input
Trigger synchronous output function	Applies a measurement signal during analog measurement only.
Panel save and load function	All measurement conditions : 60 different measurement conditions can be saved Correction values only : 128 different measurement conditions can be saved Any measurement condition can be load by key operation or a control signal via the EXT I/O
Memory function	32,000 measurement result items can be saved to the instrument (Reading via USB, RS-232C, GP-IB and LAN is possible. GP-IB, RS-232C, and LAN interfaces are optional.)

## 2. Function

Contact check	(1) 4-terminal contact check Performs a contact (disconnection) check between $H_{CUR}$ and $H_{POT}$ and between $L_{CUR}$ and $L_{POT}$ Threshold values can be changed: 1 to 5 (5 high sensitivity, low contact resistance value)  (2) HIGH-Z reject function (detection of OPEN state during 2-terminal measurement) When the measurement value is higher than the judgment reference, a contact error is output Judgment reference: Can be set from 0% to 30,000% of range full scale (with 1% resolution). Error output: An error is output from the EXT I/O
Print function	The measurement values can be printed. (Requires Z3001 RS-232C Interface and RS-232C-compatible printer.)
Buzzer sound	The buzzer for the comparator judgment result (IN or NG) can be set to ON/ OFF The buzzer sound for key input can be set to ON/ OFF Any of four buzzer tones can be selected

---

### 3. Interface

Display	Monochrome LCD
Handler interface	Equipped as standard
USB interface	Equipped as standard Full-Speed/Hi-Speed support
Option Unit	Z3000 GP-IB Interface Unit (Option) Z3001 RS-232C Interface Unit (Option) Z3002 LAN Interface Unit (Option) *

\*: A LAN cable has to be 30 m long or less.

Commands are compatible with those for Model 3522-50 (basically, compatible with Model IM3570).

### 4. Environmental and Safety Specifications

Operating temperature and humidity	0 to 40°C (32 to 104°F) , 80%RH or less (non-condensating)
Storage temperature and humidity	-10 to 55°C (14 to 131°F) 80% RH or less (non-condensating)
Operating environment	Indoors, pollution degree2, altitude up to 2000 m (6562-ft.)
Rated supply voltage	100 V to 240 VAC
Rated supply frequency	50/60 Hz
Maximum rated power consumption	50 VA
Dimensions	Approx. 260 W × 88 H × 203 D mm (10.24" W × 3.46" H × 7.99" D) (excluding protrusions)
Mass	Approx. 2.4 kg (84.7 oz.)
Applicable Standards	
Safety	EN61010
EMC	EN61326 Class A
Dielectric strength	Between the power wire and ground wire: 1.62 kVAC for 1 minute

### 5. Accessories, Options

Accessories	Power Cord.....1 Instruction Manual (This document) .....1 LCR Application Disk.....1 (Communication Instruction Manual (PDF-format), explanation of communications commands, USB driver, sample application)
Options	Model 9261-10 Test Fixture Model 9262 Test Fixture Model 9263 SMD Test Fixture Model 9677 SMD Test Fixture Model 9699 SMD Test Fixture Model IM9100 SMD Test Fixture Model IM9110 SMD Test Fixture Model L2000 4-Terminal Probe Model 9140-10 4-Terminal Probe Model 9500-10 4-Terminal Probe Model L2001 Pincher Probe Model 9268-10 DC Bias Voltage Unit Model 9269-10 DC Bias Current Unit Z3000 GP-IB Interface Unit Z3001 RS-232C Interface Unit Z3002 LAN Interface Unit

# 11.2 Measurement Range and Accuracy

The measurement accuracy is calculated from a basic accuracy, which is based on the accuracy for impedance Z (%) and phase angle  $\theta$  ( $^{\circ}$ ), and the following coefficients.

**Measurement accuracy = Basic accuracy  $\times$  C  $\times$  D  $\times$  E  $\times$  F**  
 C: Level coefficient/ D: Measurement speed coefficient/ E: Cable length coefficient/  
 F: Temperature coefficient

**Basic accuracy**

Measurement conditions of basic accuracy coefficient table.

- Using the Model 9262 Test Fixture
- Measurement speed: SLOW2
- Cable length: 0 m
- Operation 60 minutes after the power is turned on.
- Open circuit compensation and short circuit compensation both being performed.
- Temperature and humidity: 23 $\pm$ 5 $^{\circ}$ C, 80 %RH or less

When the measurement conditions differ from the above, multiply the level coefficient (C), measurement speed coefficient (D), cable length coefficient (E), and temperature coefficient (F) by the basic accuracy.

The basic accuracy is calculated by determining coefficient A and B from the basic accuracy coefficient table in accordance with the measurement frequency and measurement range, and then using the following expression.

The basic accuracy becomes the accuracy [%] of Z and accuracy [ $^{\circ}$ ] of  $\theta$ .

**Basic accuracy formula**

1 k $\Omega$  range or more

$$\text{Basic accuracy} = \pm \left( A + B \times \left| \frac{10 \times Z_x[\Omega]}{\text{Range}[\Omega]} - 1 \right| \right)$$

100  $\Omega$  range or less

$$\text{Basic accuracy} = \pm \left( A + B \times \left| \frac{\text{Range}[\Omega]}{Z_x[\Omega]} - 1 \right| \right)$$

Z<sub>x</sub>: Impedance (effective value or value obtained by the following expression) of the test sample

$$\begin{aligned} Z_x[\Omega] &= \omega L [H] && (\text{When } \theta = 90^{\circ}) \\ &= 1 / \omega C [F] && (\text{When } \theta = -90^{\circ}) \\ &= R[\Omega] && (\text{When } \theta = 0^{\circ}) \end{aligned}$$

See "Example calculation" (p. 210)

## Accuracy table

Upper portion: Impedance Z (Unit: %) Lower portion: Phase angle  $\theta$  (Unit: °)

Range	DC	40.000Hz to 99.999 Hz	100.00 Hz to 999.99 Hz	1.0000 kHz to 10.000 kHz	10.001 kHz to 100.00 kHz	100.01 kHz to 200.00 kHz
100 M $\Omega$	A= 1 B= 1	A= 6 B= 5	A= 3 B= 2	A= 3 B= 2	- -	- -
		A= 5 B= 3	A= 2 B= 2	A= 2 B= 2	- -	- -
10 M $\Omega$	A= 0.5 B= 0.3	A= 0.8 B= 1	A= 0.5 B= 0.3	A= 0.5 B= 0.3	A= 3 B= 2	- -
		A= 0.8 B= 0.5	A= 0.4 B= 0.2	A= 0.4 B= 0.2	A= 2 B= 2	- -
1 M $\Omega$	A= 0.2 B= 0.1	A= 0.4 B= 0.08	A= 0.3 B= 0.05	A= 0.3 B= 0.05	A= 0.7 B= 0.08	A= 1 B= 0.5
		A= 0.3 B= 0.08	A= 0.2 B= 0.02	A= 0.2 B= 0.02	A= 1.5 B= 0.08	A= 3 B= 0.5
100 k $\Omega$	A= 0.1 B= 0.01	A= 0.3 B= 0.03	A= 0.2 B= 0.03	A= 0.15 B= 0.02	A= 0.25 B= 0.04	A= 0.4 B= 0.3
		A= 0.3 B= 0.02	A= 0.1 B= 0.02	A= 0.1 B= 0.015	A= 0.4 B= 0.02	A= 1.2 B= 0.3
10 k $\Omega$	A= 0.1 B= 0.01	A= 0.3 B= 0.025	A= 0.2 B= 0.025	A= 0.05 B= 0.02	A= 0.2 B= 0.025	A= 0.3 B= 0.03
		A= 0.3 B= 0.02	A= 0.1 B= 0.02	A= 0.03 B= 0.02	A= 0.4 B= 0.02	A= 0.6 B= 0.05
1 k $\Omega$	A= 0.1 B= 0.01	A= 0.3 B= 0.02	A= 0.2 B= 0.02	A= 0.15 B= 0.02	A= 0.2 B= 0.02	A= 0.3 B= 0.02
		A= 0.2 B= 0.02	A= 0.1 B= 0.02	A= 0.08 B= 0.02	A= 0.4 B= 0.02	A= 0.6 B= 0.02
100 $\Omega$	A= 0.1 B= 0.02	A= 0.4 B= 0.02	A= 0.3 B= 0.02	A= 0.15 B= 0.02	A= 0.2 B= 0.02	A= 0.3 B= 0.03
		A= 0.2 B= 0.01	A= 0.15 B= 0.01	A= 0.1 B= 0.01	A= 0.4 B= 0.02	A= 0.6 B= 0.02
10 $\Omega$	A= 0.2 B= 0.15	A= 0.5 B= 0.2	A= 0.4 B= 0.05	A= 0.3 B= 0.05	A= 0.3 B= 0.05	A= 0.4 B= 0.2
		A= 0.3 B= 0.1	A= 0.3 B= 0.03	A= 0.15 B= 0.03	A= 0.75 B= 0.05	A= 1.5 B= 0.1
1 $\Omega$	A= 0.3 B= 0.3	A= 2 B= 1	A= 0.6 B= 0.3	A= 0.4 B= 0.3	A= 0.4 B= 0.3	A= 1 B= 1
		A= 1 B= 0.6	A= 0.5 B= 0.2	A= 0.25 B= 0.2	A= 1 B= 0.2	A= 2 B= 0.5
100 m $\Omega$	A= 3 B= 3	A= 10 B= 10	A= 3 B= 3	A= 3 B= 2	A= 2 B= 2	A= 4 B= 3
		A= 6 B= 6	A= 2 B= 2	A= 2 B= 1.5	A= 2 B= 1.5	A= 3 B= 4

## C Level coefficient

The coefficient corresponding to the setting for measurement level is obtained from the measurement level coefficient table and then multiplied by the basic accuracy.

AC measurement

	0.005 V to 0.999 V	1 V	1.001 V to 5 V
Level coefficient	$1 + \frac{0.2}{V}$	1	$1 + \frac{2}{V}$

V: Measurement value (equivalent to when V mode) [V]

DC resistance measurement

	2 V
Level coefficient	1

## D Measurement speed coefficient

The coefficient corresponding to the setting for measurement speed is obtained from the measurement speed coefficient table and then multiplied by the basic accuracy.

		FAST	MED	SLOW	SLOW2
Speed coefficient	AC measurement	8	4	2	1
	DC resistance measurement	4	3	2	1

When the waveform averaging function is enabled, the coefficient corresponding to the set measurement frequency is obtained from the measurement speed coefficient table at the time of waveform averaging and then multiplied by the basic accuracy.

11.2 Measurement Range and Accuracy

Measurement speed coefficient table when the waveform averaging function is enabled

No	Frequency band	Settable range	Measurement speed coefficient			
			4	3	2	1
1	DC (Line frequency 50 Hz)	1 to 24	1 to 2	3 to 4	5 to 19	20 to 24
	DC (Line frequency 60 Hz)	1 to 24	1 to 2	3 to 5	6 to 23	24

No	Frequency band	Settable range	Out of guaranteed accuracy	Measurement speed coefficient			
				8	4	2	1
5	40.000 Hz to 99.999 Hz	1 to 40	-	1	2 to 4	5 to 39	40
6	100.00 Hz to 300.00 Hz	1 to 50	-	1	2 to 4	5 to 49	50
7	300.01 Hz to 500.00 Hz	1 to 200	-	1	2 to 9	10 to 199	200
8	500.01 Hz to 1.0000 Hz	1 to 300	-	1 to 4	5 to 19	20 to 299	300
9	1.0001 kHz to 2.0000 kHz	1 to 600	1	2 to 7	8 to 39	40 to 599	600
10	2.0001 kHz to 3.0000 kHz	1 to 1200	1 to 3	4 to 11	12 to 59	60 to 1199	1200
11	3.0001 kHz to 5.0000 kHz	1 to 2000	1 to 5	6 to 19	20 to 99	100 to 1999	2000
12	5.0001 kHz to 10.000 kHz	1 to 3000	1 to 9	10 to 39	40 to 199	200 to 2999	3000
13	10.001 kHz to 20.000 kHz	1 to 1200	1 to 3	4 to 15	16 to 79	80 to 1199	1200
14	20.001 kHz to 30.000 kHz	1 to 480	1	2 to 5	6 to 23	24 to 479	480
15	30.001 kHz to 50.000 kHz	1 to 800	1	2 to 9	10 to 39	40 to 799	800
16	50.001 kHz to 100.00 kHz	1 to 1200	1 to 3	4 to 15	16 to 79	80 to 1199	1200
17	100.01 kHz to 200.00 kHz	1 to 2400	1 to 7	8 to 31	32 to 159	160 to 2399	2400

**NOTE** When the measurement frequency falls outside the guaranteed accuracy, instrument operation is considered to be outside the guaranteed accuracy.

E Cable length coefficient

The coefficient corresponding to the setting for measurement cable length is obtained from the measurement cable length table and then multiplied by the basic accuracy.

		0 m	1 m	2 m	4 m
Cable length coefficient	10 kΩ range or less	1	1.2	$1.5 + \frac{fm}{100}$	$2 + \frac{fm}{50}$
	100 kΩ range and over	1	1.2	$1.5 + \frac{fm}{20}$	$2 + \frac{fm}{10}$

fm: Measurement frequency [kHz]

	Cable length	10 kΩ range or less	100 kΩ range and over
Guaranteed Accuracy Range (frequency)	0 m	Up to 200 kHz	
	1 m	Up to 200 kHz	
	2 m	Up to 200 kHz	Up to 100 kHz
	4 m	Up to 200 kHz	Up to 10 kHz

## F Temperature coefficient

The coefficient corresponding to the operating temperature is obtained from the operating temperature coefficient table and then added to the basic accuracy.

	$0^{\circ}\text{C} \leq t < 18^{\circ}\text{C}, 28^{\circ}\text{C} < t \leq 40^{\circ}\text{C}$	$18^{\circ}\text{C} \leq t \leq 28^{\circ}\text{C}$
Temperature coefficient	$1+0.1 \times  t - 23 $	1

When the operating temperature (t) is  $23^{\circ}\text{C} \pm 5^{\circ}\text{C}$ , the coefficient is 1.

## Guaranteed Accuracy Range

The guaranteed accuracy range is as follows.

The guaranteed accuracy range varies with the sample's impedance.

range	Sample impedance	40.000 Hz to 99.999 Hz	100.00 Hz to 999.99 Hz	1.0000 kHz to 10.000 kHz	10.001 kHz to 100.00 kHz	100.01 kHz to 200.00 kHz
100 M $\Omega$	8 M $\Omega$ to 200 M $\Omega$	0.101 V to 5 V			0.501 V to 5 V	
10 M $\Omega$	800 k $\Omega$ to 10 M $\Omega$					
1 M $\Omega$	80 k $\Omega$ to 1 M $\Omega$	0.05 V to 5 V		0.101 V to 5 V		
100 k $\Omega$	8 k $\Omega$ to 100 k $\Omega$	0.005 V to 5V			0.05 V to 5 V	0.101 V to 5 V
10 k $\Omega$	800 $\Omega$ to 10 k $\Omega$					
1 k $\Omega$	80 $\Omega$ to 1 k $\Omega$					
100 $\Omega$	8 $\Omega$ to 100 $\Omega$					
10 $\Omega$	800 m $\Omega$ to 10 $\Omega$	0.05 V to 5 V				
1 $\Omega$	80 m $\Omega$ to 1 $\Omega$	0.101 V to 5 V				
100 m $\Omega$	10 m $\Omega$ to 100 m $\Omega$	0.501 V to 5 V				

range	Sample impedance	40.000 Hz to 99.999 Hz	100.00 Hz to 999.99 Hz	1.0000 kHz to 10.000 kHz	10.001 kHz to 100.00 kHz	100.01 kHz to 200.00 kHz
10 M $\Omega$	10 M $\Omega$ to 100 M $\Omega$	0.101 V to 5 V			0.501 V to 5 V	
1 M $\Omega$	1 M $\Omega$ to 10 M $\Omega$					
100 k $\Omega$	100 k $\Omega$ to 1 M $\Omega$	0.05 V to 5 V		0.101 V to 5 V		
10 k $\Omega$	10 k $\Omega$ to 100 k $\Omega$	0.005 V to 5V			0.05 V to 5 V	0.101 V to 5 V
1 k $\Omega$	1 k $\Omega$ to 10 k $\Omega$					

The voltage values in the above table refer to the voltage setting for V mode.

### **NOTE**

The above measurement specification was determined using a 1.5D-2V coaxial cable with an established cable length for the instrument.

Using a cable other than a 1.5D-2V, or a cable that not an established length for the instrument in question increases the chance of measurement inaccuracy. A large capacitance between the H terminal and grounding capacitance (GND) or the L terminal and GND may result in measurement inaccuracy. Please set the GND to 10 pF or less.

## 11.2 Measurement Range and Accuracy

### Example calculation

- Impedance ( $Z=50\ \Omega$ ) basic accuracy  
(For example) Measurement conditions: measurement frequency=10 kHz, measurement speed=SLOW2

Accuracy table(p.207)

range			1.0000 kHz to 10.000 kHz		
1 k $\Omega$					
100 $\Omega$			A= 0.15 B= 0.02		Z
			A= 0.1 B= 0.01		$\theta$
10 $\Omega$					

- Because  $Z$  is  $50\ \Omega$ , the  $100\ \Omega$  measurement range will be used.
- Obtain the  $Z$  coefficients  $A$  and  $B$  from the accuracy table (p.207) and then calculate the basic accuracy of  $Z$ .  
In the 10 kHz/100  $\Omega$  range, the accuracy table (p.207) yields the values  $A = 0.15$  and  $B = 0.02$ .

Using the basic accuracy formula (p.206) for 100  $\Omega$  or less ranges,

$$Z \text{ accuracy} = \pm \left( 0.15 + 0.02 \times \left| \frac{100}{50} - 1 \right| \right) = \pm 0.17\%$$

- Similarly, calculate the basic accuracy of  $\theta$ .  
The accuracy table (p.207) yields the values  $A = 0.1$  and  $B = 0.01$

Using the basic accuracy formula (p.206) for 100  $\Omega$  and lower ranges,

$$\theta \text{ accuracy} = \pm \left( 0.1 + 0.01 \times \left| \frac{100}{50} - 1 \right| \right) = \pm 0.11^\circ$$

- Capacitance ( $C_s=160\ \text{nF}$ ) basic accuracy  
(For example) Measurement conditions: measurement frequency=1 kHz, measurement speed=SLOW2



Accuracy table(p.207)

range			1.0000 kHz to 10.000 kHz		
100 kΩ					
10 kΩ			A= 0.05 B= 0.02	Z	
			A= 0.03 B= 0.02	θ	
1 kΩ					

1. Measure the sample's Z and θ values using auto-ranging.
2. Assume that the measured Z and θ values are as follows:

$$Z = 1.0144 \text{ k}\Omega, \theta = -78.69^\circ$$

Because Z is 1.0144 Ω, the 10 kΩ measurement range will be used.

3. Obtain the Z coefficients A and B from the accuracy table (p.207) and then calculate the basic accuracy of Z. In the 1 kHz/10 kΩ range, the accuracy table (p.207) yields the values A = 0.05 and B = 0.02.

Using the basic accuracy formula (p.206) for 1 kΩ or more ranges,

$$Z \text{ accuracy} = \pm \left( 0.05 + 0.02 \times \left| \frac{10 \times 1.0144 \times 10^3}{10 \times 10^3} - 1 \right| \right) \cong \pm 0.05\%$$

4. Similarly, calculate the basic accuracy of θ.  
The accuracy table (p.207) yields the values A = 0.03 and B = 0.002.  
Using the basic accuracy formula (p.206) for 1 kΩ or more ranges,

$$\theta \text{ accuracy} = \pm \left( 0.03 + 0.02 \times \left| \frac{10 \times 1.0144 \times 10^3}{10 \times 10^3} - 1 \right| \right) \cong \pm 0.03^\circ$$

5. Calculate the range within which Z and θ values can be acquired from the basic accuracy.

$$Z_{\min} = 1.0144 \text{ k}\Omega \times \left( 1 - \frac{0.05}{100} \right) \cong 1.0139 \text{ k}\Omega$$

$$Z_{\max} = 1.0144 \text{ k}\Omega \times \left( 1 + \frac{0.05}{100} \right) \cong 1.0149 \text{ k}\Omega$$

$$\theta_{\min} = -78.69 - 0.03 = -78.72^\circ$$

$$\theta_{\max} = -78.69 + 0.03 = -78.66^\circ$$

6. Calculate the range within which Z and θ values can be acquired from the basic accuracy.  
(For more information about the Cs calculation formula, see "Appendix1 Measurement Parameters and Calculation formula" (p. A1).)

$$C_{s\min} = - \frac{1}{\omega \times Z_{\max} \times \sin \theta_{\min}} \cong 159.90 \text{ nF} \quad \dots -0.0625\%$$

$$C_{s\max} = - \frac{1}{\omega \times Z_{\min} \times \sin \theta_{\max}} \cong 160.10 \text{ nF} \quad \dots 0.0625\%$$

$$\omega = 2 \times \pi \times f \quad f = \text{frequency [Hz]}$$

7. Consequently, the Cs basic accuracy is ±0.0625%.

### Conversion table from C and L to $|Z|$

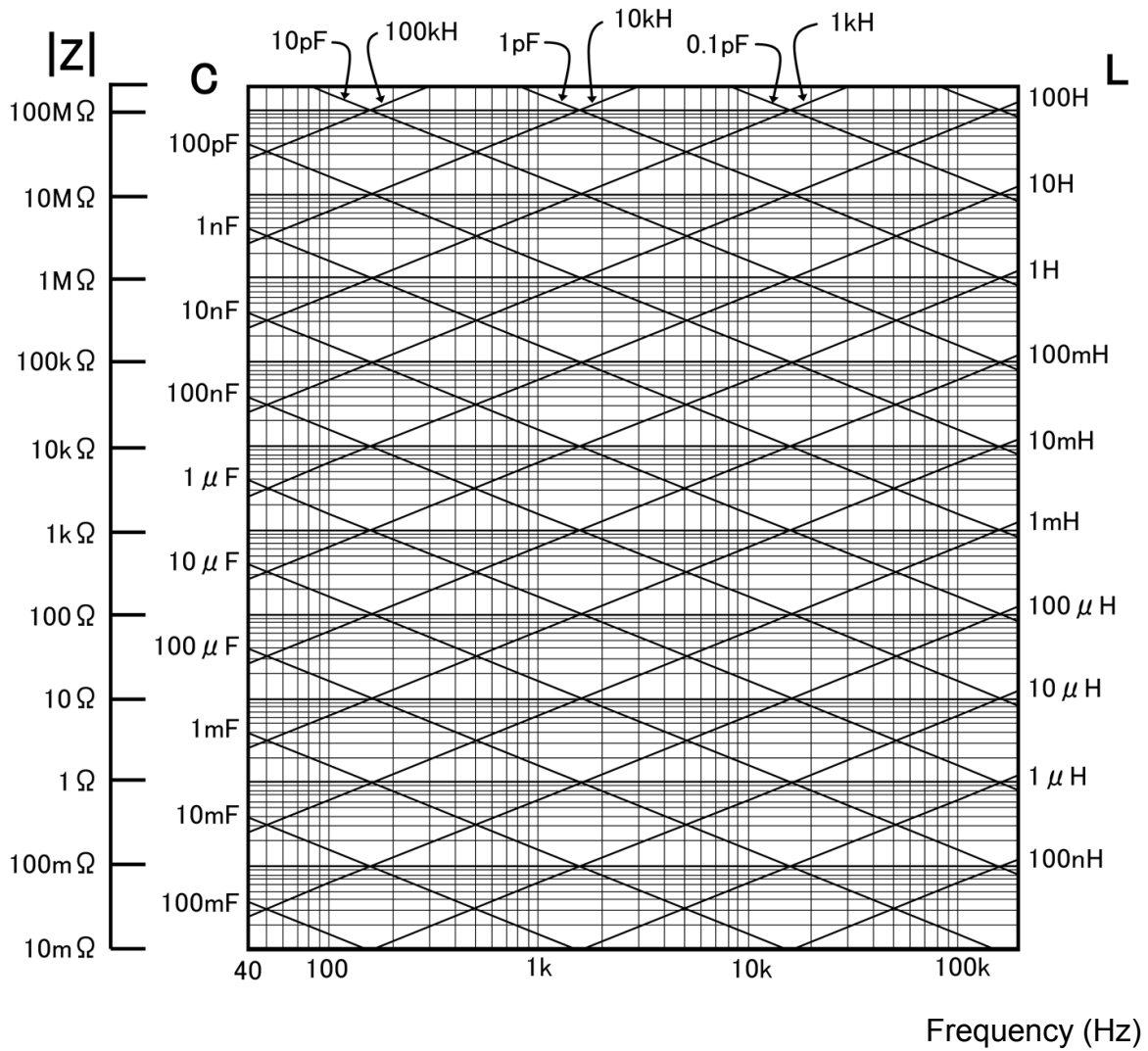

## 11.3 About Measurement Times and Measurement Speed

Measurement times differ depending on the measurement conditions. Refer to the following values.

### **NOTE**

All of the values are reference values. Note that they may differ depending on the conditions of use.

### Analog measurement signal (INDEX)

	FAST	MED	SLOW	SLOW2
DC (Line frequency 50 Hz)	43 ms	123 ms	203 ms	803 ms
DC (Line frequency 60 Hz)	37 ms	103 ms	203 ms	803 ms
40.000 Hz to 99.999 Hz	Tf s	2×Tf s	5×Tf s	40×Tf s
100.00 Hz to 300.00 Hz	Tf s	2×Tf s	5×Tf s	50×Tf s
300.01 Hz to 500.00 Hz	Tf s	2×Tf s	10×Tf s	200×Tf s
500.01 Hz to 1.0000 kHz	Tf s	5×Tf s	20×Tf s	300×Tf s
1.0001 kHz to 2.0000 kHz	2×Tf s	8×Tf s	40×Tf s	600×Tf s
2.0001 kHz to 3.0000 kHz	4×Tf s	12×Tf s	60×Tf s	1200×Tf s
3.0001 kHz to 5.0000 kHz	6×Tf s	20×Tf s	100×Tf s	2000×Tf s
5.0001 kHz to 10.000 kHz	10×Tf s	40×Tf s	200×Tf s	3000×Tf s
10.001 kHz to 20.000 kHz	20×Tf s	80×Tf s	400×Tf s	6000×Tf s
20.001 kHz to 30.000 kHz	50×Tf s	150×Tf s	600×Tf s	12000×Tf s
30.001 kHz to 50.000 kHz	50×Tf s	250×Tf s	1000×Tf s	20000×Tf s
50.001 kHz to 100.00 kHz	100×Tf s	400×Tf s	2000×Tf s	30000×Tf s
100.01 kHz to 200.00 kHz	200×Tf s	800×Tf s	4000×Tf s	60000×Tf s

Tolerance:  $\pm 5\% \pm 0.2 \text{ ms}$  Tf [s]=1÷ Measurement frequency

When the contact check function is enabled, the following times will be added to INDEX depending on the contact check timing:

Contact check timing	
BEFORE	2.5 ms
AFTER	1.0 ms
BOTH	3.0 ms

When the contact check setting is at [BEFORE], [BOTH] the analog measurement time will be delayed because automatically after contact check, the measurement will start only after the wait time for the trigger simultaneous output function has been activated.

The above values are the initial values of the wait time settings. They are for reference only.

## 11.3 About Measurement Times and Measurement Speed

### Measurement times (EOM)

Measurement times = INDEX + A + B + C + D + E

#### A. Calculation time

(no OPEN /SHORT/ LOAD compensation, HOLD range, no screen display, normal measurement)

	FAST	MED	SLOW	SLOW2
All frequencies	1.0 ms			

Tolerance:  $\pm 10\% \pm 0.1$  ms

#### B. OPEN/ SHORT/ LOAD compensation

OPEN/ SHORT/ LOAD compensation	
No	0.0 ms
Yes	MAX 0.4 ms

#### C. Measurement mode

Measurement mode	
Normal measurement	0.0 ms
Comparator measurement	MAX 0.4 ms
BIN measurement	MAX 0.8 ms

#### D. Screen Display

Screen Display	
OFF	0.0 ms
ON	MAX 0.3 ms

#### E. Saving to memory

Saving to memory	
Memory function ON/IN	MAX 0.4 ms
Memory function OFF	0.0 ms

### Wait time

- When the frequency is changed:  
When the frequency is changed, the wait time is 1 ms.
- When switching levels  
When the AC signal level is changed, the wait time is 1 ms.
- When switching ranges  
When the range is changed, the wait time is 1 ms.
- When DC resistance measurement  
When switching from AC measurement to DC resistance measurement, the wait time is 3 ms.
- When panel load  
After all changes have been made, there is a wait for the maximum value of the corresponding wait time above.

# Maintenance and Service

## Chapter 12

### 12.1 Inspection, Repair and Cleaning

Before requesting instrument repair or inspection, please read "Before returning for repair" (p.217) and Section "Error display" (p.222).

#### Inspection and Repair

**! WARNING** Do not attempt to modify, disassemble or repair the instrument; as fire, electric shock and injury could result.

#### **NOTE**

- The fuse is housed in the power unit of the instrument. If the power does not turn on, the fuse may be blown. If this occurs, a replacement or repair cannot be performed by customers. Please contact your dealer or Hioki representative.
- If damage is suspected, check the "Troubleshooting" section before contacting your dealer or Hioki representative.  
If damage is suspected, check the "Before returning for repair" (p.217) section before contacting your dealer or Hioki representative.  
However, in the following cases, immediately stop using the instrument, unplug the power cord and contact your dealer or Hioki representative.
- When the nature of the damage is clearly evident
- When measurement is impossible
- After long-term storage in adverse conditions such as high temperature or humidity
- After being subject to severe shock during transport
- After severe exposure to water, oil, or dust (internal insulation can be degraded by oil or water, causing increase hazard of electric shock or fire)

#### Replaceable Parts and Operating Lifetimes

Useful life depends on the operating environment and frequency of use. Operation cannot be guaranteed beyond the following periods.

For replacement parts, contact your dealer or Hioki representative.

Part	RemarksLife	Remarks
Electrolytic Capacitors	Approx. 10 years	The useful life of electrolytic capacitors depends on the operating environment. Periodic replacement is necessary.
Lithium battery	Approx. 10 years	The instrument contains a built-in backup lithium batter.The instrument incorporates a lithium battery for backup. The life of the backup battery is approximately 10 years. If the date and time greatly differ from the actual date and time when the power is turned on or a backup error appears at startup, it is time to replace the battery. Contact your dealer or Hioki representative.
LCD backlight (to half brightness)	Approx. 50,000 hours	Periodic replacement is necessary.

### Transporting the instrument

- Pack the instrument so that it will not sustain damage during shipping, and include a description of existing damage. We do not take any responsibility for damage incurred during shipping.
- Use the original packing materials when transporting the instrument, if possible.

### Cleaning

#### **NOTE**

- To clean the instrument, wipe it gently with a soft cloth moistened with water or mild detergent. Never use solvents such as benzene, alcohol, acetone, ether, ketones, thinners or gasoline, as they can deform and discolor the case.
  - Wipe the LCD gently with a soft, dry cloth.
  - Clean regularly to keep the vents from becoming blocked.
-

## 12.2 Troubleshooting

### Before returning for repair

In the event of the instrument malfunctioning, check the following items.

Symptom	Check Item, or Cause	Remedy and Reference
The display does not appear when you turn the power on.	Is the power cord unplugged? Is it properly connected?	Confirm that the power cord is properly connected. <b>See</b> (p.23)
Keys do not work.	Are the keys locked?	Disable the key lock. <b>See</b> (p.114)
	Is the instrument being remotely operated from an external device using communication cable?	Switch to the local state. <b>See</b> Communication Instruction Manual (LCR Application Disk)
The instrument doesn't work. You don't know how to operate the instrument.	Did you check the Instruction Manual?	Check the appropriate section of the Instruction Manual.
	Are you using the instrument as part of an automated system?	Consult the administrator or manager of the instrument or the automated system containing the instrument.
Cannot print.	Is the recording paper loaded properly? Are the printer settings correct? (Communication speed, interface, etc.) Are the instrument and printer properly connected with a suitable cable?	<b>See</b> (p.195)
Nothing is displayed on the screen.	The LCD may be set to automatically turn off after a set time. Is the instrument in the standby state?	Press a key to cancel the standby state. <b>See</b> (p.26), (p.107)
Key response and screen drawing are slow.	Is the measurement value automatic output function enabled?	When the measurement value automatic output function is enabled, key response and screen drawing may become slow in order to give priority to measurement and measurement value output. <b>See</b> Communication Instruction Manual (LCR Application Disk)

Symptom	Check Item, or Cause	Remedy and Reference
The measurement values are exhibiting excessive variation.	Is the signal level setting too low?	Change the signal level setting. <b>See</b> (p.37)
	Is an error from "12.3 Error display" (p. 222) being displayed?	Check the item indicated by the error display, address the cause, and then perform measurement. <b>See</b> (p.222)
		If <b>REF VAL</b> is being displayed, check measurement conditions such as the frequency and signal level and select conditions for which <b>REF VAL</b> will not be displayed. <b>See</b> (p.37)
	Are you using the instrument in a high-noise environment?	If you are using the instrument in a high-noise environment, consider taking the following measures: <ul style="list-style-type: none"> <li>• Use guarding.</li> <li>• Implement anti-noise measures.</li> <li>• Separate the sample, measurement cables, and instrument from the source of the noise (motor, inverter, electromagnetic switch, power line, equipment generating sparks, etc.) or perform the measurement in a separate room.</li> <li>• Plug the instrument into a grounded outlet.</li> <li>• Use a separate power supply from the device that is generating the noise.</li> </ul>
	Are you using a cable that you made yourself?	<ul style="list-style-type: none"> <li>• Check the wiring method and correct it if necessary.</li> <li>• Use a designated cable of the same length as the cable length setting.</li> </ul>
	Is the connection cable too long?	Use a designated cable of the same length as the cable length setting. <b>See</b> (p.157)
	Are you using a 2-terminal connection to perform measurement?	Two-terminal connections are susceptible to the influence of contact resistance. When possible, use a 4-terminal connection to the sample's electrodes to perform measurement.
		Add a wait time to allow contact to stabilize before measurement.
Did you perform open and short compensation?	Perform open and short compensation properly. <b>See</b> (p.125), (p.136)	



Symptom	Check Item, or Cause	Remedy and Reference
You are unable to perform measurement properly.	Is an error from "12.3 Error display" (p. 222) being displayed?	Check the item indicated by the error display, address the cause, and then perform measurement. <b>See</b> (p.222)
	Is <b>OVERFLOW</b> or <b>UNDERFLOW</b> being displayed? <b>See</b> "12.3 Error display" (p. 222)	If the range is not appropriate: Change to an appropriate range or perform measurement using auto ranging.  If there is a break or short in the wiring: Check the wiring and perform measurement with the correct wiring connections.
	Is an error such as <b>MC A</b> ■ or <b>MC B</b> ■ being displayed (contact error)? <b>See</b> "12.3 Error display" (p. 222)	Proper contact is not being made with the sample. Check the points of contact with the sample. Check the wiring for a break or defective contact. <b>See</b> (p.103)  If you are using the instrument in a high-noise environment, consider taking the following measures: • Use guarding. • Separate the sample, measurement cables, and instrument from the source of the noise (motor, inverter, electromagnetic switch, power line, equipment generating sparks, etc.) or perform the measurement in a separate room. • Plug the instrument into a grounded outlet. • Use a separate power supply from the device that is generating the noise.
	Are you measuring an element that generates voltage on its own, for example a battery?	If there is a high DC voltage, you may damage the instrument. Avoid measuring the sample.
	Are you measuring an element on a printed circuit board?	• You can measure an element on a printed circuit board if the target element is isolated from external connections. However, if the target element is connected to other components or external circuitry, you will not be able to obtain a proper measurement. • You may be unable to measure components in circuits that are generating a voltage or to which a voltage is being applied, for example because they are energized.
	Is a high-impedance element which is influenced by noise being measured?	Use guarding. <b>See</b> ( p.A3)
The measurement values differ when a standard resistor, standard capacitor, or other known test sample is measured.	Do the measurement conditions of the known test sample and measurement conditions of the instrument match?	Make sure the measurement conditions match.
	Did you perform open and short compensation properly?	Perform open and short compensation again. <b>See</b> (p.125), (p.136)
	Is load compensation set?	Turn load compensation off. <b>See</b> (p.145)
AUTO ranging is unable to determine a range.	Is the wait time for from connecting the test sample until performing measurement insufficient?	Ensure there is an appropriate trigger delay and trigger synchronization output wait time. <b>See</b> (p.56)
	Is a high-impedance element which is influenced by noise being measured?	Use guarding. <b>See</b> ( p.A3)

## 12.2 Troubleshooting

Symptom	Check Item, or Cause	Remedy and Reference
Open compensation or short compensation resulted in an error.	Is the open or short compensation wiring correct?	Perform open compensation or short compensation with the proper wiring.
	Are you using the instrument in a high-noise environment?	<p>If you are using the instrument in a high-noise environment, consider taking the following measures:</p> <ul style="list-style-type: none"> <li>• Use guarding.</li> <li>• Implement anti-noise measures.</li> <li>• Separate the sample, measurement cables, and instrument from the source of the noise (motor, inverter, electromagnetic switch, power line, equipment generating sparks, etc.) or perform the measurement in a separate room.</li> <li>• Plug the instrument into a grounded outlet.</li> <li>• Use a separate power supply from the device that is generating the noise.</li> </ul>
An error beep sound is emitted continuously.	Is the measurement value automatic output function enabled?	<p>When the measurement value automatic output function is enabled, a send error occurs on the measuring instrument side if the receive operation is not performed on the PC side, and a send error sound is emitted continuously when, for example, there is an internal trigger. Perform the receive operation on the PC side and then perform measurement on the measuring instrument side, or disable the measurement value automatic output function.</p> <p><b>See</b> Communication Instruction Manual (LCR Application Disk)</p>
No EXT I/O output signal can be obtained.	Do you know what type of output circuit is being used?	<p>The instrument's EXT I/O functionality generates open collector output. Connect the wiring properly to the open collector.</p> <p><b>See</b> (p.177)</p>
You are unable to send and receive data using RS-232C.	Are you using a straight cable?	Use a cross cable.
	Are you using the wrong COM port?	<p>Check whether the computer's settings match the connected COM port. Connect the cable to the proper COM port.</p> <p>Check the computer's settings. The COM port may be selected at the operating system, driver, or application level. Check all of these settings.</p>
	The computer has no COM port.	Consider using a commercially available USB/RS-232C conversion cable.
	You don't know which command is wrong.	Using an application such as Windows HyperTerminal, check commands using manual input.
	The instrument is unable to communicate with the application.	<p>Check whether the instrument is turned on.</p> <p>Turn on the instrument and complete any interface connections before launching the computer application.</p>

### When no apparent cause can be established

Perform a system reset.

This will return all settings to their factory defaults.

**See** (p.118)

## Full Reset Procedure

Performing a full reset will restore all of the settings to the factory default settings. Only perform a full reset in the following cases.

- When the normal reset screen cannot be displayed because of a problem with the instrument. (After the full reset, perform a self check to confirm that there are no problems. (p.173))
- When you have forgotten the passcode for the key lock.

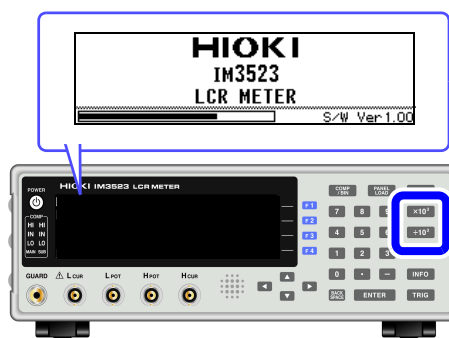











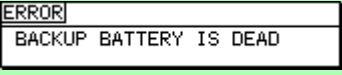

- 1** Connect the power cable.
- 2** Press the POWER button.
- 3** Press and hold the  $\times 10^3$  and  $\div 10^3$  keys simultaneously while the opening screen is displayed.
- 4** The full reset is complete when a beeping sound is emitted.

If the instrument still does not operate normally after the full reset, it needs to be repaired. Contact your dealer, or a Hioki representative if you are not sure where the instrument was purchased.

**NOTE** Before performing a full reset, please remove the connection of the test sample to be measured first.

## 12.3 Error display

When any of the following indications appear on the screen, check the corresponding reference page.

Error display	Description	Remedy and Reference
	The life of the RAM backup battery has ended.	The instrument needs to be repaired. Contact your dealer or Hioki representative.
	This is displayed when a measurement value is outside of the guaranteed accuracy range.	Increase the measurement signal level or change the measurement range to one that matches the impedance of the element to be measured. <a href="#">See</a> (p.37), (p.43)
	This is displayed when load compensation is enabled and the load compensation frequency does not match the current measurement frequency.	When load compensation: Match the current measurement frequency to the compensation frequency. <a href="#">See</a> (p.145)
	This is displayed when constant voltage measurement and constant current measurement cannot be performed.	When constant voltage measurement or constant current measurement: Reduce the constant voltage level or constant current level. <a href="#">See</a> (p.39)
	This is displayed when a signal level that is lower than the set value is applied to the test sample as a result of the voltage/current limit value setting.	Set the limit value again or change the measurement signal level so that the limit value is not exceeded. <a href="#">See</a> (p.41)
	This is displayed when load compensation is enabled and a load compensation condition other than the frequency does not match the current measurement condition.	Match the current measurement condition to the load compensation condition. <a href="#">See</a> (p.145)
	This is displayed when the set number of measurement results have been stored in the instrument's memory.	Load measurement values stored in the instrument's memory with the memory function or clear the memory. <a href="#">See</a> (p.97)
	This is displayed when a measurement value is outside of the screen display range.	Change the measurement range to one that matches the impedance of the element to be measured. <a href="#">See</a> (p.43)
	This is displayed when measurement does not end because of an internal circuit error.	The instrument needs to be repaired. Contact your dealer or Hioki representative.
	This is displayed when a measurement value is at or above the upper limit value of the auto ranging range.	Change the measurement range to a high-impedance range. <a href="#">See</a> (p.43)
	This is displayed when a measurement value is at or below the lower limit value of the auto ranging range.	Change the measurement range to a low-impedance range. <a href="#">See</a> (p.43)
	This is displayed when the HPOT, HCUR, LPOT, or LCUR terminal is not connected after measurement, for example due to a break in wiring.	Check the connection of each terminal. <a href="#">See</a> (p.24)
	This is displayed when the LPOT or LCUR terminal is not connected after L measurement, for example due to a break in wiring.	Check the connection of each terminal. <a href="#">See</a> (p.24)

Error display	Description	Remedy and Reference
NC A H	This is displayed when the H <sub>POT</sub> or H <sub>CUR</sub> terminal is not connected after H measurement, for example due to a break in wiring.	Check the connection of each terminal. <a href="#">See</a> (p.24)
NC B HL	This is displayed when the H <sub>POT</sub> , H <sub>CUR</sub> , L <sub>POT</sub> , or L <sub>CUR</sub> terminal is not connected prior to measurement, for example due to a break in wiring.	Check the connection of each terminal. <a href="#">See</a> (p.24)
NC B L	This is displayed when the L <sub>POT</sub> or L <sub>CUR</sub> terminal is not connected prior to L measurement, for example due to a break in wiring.	Check the connection of each terminal. <a href="#">See</a> (p.24)
NC B H	This is displayed when the H <sub>POT</sub> or H <sub>CUR</sub> terminal is not connected prior to H measurement, for example due to a break in wiring.	Check the connection of each terminal. <a href="#">See</a> (p.24)
Hi Z	This is displayed when a measurement result is high in relation to the judgment reference set for the HIGH-Z reject function.	Check the connection of each terminal. <a href="#">See</a> (p.105)

# 12.4 Disposing of the Instrument

The instrument uses lithium battery as a power source for storing measurement conditions. When disposing of this instrument, remove the lithium battery and dispose of battery and instrument in accordance with local regulations.

**! WARNING**

- To avoid electric shock, turn off the power switch and disconnect the power cord and measurement cables before removing the lithium battery.
- Battery may explode if mistreated. Do not short-circuit, recharge, disassemble or dispose of in fire.
- Keep batteries away from children to prevent accidental swallowing.

**! CAUTION** If the protective functions of the instrument are damaged, either remove it from service or mark it clearly so that others do not use it inadvertently.

## Lithium Battery Removal

**Required tools:**

- One Philips screwdriver
- One tweezers (to remove the lithium battery)

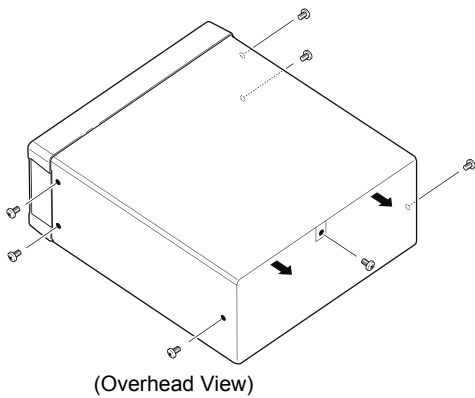

- 1** Verify that the power is off, and remove the connection cables and power cord.
- 2** Remove the six screws from the sides and one screw from the rear.
- 3** Remove the cover.
- 4** Insert the tweezers between the battery and battery holder as shown in the diagram below and lift up the battery.

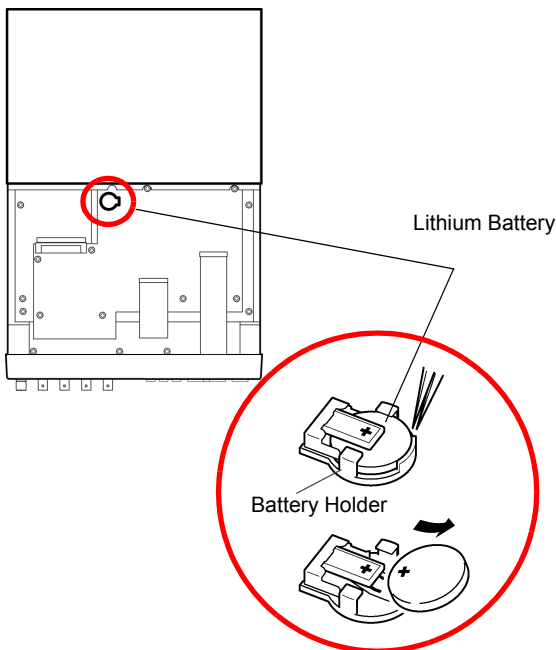

**! CAUTION**  
Take care not to short the + and -. Doing so may cause sparks.

**CALIFORNIA, USA ONLY**  
Perchlorate Material - special handling may apply.  
See [www.dtsc.ca.gov/hazardouswaste/perchlorate](http://www.dtsc.ca.gov/hazardouswaste/perchlorate)

# Appendix

## Appendix1 Measurement Parameters and Calculation formula

In general, impedance  $Z$  is used to evaluate the characteristics of, for example, circuit components. The IM3523 measures voltage and current vectors for circuit components relative to an AC signal at the set measurement frequency and uses those values to calculate the impedance  $Z$  and phase difference  $\theta$ . The impedance  $Z$  can be expanded on a complex plane to calculate the following values:

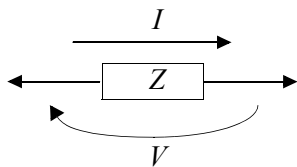

$$Z = R + jX$$

$$\theta = \tan^{-1} \frac{X}{R}$$

$$|Z| = \sqrt{R^2 + X^2}$$

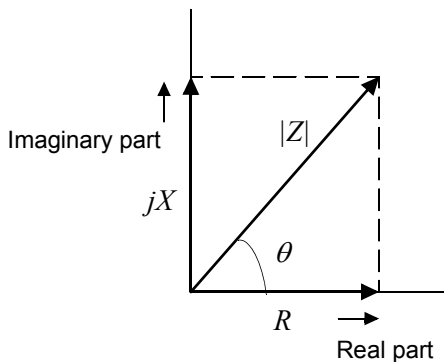

- $Z$  : Impedance( $\Omega$ )
- $\theta$  : Phase angle (deg)
- $R$  : Resistance( $\Omega$ )
- $X$  : Reactance( $\Omega$ )
- $|Z|$  : Absolute value of impedance( $\Omega$ )

Furthermore, admittance  $Y$  that is the reciprocal of impedance  $Z$  can also be used depending on the characteristics of circuit components. As in the case of impedance  $Z$ , the following values can also be obtained from admittance  $Y$  by rotating the admittance  $Y$  around the complex plane.

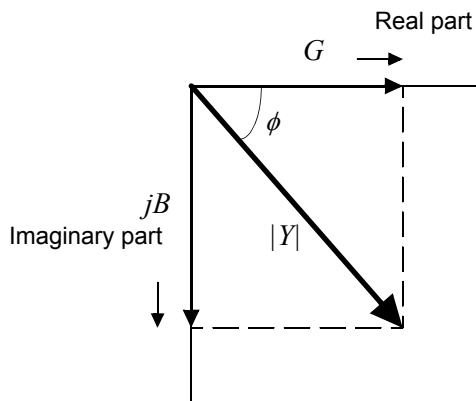

$$Y = G + jB$$

$$\phi = \tan^{-1} \frac{B}{G}$$

$$|Y| = \sqrt{G^2 + B^2}$$

- $Y$  : Admittance (S)
- $\phi$  : Phase angle (deg) =  $-\theta$
- $G$  : Conductance (S)
- $B$  : Susceptance (S)
- $|Y|$  : Absolute value of admittance (S)

# A2

## Appendix1 Measurement Parameters and Calculation formula

The instrument uses the following equations to calculate the components listed below from the voltage  $V$  flowing across the measurement sample's terminals, the resulting current  $I$  that passes through the sample, the phase difference  $\theta$  relative to the voltage  $V$  and current  $I$ , and the measurement frequency's angular velocity  $\omega$ .

**NOTE** The phase angle  $\theta$  is displayed using the impedance  $Z$  as the reference. When performing measurements using admittance  $Y$  as the reference, the sign of the impedance  $Z$  phase angle  $\theta$  will be reversed.

Item	Series equivalent circuit mode	Parallel equivalent circuit mode
Z	$ Z  = \frac{V}{I} (= \sqrt{R^2 + X^2})$	
Y	$ Y  = \frac{I}{ Z } (= \sqrt{G^2 + B^2})$	
R	$R_S = ESR =  Z  \cos \theta$	$R_P = \frac{I}{ Y  \cos \phi} (= \frac{I}{G})^*$
X	$X =  Z  \sin \theta$	_____
G	_____	$G =  Y  \cos \phi^*$
B	_____	$B =  Y  \sin \phi^*$
L	$L_S = \frac{X}{\omega}$	$L_P = -\frac{I}{\omega B}$
C	$C_S = -\frac{I}{\omega X}$	$C_P = \frac{B}{\omega}$
D	$D = \frac{\cos \theta}{ \sin \theta }$	
Q	$Q = \frac{ \sin \theta }{\cos \theta} (= \frac{I}{D})$	

\*  $\phi$  : phase angle of admittance  $Y$  ( $\phi = -\theta$ )

$L_S, C_S, R_S$  : The measured values of  $L, C,$  and  $R$  in series equivalent circuit mode.

$L_P, C_P, R_P$  : The measured values of  $L, C,$  and  $R$  in parallel equivalent circuit mode.



## Appendix2 Measurement of High Impedance Components

The measured value obtained when testing a high impedance element (such as, for example, a resistor with resistance higher than 100 k $\Omega$ ) is sometimes unreliable, because such an element is vulnerable to the effects of external interference and the like. In this case, reliable testing can be performed by the use of guarding, that is, connecting a metallic plate to the GUARD terminal and carrying out the measurement on the metallic plate.

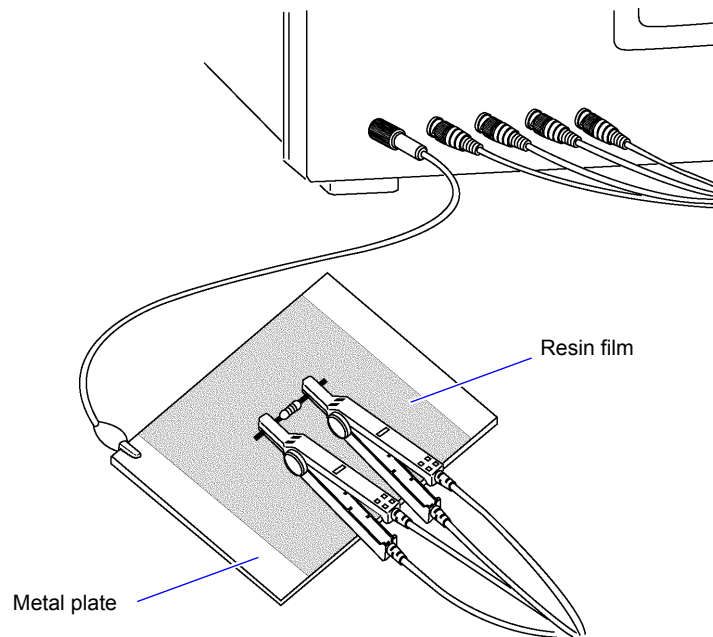

When measuring components on a metal plate, use, for example, resin film as insulation to ensure terminals and the like are not short-circuited.

**NOTE** Open circuit compensation is high impedance measurement, so be sure to use the shielding process. If it is not used, the compensation values may become unstable and affect the measurement values.

### Appendix3 Measuring In-circuit Elements

Measure an in-circuit component after providing guarding.

$$R = R_2 \cdot \frac{R_3 + R_4}{R_2 + R_3 + R_4}$$

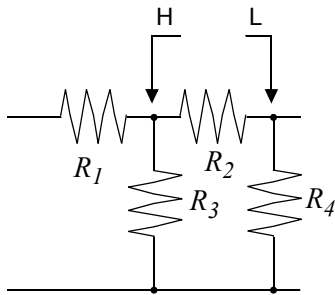

Referring to the following figure, when measuring a resistance value for the resistor  $R_2$ , even if the tips of the two probes are contacted against the ends of the resistor  $R_2$ , considering the sum of the current flowing through the resistor  $R_2$  and the current flowing through the resistors  $R_3$  and  $R_4$ , what is obtained is the resistance value for the parallel combination:

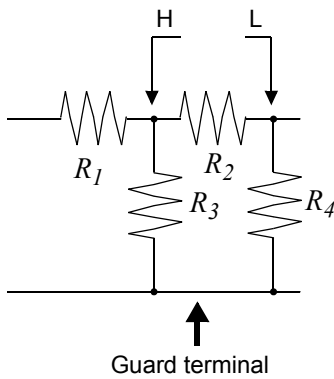

If as shown in the next figure a guard terminal is used, the current flowing through the resistors  $R_3$  (not flowing through  $R_4$ ) is absorbed by this guard terminal, so that the resistance value for the resistor  $R_2$  is accurately measured.

#### **NOTE**

- The accuracy of measurement will not be improved in cases where for example  $R_2 \gg R_3$  and  $R_3$  is close to zero.
- As shown in the figure below, it is not possible to use this type of separation process for testing of the impedance values of two resistors or other elements of identical types which are connected in parallel, or for testing of the impedance values of a coil and a capacitor which are connected in parallel.

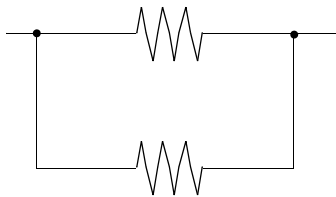

Two resistors in parallel

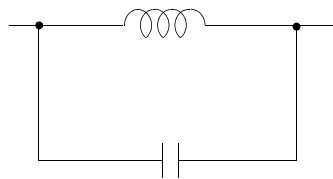

Coil and capacitor in parallel

## Appendix4 Countermeasures Against Incorporation of External Noise

This instrument is designed to be resistant to errors caused by interference from the test cables or the power supply line. However, if the level of the interference is particularly large, this can cause measurement errors or faulty operation.

Refer to the examples given below for examples of countermeasures which can be taken against interference which has caused faulty operation etc.

### Appendix4.1 Countermeasures Against Incorporation of Noise from the Power Line

You can use the following countermeasures to reduce the effect of noise being incorporated from the power line.

#### Grounding Using a Protective Ground Wire

This instrument is structured so that the ground wire of the power cable can be used as protective grounding for the instrument. Protective grounding plays an important role in not only the prevention of electrical accidents but also the use of an internal filter to eliminate the incorporation of noise from the power line. Use the supplied power cord.

#### Attaching a Noise Filter to the Power Line

Connect a commercial plug-in noise filter to the power outlet and then connect the instrument to the output of the noise filter in order to suppress the incorporation of noise from the power line. Plug-in noise filters are commercially available from various specialist manufacturers.

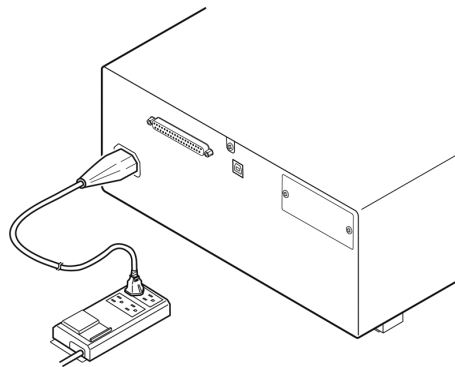

### Attaching an EMI Suppression Ferrite Core to the Power Cord

Pass the power cord through a commercially available EMI suppression ferrite core and secure the core as close as possible to the AC power inlet of the instrument in order to suppress the incorporation of noise from the power line.

Suppression is even more effective if you also attach an EMI suppression ferrite core close to the power plug of the power source.

If a toroidal ferrite core or split ferrite core with a large enough internal diameter is used, the amount of noise suppression can be increased by passing the power cord through the core several times.

EMI ferrite cores and ferrite beads are commercially available from various specialist manufacturers.

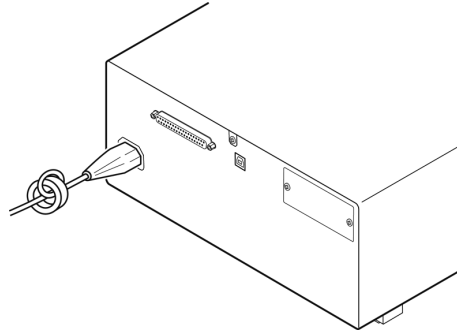

### Appendix4.2 Countermeasures Against Noise from the measurement Cables

If interference is producing noise in the measurement cables, its influence can be moderated by the following countermeasure.

#### Fitting an anti-interference ferrite core on the measurement cables

Pass the test cables through a commercially available anti-interference ferrite core, and fix it close to the measurement terminals, so as to suppress noise from the measurement cables.

Moreover, if the internal diameter of the ferrite core allows, winding the measurement cables several times around the ferrite core (as with the power cord as described above) may further reduce the amount of noise.

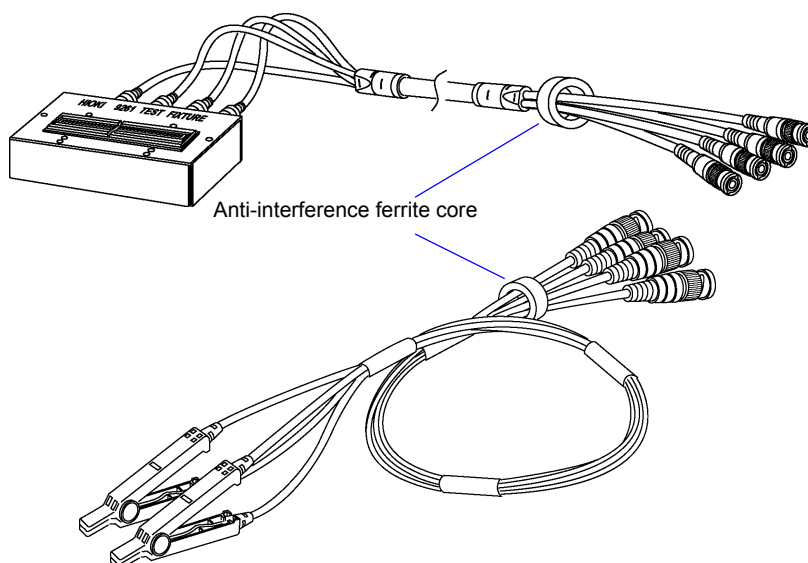

## Appendix5 Supplying DC Bias

Supplying DC bias means that a DC voltage is supplied as a bias to a sample for test whose characteristics are voltage dependent, such as an electrolytic capacitor or a ceramic capacitor.

Further, a DC current can be supplied as a bias to a sample for test whose characteristics are current dependent, such as a choke coil.

This instrument does not provide a DC bias input terminal. DC bias should be applied using the method described below.

**! CAUTION** A voltage must not be applied to the measurement terminals of the instrument from an external source.  
If a voltage is applied from an external source, the instrument may be damaged.

### Appendix5.1 How to Supply a DC Bias Voltage

When you want to apply a DC voltage bias, refer to the following explanation.  
Apply a DC voltage bias to a capacitor or other test sample as shown below.

DC Bias Voltage Circuit

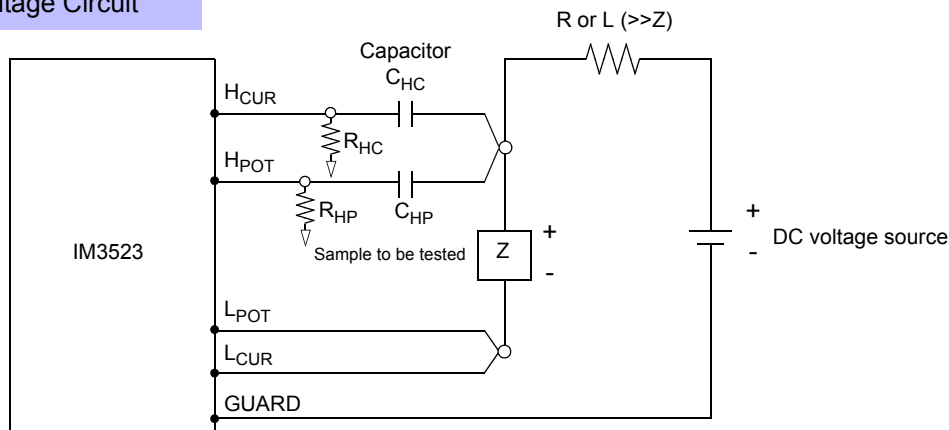

- Use a resistance (R) or inductance (L) which has a large enough impedance with reference to the sample under test (Z).
- A  $H_{CUR}$  side capacitor must have a small enough impedance (i.e. a large enough capacitance) relative to the output resistance ( $100\ \Omega$ ) while a  $H_{POT}$  capacitor must have a small enough impedance to the  $R_{HP}$ .
- Be careful about the polarity when connecting together the probes, the sample to be tested, and the DC voltage source.
- It takes a little time for the DC voltage which is being supplied to the sample under test to reach the set voltage, so you should wait for a certain stabilization time period (which depends upon the sample) before performing.
- After testing is completed, drop the voltage of the DC voltage source to zero, and remove the sample under test from the probes after having discharged any electric charge which may have built up.
- If you have removed the sample under test from the probes without first having discharged the accumulated electric charge, you should be careful to do so immediately.

**! CAUTION**

- In order to avoid electric shock accident, be absolutely sure not to touch the test terminals while the DC bias voltage is being supplied to them.
- If you disconnect the sample under test from the test terminals with the DC bias voltage still being supplied, then the test sample is left charged, which is very dangerous. In order to avoid electric shock.
- Do not short circuit between the clips of the test probes with the DC bias voltage still being supplied. Doing so may damage the probes or cause a short circuit accident.
- When measuring the element whose DC resistance is not high enough, DC current will flow to the main instrument and the measurement will not be performed properly.

## Appendix5.2 How to Supply a DC Bias Current

When you want to apply a DC current bias, refer to the following explanation.

With regards to a DC current bias for a transformer, choke coil, or other test sample, configure the external bias circuit as shown below.

DC Bias Current Circuit

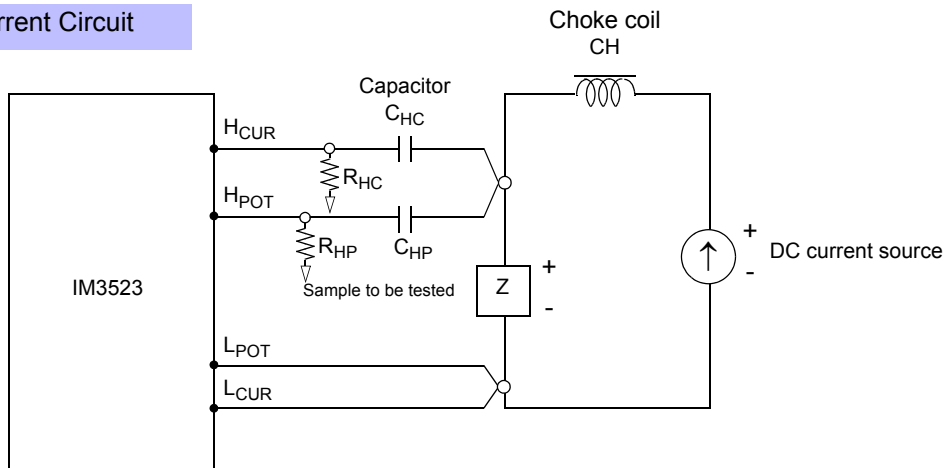

- Connect the sample to the measuring probe and then gradually raise the voltage of the DC source to the specified DC bias level. To disconnect the sample, gradually reduce the voltage of the DC source until the DC bias supplied to the sample is decreased to zero. You may disconnect the sample after this is achieved.
- Use a choke coil (CH) which has a large enough impedance with reference to the sample under test (Z).
- A H<sub>CUR</sub> side capacitor must have a small enough impedance (i.e. a large enough capacitance) relative to the output resistance (100 Ω) while a H<sub>POT</sub> capacitor must have a small enough impedance to the R<sub>HP</sub>.
- Be careful about the polarity when connecting together the probes, the sample to be tested, and the DC current source.
- Be careful not to magnetically saturate the choke coil (CH) with the DC bias current.
- It takes a little time for the DC current which is being supplied to the sample under test to reach the set value, so you should wait for a certain stabilization time period (which depends upon the sample) before performing testing. Be careful, because if you perform testing before this stabilization time period has elapsed, the results will not be reliable.

### **CAUTION**

- In order to avoid electric shock accident, be absolutely sure not to touch the test terminals while the DC bias is being supplied to them.
- Due to the inductance of the coil and the sample, counter electromotive force is generated when the sample is removed or inserted with the DC bias supplied. This may result in damage to the instrument or to the DC source.
- When measuring the element whose DC resistance is high (incl. open state), a high voltage occurred on the H side may cause damage on the main instrument.

## Appendix6 The Residual Charge Protection Function

The instrument has been enhanced by the incorporation of a residual charge protection function. If by mistake a charged capacitor is connected to the measurement terminals, this function protects the internal circuitry of the instrument from discharge of such residual charge.

The maximum voltage from which the instrument can be protected by this function is determined from the capacitance value of the sample under test by the following equation:

$$V = \sqrt{\frac{10}{C}}$$

V : voltage [V] (maximum 400 VDC)

C : capacitance [F]

### **CAUTION**

- The quoted maximum voltage from which the instrument can be protected by this function is for reference purposes only, and is not a guaranteed value. There may be danger of damage to the instrument, depending upon the operational circumstances and upon how often such charged capacitors are connected. In general, you should not rely upon this protection function; be sure to discharge charged capacitors properly before connecting them to the test terminals.
- The residual charge protection function is for protection of the instrument against the discharge of voltage present in charged capacitors, and is not capable of protecting the instrument against DC voltage which is constantly applied such as a superimposed DC voltage. If this is done, there is a danger of damage to the instrument.  
[See Appendix5 Supplying DC Bias \(p.A7\)](#)

Relationship of capacitance and residual voltage from which the LCR meter can be protected.

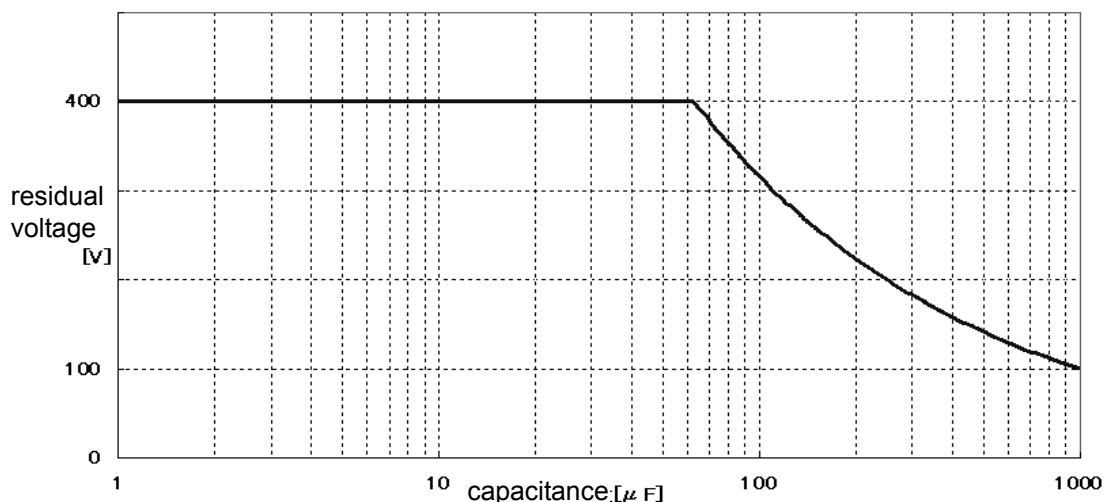

### Appendix7 Series Equivalent Circuit Mode and Parallel Equivalent Circuit Mode

The instrument measures the current flowing to the test sample and the voltage at both ends of the test sample, and determines  $Z$  and  $\theta$ . Other measurement items such as  $L$ ,  $C$ , and  $R$  are calculated from  $Z$  and  $\theta$ . At this time, the mode for calculation becomes series equivalent circuit mode if the resistance components for  $C$  (or  $L$ ) are assumed to be in series, and the mode becomes parallel equivalent circuit mode if the resistance components for  $C$  (or  $L$ ) are assumed to be in parallel. It is, therefore, necessary to select the correct equivalent circuit mode to reduce errors because the calculation expression differs for series equivalent circuit mode and parallel equivalent circuit mode.

Generally, for measurement of a low impedance device (approx. less than  $100\ \Omega$ ) like a large capacitance capacitor or a low inductance, a series equivalent circuit mode will be selected. While, for a high impedance device (approx. more than  $10\ \text{k}\Omega$ ) like a small capacitance capacitor or a high inductance, a parallel equivalent circuit mode will be selected. When you are not sure about selection of circuit mode, please ask the parts maker. (ex. a impedance approx. between  $100\ \Omega$  and  $10\ \text{k}\Omega$ )

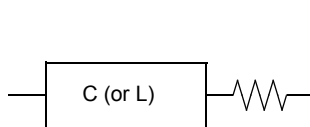

Series equivalent circuit

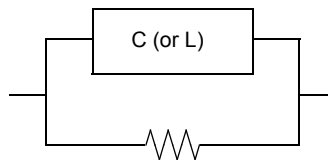

Parallel equivalent circuit

**NOTE** Because measurement value in each equivalent circuit mode is obtained through calculation, measurement values of both modes can be displayed. However, please note that the appropriate equivalent circuit depends on the test sample.



## Appendix8 Open Circuit Compensation and Short Circuit Compensation

The residual impedance component of the test fixture can be considered in terms of an equivalent circuit as shown in the figure. Further, because the measured value  $Z_m$  for impedance includes this residual component, therefore, in order to obtain the genuine impedance value, it is necessary to compensate the measured value in terms of the open circuit impedance residual component and the short circuit residual component, which accordingly must be obtained.

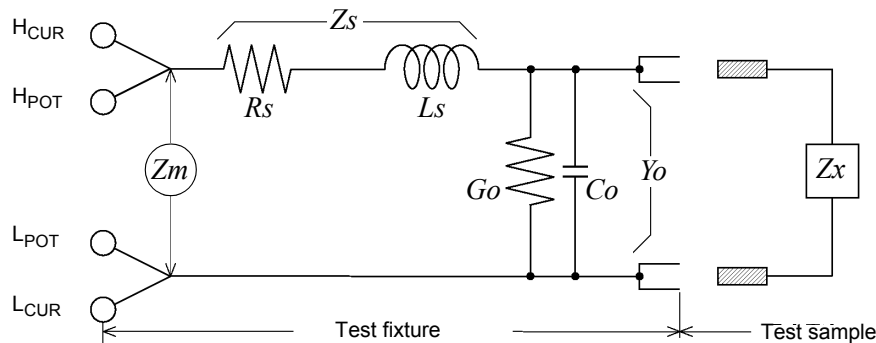

$Z_x$ : true value	$R_s$ : residual resistance
$L_s$ : residual inductance	$G_o$ : residual conductance
$C_o$ : floating capacitance value	$Z_s$ : short circuit residual component
$Y_o$ : open circuit residual component	$Z_m$ : measured value

In this case, for the measured value  $Z_m$ :

$$Z_m = Z_s + \frac{1}{Y_o + \frac{1}{Z_x}}$$

The residual components can be determined in the following manner:

- Open circuit compensation  
The terminals of the test fixture are left separated (open circuited). Because the short circuit residual component  $Z_s$  is now zero, therefore the open circuit residual component  $Y_o$  can be determined.
- Short circuit compensation  
The terminals of the test fixture are connected together (short circuited). Because the open circuit residual component  $Y_o$  is now zero, therefore the short circuit residual component  $Z_s$  can be determined.

These residual components thus obtained are recorded as compensation values, and the compensation process may then be performed by substituting them into the above equation.

**NOTE** The determination of test range is performed according to the measured value  $Z_m$  for impedance. Therefore it may happen that testing cannot be performed, when HOLD is on, if the test range is determined merely according to the value of impedance of the sample under test. In this case, you should set the test range in consideration both of the impedance of the test sample and also of the residual impedance components of the test fixture.

# A12

## Appendix8 Open Circuit Compensation and Short Circuit Compensation

Deviations in the measured values can become comparatively large in the following cases:

- If only short circuit compensation has been performed.

With short circuit compensation only having been performed, since no compensation can be performed in terms of the open circuit residual component  $Y_o$  (which is not available), thereby deviation in the resultant values will become large if the value of that open circuit residual component  $Y_o$  is relatively large.

- If only open circuit compensation has been performed.

With open circuit compensation only having been performed, since no compensation can be performed in terms of the short circuit residual component  $Z_s$  (which is not available), thereby deviation in the resultant values will become large if the value of that short circuit residual component  $Z_s$  is relatively large.

In order to avoid this sort of thing, be sure always to perform both short circuit compensation and also open circuit compensation.

# Appendix9 Rack Mounting

Rack mounting brackets can be attached to the instrument.



**WARNING**

Observe the following precautions regarding the mounting screws to avoid instrument damage and electric shock accidents.

- When installing the Rack Mounting Plate, the screws must not intrude more than 3.5 mm into either side of the instrument.
- When removing the Rack Mounting Plate to return the instrument to stand-alone use, replace the same screws that were installed originally.  
(Feet: M3 × 6 mm, Sides: M4 × 6 mm)

## Rack Mounting Plate Template Diagram and Installation Procedure

### Rack Mounting Plate (EIA)

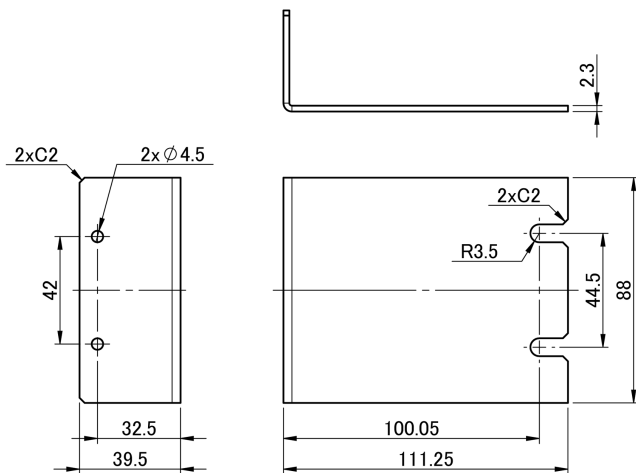

### Spacer (Two Required)

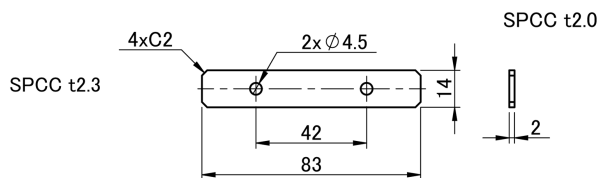

### Rack Mounting Plate (JIS)

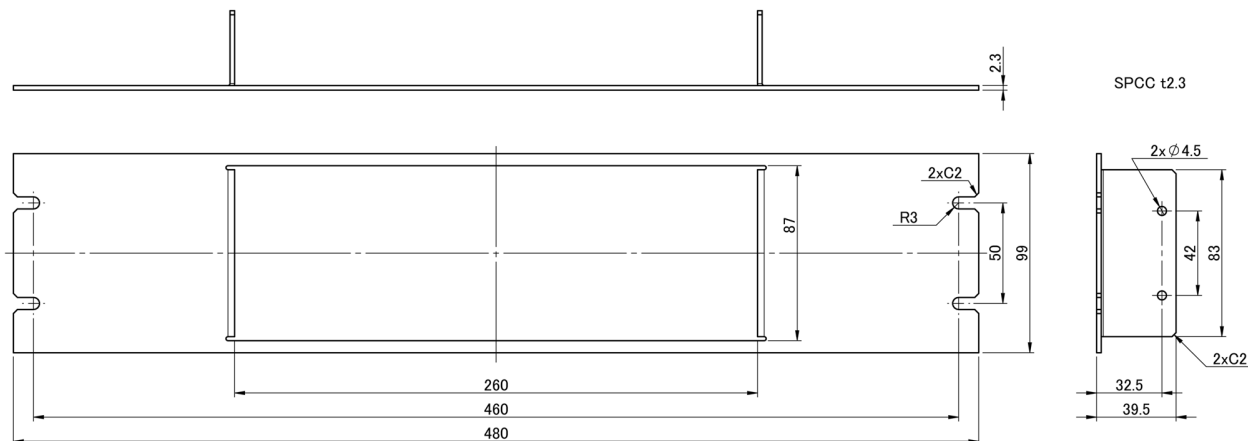

# A14

## Appendix9 Rack Mounting

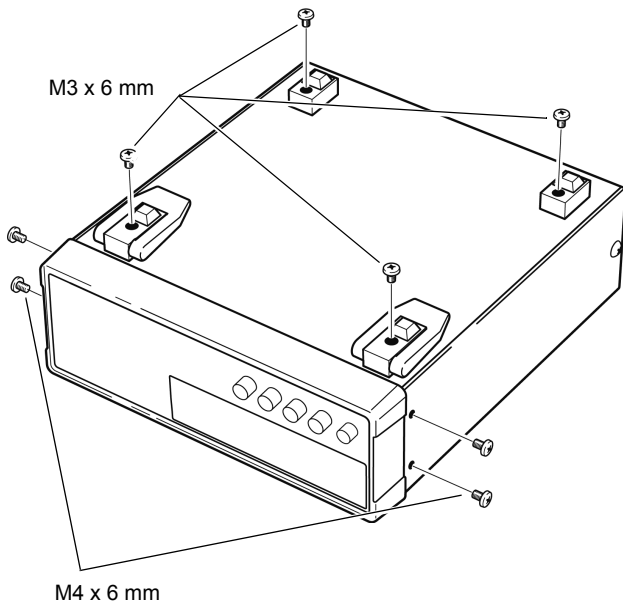

- 1 Remove the feed from the bottom of the instrument, and the screws from the sides (four near the front).

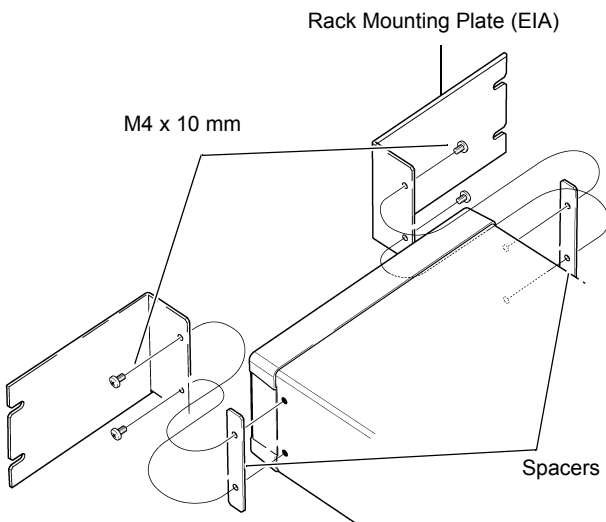

- 2 Installing the spacers on both sides of the instrument, affix the Rack Mounting Plate with the M4 x 10 mm screws.

**When installing into the rack, reinforce the installation with a commercially available support stand.**

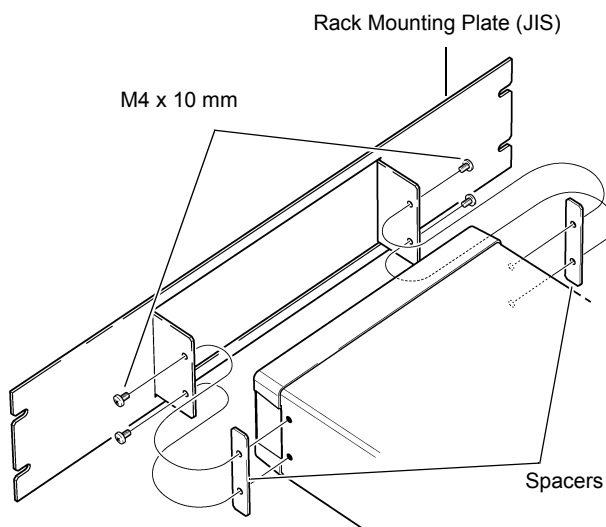

# Appendix10 Dimensional Diagram

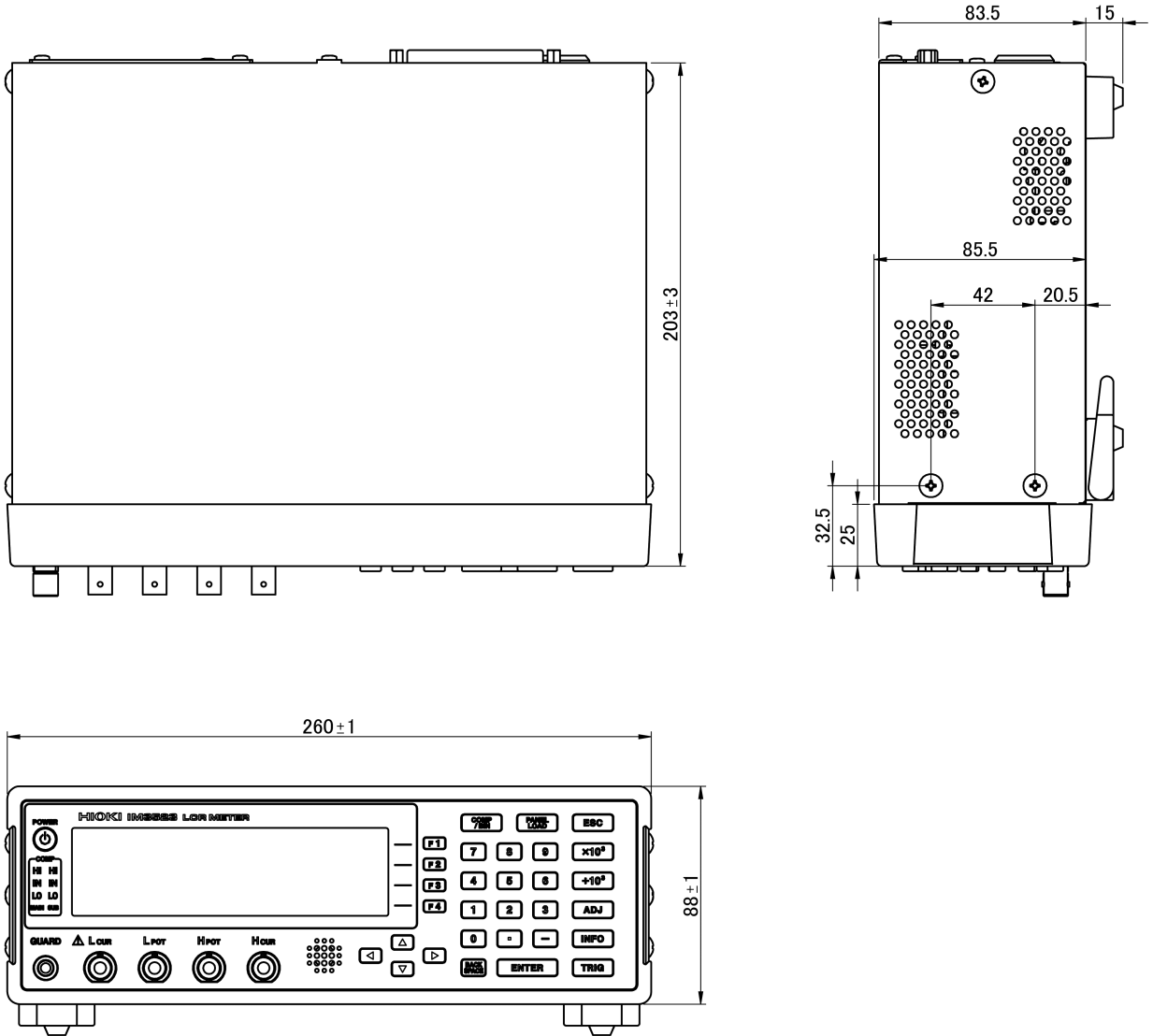

### Appendix11 Initial Settings Table

The following table shows the initial settings of the instrument.

Setting Items		Initial setting	Full instrument reset	*RST	:PRE-Set	Return to initial settings when power is turned on	Panel Save/load *1	
Measurement parameter		Z/θ	←	←	←	x	●	
LCR mode basic settings	Measurement frequency	1 kHz	←	←	←	x	●	
	Measurement signal level	Mode	V	←	←	←	x	●
		V	1.000 V	←	←	←	x	●
		CV	1.000 V	←	←	←	x	●
	Limit	CC	10.00 mA	←	←	←	x	●
		ON/OFF	OFF	←	←	←	x	●
		Current limit value	50.00 mA	←	←	←	x	●
	Measurement range	Voltage limit value	5.00 V	←	←	←	x	●
		Mode	AUTO	←	←	←	x	●
		AUTO range limit function (communications setting only)	100 mΩ/100 MΩ	←	←	←	x	●
		Range	100 Ω	←	←	←	x	●
Judgment synchronization setting	OFF	←	←	←	x	●		
Trigger mode	INT (Internal Trigger)	←	←	←	x	●		
AC range LIST settings *2	Measurement speed	MED	←	←	←	x	●	
	Number of times for average	1	←	←	←	x	●	
	Trigger delay	0.0000 s	←	←	←	x	●	
	Trigger synchronous output	ON/OFF	OFF	←	←	←	x	●
		Trigger time	0.0010 s	←	←	←	x	●
DC resistance measurement	Measurement range	Mode	AUTO	←	←	←	x	●
		AUTO range limit function (communications setting only)	100 mΩ/100 MΩ	←	←	←	x	●
		Range	100 Ω	←	←	←	x	●
		Judgment synchronization setting	OFF	←	←	←	x	●
	DC delay	0.0000 s	←	←	←	x	●	
	ADJ delay	0.0030 s	←	←	←	x	●	
	Line frequency	60 Hz	←	←	←	x	●	
DC range LIST settings *2	Measurement speed	MED	←	←	←	x	●	
	Number of times for average	1	←	←	←	x	●	

● :Available, x:Unavailable, ←:Same as default settings

\*1: ● (ADJ) also saved when TYPE is set to ALL.

\*2:All 10 ranges are initialized as shown to the right.

## Appendix11 Initial Settings Table

Setting Items		Initial setting	Full instrument reset	*RST	:PRE-Set	Return to initial settings when power is turned on	Panel Save/load *1	
Application settings	Measurement mode		LCR	←	←	←	×	●
	Judgment mode		OFF	←	←	←	×	●
	Memory	OFF/IN/ON	OFF	←	←	←	×	●
		Number of memory items	1000	←	←	←	×	●
	Waveform averaging function (communication setting only)	ON/OFF	OFF	←	←	←	×	●
		Waveform averaging count for each frequency band	Averaging count for MED	←	←	←	×	●
	Judgment result	Delay between judgment results and EOM	0.0000 s	←	←	←	×	×
		Reset	ON	←	←	←	×	×
	IO trigger	ENABLE	ON	←	←	←	×	×
		Edge	DOWN	←	←	←	×	×
	IO EOM	Mode	HOLD	←	←	←	×	×
		EOM output time	0.0050 s	←	←	←	×	×
	Contact check	Timing	OFF	←	←	←	×	●
		Threshold	2	←	←	←	×	●
	HIGH-Z Reject	ON/OFF	OFF	←	←	←	×	●
		Judgment standard	1000%	←	←	←	×	●
	Backlight	ON/OFF	ON	←	←	←	×	×
	Display digits		6/6	←	←	←	×	●
	Beep sound	Judgment result Key	ON	←	←	←	×	×
		Beep tone	A	←	←	←	×	×
Contrast		50	←	←	←	×	×	
Key-lock	OFF/FULL/SET	OFF	←	←	←	×	×	
	Passcode	3523	←	←	←	×	×	
Comparator	Mode		ABS/ABS	←	←	←	×	●
	Absolute value mode	Upper limit value	OFF/OFF	←	←	←	×	●
		Lower limit value	OFF/OFF	←	←	←	×	●
	Percent mode Deviation percentage mode	Reference value	1.00000 k/10.0000	←	←	←	×	●
		Upper limit value	OFF/OFF	←	←	←	×	●
Lower limit value		OFF/OFF	←	←	←	×	●	
BIN	Mode		ABS/ABS	←	←	←	×	●
	Absolute value mode	Upper limit value	OFF/OFF	←	←	←	×	●
		Lower limit value	OFF/OFF	←	←	←	×	●
	Percent mode Deviation percentage mode	Reference value	1.00000 k/10.0000	←	←	←	×	●
		Upper limit value	OFF/OFF	←	←	←	×	●
Lower limit value		OFF/OFF	←	←	←	×	●	
Continuous measurement	Display timing		REAL	←	←	←	×	×
Open circuit compensation	Compensation mode		OFF	←	←	No Change	×	● (ADJ)
	Correction value	G Correction	0.000 ns	←	←	No Change	×	● (ADJ)
		B Correction	0.000 ns	←	←	No Change	×	● (ADJ)
	Correction range limit function	DC	ON	←	←	No Change	×	● (ADJ)
		MIN	40.000 Hz	←	←	No Change	×	● (ADJ)
		MAX	200.00 kHz	←	←	No Change	×	● (ADJ)

● :Available, ×:Unavailable, ←:Same as default settings

\*1: ● (ADJ) also saved when TYPE is set to ALL.

\*2:All 10 ranges are initialized as shown to the right.

# A18

## Appendix11 Initial Settings Table

Setting Items		Initial setting	Full instrument reset	*RST	:PRE-Set	Return to initial settings when power is turned on	Panel Save/load *1	
Short circuit compensation	Compensation mode		OFF	←	←	No Change	×	● (ADJ)
	Correction value	R Correction value	0.00 mΩ	←	←	No Change	×	● (ADJ)
		X Correction value	0.00 mΩ	←	←	No Change	×	● (ADJ)
	Correction range limit function	DC	ON	←	←	No Change	×	● (ADJ)
		MIN	40.000 Hz	←	←	No Change	×	● (ADJ)
		MAX	200.00 kHz	←	←	No Change	×	● (ADJ)
Load correction value	ON/OFF		OFF	←	←	No Change	×	● (ADJ)
	Compensation mode		Z-θ	←	←	No Change	×	● (ADJ)
	Reference value	Z reference value	OFF	←	←	No Change	×	● (ADJ)
		θ reference value	OFF	←	←	No Change	×	● (ADJ)
	Compensation frequency		OFF	←	←	No Change	×	● (ADJ)
	Compensation signal level	Mode	V	←	←	No Change	×	● (ADJ)
		V	OFF	←	←	No Change	×	● (ADJ)
		CV	OFF	←	←	No Change	×	● (ADJ)
		CC	OFF	←	←	No Change	×	● (ADJ)
	Compensation range	Range	OFF	←	←	No Change	×	● (ADJ)
	Compensation value	Z coefficient	OFF	←	←	No Change	×	● (ADJ)
		θ coefficient	OFF	←	←	No Change	×	● (ADJ)
Cable length compensation		0 m	←	←	No Change	×	● (ADJ)	
Scaling compensation	ON/OFF		OFF	←	←	No Change	×	● (ADJ)
	Compensation value	A	1.000	←	←	No Change	×	● (ADJ)
		B	0.00000	←	←	No Change	×	● (ADJ)
Panel	Save type		ALL	←	←	No Change	×	×
	Panel		No registration	Clear all data	Clear all data	No Change	×	×

● :Available, ×:Unavailable, ← :Same as default settings

\*1: ● (ADJ) also saved when TYPE is set to ALL.

\*2:All 10 ranges are initialized as shown to the right.



## Appendix11 Initial Settings Table

Setting Items		Initial setting	Full instrument reset	*RST	:PRE-Set	Return to initial settings when power is turned on	Panel Save/load *1	
Interface	USB	Terminator	CR+LF	←	No Change	No Change	×	×
	GP-IB	Address	01	←	No Change	No Change	×	×
		Terminator	LF	←	No Change	No Change	×	×
	RS-232C	Baud rate	9600	←	No Change	No Change	×	×
		Handshake	OFF	←	No Change	No Change	×	×
		Terminator	CR+LF	←	No Change	No Change	×	×
	LAN	IP address	192.168.00 0.001	←	No Change	No Change	×	×
		Subnet mask	255.255.25 5.000	←	No Change	No Change	×	×
		Gateway	OFF	←	No Change	No Change	×	×
		Port	3500	←	No Change	No Change	×	×
		Terminator	CR+LF	←	No Change	No Change	×	×
	Printer	Baud rate	9600	←	No Change	No Change	×	×
		Handshake	OFF	←	No Change	No Change	×	×
		Mode	MANUAL	←	No Change	No Change	×	×
		Type	TEXT	←	No Change	No Change	×	×
	Header		OFF	←	←	No Change	●	×
	Status Byte register		0	No Change	No Change	No Change	●	×
	Event register		0	No Change	No Change	No Change	●	×
	Enable register		0	No Change	No Change	No Change	●	×
	:MEASure:ITEM		0,0	←	←	←	×	●
:MEASure:VALid		10	←	←	←	×	●	
Automatic output of measurement values		OFF	←	←	←	×	×	
Transfer format		ASCII	←	←	←	×	×	
Long format		OFF	←	←	←	×	×	

● : Available, × : Unavailable, ← : Same as default settings

\*1: ● (ADJ) also saved when TYPE is set to ALL.

\*2: All 10 ranges are initialized as shown to the right.

# Appendix12Device Compliance Statement

"Information on compliance to standards" based on the IEEE 488.2 standard

Item	Description
1. IEEE 488.1 interface functions	<b>See</b> Communication Instruction Manual (LCR Application Disk)
2. Operation with a device address other than 0 through 30	Such a setting is not possible.
3. Timing of changed device address recognition	A change of address is recognized immediately after changing.
4. Device settings at power on	The status information is cleared, and all other items are preserved. However, the header on/off setting, and response message separator and terminator are all reinitialized.
5. List of message exchange options	<ul style="list-style-type: none"> <li>• Input buffer capacity and operation</li> <li><b>See</b> Communication Instruction Manual (LCR Application Disk)</li> </ul> <p>Queries to which multiple response message units are returned</p> <pre> :BIN:FLIMit:ABSolute? ..... 2 :BIN:FLIMit:DEViation? ..... 2 :BIN:FLIMit:PERcent? ..... 2 :BIN:SLIMit:ABSolute? ..... 2 :BIN:SLIMit:DEViation? ..... 2 :BIN:SLIMit:PERcent? ..... 2 :COMParator:FLIMit:ABSolute? ..... 2 :COMParator:FLIMit:DEViation? ..... 3 :COMParator:FLIMit:PERcent? ..... 3 :COMParator:SLIMit:ABSolute? ..... 2 :COMParator:SLIMit:DEViation? ..... 3 :COMParator:SLIMit:PERcent? ..... 3 :CORRection:LIMit:POINT ..... 2 :CORRection:OPEN:DATA:ALL ..... * :CORRection:OPEN:DATA:SPOT ..... * :CORRection:SHORT:DATA:ALL ..... * :CORRection:SHORT:DATA:SPOT ..... * :CORRection:LOAD:CONDition? ..... 4 :CORRection:LOAD:DCResistance:CONDition? ..... 2 :CORRection:LOAD:REFerence? ..... 3 :CORRection:SCALE:DATA? ..... 2 :DCResistance:RANGE:AUTO:LIMit ..... 2 :MEASure? ..... * :MEASure:ITEM? ..... 2 :MONItor? ..... 4 :RANGE:AUTO:LIMit ..... 2                     </pre> <ul style="list-style-type: none"> <li>*The number of response messages varies depending on the settings.</li> <li>• Queries producing responses as syntax checking is performed: All queries produce responses when syntax checking is performed.</li> <li>• Whether any queries produce responses when read: There are no queries which produce response messages at the instant they are read in by the controller.</li> <li>• Whether any commands are coupled: There are no relevant commands.</li> </ul>

Item	Description
6. Summary of functional elements for use when constructing device specific commands, and whether compound commands or program headers can be used:	The followings can be used <ul style="list-style-type: none"> <li>• Program message</li> <li>• Program message terminator</li> <li>• Program message unit</li> <li>• Program message unit separator</li> <li>• Command message unit</li> <li>• Query message unit</li> <li>• Command program header</li> <li>• Query program header</li> <li>• Program data</li> <li>• Character program data</li> <li>• Decimal program data</li> <li>• Compound commands and program headers</li> </ul>
7. Buffer capacity limitations for block data	Block data is not used.
8. Summary of program data elements used in expressions, and deepest nesting level allowable in sub-expressions, including syntax restrictions imposed by the device.	Sub-expressions are not used. Character data and decimal data are the only program data elements used.
9. Response syntax for queries	<b>See</b> Communication Instruction Manual (LCR Application Disk)
10. Transmission congestion relating to device-to-device messages which do not conform to the general principles for basic response messages	There are no device to device messages.
11. Response capacity for block data	Block data does not appear in responses.
12. Summary of standard commands and queries used	<b>See</b> Communication Instruction Manual (LCR Application Disk)
13. Device state after a calibration query has been completed without any problem	The " <b>*CAL?</b> " query is not used.
14. "Existence/nonexistence of " <b>*DDT</b> " command	The " <b>*DDT</b> " query is not used.
15. Existence/nonexistence of macro command	Macros are not used.
16. For queries related to identification, explanation of the response to the " <b>*IDN?</b> " query	<b>See</b> Communications commands in the included LCR Application Disk documentation " <b>*IND</b> "
17. Capacity of the user data storage area reserved for when the " <b>*PUD</b> " command and the " <b>*PUD?</b> " query are being executed	The " <b>*PUD</b> " command and the " <b>*PUD?</b> " query are not used. Further, there is no user data storage area.
18. Resources when the " <b>*RDT</b> " command and the " <b>*RDT?</b> " query are being used	The " <b>*RDT</b> " command and the " <b>*RDT?</b> " query are not used. Further, there is no user data storage area.
19. "Conditions which are influenced when " <b>*RST</b> ", " <b>*LRN?</b> ", " <b>*RCL?</b> ", and " <b>*SAV</b> " are used	" <b>*LRN?</b> ", " <b>*RCL?</b> ", and " <b>*SAV</b> " are not used. The " <b>*RST</b> " command returns the instrument to its initial state.  <b>See</b> Communications commands in the included LCR Application Disk documentation " <b>*RST?</b> "
20. "Scope of the self-testing executed as a result of the " <b>*TST?</b> " query	<b>See</b> Communications commands in the included LCR Application Disk documentation " <b>*TST?</b> "
21. Additional organization of the status data used in a device status report	<b>See</b> Communication Instruction Manual (LCR Application Disk)
22. Whether commands are overlap or sequential type	All commands except <b>:MEASure?</b> , <b>:MEMory?</b> , <b>:CORRection:OPEN</b> , <b>:CORRection:SHORT</b> , and <b>:CORRection:LOAD</b> are sequence commands.
23. Criterion relating to the functions required at the instant that the termination message is produced, as a response to each command	Termination occurs when the command has been parsed.

# A22

## Appendix12 Device Compliance Statement

# Index

Absolute Value mode .....	78, 86
Accuracy .....	206
Adjustment Delay .....	69
All Compensation .....	127, 138
AUTO .....	43, 62
AUTO range limit function .....	44, 63
Average .....	54

## B

Beep Sound .....	110
BIN .....	83

## C

Cable Length Compensation .....	157
Calculation formula .....	A1
CC .....	37
Changing a Panel Name .....	167
Cleaning .....	215
Comparator .....	76
Configuring Settings for Continuous Measurement 121	
Connection Examples .....	190
Constant current .....	37
Constant voltage .....	37
Contact Check Function .....	103
Continuous Measurement Function .....	119
Countermeasures Against Incorporation of External Noise .....	A5
current limit .....	41
CV .....	37

## D

DC Bias .....	A7
DC Bias Current .....	A8
DC Bias Voltage .....	A7
DC delay .....	67, 69
Deleting a Panel .....	169
Deviation Percentage Mode .....	81
dgt. ....	4
Dimensional Diagram .....	A15
Display .....	107
Disposing .....	224

## E

EMI Suppression .....	A6
Error display .....	222
EXT I/O Connector (Instrument Side) .....	178
External Control .....	177
Q&A .....	192
External trigger .....	50

## F

f.s. ....	4
FAST .....	53, 73
frequency .....	33
Full Reset .....	221

## G

guarding .....	A4
----------------	----

## H

High Impedance Components .....	A3
HIGH-Z Reject .....	105
HOLD .....	43, 62

## I

I/O Test .....	176
In-circuit .....	A4
Initial Screen .....	12
Initial Settings Table .....	A16
Initializing .....	118, A16
Inspection, Repair .....	215
Instrument Installation .....	5
Interface .....	171
Internal Circuitry .....	188
Internal Trigger .....	50

## J

JUDGE SYNC setting .....	48
--------------------------	----

## L

LCD .....	124
LCD Display .....	107
LCR Application Disk .....	1, 205
LCR Function .....	29

---

---

Limit Value .....	41
Line Frequency .....	70
Load Compensation .....	145

**M**

---

Measurement accuracy .....	206
measurement cables .....	24
Measurement categories .....	4
Measurement frequency .....	33
Measurement Mode .....	13
Measurement Range .....	43, 62, 206
Measurement signal level .....	37
Measurement speed .....	53
Measurement Times .....	213
MED .....	53, 73
Memory function .....	97

**N**

---

Noise .....	A5
Number of Display Digits .....	108

**O**

---

Open Circuit Compensation .....	125, A11
Opening screen .....	22
opening screen .....	221
Options .....	2
output signal .....	176

**P**

---

Panel Load .....	165
Panel Save .....	162
Parallel Equivalent Circuit .....	A10
Parameter .....	31
Passcode .....	116
Percentage mode .....	79, 88
POWER button .....	26
power inlet .....	23
Power Line .....	A5
Pre-Operation Inspection .....	22
Printer .....	195
Printing .....	198

**R**

---

Rack Mounting .....	A13
Range .....	43, 62
rdg. ....	4
Replaceable Parts and Operating Lifetimes .....	215
Residual Charge Protection .....	A9
ROM/RAM Test .....	175

**S**

---

Saving Measurement Results .....	97
Scaling .....	158
Screen Contrast .....	113
Self Diagnosis .....	173
Series Equivalent Circuit Mode .....	A10
Setting the SYSTEM .....	171
Short Circuit Compensation .....	136, A11
signal level .....	37
Signal pin assignments .....	178
SLOW .....	53, 73
SLOW2 .....	53, 73
Specifications .....	201
Spot Compensation .....	131
Standby .....	26
System Reset .....	118

**T**

---

Timing Chart .....	184
EXT I/O .....	184
Trigger .....	50
trigger delay .....	56
Trigger Synchronous Output Function .....	57

**V**

---

V .....	37
Version .....	172
voltage limit .....	41

**W**

---

Waveform Averaging .....	99
--------------------------	----

---

# Warranty Certificate

# HIOKI

Model	Serial number	Warranty period Three (3) years from date of purchase ( ___ / ___ )
-------	---------------	--

Customer name: \_\_\_\_\_

Customer address: \_\_\_\_\_

### Important

- Please retain this warranty certificate. Duplicates cannot be reissued.
- Complete the certificate with the model number, serial number, and date of purchase, along with your name and address. The personal information you provide on this form will only be used to provide repair service and information about Hioki products and services.

This document certifies that the product has been inspected and verified to conform to Hioki's standards.

Please contact the place of purchase in the event of a malfunction and provide this document, in which case Hioki will repair or replace the product subject to the warranty terms described below.

### Warranty terms

1. The product is guaranteed to operate properly during the warranty period (three [3] years from the date of purchase).  
If the date of purchase is unknown, the warranty period is defined as three (3) years from the date (month and year) of manufacture (as indicated by the first four digits of the serial number in YYYY format).
2. If the product came with an AC adapter, the adapter is warranted for one (1) year from the date of purchase.
3. The accuracy of measured values and other data generated by the product is guaranteed as described in the product specifications.
4. In the event that the product or AC adapter malfunctions during its respective warranty period due to a defect of workmanship or materials, Hioki will repair or replace the product or AC adapter free of charge.
5. The following malfunctions and issues are not covered by the warranty and as such are not subject to free repair or replacement:
  - 1. Malfunctions or damage of consumables, parts with a defined service life, etc.
  - 2. Malfunctions or damage of connectors, cables, etc.
  - 3. Malfunctions or damage caused by shipment, dropping, relocation, etc., after purchase of the product
  - 4. Malfunctions or damage caused by inappropriate handling that violates information found in the instruction manual or on precautionary labeling on the product itself
  - 5. Malfunctions or damage caused by a failure to perform maintenance or inspections as required by law or recommended in the instruction manual
  - 6. Malfunctions or damage caused by fire, storms or flooding, earthquakes, lightning, power anomalies (involving voltage, frequency, etc.), war or unrest, contamination with radiation, or other acts of God
  - 7. Damage that is limited to the product's appearance (cosmetic blemishes, deformation of enclosure shape, fading of color, etc.)
  - 8. Other malfunctions or damage for which Hioki is not responsible
6. The warranty will be considered invalidated in the following circumstances, in which case Hioki will be unable to perform service such as repair or calibration:
  - 1. If the product has been repaired or modified by a company, entity, or individual other than Hioki
  - 2. If the product has been embedded in another piece of equipment for use in a special application (aerospace, nuclear power, medical use, vehicle control, etc.) without Hioki's having received prior notice
7. If you experience a loss caused by use of the product and Hioki determines that it is responsible for the underlying issue, Hioki will provide compensation in an amount not to exceed the purchase price, with the following exceptions:
  - 1. Secondary damage arising from damage to a measured device or component that was caused by use of the product
  - 2. Damage arising from measurement results provided by the product
  - 3. Damage to a device other than the product that was sustained when connecting the device to the product (including via network connections)
8. Hioki reserves the right to decline to perform repair, calibration, or other service for products for which a certain amount of time has passed since their manufacture, products whose parts have been discontinued, and products that cannot be repaired due to unforeseen circumstances.

**HIOKI E.E. CORPORATION**

<http://www.hioki.com>

18-07 EN-3







# HIOKI

<http://www.hioki.com>



**All regional  
contact  
information**

**HEADQUARTERS**

81 Koizumi  
Ueda, Nagano 386-1192 Japan

**HIOKI EUROPE GmbH**

Rudolf-Diesel-Strasse 5  
65760 Eschborn, Germany  
[hioki@hioki.eu](mailto:hioki@hioki.eu)

1906 EN

Edited and published by HIOKI E.E. CORPORATION

Printed in Japan

- CE declarations of conformity can be downloaded from our website.
- Contents subject to change without notice.
- This document contains copyrighted content.
- It is prohibited to copy, reproduce, or modify the content of this document without permission.
- Company names, product names, etc. mentioned in this document are trademarks or registered trademarks of their respective companies.